



Chelsea[®] Power Take-Off

2023 Applications Catalog



ENGINEERING YOUR SUCCESS.



WARNING — User Responsibility

FAILURE OR IMPROPER SELECTION OR IMPROPER USE OF THE PRODUCTS DESCRIBED HEREIN OR RELATED ITEMS CAN CAUSE DEATH, PERSONAL INJURY AND PROPERTY DAMAGE.

This document and other information from Parker Hannifin Corporation, its subsidiaries and authorized distributors provide product or system options for further investigation by users having technical expertise.

The user, through its own analysis and testing, is solely responsible for making the final selection of the system and components and assuring that all performance, endurance, maintenance, safety and warning requirements of the application are met. The user must analyze all aspects of the application, follow applicable industry standards, and follow the information concerning the product in the current product catalog and in any other materials provided from Parker or its subsidiaries or authorized distributors.

To the extent that Parker or its subsidiaries or authorized distributors provide component or system options based upon data or specifications provided by the user, the user is responsible for determining that such data and specifications are suitable and sufficient for all applications and reasonably foreseeable uses of the components or systems.

Offer of Sale

The items described in this document are hereby offered for sale by Parker Hannifin Corporation, its subsidiaries or its authorized distributors. This offer and its acceptance are governed by the provisions stated in the "Offer of Sale".



WARNING: This product can expose you to chemicals including Lead and Lead Compounds, and Di(2-ethylhexyl)phthalate (DEHP) which are known to the State of California to cause cancer and birth defects or other reproductive harm. For more information go to www.P65Warnings.ca.gov

© Copyright 2022, Parker Hannifin Corporation, All Rights Reserved

General Safety InformationPages 1.1 thru 1.11

Proper Matching of PTO	1.1
Rotating Auxiliary Driveshafts	1.2 thru 1.3
Pump Installation Precautions	1.4
How to Use the Catalog	1.5 thru 1.8
Power Take-Off Worksheet	1.9
Transmission Opening Chart	1.10
Input Gear Designators	1.11

**Section
1**

PTO Options & Kits Pages 2.1 thru 2.44

Mechanical 6-Bolt PTOs	2.1 thru 2.6	Constant Mesh 10-Bolt PTOs	2.24 thru 2.25
Mechanical 8-Bolt PTOs	2.7 thru 2.13	Split Shaft Gear Boxes	2.26
Mechanical Rear Mount	2.14	Crankshaft Driven	2.27 thru 2.28
PowerShift Hydraulic		Geared Adapters	2.29 thru 2.37
6-Bolt PTOs	2.15 thru 2.16	Kits	2.38 thru 2.41
PowerShift Pneumatic or Hydraulic		PTO Shift Options	2.42
6/8-Bolt PTOs	2.17 thru 2.19	Pumps	2.43
PowerShift 8-Bolt PTOs	2.20		
PowerShift Hydraulic 10-Bolt PTOs	2.21 thru 2.23		

**Section
2**

Flange DimensionsPages 3.1 thru 3.47

This section can be used for quick reference of flange dimensions.

**Section
3**

Assembly OptionsPages 4.1 thru 4.43

This section can be used for quick reference to PTO options or ordering units.

**Section
4**

ApplicationsPages 5.1.1 thru 5.16.36

This section contains the latest Transmission/PTO application information by Transmission Manufacturer.

**Section
5**

Offer of Sale Page 5.17.1 thru 5.17.3

GENERAL SAFETY INFORMATION

CHELSEA®
Parker
PART No. 328946X
SAFETY INFORMATION ENCLOSED
THESE LABELS MUST BE USED
READ OWNERS MANUAL

- APPLY THIS MASKING TAPE TO THE RAIL STICKER WHEN THE TRUCK IS BEING PAINTED.
- THIS MASKING TAPE MUST BE REMOVED BEFORE THE TRUCK HAS BEEN PAINTED.

CHELSEA®
Parker

DO NOT PAINT OVER THIS LABEL FOR MORE SAFETY

WARNING

ARE DANGEROUS TO SKIN, HAIR, HANDS, ETC. CAUSE SERIOUS INJURY OR DEATH



379274 A

MONTHLY: INSPECT...
IF NECESSARY...
SPECIFICATIONS...
IF APPLICABLE. PERFORM...
PARKER'S CHELSEA PRODUCTS DIVISION WILL NOT BE RESPONSIBLE FOR DAMAGE DUE TO THE OVERLOADING OF THIS EQUIPMENT. TO PERFORM PREVENTATIVE MAINTENANCE, DAMAGE TO THE EQUIPMENT DUE TO MISAPPLICATION, OR MISUSE, OR IMPROPER OPERATION OF THE EQUIPMENT AND ANCILLARY EQUIPMENT.
FAILURE TO COMPLY ENTIRELY WITH THE PROVISIONS SET FORTH IN THE OWNER'S MANUAL WILL RESULT IN VOIDING ALL WARRANTIES.

379915 D

Safety Guide
Selecting and Using Chelsea® Products and Related Accessories

Guide de sécurité
Sélection et utilisation des produits et accessoires connexes de Chelsea® Products

Guía de seguridad
Selección y uso de los productos Chelsea® y los accesorios relacionados

Safety Guide
Selecting and Using Chelsea® Products and Related Accessories

Guide de sécurité
Sélection et utilisation des produits et accessoires connexes de Chelsea® Products

Guía de seguridad
Selección y uso de los productos Chelsea® y los accesorios relacionados

Parker | Chelsea

ENGINEERING YOUR SUCCESS.

Contents

General Safety Information.....1.1 thru 1.11

 Proper Matching of PTO1.1

 Rotating Auxiliary Driveshafts1.2 thru 1.3

 Pump Installation Precautions1.4

 How to Use the Catalog1.5 thru 1.8

 Power Take-Off Worksheet.....1.9

 Transmission Opening Chart.....1.10

 Input Gear Designators.....1.11



These instructions are intended for the safety of the installer, operator, and supporting personnel. Read them carefully and make sure you understand them thoroughly.

To Prevent Injury to Yourself and/or Damage to the Equipment:

- Read carefully all owner's manuals, service manuals, and/or other instructions.
- Always follow proper procedures, and use proper tools and safety equipment.
- Be sure to receive proper training.
- Never work alone while under a vehicle or while repairing or maintaining equipment.
- Always use proper components in applications for which they are approved.
- Be sure to assemble components properly.
- Never use worn-out or damaged components.
- Always block any raised or moving device that may injure a person working on or under a vehicle.
- Never operate the controls of the Power Take-Off (PTO) or other driven equipment from any position that could result in getting caught in the moving machinery.

Proper Matching of PTO

 **WARNING:** A Power Take-Off must be properly matched to the vehicle transmission and to the auxiliary equipment being powered. An improperly matched Power Take-Off could cause severe damage to the vehicle transmission, the auxiliary driveshaft, and/or the auxiliary equipment being powered. **Damaged components or equipment could malfunction causing serious personal injury to the vehicle operator or to others nearby.**

To avoid personal injury and/or equipment damage:

- Always refer to Chelsea catalogs, literature, and owner's manuals and follow Chelsea recommendations when selecting, installing, repairing, or operating a Power Take-Off.
- Never attempt to use a Power Take-Off not specifically recommended by Chelsea for the vehicle transmission.
- Always match the Power Take-Offs specified output capabilities to the requirements of the equipment to be powered.
- Never use a Power Take-Off whose range of speed could exceed the maximum.

Cold Weather Operation of PowerShift PTOs

 **WARNING:** During extreme cold weather operation [32°F (0°C) and lower], a disengaged PowerShift Power Take-Off can momentarily transmit high torque that will cause unexpected output shaft rotation. This is caused by the high viscosity of the transmission oil when it is extremely cold. As slippage occurs between the Power Take-Off clutch plates, the oil will rapidly heat up and the viscous drag will quickly decrease.

The Power Take-Off output shaft rotation could cause unexpected movement of the driven equipment resulting in serious personal injury, death, or equipment damage.

To avoid personal injury and/or equipment damage:

- Driven equipment must have separate controls.
- The driven equipment must be left in the disengaged position when not in operation.
- Do not operate the driven equipment until the vehicle is allowed to warm up.

 This symbol warns of possible personal injury.

Rotating Auxiliary Driveshafts

WARNING: Rotating auxiliary driveshafts are dangerous. You can snag clothes, skin, hair, hands, etc. This can cause serious injury or death.

- Do not go under the vehicle when the engine is running.
- Do not work on or near an exposed shaft when the engine is running.
- Shut off the engine before working on the Power Take-Off or driven equipment.
- Exposed rotating driveshafts must be guarded.

Guarding Auxiliary Driveshafts

WARNING: We strongly recommend that a Power Take-Off and a directly mounted pump be used to eliminate the auxiliary driveshaft whenever possible. If an auxiliary driveshaft is used and remains exposed after installation, it is the responsibility of the vehicle designer and PTO installer to install a guard.

Using Set Screws

WARNING: Auxiliary driveshafts may be installed with either recessed or protruding set screws. If you choose a square head set screw, you should be aware that it will protrude above the hub of the yoke and may be a point where clothes, skin, hair, hands, etc. could be snagged. A socket head set screw, which may not protrude above the hub of the yoke, does not permit the same amount of torquing as does a square head set screw. Also a square head set screw, if used with a lock wire, will prevent loosening of the screw caused by vibration. Regardless of the choice made with respect to a set screw, an exposed rotating auxiliary driveshaft must be guarded.

Important: Safety Information and Owner's Manual

Chelsea Power Take-Offs are packaged with safety information decals, instructions, and an owner's manual. These items are located in the envelope with the PTO mounting gaskets. Also, safety information and installation instructions are packaged with some individual parts and kits. Be sure to read the owner's manual and safety information before installing or operating the PTO. Always install the safety information decals according to the instructions provided. Place the owner's manual in the vehicle glove compartment.

Operating the PTO with the Vehicle in Motion

WARNING: Some Power Take-Offs may be operated when the vehicle is in motion. To do so, the PTO must have been properly selected to operate at highway speeds and correctly matched to the vehicle transmission and the requirements of the driven equipment.

If in doubt about the PTOs specifications and capabilities, avoid operating the PTO when the vehicle is in motion. Improper application and/or operation can cause serious personal injury or premature failure of the vehicle, the driven equipment, and/or the PTO

Always remember to disengage the PTO when the driven equipment is not in operation.



This symbol warns of possible personal injury.

Chelsea PTO Safety Label Instructions

1. The two black and orange on white 5" x 7" pressure sensitive vinyl labels, part number 379274, must be placed on the vehicle frame rails (one (1) on each side), in a position that would be **HIGHLY** visible to anyone that would go under the truck near the PTO rotating shaft. If the vehicle is to be painted after these labels are installed, cover them with two (2) blank masking covers. Remove the masking covers after painting.
2. Place the one (1) black and orange on white 3.5" x 5" pressure sensitive vinyl label, part number 379275, on the visor nearest the operator of the vehicle, this must be placed near the PTO visor label.
3. Place the one (1) red and white with black lettering 3.5" x 7" pressure sensitive vinyl label, part number 379915, on the opposite side of the visor from the above label part number 379275.
4. Place the one (1) white and black heavy duty card, part number 379276, in the vehicle glove box in a position highly visible to the operator. For example, try to place this card on top of whatever may be in the glove box.

If you require labels, please order part number 328946X at no charge from your local Chelsea Warehouse or send request direct to:

Parker Hannifin Corporation
Chelsea Products Division
 8225 Hacks Cross Road
 Olive Branch, MS 38654
 Customer Service: (662) 895-1011

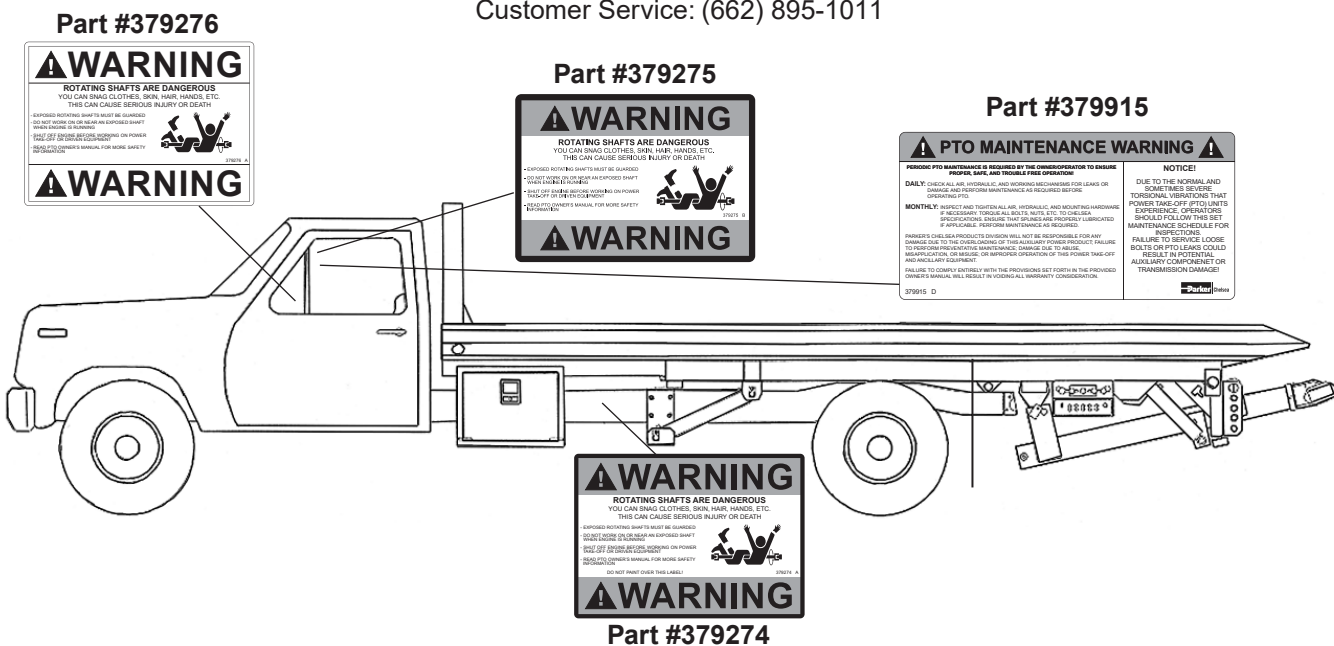

! This symbol warns of possible personal injury.

Pump Installation Precautions

Use a bracket to secure and support the pump to the transmission if:

- Do not go under the vehicle when the engine is running.
- The pump, fittings, hose assemblies, and oil weighs 40 pounds or more.
- The combined length of the PTO and pump is 18 inches or more, from the PTO centerline to the end of the pump.
- Extreme or unknown conditions of application such as, duty cycles, vehicle vibrations, engine harmonics, terrain, or driven equipment harmonics, are present.

ALSO: remember to pack the female pilot of the PTO pump shaft with grease before installing the pump on the PTO.

Use caution to ensure that the bracket does not pre-load or stress the pump/PTO bolts or installation hardware. Brackets must be designed and manufactured to adequately eliminate deflections from weight, vibration, and truck movements.

Please refer to the PTO Series' Owner's Manual for more information.

Power Take-Off Maintenance

Due to the normal and sometime severe torsional vibrations that Power Take-Off units experience, operators should follow a set maintenance schedule for inspections. Failure to service loose bolts or Power Take-Off leaks could result in potential auxiliary Power Take-Off or transmission damage.

Periodic PTO MAINTENANCE is required by the owner/operator to ensure proper, safe, and trouble free operation.

Daily: Check all air, hydraulic and working mechanisms before operating PTO.
Perform maintenance as required.

Monthly: Inspect for possible leaks and tighten all air, hydraulic, and mounting hardware, if necessary. Torque all bolts, nuts, etc. to Chelsea specifications. Ensure that splines are properly lubricated, if applicable. Perform maintenance as required.

With regards to the direct mounted pump splines, the PTO requires the application of a specially formulated anti-fretting, high pressure, high temperature grease. The addition of the grease has been proven to reduce the effects of the torsional vibrations, which result in fretting corrosion on the PTO internal splines as well as the pump external splines. Fretting corrosion appears as a "rusting and wearing" of the pump shaft splines. Severe duty applications, which require long PTO running times and high torque may require more frequent regreasing. Applications such as Utility Trucks that run continuously and are lightly loaded also require frequent regreasing due to the sheer hours of running time. It is important to note that service intervals will vary for each and every application and is the responsibility of the end user of the product. Chelsea also recommends that you consult your pump owner's manuals and technical services for their maintenance guidelines. Fretting corrosion is caused by many factors and without proper maintenance the anti-fretting grease can only reduce its effectiveness on components.

Chelsea offers the grease to our customers in two packages. The first is a 5/8 fluid ounce tube (379688), which is included with every applicable PTO, and the second is a 14-ounce grease cartridge (379831).

Warranty: Failure to comply entirely with the provisions set forth in the appropriate Owner's Manual will result in voiding of ALL Warranty consideration.

CHELSEA®

EATON FULLER

FLR-58

FOM-16D313E-LEP RTAO-10710C-AC RTAO-10710C-AS RTAO-12710C-AC RTAO-12710C-AS RTAO-14710C-AC RTAO-14710C-AS RTAO-16710C-AS	RTLC-16609E (Convertible 9 to 13 Speed) RTLO-12713A RTLO-13118-AMT RTLO-14713A RTLO-14713A-T2 RTLO-14718B RTLO-14718B-T2 RTLO-14918A-AS2	RTLO-14918A-AS3 RTLO-14918B RTLO-14918B-AS RTLO-16713A RTLO-16713A-T2 RTLO-16718B RTLO-16718B-T2 RTLO-16913A
---	---	---

BOTTOM SIDE ONLY	RIGHT SIDE ONLY
TRANSMISSION GEAR DATA: BOT 08-BOLT Opening Gear FORWARD of Centerline 47 Teeth - SPUR PITCH LINE TO APERTURE FACE: 0.8050" (20.4500MM)	TRANSMISSION GEAR DATA: R.S. 06-BOLT Opening Gear FORWARD of Centerline 45 Teeth - SPUR PITCH LINE TO APERTURE FACE: 1.0850" (27.5600MM)

CAUTION: Application Approval Required for PTO Output Shaft Speeds Above 2500 RPM

PTO Model	Torq l / C †	Dir Rot	Engine %		Filler Block	Adapter Assy	Stud Kit	PTO Model	Torq l / C †	Dir Rot	Engine %		Filler Block	Adapter Assy	Stud Kit
			Fwd	Rev							Fwd	Rev			

ONE SPEED - TWO GEAR - MECHANICAL SHIFT															
489XAAHX-*5 (11)	250 l	Opp	61				Furnished	221XCAHX-*3	250 l	Eng	66		7-A-032(P)(27)	329138X	Furnished
489XCAHX-*5 (12)	250 l	Opp	78				Furnished	221XEAHX-*3	250 l	Eng	76			329138X	Furnished
489XFAHX-*5 (2)	250 l	Opp	96				Furnished	221XPAHX-*3	200 l	Eng	124			329138X	Furnished
489XHAXH-*5 (14)	250 l	Opp	111				Furnished	442XAAHX-*3 (11)	250 l	Opp	58				Furnished
489XLAHX-*5 (1)	222 l	Opp	124				Furnished	442XBAHX-*3 (17)	250 l	Eng	58		REQUIRED		Furnished
489XQAHX-*5 (1)	206 l	Opp	134				Furnished	442XCAHX-*3 (12)	250 l	Opp	74				Furnished
489XRAHX-*5 (1)	178 l	Opp	155				Furnished	442XFAHX-*3 (2)	250 l	Opp	92				Furnished
489XSAHX-*5 (1)	150 l	Opp	184				Furnished	442XHAHX-*3 (14)	250 l	Opp	107				Furnished
680XFAHX-*3 (9)	288 l	Opp	96				Furnished	442XLAHX-*3 (1)	233 l	Opp	119				Furnished
680XHAHX-*3 (19)	249 l	Opp	111				Furnished	442XQAHX-*3 (1)	216 l	Opp	128				Furnished
680XQAHX-*3 (10)	206 l	Opp	134				Furnished	442XRAHX-*3 (1)	187 l	Opp	148				Furnished
680XRAHX-*3 (18)	178 l	Opp	155				Furnished	660XFAHX-*3 (9)	301 l	Opp	92				Furnished
680XSAHX-*3 (13)	150 l	Opp	184				Furnished	660XHAHX-*3 (19)	260 l	Opp	107				Furnished
823XBAHX-*3 (21)	423 l	Opp	65				Furnished	660XQAHX-*3 (10)	216 l	Opp	128				Furnished
823XDAHX-*3 (25)	357 l	Opp	77				Furnished	660XRAHX-*3 (18)	187 l	Opp	148				Furnished
823XGAHX-*3 (26)	329 l	Opp	84				Furnished								
823XJAHX-*3 (22)	279 l	Opp	99				Furnished								
823XMAHX-*3 (20)	238 l	Opp	116				Furnished								
823XRAHX-*3 (24)	172 l	Opp	160				Furnished								
823XTKX-*3 (16)	142 l	Opp	194		8-A-165(T)(27)		Furnished								
880XBAHX-*3 (3)	423 l	Opp	65				Furnished								
880XDAHX-*3 (4)	357 l	Opp	77				Furnished								
880XGAHX-*3 (8)	329 l	Opp	84				Furnished								
880XJAHX-*3 (5)	279 l	Opp	99				Furnished								
880XMAHX-*3 (6)	238 l	Opp	116				Furnished								
880XQAHX-*3 (15)	203 l	Opp	136				Furnished								
880XRAHX-*3 (7)	172 l	Opp	160				Furnished								

ONE SPEED - TWO GEAR POWERSHIFT (AIR OR HYDRAULIC)															
272XAAJX-*3	300 C	Opp	54			328481X	Furnished	272XAAJX-*3	300 C	Opp	51				Furnished
272XAAJX-*3	300 C	Opp	53			328481X	Furnished	272XBAJX-*3	300 C	Opp	62				Furnished
282XBAJX-*3	300 C	Opp	65				Furnished	272XCAJX-*3	300 C	Opp	76				Furnished

Continued on Next Page

† I = Intermittent Torque Only - De-Rate Torque Rating 30% for Continuous Duty.

C = Continuous or Intermittent Torque - No need to De-Rate Torque Rating.

IMPORTANT: Refer to the back of this transmission section and read all notes associated with this application page. Some notes may affect the proper PTO selection.

CAUTION: Eaton Transmission Division has established a Maximum Torque Limit for the Transmission PTO Driver Gear. For all RT/RTO/RTLO transmissions the torque limit is 350 Ft-lbs [475 N.m] unless the transmission has been upgraded to a roller type input shaft bearing, Eaton part number 4301417, then 750 Ft-lbs [1017 N.m] torque becomes the Maximum limit. All torque limits on this application page reflect the 350 Ft-lbs [475 N.m] limit at the Transmission PTO Drive Gear. Refer to the Chelsea PTO Torque Limit Chart in the front of this section for complete torque limit information.

CAUTION: Do not use geared adapters with 442 "A" and "C" ratios.

- (1) Input Gear Part No. 5-P-1004
- (2) Input Gear Part No. 5-P-1077
- (3) Input Gear Part No. 5-P-1100
- (4) Input Gear Part No. 5-P-1101
- (5) Input Gear Part No. 5-P-1102
- (6) Input Gear Part No. 5-P-1103

- (7) Input Gear Part No. 5-P-1104
- (8) Input Gear Part No. 5-P-1135
- (9) Input Gear Part No. 5-P-1242
- (10) Input Gear Part No. 5-P-1246
- (11) Input Gear Part No. 5-P-1280
- (12) Input Gear Part No. 5-P-1287

- (13) Input Gear Part No. 5-P-1322
- (14) Input Gear Part No. 5-P-1364
- (15) Input Gear Part No. 5-P-1385
- (16) Input Gear Part No. 5-P-1395
- (17) Input Gear Part No. 5-P-1418
- (18) Input Gear Part No. 5-P-1441

- (19) Input Gear Part No. 5-P-1494
- (20) Input Gear Part No. 5-P-283
- (21) Input Gear Part No. 5-P-285
- (22) Input Gear Part No. 5-P-325
- (24) Input Gear Part No. 5-P-721
- (25) Input Gear Part No. 5-P-971

- (26) Input Gear Part No. 5-P-980
- (27) Filler block furnished with PTO

1 Transmission Models

- Models that apply to this application page.

2 Transmission Gear Data

- Location of PTO opening on the transmission and opening size (SAE standard or non-standard).
- Gear position within the opening - either Gear to Rear of Centerline or Gear Forward of Centerline by 1/2 inch.



- Description of the PTO driver gear - tooth count of the gear and description of the cut of the gear teeth (Spur, Left Hand Helix, or Right Hand Helix).



SPUR - teeth are cut straight across from its face from the side



LH HELIX - teeth slant upwards from left to right



RH HELIX - teeth slant upwards from right to left

3 Pitch Line to Aperture Face

- The distance between the pitch line of the transmission PTO driver gear and the mounting face (aperture).

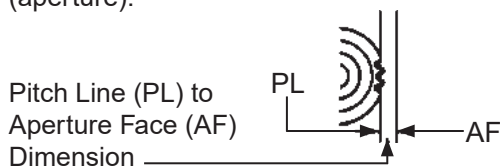

4 PTO Model

- The PTOs listed are normally mounted to the transmission with the output shaft toward the rear of the vehicle, with the shaft below the center of the opening.
- To complete the model number refer to the Assembly Options charts in section 4.

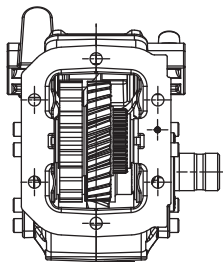

Ass'y 3

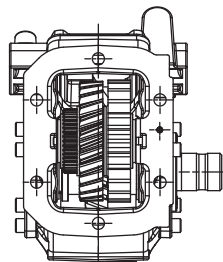

Ass'y 4

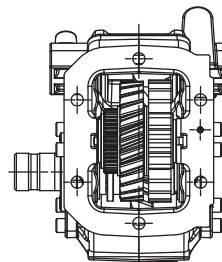

Ass'y 5

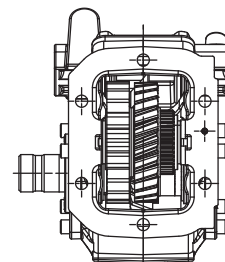

Ass'y 6

6 PTO Torque Ratings (shown in lbs-ft)

- Intermittent = Torque rating when the PTO operates only 5 minutes out of every 15. A PTO being used more than 5 minutes at a time is considered continuous duty and should have its torque rating reduced by 30%. To do this, multiply the given torque rating by .7. (i.e. 140 lbs-ft x .7 = 98 lbs-ft).
- Continuous = Some newer PTOs are designed with one torque rating for either Intermittent or Continuous operations. There is no need to de-rate the torque rating for PTOs that are rated as Continuous Duty.

6 PTO Direction of Rotation

- Viewed by standing at the rear of the vehicle, looking forward at the PTO shaft, with the PTO shaft pointing toward the rear of the vehicle.

PTO	Driven Equipment
OPP (looks “clockwise”)	Driven equipment must rotate counterclockwise (also called left-hand rotation, A for anti-clockwise or CCW for counterclockwise).
ENG (looks “counterclockwise”)	Driven equipment must rotate clockwise (also called right-hand rotation or C for clockwise).

- Remember that the PTO is specified looking from the rear of the truck to the front of the truck, and the driven equipment is specified looking from the front of the truck to the rear of the truck.

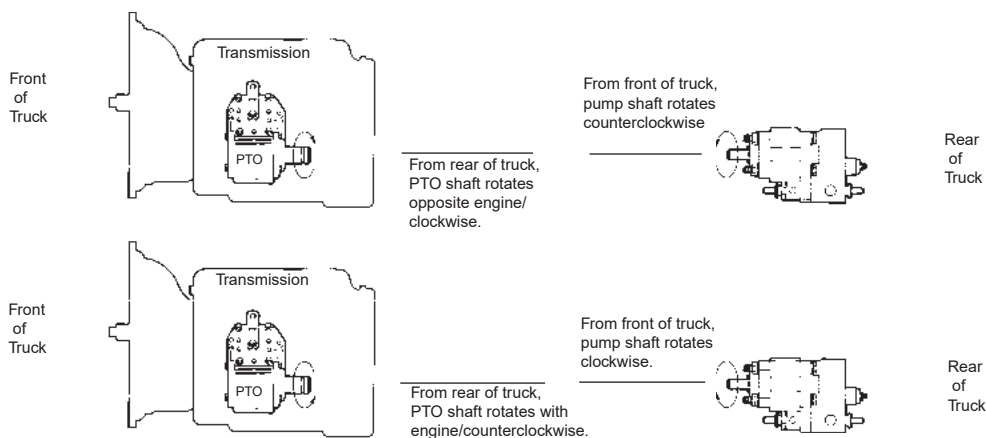

7 Output Shaft Speed Percentage

- The output shaft speed percentage is based upon engine RPM.
Ex: If the engine speed is 1000 RPM and the PTO rating is 90% of engine speed, the PTO output shaft will turn 900 RPM (1000 x .90). If the engine speed is 1000 RPM and the PTO rating is 127% of engine speed, the PTO output shaft will turn 1270 RPM (1000 x 1.27).

NOTE: Output shaft speeds should not exceed 2500 RPM without application approval from Chelsea.

8 Filler Block

- If a filler block is required to properly mount the PTO or an adapter, the correct part number will be shown here. It must be ordered separately from the PTO.
- If a (T) is shown next to the part number, the filler block should be positioned next to the transmission.
- If a (P) is shown next to the part number, the filler block should be positioned next to the Power Take-Off.

9 Adapter Assembly

- An adapter or adapter plate listed in this column is required to mount the PTO to the transmission and must be ordered separately.
- Geared Adapters - used to change the rotation of the output shaft, clear an interference problem, or reach a drive gear that may be deep within the transmission.
- Adapter Plates - used to mount a six-bolt PTO to an eight-bolt opening.
- A geared adapter should not be mounted to an adapter plate.
- Do not mount two or more geared adapters together.
- A geared adapter should not be used on automatic transmissions.

10 Stud Kit

- When the word *Furnished* appears in this column, the stud kit is included with the PTO.
- A stud kit number listed in this column (i.e. 7170-1X) means that the stud kit must be ordered separately from the PTO.

11 PTO Header

- PTO headers with type of shift mechanism. This describes the type of PTO listed in the section below the header.
- Mechanical = Gear into Gear Shifting
- PowerShift (Air), PowerShift (Hydraulic) = Clutch type

12 Torque Rating Duty Type

- Footnote explaining the PTO torque type relating to Intermittent and Continuous Duty. See arrow #5 on page 1.10.

13 Safety Notes

- Caution & Warning notes that pertain to the safe operation of the transmission and PTO. Each application section has notes relating to each specific application page that are important to the application of a PTO. All notes must be read prior to specifying a PTO.
- The notes section can be found in the back of each transmission section.

14 Numbered Footnotes

- These footnotes provide input gear numbers and filler block information by PTO model number.



Information from the Customer:

1. Make and model of transmission.

2. Type of driven equipment.

3. Input horsepower required of driven equipment.

4. Desired operating speed of driven equipment.

5. Approximate engine speed desired during operation.
Figure the equipment speed expressed as a percentage of the desired engine speed during the duty cycle.

Driven equipment ÷ Engine speed = PTO%

6. Direction of driven equipment shaft rotation in relation to direction of engine rotation (check one).

_____ Opposite Engine Rotation
_____ Engine Rotation
7. Type of connection between PTO and driven equipment (check one).

_____ Driveshaft
_____ Direct mount pump flange
_____ Pulleys and belts (requires eng. approval)
8. Mounting location (check all suitable locations).

_____ Left
_____ Right
_____ Bottom
_____ Top
_____ Countershaft
9. Duty cycle (check one).

_____ Intermittent
_____ Continuous (Greater than 5 mins in a 15 min period)
10. Other PTO speeds or reverse gear requirements.

Using the HY25-3000/US, Find:

11. Application page number for make and model of transmission.

12. From items 3 and 4 determine the intermittent torque requirements of the driven equipment using this formula:

 $(HP \times 5252) \div RPM = \text{lbs-ft}$

 $T = \text{_____ lbs-ft (intermittent)}$
13. If torque requirements are continuous (more than 5 minutes operation every 15 minutes) divide the torque figure by .7. The result will be the torque required for continuous operation.

14. Find the PTO in the HY25-3000/US catalog that meets the torque, rotation, and speed percentage requirements of the application. Note the PTO model number and all numbers for mounting parts on the lines below.

15. Determine what options are needed and change model number prefix and suffix to obtain correct options. (See Model Number Construction in section 4).

Safety

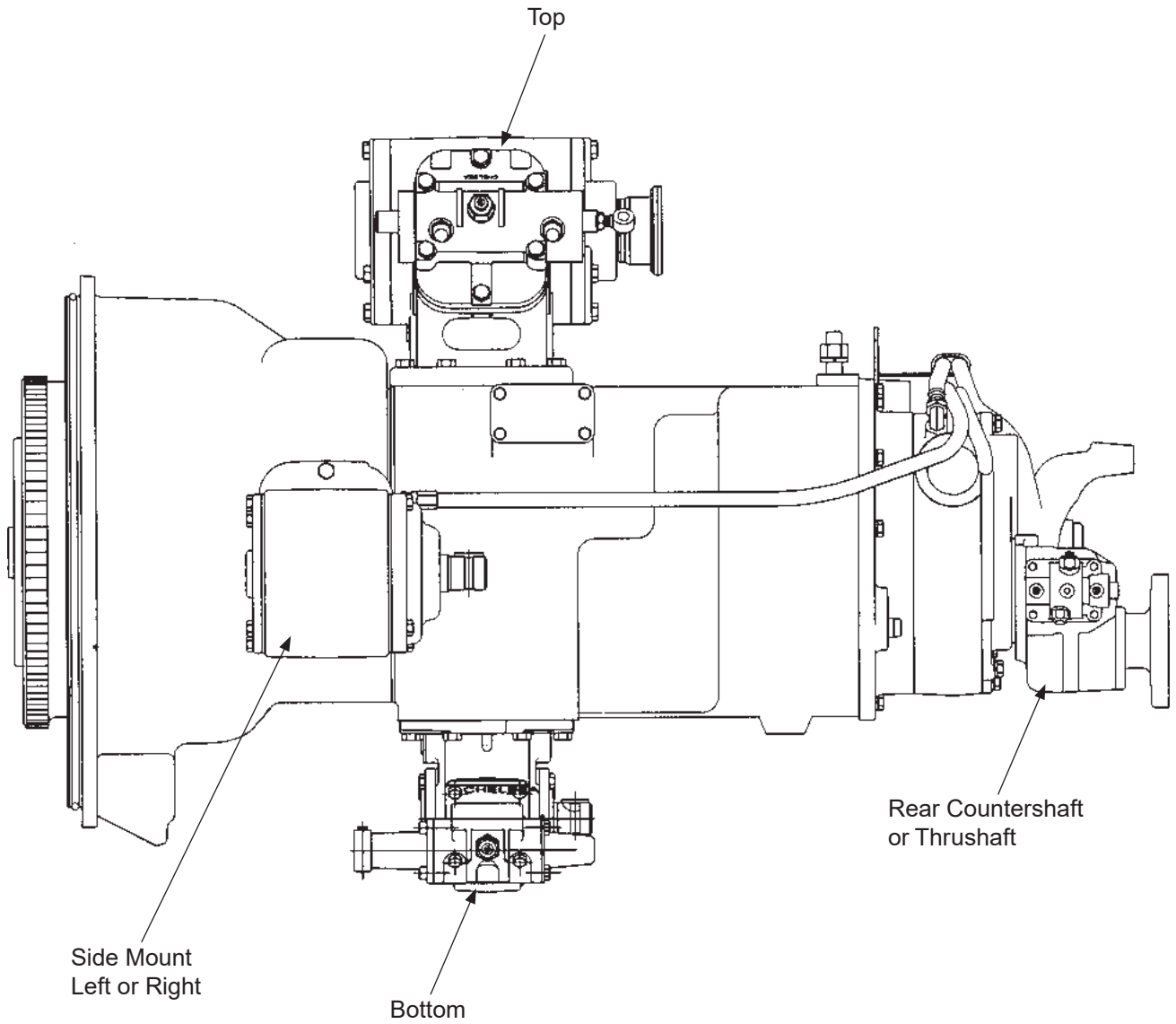

Input Gear Designators

AB	Universal	DS	Warner	HD	Mitsubishi	KV	Caterpillar
AC	Fiat	DU	Eaton Fuller	HD	Ford	KX	ZF
AD	Spicer	DX	Chevrolet	HE	Adapter Gear	KY	ZF
AG	Spicer	DY	Clark	HF	Adapter Gear	KZ	Isuzu
AH	Universal			HG	Adapter Gear		
AJ	Universal	EC	ZF	HH	Adapter Gear	LA	CAT
AK	Universal	ED	ZF	HJ	Adapter Gear	LB	ZF
AL	Eaton Fuller	EF	New Process	HK	Adapter Gear	LC	Eaton
AP	Spicer	EL	Isuzu	HL	Adapter Gear	LD	Eaton
AQ	Spicer	EP	Warner	HM	Adapter Gear	LE	Eaton
AR	Spicer	ER	Isuzu	HP	Adapter Gear	LG	Eaton
AU	Chelsea	ES	Eaton Fuller	HQ	Adapter Gear	LH	Eaton
AW	New Process	ET	Eaton Fuller	HR	Adapter Gear	LK	Eaton
AX	Eaton Fuller	EV	Eaton Fuller	HU	Mack	LL	Ford
		EW	Eaton Fuller	HV	Allison	LM	Eaton
BA	Navistar			HY	ZF	LP	Eaton
BC	Eaton Fuller	FA	Jatco/Isuzu	HZ	Eaton Fuller	LQ	Eaton
BE	Chevy	FB	GM/Chevy			LR	Eaton
BF	Warner	FC	Dodge	JB	Adapter Gear	LS	Mitsubishi
BG	Spicer	FE	Getrag	JD	Tremec	LT	Eaton
BH	Spicer	FJ	Allison	JE	Adapter Gear	LU	Eaton
BJ	Chevy	FL	ZF	JG	Mercedes	LV	Eaton
BK	New Process	FM	Nissan	JH	Mercedes	LX	Eaton
BL	New Process	FN	Spicer	JK	Eaton Fuller	LY	Eaton
BM	Eaton Fuller	FP	Mack/Renault	JL	Adapter Gear	LZ	Eaton
BN	New Process	FQ	Mack/Renault	JM	Eaton Fuller		
BP	Chevy/Spicer	FR	Eaton Fuller	JN	Adapter Gear	MA	Detroit
BQ	Chevy/Spicer	FS	Hino	JP	NVG	MB	Detroit
BR	Hino	FT	Mitsubishi	JQ	Adapter Gear	MC	Detroit
BS	New Process	FV	Isuzu	JR	Eaton Fuller	ME	Eaton
BU	Eaton Fuller	FW	Eaton Fuller	JS	Spicer	MF	Ford
BY	Warner	FZ	Hino	JT	Spicer	MG	ZF
BZ	Warner			JU	Spicer		
		GE	Eaton Fuller	JV	Eaton Fuller	QT	Allison
CB	New Process	GF	Eaton Fuller	JW	Eaton Fuller		
CC	New Process	GP	Eaton Fuller	JX	Adapter Gear		
CD	Warner	GQ	Tremec	JY	Adapter Gear		
CJ	Saab/Scania	GR	ZF	JZ	Adapter Gear		
CM	New Process	GS	ZF				
CR	Spicer	GW	Nissan	KA	Adapter Gear		
		GX	Mitsubishi	KB	Adapter Gear		
DA	Mack/Detroit	GX	Adapter Gear	KH	Mercedes		
DB	Eaton Fuller/ Detroit	GY	Adapter Gear	KJ	ZF		
		GZ	Adapter Gear	KK	Adapter Gear		
DC	Hino/Nissan	GZ	Eaton Fuller	KL	ZF		
DD	Spicer/Detroit			KM	Adapter Gear		
DH	Renault	HA	Adapter Gear	KN	TTC		
DJ	Renault	HA	Mitsubishi	KP	TTC		
DK	Renault	HB	Adapter Gear	KR	Adapter Gear		
DM	Eaton Fuller	HB	Mitsubishi	KS	Ford		
DN	Eaton Fuller	HC	Mitsubishi	KT	Universal		
DQ	Saab/Scania	HD	Adapter Gear	KU	Aisin		

NOTES

Safety



PTO OPTIONS & KITS

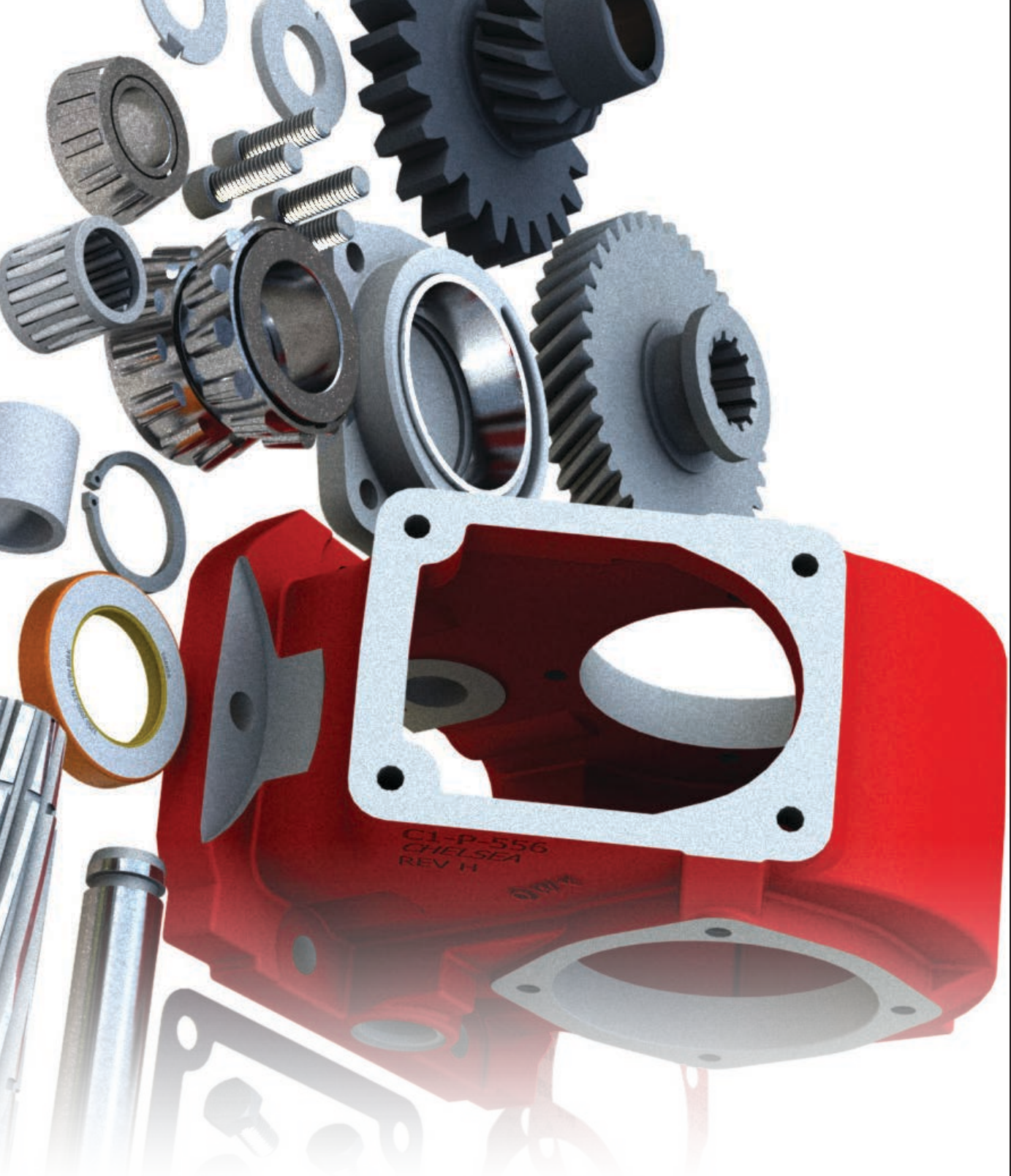

Mechanical Shift 6-Bolt PTOs

- PTO Options Chart2.1 thru 2.2
- Output Conversion Kits2.3 thru 2.4
- Shifter & Cover Kits2.5
- Installation Kits & Filler Blocks2.6

Mechanical Shift 8-Bolt PTOs

- PTO Options Chart2.7 thru 2.8
- Output Conversion Kits2.9 thru 2.11
- Shifter & Cover Kits2.12
- Filler Blocks & Adapter Plates2.13

Mechanical Shift Rear Mount PTOs

- PTO Options Chart2.14
- Installation Kits2.14

PowerShift Hydraulic 6-Bolt PTOs

- PTO Options Chart2.15
- Installation Kits2.16

PowerShift Pneumatic or Hydraulic 6/8-Bolt PTOs

- PTO Options Chart2.17
- Installation Kits2.18 thru 2.19

PowerShift Hydraulic 8-Bolt PTOs

- PTO Options Chart2.20

PowerShift Hydraulic 10-Bolt PTOs

- PTO Options Chart2.21 thru 2.22
- Installation & Conversion Kits2.23

Constant Mesh 10-Bolt PTOs

- PTO Options Chart2.24
- Output Conversion Kits2.25

Split Shaft Gear Boxes

- PTO Options Chart2.26
- Specification Charts2.26

Crankshaft Driven

- PTO Options Chart2.27
- Output Conversion Kits2.28

Continued on next page

Options

Contents

Geared Adapters

- Guide to Specifying Geared Adapters2.29
- Standard Geared Adapters2.30
- Specifying Standard Geared Adapters2.31 thru 2.32
- Kit-Style Dimensional Data2.33 thru 2.34
- Gear Charts2.35 thru 2.36
- Geared Adapters & Plates for Import Transmissions2.37

Kits

- Gasket Kits2.38
- Gasket & Seal Kits2.39
- PTO Options & Kits2.40
- Bracket Kits2.41

PTO Shift Options

- Shift Options Overview2.42

Pumps

- Dump Pump2.43

Options

PTO Options Chart – Mechanical PTOs		221	340
Lubrication			
P	Pressure Lube	X	
X	No Pressure Lube	X	X
Shifting			
A	Air Shift (Same Side as Output)		X
A	Air Shift	X	
C	Special Shift Control & Bracket Kit	X	
G	Air Shift (Opposite Output)		X
H	No Shift Assembly	X	
M	Constant Mesh	X	
P	12V Elec/Air Shift	X	
S	Air Shift w/ PTO/Dump Pump Combo Valve w/ Kick Out w/ Neutral Spring Return	X	
T	Air Shift w/ PTO/Dump Pump Combo Valve w/o Kick Out w/ Neutral Spring Return	X	
U	Air Shift w/ PTO/Dump Pump Combo Valve w/ Kick Out w/o Neutral Spring Return	X	
V	Air Shift w/o Installation Kit	X	X
W	Wire Shift	X	
X	Wire Shift w/o Cable & Knob	X	
Y	Lever Shift		X
Output			
AF	SAE B 2 or 4-Bolt Flange, SAE BB Shaft (1" - 15T)	X	
AK	SAE B 2-Bolt Flange, SAE B Shaft (7/8" - 13T)	X	
AZ	SAE B 4-Bolt Flange, SAE C Shaft (1-1/4" - 14T)	X	
GA	Greaseable SAE B 2-Bolt Rotatable Flange, SAE B Shaft (7/8" - 13T)	X	
GB	Greaseable SAE B 4-Bolt Rotatable Flange, SAE B Shaft (7/8" - 13T)	X	
GF	Greaseable SAE B 2 or 4-Bolt Flange, SAE BB Shaft (1" - 15T)	X	
GK	Greaseable SAE B 2 or 4-Bolt Flange, SAE B Shaft (7/8" - 13T)	X	
GQ**	Greaseable SAE B 2 or 4-Bolt Flange, SAE B Shaft (7/8" - 13T)	X	
GR	Greaseable Chelsea Special (Cloverleaf), SAE B Shaft (7/8" - 13T)	X	
RA	Rotatable SAE B 2-Bolt Flange, SAE B Shaft (7/8" - 13T)	X	
RB	Rotatable SAE B 4-Bolt Flange, SAE B Shaft (7/8" - 13T)	X	
RC	Rotatable SAE A 2-Bolt Flange, SAE A Shaft (5/8" - 9T)	X	
RD	Rotatable SAE A 2-Bolt Flange, SAE B Shaft (7/8" - 13T)	X	
RE	Rotatable SAE B 4-Bolt Flange, SAE BB Shaft (1" - 15T)	X	
RF	Rotatable SAE B 2-Bolt Flange, SAE BB Shaft (1" - 15T)	X	
RK	Rotatable SAE B 2 or 4-Bolt Flange, SAE B Shaft (7/8" - 13T)	X	
RY	Rotatable ISO 7653 Pump Mount DIN 5462 Shaft	X	
XD	Rd Standard Shaft (1-1/4" - 5/16" Key)	X	X
XE	SAE A 2 or 4-Bolt Flange, SAE A Shaft (5/8" - 9T)	X	
XK	SAE B 2 or 4-Bolt Flange, SAE B Shaft (7/8" - 13T)	X	
XQ**	SAE B 2 or 4-Bolt Flange, SAE B Shaft (7/8" - 13T)	X	
XR	Chelsea Special (Cloverleaf), SAE B Shaft (7/8" - 13T)	X	
XX***	1-1/4" Tapered Output Shaft w/Keyway	X	
XY	ISO 7653 Pump Mount DIN 5462 Shaft	X	

** XQ/GQ same as XK/GK except flange rotated 90°

*** Order companion (379824) separately

NOTE: Always check current price book for available options

PTO Options Chart – Mechanical PTOs		442	447	660
Lubrication				
P	Pressure Lube	X	X	X
X	No Pressure Lube	X	X	X
Shifting				
A	Air Shift	X	X	X
C	Special Shift Control & Bracket Kit	X	X	X
D	Eaton Procision™ 12V Elec/Air	X		
E	Hydraulic Shift (Eaton Procision™)	X		
H	No Shift Assembly	X	X	X
M	Constant Mesh	X	X	X
P	12V Elec/Air Shift	X	X	X
S	Air Shift w/ PTO/Dump Pump Combo Valve w/ Kick Out w/ Neutral Spring Return	X	X	X
T	Air Shift w/ PTO/Dump Pump Combo Valve w/o Kick Out w/ Neutral Spring Return	X	X	X
U	Air Shift w/ PTO/Dump Pump Combo Valve w/ Kick Out w/o Neutral Spring Return	X	X	X
V	Air Shift w/o Installation Kit	X	X	X
W	Wire Shift	X	X	X
X	Wire Shift less Cable & Knob	X	X	X
Output				
AF	SAE B 2 or 4-Bolt Flange, SAE BB Shaft (1" - 15T)	X	X	X
AK	SAE B 2-Bolt Flange, SAE B Shaft (7/8" - 13T)	X	X	X
AZ	SAE B 4-Bolt Flange, SAE C Shaft (1-1/4" - 14T)	X	X	X
GA	Greaseable SAE B 2-Bolt Rotatable Flange, SAE B Shaft (7/8" - 13T)	X	X	X
GB	Greaseable SAE B 4-Bolt Rotatable Flange, SAE B Shaft (7/8" - 13T)	X	X	X
GF	Greaseable SAE B 2 or 4-Bolt Flange, SAE BB Shaft (1" - 15T)	X	X	X
GH	Greaseable SAE B 2-Bolt Rotatable Flange, SAE BB Shaft (1" - 15T)			X
GK	Greaseable SAE B 2 or 4-Bolt Flange, SAE B Shaft (7/8" - 13T)	X	X	X
GQ**	Greaseable SAE B 2 or 4-Bolt Flange, SAE B Shaft (7/8" - 13T)	X	X	X
GR	Greaseable Chelsea Special (Cloverleaf), SAE B Shaft (7/8" - 13T)	X	X	X
GY	Greaseable ISO 7653 Pump Mount DIN 5462 Shaft			X
GZ	Greaseable SAE B 2 or 4-Bolt Flange, SAE C Shaft (1-1/4" - 14T)			X
RA	Rotatable SAE B 2-Bolt Flange, SAE B Shaft (7/8" - 13T)	X	X	X
RB	Rotatable SAE B 4-Bolt Flange, SAE B Shaft (7/8" - 13T)	X	X	X
RC	Rotatable SAE A 2-Bolt Flange, SAE A Shaft (5/8" - 9T)	X	X	X
RD	Rotatable SAE A 2-Bolt Flange, SAE B Shaft (7/8" - 13T)	X	X	X
RE	Rotatable SAE B 4-Bolt Flange, SAE BB Shaft (1" - 15T)	X	X	X
RF	Rotatable SAE B 2-Bolt Flange, SAE BB Shaft (1" - 15T)	X	X	X
RJ	Rotatable SAE B 2 or 4-Bolt Flange, SAE BB Shaft (1" - 15T)			X
RK	Rotatable SAE B 2 or 4-Bolt Flange, SAE B Shaft (7/8" - 13T)	X	X	X
RY	Rotatable ISO 7653 Pump Mount DIN 5462 Shaft	X	X	X
SQ	SAE B 4-Bolt Flange, SAE B Shaft (7/8" - 13T)	X		
XD	Rd Standard Shaft (1-1/4" - 5/16" Key)	X	X	X
XE	SAE A 2 or 4-Bolt Flange, SAE A Shaft (5/8" - 9T)	X	X	X
XK	SAE B 2 or 4-Bolt Flange, SAE B Shaft (7/8" - 13T)	X	X	X
XQ**	SAE B 2 or 4-Bolt Flange, SAE B Shaft (7/8" - 13T)	X	X	X
XR	Chelsea Special (Cloverleaf), SAE B Shaft (7/8" - 13T)	X	X	X
XV	1410 Series Companion Flange			X
XX***	1-1/4" Tapered Output Shaft w/ Keyway	X	X	X
XY	ISO 7653 Pump Mount DIN 5462 Shaft	X	X	X

** XQ/GQ same as XK/GK except flange rotated 90°

*** Order companion (379824) separately

NOTE: Always check current price book for available options

For converting the 221, 290, 442, 447, 660 Series Chelsea PTOs from a driveshaft output, or as listed, to a new pump flange output, use the following kits. Consult the Chelsea price book for availability by series.

Pump Suffix	Kit Number Suffix	Kit Number	Flange Type	Shaft Type (SAE)
AF	XD to AF	328591-30X	SAE B 2 or 4-Bolt	1" - 15 Tooth Splined (BB)
AF (Wet Spline 221)	XD to AF	328591-140X	SAE B 2 or 4-Bolt	1" - 15 Tooth Splined (BB)
AK	XD to AK	328591-28X	SAE B 2-Bolt	7/8" - 13 Tooth Splined (B)
AK (B Ratio)	XD to AK	329436-7X	SAE B 2-Bolt	7/8" - 13 Tooth Splined (B)
AZ	XD to AZ	328591-70X	SAE B 2 or 4-Bolt	1-1/4" - 14 Tooth Splined (C)
SQ	XD to SQ	328591-149X	SAE B 4-Bolt	7/8" - 13 Tooth Splined (B)
SQ (B Ratio)	XD to SQ	329436-9X	SAE B 4-Bolt	7/8" - 13 Tooth Splined (B)
XE	XD to XE	328591-27X	SAE A 2 or 4-Bolt	5/8" - 9 Tooth Splined (A)
XK	XD to XK	328591-16X	SAE B 2 or 4-Bolt	7/8" - 13 Tooth Splined (B)
XK (B Ratio)	XD to XK	329436-3X	SAE B 2 or 4-Bolt	7/8" - 13 Tooth Splined (B)
XQ	XD to XQ	328591-17X	SAE B 2 or 4-Bolt	7/8" - 13 Tooth Splined (B)
XQ (B Ratio)	XD to XQ	329436-6X	SAE B 2 or 4-Bolt	7/8" - 13 Tooth Splined (B)
XR	XD to XR	328591-52X	Chelsea Special (Cloverleaf)	7/8" - 13 Tooth Splined (B)
XV	XD to XV	328591-130X	1410 Series Companion Flange	1-1/4" Output Shaft w/ Keyway
XX	XD to XX	328591-122X	Not Included	1-1/4" Tapered Output Shaft w/ Keyway
XY	XD to XY	328591-121X	Not Included	DIN 5462 (B8x32x36 - 8T)
RC (Rotatable)	XD to RC	328591-112X	SAE A 2-Bolt	5/8" - 9 Tooth Splined (A)
RD (Rotatable)	XD to RD	328591-113X	SAE A 2-Bolt	7/8" - 13 Tooth Splined (B)
RD (B Ratio) (Rotatable)	XD to RD	329436-8X	SAE A 2-Bolt	7/8" - 13 Tooth Splined (B)
RA (Rotatable)	XD to RA XR to RA	328591-55X 328591-53X	SAE B 2-Bolt SAE B 2-Bolt	7/8" - 13 Tooth Splined (B) 7/8" - 13 Tooth Splined (B)
RA (B Ratio) (Rotatable)	XD to RA	329436-1X	SAE B 2-Bolt	7/8" - 13 Tooth Splined (B)
RF (Rotatable)	XD to RF	328591-78X	SAE B 2-Bolt	1" - 15 Tooth Splined (BB)
RB (Rotatable)	XD to RB XR to RB	328591-56X 328591-54X	SAE B 4-Bolt SAE B 4-Bolt	7/8" - 13 Tooth Splined (B) 7/8" - 13 Tooth Splined (B)
RB (B Ratio) (Rotatable)	XD to RB	329436-2X	SAE B 4-Bolt	7/8" - 13 Tooth Splined (B)
RE (Rotatable)	XD to RE	328591-134X	SAE B 4-Bolt	1" - 15 Tooth Splined (BB)
RK (Rotatable)	XD to RK (WS) XD to RK (DS)	328591-160X 328591-159X	SAE B 2 or 4-Bolt Rotatable	7/8" - 13 Tooth Splined (B)
RY (Rotatable)	XD to RY	328591-131X	ISO 7653 Pump Mount	DIN 5462 (B8x32x36 - 8T)
GA (Greaseable)	XD to GA XR to GA RA to GA	328591-72X 328591-73X 328591-106X	SAE B 2-Bolt Rotatable	*7/8" - 13 Tooth Splined (B)
GA (660 Series) (Greaseable)	XD to GA RA to GA	328591-124X 328591-109X	SAE B 2-Bolt	*7/8" - 13 Tooth Splined (B)
GH (Greaseable)	XD to GH RF to GH	328591-116X 328591-114X	SAE B 2-Bolt Rotatable	*1" - 15 Tooth Splined (BB)
GH (660 Series) (Greaseable)	XD to GH RF to GH	328591-117X 328591-115X	SAE B 2-Bolt Rotatable	*1" - 15 Tooth Splined (BB)
GB (Greaseable)	XD to GB XR to GB RB to GB	328591-74X 328591-75X 328591-107X	SAE B 4-Bolt Rotatable	*7/8" - 13 Tooth Splined (B)
GB (660 Series) (Greaseable)	XD to GB RG to GB	328591-125X 328591-110X	SAE B 4-Bolt	*7/8" - 13 Tooth Splined (B)
GK (Greaseable)	XD to GK XK to GK	328591-89X 328591-86X	SAE B 2 or 4-Bolt	*7/8" - 13 Tooth Splined (B)
GK (660 Series) (Greaseable)	XD to GK XK to GK	328591-99X 328591-96X	SAE B 2 or 4-Bolt	*7/8" - 13 Tooth Splined (B)
GQ (Greaseable)	XD to GQ XQ to GQ	328591-91X 328591-86X	SAE B 2 or 4-Bolt	*7/8" - 13 Tooth Splined (B)
GQ (660 Series) (Greaseable)	XD to GQ XQ to GQ	328591-101X 328591-96X	SAE B 2 or 4-Bolt	*7/8" - 13 Tooth Splined (B)

*Grease fitting on end of shaft

Continued on Next Page

Options

For converting the 660 Series Chelsea PTOs from a driveshaft output, or as listed, to a new pump flange output, use the following kits. Consult the Chelsea price book for availability by series.

Pump Suffix	Kit Number Suffix	Kit Number	Flange Type	Shaft Type (SAE)
GF (Greaseable)	XD to GF AF to GF	328591-71X 328591-108X	SAE B 2 or 4-Bolt	*1" - 15 Tooth Splined (BB)
GF (660 Series) (Greaseable)	XD to GF AF to GF	328591-123X 328591-111X	SAE B 2 or 4-Bolt	*1" - 15 Tooth Splined (BB)
GZ (Greaseable)	XD to GZ AZ to GZ	328591-93X 328591-88X	SAE B 2 or 4-Bolt	*1-1/4" - 14 Tooth Splined (C)
GZ (660 Series) (Greaseable)	XD to GZ AZ to GZ	328591-103X 328591-98X	SAE B 2 or 4-Bolt	*1-1/4" - 14 Tooth Splined (C)
GR (Greaseable)	XD to GR	328591-76X	Chelsea Special (Cloverleaf)	*7/8" - 13 Tooth Splined (B)
GR (660 Series) (Greaseable)	XD to GR	328591-126X	Chelsea Special (Cloverleaf)	*7/8" - 13 Tooth Splined (B)
GY (Greaseable)	XD to GY XY to GY	328591-92X 328591-87X	ISO 7653 Pump Mount	*DIN 5462 (B8x32x36 - 8T)
GY (660 Series) (Greaseable)	XD to GY XY to GY	328591-102X 328591-97X	ISO 7653 Pump Mount	*DIN 5462 (B8x32x36 - 8T)

*Grease fitting on end of shaft

PTO Shift Mechanisms Field Conversion Kits					
Series/ Application	Assembly Arrangement	Wire to Air	Lever to Air	Wire to Elec. Over Air	Lever to Elec. Over Air
221	3, 4, 5 & 6	328390-88X	N/A	328390-109X (12V)	N/A
340	4 & 5	N/A	328390-92X	N/A	N/A
442	3, 4, 5 & 6	328390-117X	328390-117X	328390-119X (12V) 328390-120X (24V)	328390-119X (12V) 328390-120X (24V)
447	3, 4, 5 & 6	N/A	328390-117X	328390-127X (12V)	N/A
660	3, 4, 5 & 6	328390-117X	328390-117X	328390-119X (12V) 328390-120X (24V)	N/A

N/A – Non Applicable

6-Bolt Cover Assemblies			
Series/ Application	Assembly Arrangement	Wire Control	Air Control
221	3 & 6	328805-1X	328723X
221	4 & 5	328805-2X	328723X
340	G4 & A5	N/A	328911X
	A4 & G5		328912X
442 Q, W & X	3 & 6	329119-1X	329361X
442 Q, W & X	4 & 5	329119-2X	
442 F, L, R, S & U	3 & 6	329121-1X	
442 F, L, R, S & U	4 & 5	329121-2X	
442 A, B & C	3 & 6	329271-1X	
442 A, B & C	4 & 5	329271-2X	
442 (All Ratios)	All		
447 Q & W	3 & 6	329151-1X	
447 Q & W	4 & 5	329151-2X	
447 S, U & R	3 & 6	329152-1X	
447 S, U & R	4 & 5	329152-2X	
447 (All Ratios)	All		
660 Q & W	3 & 6	329119-1X	
660 Q & W	4 & 5	329119-2X	
660 F, S & U	3 & 6	329121-1X	
660 F, S & U	4 & 5	329121-2X	
660 (All Ratios)	All		

Installation Kits							
Series/ Application	Assembly Arrangement	Wire Control	Air Control	Electric Over Air		Air Shift w/ Combo Valve Less Kick Out	Air Shift w/Combo Valve
				12 Volt	24 Volt		
221	3, 4, 5 & 6	328380X	328388-98X	328388-47X	328388-48X	N/A	328388-65X
340	A & G Shift	N/A	328388-40X	N/A	N/A	N/A	N/A
442	3, 4, 5 & 6	328380X	328388-98X	328388-47X	328388-48X	328388-72X	328388-65X
447	3, 4, 5 & 6	328380X	328388-98X	328388-47X	328388-48X	N/A	328388-65X
660	3, 4, 5 & 6	328380X	328388-98X	328388-47X	328388-48X	328388-72X	328388-65X

N/A – Non Applicable

Filler Blocks

A filler block, or spacer, may be required on certain transmissions to properly space the PTO and get the correct backlash. The application page will call out the filler block as required.

Two filler blocks may be used in combination with one or more gaskets between the filler block surfaces to obtain the proper spacing.

In computing the total thickness of the filler block and gasket combination, use a factor of .012" (compressed thickness of a .020" gasket 35-P-9-2 or 35-P-15-2) for every .020" gasket required in the installation.

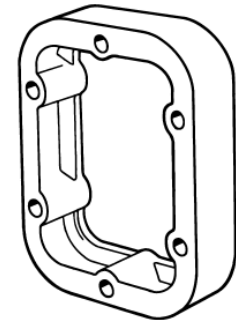

6-Bolt Filler Blocks

Part Number	A Thickness	Material	Part Number	A Thickness	Material
7-A-032	.032"	Fiber	7-A-500	.500"	Cast Iron
7-A-062	.062"	Fiber	7-A-500	.500"	Cast Iron
7-A-093	.093"	Steel	7-A-550	.550"	Cast Iron
7-A-125	.125"	Steel	7-A-562	.562"	Cast Iron
7-A-140	.140"	Steel	7-A-700	.700"	Cast Iron
7-A-165	.165"	Steel	7-A-800	.800"	Cast Iron
7-A-187	.187"	Steel	7-A-1000	1.000"	Cast Iron
7-A-200	.200"	Cast Iron	7-A-1180	1.180"	Cast Iron
7-A-240	.240"	Cast Iron	7-A-1250	1.250"	Cast Iron
7-A-270	.270"	Cast Iron	7-A-1468	1.468"	Cast Iron
7-A-300	.300"	Cast Iron	7-A-1520	1.520"	Cast Iron
7-A-350	.350"	Cast Iron	7-A-1640	1.640"	Cast Iron
7-A-400	.400"	Cast Iron	7-A-1875	1.875"	Cast Iron
7-A-450	.450"	Cast Iron	7-A-2000	2.000"	Cast Iron

PTO Options Chart – Mechanical PTOs		348	489	680	823	863	880
Lubrication							
P	Pressure Lube		x	x	x	x	x
W	Wet Spline				x		
X	No Pressure Lube	x	x, DT12	x, DT12	x, DT12	x	x, DT12
Shifting							
A	Air Shift		x	x	x, DT12		x, DT12
A	Air Shift (Same Side as Output)	x					
C	Special Shift Control & Bracket Kit		x	x			
D	12V Elec/Air Shift Eaton Endurant™		x	x			x
G	Air Shift (Opposite Output)	x					
H	No Shift Assembly		x	x			x
M	Constant Mesh		x, DT12	x, DT12	x		x, DT12
P	12V Elec/Air Shift		x	x	x, DT12		x, DT12
Q	24V Elec/Air Shift		x	x			
S	Air Shift w/ PTO/Dump Pump Combo Valve w/ Kick Out w/ Neutral Spring Return		x	x			
T	Air Shift w/ PTO/Dump Pump Combo Valve w/o Kick Out w/ Neutral Spring Return		x	x			
U	Air Shift w/ PTO/Dump Pump Combo Valve w/ Kick Out w/o Neutral Spring Return		x	x			
V	Air Shift w/o Installation Kit	x	x	x	x, DT12		x, DT12
W	Wire Shift		x	x			
X	Wire Shift w/o Cable & Knob		x	x			
Y	Lever Shift	x			x	x	x
5	Double Acting Air Shift w/o Installation Kit		DT12	DT12			
6	Double Acting (DA) Shift for Endurant XD			x			
Output							
AB	DIN 120				x, DT12		
AC	DIN 100				x, DT12		
AF	SAE B 2 or 4-Bolt Flange, SAE BB Shaft (1" - 15T)		x	x			x, DT12
AK	SAE B 2-Bolt Flange, SAE B Shaft (7/8" - 13T)		x	x			
AZ	SAE B 2 or 4-Bolt Flange, SAE C Shaft (1-1/4" - 14T)						x, DT12
AZ	SAE B 4-Bolt Flange, SAE C Shaft (1-1/4" - 14T)		x	x			
GA	Greaseable SAE B 2-Bolt Rotatable Flange, SAE B Shaft (7/8" - 13T)		x	x			
GB	Greaseable SAE B 4-Bolt Rotatable Flange, SAE B Shaft (7/8" - 13T)		x	x			
GF	Greaseable SAE B 2 or 4-Bolt Flange, SAE BB Shaft (1" - 15T)		x	x			
GH	Greaseable SAE B 2-Bolt Rotatable Flange, SAE BB Shaft (1" - 15T)			x			
GK	Greaseable SAE B 2 or 4-Bolt Flange, SAE B Shaft (7/8" - 13T)		x	x			
GQ**	Greaseable SAE B 2 or 4-Bolt Flange, SAE B Shaft (7/8" - 13T)		x	x			
GR	Greaseable Chelsea Special (Cloverleaf), SAE B Shaft (7/8" - 13T)		x	x			
GS	Greaseable SAE C 2 or 4-Bolt Flange, SAE C Shaft (1-1/4" - 14T)				x, DT12		x, DT12
GU	Greaseable SAE C 2-Bolt Flange, SAE C Shaft (1-1/4" - 14T)				x, DT12		
GY	Greaseable ISO 7653 Pump Mount DIN 5462 Shaft			x			
GZ	Greaseable SAE B 2 or 4-Bolt Flange, SAE C Shaft (1-1/4" - 14T)			x			
RA	Rotatable SAE B 2-Bolt Flange, SAE B Shaft (7/8" - 13T)		x	x			
RB	Rotatable SAE B 4-Bolt Flange, SAE B Shaft (7/8" - 13T)		x	x			
RC	Rotatable SAE A 2-Bolt Flange, SAE A Shaft (5/8" - 9T)		x	x			
RD	Rotatable SAE A 2-Bolt Flange, SAE B Shaft (7/8" - 13T)		x	x			
RE	Rotatable SAE B 4-Bolt Flange, SAE BB Shaft (1" - 15T)		x	x			
RF	Rotatable SAE B 2-Bolt Flange, SAE BB Shaft (1" - 15T)		x	x			
RJ	Rotatable SAE B 2 or 4-Bolt Flange, SAE BB Shaft (1" - 15T)		x				
RK	Rotatable SAE B 2 or 4-Bolt Flange, SAE B Shaft (7/8" - 13T)		x, DT12	x, DT12			
RY	Rotatable ISO 7653 Pump Mount DIN 5462 Shaft		x	x			

Options

** XQ/GQ same as XK/GK except flange rotated 90°

Continued on Next Page

w = Wet Spline Option

DT12 = Detroit DT12™

NOTE: Always check current price book for available options

PTO Options Chart – Mechanical PTOs	348	489	680	823	863	880
-------------------------------------	-----	-----	-----	-----	-----	-----

Options

Output (Cont'd)							
SQ	SAE B 4-Bolt Flange, SAE B Shaft (7/8" - 13T)		x				
XD	Rd Standard Shaft (1-1/4" - 5/16" Key)	x	x, DT12	x, DT12			
XE	SAE A 2 or 4-Bolt Flange, SAE A Shaft (5/8" - 9T)		x	x			
XK	SAE B 2 or 4-Bolt Flange, SAE B Shaft (7/8" - 13T)		x	x			x, DT12
XQ**	SAE B 2 or 4-Bolt Flange, SAE B Shaft (7/8" - 13T)		x	x			
XR	Chelsea Special (Cloverleaf), SAE B Shaft (7/8" - 13T)		x	x			
XS	SAE C 2 or 4-Bolt Flange, SAE C Shaft (1-1/4" - 14T)						x, DT12
XS	SAE C 4-Bolt Flange, SAE C Shaft (1-1/4" - 14T)				x, w, DT12		
XU	SAE C 2-Bolt Flange, SAE C Shaft (1-1/4" - 14T)				x, w, DT12		
XV	1410 Series Companion Flange		DT12	x, DT12	x, DT12	x	x, DT12
XX***	1-1/4" Tapered Output Shaft w/ Keyway		x	x			
XY	ISO 7653 Pump Mount DIN 5462 Shaft		x, DT12	x, DT12			x, DT12
Self-Lube							
LG	1410 Series Companion Flange w/ Self Lube						x
LA	SAE B 2-Bolt w/Self Lube Pump, SAE B Shaft (7/8" - 13T)		x	x			
LB	SAE A 2-Bolt w/Self Lube Pump, SAE B Shaft (7/8" - 13T)		x	x			

** XQ/GQ same as XK/GK except flange rotated 90°

*** Order companion (379824) separately

w = Wet Spline Option

DT12 = Detroit DT12™

NOTE: Always check current price book for available options

For converting 8-Bolt Chelsea PTOs from a driveshaft output to a pump flange output, use the following kits.

489 Series

Pump Suffix	Kit Number Suffix	Kit Number	Flange Type	Shaft Type (SAE)
AF	XD to AF	328591-30X	SAE B 2 or 4-Bolt	1" - 15 Tooth Splined (BB)
AK	XD to AK	328591-28X	SAE B 2-Bolt	7/8" - 13 Tooth Splined (B)
AZ	XD to AZ	328591-70X	SAE B 2 or 4-Bolt	1-1/4" - 14 Tooth Splined (C)
SQ	XD to SQ	328591-149X	SAE B 4-Bolt	7/8" - 13 Tooth Splined (B)
XE	XD to XE	328591-27X	SAE A 2 or 4-Bolt	5/8" - 9 Tooth Splined (A)
XK	XD to XK	328591-16X	SAE B 2 or 4-Bolt	7/8" - 13 Tooth Splined (B)
XK (B Ratio)		329436-3X		
XQ	XD to XQ	328591-17X	SAE B 2 or 4-Bolt	7/8" - 13 Tooth Splined (B)
XQ (B Ratio)		329436-6X		
XR	XD to XR	328591-52X	Chelsea Special (Cloverleaf)	7/8" - 13 Tooth Splined (B)
XX	XD to XX	328591-122X	Not Included	1-1/4" Tapered Output Shaft w/ Keyway
XY	XD to XY	328591-121X	ISO 7653 Pump Mount	DIN 5462 (B8x32x36 - 8T)
RC (Rotatable)	XD to RC	328591-112X	SAE A 2-Bolt	5/8" - 9 Tooth Splined (A)
RD (Rotatable)	XD to RD	328591-113X	SAE A 2-Bolt	7/8" - 13 Tooth Splined (B)
RD (B Ratio)	XD to RD	329436-8X	SAE A 2-Bolt	7/8" - 13 Tooth Splined (B)
RA (Rotatable)	XD to RA	328591-55X	SAE B 2-Bolt	7/8" - 13 Tooth Internal Spline (B)
	XR to RA	328591-53X		
RA (B Ratio)	XD to RA	329436-1X	SAE B 2-Bolt	7/8" - 13 Tooth Internal Spline (B)
RF (Rotatable)	XD to RF	328591-78X	SAE B 2-Bolt	1" - 15 Tooth Splined (BB)
RB (Rotatable)	XD to RB	328591-56X	SAE B 4-Bolt	7/8" - 13 Tooth Internal Spline (B)
	XR to RB	328591-54X		
RB (B Ratio)	XD to RB	329436-2X	SAE B 4-Bolt	7/8" - 13 Tooth Internal Spline (B)
RE (Rotatable)	XD to RE	328591-134X	SAE B 4-Bolt	1" - 15 Tooth Splined (BB)
RK (Wet Spline)	XD to RK	328591-160X	SAE B 2 or 4-Bolt Rotatable	7/8" - 13 Tooth Splined (B)
RK (Dry Spline)	XD to RK	328591-159X	SAE B 2 or 4-Bolt Rotatable	7/8" - 13 Tooth Splined (B)
RY (Rotatable)	XD to RY	328591-131X	ISO 7653 Pump Mount	DIN 5462 (B8x32x36 - 8T)
GA (Greaseable)	XD to GA	328591-72X	SAE B 2-Bolt Rotatable	*7/8" - 13 Tooth Internal Spline (B)
	XR to GA	328591-73X		
	RA to GA	328591-106X		
GB (Greaseable)	XD to GB	328591-74X	SAE B 4-Bolt Rotatable	*7/8" - 13 Tooth Internal Spline (B)
	XR to GB	328591-75X		
	RB to GB	328591-107X		
GK (Greaseable)	XD to GK	328591-89X	SAE B 2 or 4-Bolt	*7/8" - 13 Tooth Internal Spline (B)
	XK to GK	328591-86X		
GQ (Greaseable)	XD to GQ	328591-91X	SAE B 2 or 4-Bolt	*7/8" - 13 Tooth Internal Spline (B)
	XQ to GQ	328591-86X		
GF (Greaseable)	XD to GF	328591-71X	SAE B 2 or 4-Bolt	*1" - 15 Tooth Internal Spline (BB)
	AF to GF	328591-108X		
GR (Greaseable)	XD to GR	328591-76X	Chelsea Special (Cloverleaf)	*7/8" - 13 Tooth Internal Spline (B)

*Grease fitting on end of shaft

NOTE: Use 329097-1X to convert PTOs with AK, XP, XQ, XN, or XK output to the self-lube pump option.

NOTE: Contact Chelsea Customer Service for kits not listed.

680 Series

Pump Suffix	Kit Number Suffix	Kit Number	Flange Type	Shaft Type (SAE)
AF	XD to AF	328591-30X	SAE B 2 or 4-Bolt	1" - 15 Tooth Internal Spline (BB)
AK	XD to AK	328591-28X	SAE B 2-Bolt	7/8" - 13 Tooth Internal Spline (B)
AZ	XD to AZ	328591-70X	SAE B 2 or 4-Bolt	1-1/4" - 14 Tooth Internal Spline (C)
XE	XD to XE	328591-27X	SAE A 2 or 4-Bolt	5/8" - 9 Tooth Internal Spline (A)
XK	XD to XK	328591-16X	SAE B 2 or 4-Bolt	7/8" - 13 Tooth Internal Spline (B)
XQ	XD to XQ	328591-17X	SAE B 2 or 4-Bolt	7/8" - 13 Tooth Internal Spline (B)
XQ (B Ratio)	XD to XQ	329436-6X		
XR	XD to XR	328591-52X	Chelsea Special (Cloverleaf)	7/8" - 13 Tooth Internal Spline (B)
XV	XD to XV	328591-130X	1410 Series Companion Flange	1-1/4" Output Shaft w/ Keyway
XX	XD to XX	328591-122X	Not Included	1-1/4" Tapered Output Shaft w/ Keyway
XY	XD to XY	328591-121X	ISO 7653 Pump Mount	DIN 5462 (B8x32x36 - 8T)
RC (Rotatable)	XD to RC	328591-112X	SAE A 2-Bolt	5/8" - 9 Tooth Internal Spline (A)
RA (Rotatable)	XD to RA	328591-55X	SAE B 2-Bolt	7/8" - 13 Tooth Internal Spline (B)
	XR to RA	328591-53X		
RA (B Ratio)	XD to RA	329436-1X	SAE B 2-Bolt	7/8" - 13 Tooth Internal Spline (B)
RB (Rotatable)	XD to RB	328591-56X	SAE B 4-Bolt	7/8" - 13 Tooth Internal Spline (B)
	XR to RB	328591-54X		
RB (B Ratio)	XD to RB	329436-2X	SAE B 4-Bolt	7/8" - 13 Tooth Internal Spline (B)
RE (Rotatable)	XD to RE	328591-134X	SAE B 4-Bolt	1" - 15 Tooth Internal Splined (BB)
RK (Rotatable)	XD to RK	328591-159X	SAE B 2 or 4-Bolt Rotatable	7/8" - 13 Tooth Splined (B)
	XD to RK	328591-160X		
RY (Rotatable)	XD to RY	328591-131X	ISO 7653 Pump Mount	DIN 5462 (B8x32x36 - 8T)
GA (Greaseable)	XD to GA	328591-124X	SAE B 2-Bolt Rotatable	*7/8" - 13 Tooth Internal Spline (B)
	RA to GA	328591-109X		
GH (Greaseable)	XD to GH	328591-117X	SAE B 2-Bolt Rotatable	*1" - 15 Tooth Internal Spline (BB)
	RF to GH	328591-115X		
GB (Greaseable)	XD to GB	328591-125X	SAE B 4-Bolt Rotatable	*7/8" - 13 Tooth Internal Spline (B)
	RB to GB	328591-110X		
GK (Greaseable)	XD to GK	328591-99X	SAE B 2 or 4-Bolt	*7/8" - 13 Tooth Internal Spline (B)
	XK to GK	328591-96X		
GQ (Greaseable)	XD to GQ	328591-101X	SAE B 2 or 4-Bolt	*7/8" - 13 Tooth Internal Spline (B)
	XQ to GQ	328591-96X		
GF (Greaseable)	XD to GF	328591-123X	SAE B 2 or 4-Bolt	*1" - 15 Tooth Internal Spline (BB)
	AF to GF	328591-111X		
GZ (Greaseable)	XD to GZ	328591-103X	SAE B 2 or 4-Bolt	*1-1/4" - 14 Tooth Internal Spline (C)
	AZ to GZ	328591-98X		
GR (Greaseable)	XD to GR	328591-126X	Chelsea Special (Cloverleaf)	*7/8" - 13 Tooth Internal Spline

*Grease fitting on end of shaft

NOTE: Contact Chelsea Customer Service for kits not listed.

823 Series

Pump Suffix	Kit Number Suffix	Kit Number	Flange Type	Shaft Type (SAE)
GS (Greaseable)	XS to GS XV to GS	328591-136X 328591-137X	SAE C 2 or 4-Bolt Flange	1-1/4" - 14 Tooth Spline

880 Series

Pump Suffix	Kit Number Suffix	Kit Number	Flange Type	Shaft Type (SAE)
AZ (Splash Lube)	XV to AZ	328591-127X	SAE B 2 & 4-Bolt	1-1/4" - 14 Tooth Internal Spline
AZ (Pressure Lube)	AV to AZ	328591-128X		
XK (Splash Lube)	XV to XK	328591-32X	SAE B 2 & 4-Bolt	7/8" - 13 Tooth Internal Spline
XK (Pressure Lube)	XV to XK	328591-58X		
XS (Splash Lube)	XV to XS	328591-31X	SAE C 2 & 4-Bolt	1-1/4" - 14 Tooth Internal Spline
XS (Pressure Lube)	XV to XS	328591-49X		
XY	XV to XY	328591-34X	ISO 7653 Pump Mount	DIN 5462 (B8x32x36 - 8T)
GS (Greaseable)	XS to GS XV to GS	328591-133X 328591-135X	SAE C 2 & 4-Bolt	1-1/4" - 14 Tooth Internal Spline

PTO Shift Mechanisms Field Conversion Kits					
Series	Assembly Arrangement	Wire to Air	Lever to Air	Wire to Elec. Over Air	
				12 Volt	24 Volt
348	A & G Shift		328390-92X		
489	3, 4, 5 & 6	328390-117X	328390-117X	328390-119X	328390-120X
680	3, 4, 5 & 6	328390-117X	328390-117X	328390-119X	328390-120X
823	3, 4, 5 & 6		328390-154X		

Cover Assemblies				
Series/ Application	Assembly Arrangement	Wire Control	Lever Control	Air Control
489 Q, W & X	3 & 6	329119-1X	No Longer Available	
489 Q, W, & X	4 & 5	329119-2X	No Longer Available	
489 F,L,R,S & U	3 & 6	329121-1X	No Longer Available	
489 F,L,R,S & U	4 & 5	329121-2X	No Longer Available	
489 A & C	3 & 6	329271-1X	No Longer Available	
489 A & C	4 & 5	329271-2X	No Longer Available	
489 (All Ratios)	All		No Longer Available	329361X
680 Q & W	3 & 6	329119-1X	No Longer Available	
680 Q & W	4 & 5	329119-2X	No Longer Available	
680 F, S & U	3 & 6	329121-1X	No Longer Available	
680 F, S & U	4 & 5	329121-2X	No Longer Available	
680 (All Ratios)	All		No Longer Available	329361X
880	3, 4, 5 & 6		329125X	329126X

Installation Kits							
Series/ Application	Assembly Arrangement	Wire Control	Air Control	Electric Over Air		Air Shift w/ Combo Valve PTO Kick Out	Air Shift w/ Valve Combo
				12 Volt	24 Volt		
489	3, 4, 5 & 6	*328380X	328388-98X	328388-47X	328388-48X	328388-72X	328388-65X
680	3, 4, 5 & 6	*328380X	328388-98X	328388-47X	328388-48X	328388-72X	328388-65X
823			328388-61X				
880			329216-3X				

* Control Cable & Knob not Included

Filler Blocks

A filler block, or spacer, may be required on certain transmissions to properly space the PTO and get the correct backlash. The application page will call out the filler block as required.

Two filler blocks may be used in combination with one or more gaskets between the filler block surfaces to obtain the proper spacing.

In computing the total thickness of the filler block and gasket combination, use the factor given in the chart below for each gasket being used.

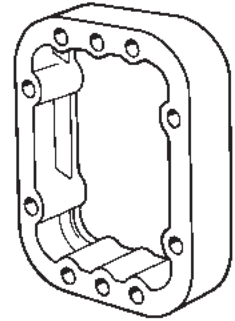

8-Bolt Gaskets		
Part Number	Nominal Thickness	Crushed Thickness (Factor)
35-P-9-1	.010"	.006"
35-P-9-2	.020"	.012"
35-P-15-1	.010"	.006"
35-P-15-2	.020"	.012"

8-Bolt Filler Blocks					
Part Number	A Thickness	Material	Part Number	A Thickness	Material
8-A-032	.032"	Fiber	8-A-295	.295"	Cast Iron
8-A-093	.093"	Steel	8-A-375	.375"	Cast Iron
8-A-062	.062"	Fiber or Steel	8-A-500	.500"	Cast Iron
8-A-165	.165"	Steel	8-A-600	.600"	Cast Iron
8-A-190	.190"	Steel	8-A-700	.700"	Cast Iron
8-A-248	.248"	Steel or Cast Iron			

8-Bolt Adapter Plates

8-Bolt adapter plates are used to convert an SAE 8-Bolt aperture or a non Standard opening to an SAE 6-Bolt aperture.

Adapter Plates			
Adapter Kit Number	A Thickness or Angularity	Adapter Plate Part Number	Stud Kit Number
310778X	.375"	26-P-22	328170-127X
328787X	.460"	26-P-27	328170-129X
328564X	.460"	26-P-27	328170-127X
328481X	.248"	328453X	328170-128X

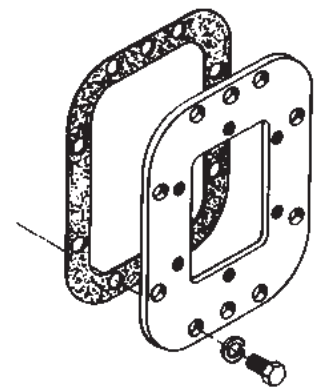

Options

PTO Options Chart – Rear Mount PTOs		511	524	541
Input Gear Designator				
AA	ZF	X	X	
AC	ZF-AS Tronic Meritor Freedomline™	X	X	
AH	ZF	X	X	
AQ	ZF	X	X	
AS	Volvo I-Shift/Mack mDrive	X	X	
AU	Fuller			X
BD	Fuller			X
DA	Detroit DT12™		X	
DB	Detroit DT12™		X	
DD	Detroit DT12™		X	
LZ	Eaton Endurant™	X	X	
ME	Eaton Endurant™ XD (18 Speed)		X	
Lubrication				
X	Non Wet Spline	X	X	
W	Wet Spline	X		
Shifting				
A	Air Shift	X	X	X
D	Eaton Endurant™	X	X	
F	12V Elec/Air ZF-AS Tronic Meritor Freedomline™	X	X	
H	No Shift Kit	X	X	
P	12V Elec/Air Shift	X	X	
Q	24V Elec/Air Shift	X	X	
V	Volvo I-Shift/Mack mDrive Kit	X	X	
Y	Lever Shift			X
Output				
XK	SAE B 2 or 4-Bolt Flange, SAE B Shaft (7/8" - 13T)	X	X	X
XV	1410 Series Companion Flange	X	X, W	X
XY	ISO 7653 Pump Mount DIN 5462 Shaft	X, W	X, W	

w = Wet Spline Option

DT12 = Detroit DT12™

NOTE: Always check current price book for available options

Installation Kits					
Series/ Application	Air Shift	Electric Over Air		Volvo I-Shift Mack mDrive	Electric Over Air (ZF-AS Tronic) 12 Volt
		12 Volt	24 Volt		
511	328388-98X	328388-47X	328388-48X	329809X	N/A
524	328388-98X	328388-47X	328388-48X	329809X	328388-82X
541	328388-61X	N/A	N/A	N/A	N/A

N/A – Non Applicable

PTO Options Chart – PowerShift PTOs		249	249V	252
Lubrication				
P	Pressure Lube			X
X	No Pressure Lube	X	X	X
Shifting				
B	12V Elec/Hyd	X	X	X
E	Less Wiring Harness	X	X	
K	12V Elec/Hyd w/ EOC	X	X	
Output				
08	Hyd. Pump 10.8 GPM @1200 Eng. RPM	X		
09	Hyd. Pump 12.6 GPM @1200 Eng. RPM	X		
11	Hyd. Pump 14.4 GPM @1200 Eng. RPM	X		
15	Hyd. Pump 17.0 GPM @1200 Eng. RPM	X		
16	Hyd. Pump 2.1 GPM @1200 Eng. RPM	X		
26	Hyd. Pump 3.5 GPM @1200 Eng. RPM	X		
32	Hyd. Pump 4.2 GPM @1200 Eng. RPM	X		
37	Hyd. Pump 4.9 GPM @1200 Eng. RPM	X		
42	Hyd. Pump 5.7 GPM @1200 Eng. RPM	X		
55	Hyd. Pump 7.4 GPM @1200 Eng. RPM	X		
61	Hyd. Pump 8.1 GPM @1200 Eng. RPM	X		
71	Hyd. Pump 9.6 GPM @1200 Eng. RPM	X		
82	Hyd. Pump 11.0 GPM @1200 Eng. RPM	X		
87	Hyd. Pump 11.6 GPM @1200 Eng. RPM	X		
1121	Hyd. Pump 2.1 GPM @1000 RPM			X
1126	Hyd. Pump 2.6 GPM @1000 RPM			X
1137	Hyd. Pump 3.7 GPM @1000 RPM			X
1449	Hyd. Pump 4.9 GPM @ 1000 RPM			X
1462	Hyd. Pump 6.2 GPM @1000 RPM			X
AD	SAE A 2-Bolt Flange, SAE AH Shaft (3/4" - 11T)	X		X
SD	Smart Start - Rd Standard Shaft (1-1/4" - 5/16" Key)	X		
XB	1" Round Shaft w/ 1/4" Key			X
XD	Rd Standard Shaft (1-1/4" - 5/16" Key)	X		
XE	SAE A 2 or 4-Bolt Flange, SAE A Shaft (5/8" - 9T)			X
XP	Special SAE A Pilot 2-Bolt Flange, SAE B Shaft (7/8" - 13T)	X		
P37	Hyd. Pump 3.7 GPM @1000 RPM			X
P42	Hyd. Pump 4.2 GPM @1000 RPM			X
P71	Hyd. Pump 7.1 GPM @1000 RPM			X
P82	Hyd. Pump 8.2 GPM @1000 RPM			X
V08	Cartridge @ 1.61 in ³ /rev		X	
V10	Cartridge @ 2.08 in ³ /rev		X	
V12	Cartridge @ 2.26 in ³ /rev		X	
V14	Cartridge @ 2.81 in ³ /rev		X	
V17	Cartridge @ 3.56 in ³ /rev		X	
V20	Cartridge @ 3.89 in ³ /rev		X	
V22	Cartridge @ 4.29 in ³ /rev		X	
V25	Cartridge @ 4.84 in ³ /rev		X	
VIT	Less Cartridge		X	

NOTE: 249/249V Only can be ordered with Internal Pressure Lube. See model configuration for ordering codes.

NOTE: Always check current price book for available options

Installation Kits			
Series Application	Electric Over Hydraulic 12 Volt		
	G - Metric Mount (Allison)	D - Dodge/Aisin	R - Ram/Aisin
252 w/o EOC	329296-8X	329296-9X	329669-12X

NOTE: Dodge/RAM Mounting Codes by Transmission Model Years

D: AS68RC (MY2010 & Prior)

R: AS66RC (MY2014 & Later Gas engine)

R: AS68RC (MY2011 & 2012)

R: AS69RC (MY2013 & Later Diesel engine)

Options

Installation Kits						
Series Application	Electric Over Hydraulic 12 Volt					
	B Shift Option w/ F Mount	K Shift Option w/ G Mount	B Shift Option w/ F Mount V Arrangement	B Shift Option w/ G Mount V Arrangement	K Shift Option w/F Mount	K Shift Option w/ F Mount V Arrangement
249 w/o EOC	329651X	329804X	N/A	N/A	N/A	N/A
249V w/o EOC	N/A	N/A	329836X	329838X	N/A	N/A
249 w/ EOC	N/A	N/A	N/A	N/A	329652X	N/A
249V w/ EOC	N/A	N/A	N/A	N/A	N/A	329837X

NOTE: Use 329650X - Speed Limiter Control Assembly for all EOC applications

N/A – Non Applicable

PTO Options Chart – PowerShift PTOs		272	272F	272U	282
Lubrication					
P	Pressure Lube	X	X	X	X
R	Pressure Lube Valve Body Rotated 120°	X			X
S	Pressure Lube Valve Body Rotated 240°	X			X
V	Wet Spline Valve Body Rotated 120°	X			X
W	Wet Spline	X			X
X	No Pressure Lube	X			X
Y	Wet Spline Valve Body Rotated 240°	X			X
Shifting					
A	Manual Air Shift	X			X
B	12V Elec/Hyd	X	X	†X	X
D	24V Elec/Hyd	X		†X	X
E	12V Elec/Hyd w/o Installation Kit	X	X		X
G	12V Elec/Hyd Remote Valve w/o EOC	X		†X	X
H	24V Elec/Hyd Remote Valve w/o EOC	X		†X	X
N	24V Elec/Hyd w/o Installation Kit	X			X
J	12V Elec/Air w/ EOC	X			X
K	12V Elec/Hyd w/ EOC	X	X	†X	X
L	24V Elec/Hyd w/ EOC	X		†X	X
P	12V Elec/Air Remote	X			X
Q	24V Elec/Air Remote	X			X
R	12V Elec/Air Remote w/ EOC	X			X
V	Manual Air Shift w/o Installation Kit	X		X	X
1	12V Elec/Air	X			X
2	24V Elec/Air	X			X
3	24V Elec/Air w/ EOC	X			X
4	24V Elec/Air Remote w/ EOC	X			X
Output					
AB	DIN 120 Flange	X	X	†X	X
AC	DIN 100 Flange	X	X	†X	X
BD	Shaft Brake - 1-1/4" Round w/ 5/16" Key	X			X
BV	Shaft Brake - 1410 Series Companion Flange	X			X
RB	Rotatable SAE B 4-Bolt Flange, SAE B Shaft (7/8" - 13T)	X	X	X	X
RE	Rotatable SAE A 2-Bolt Flange, SAE A Shaft (5/8" - 9T)	X	X		X
RF	Rotatable SAE B 2 or 4-Bolt Flange, SAE BB Shaft (1" - 15T)	X	X	X	X
RK	Rotatable SAE B 2 or 4-Bolt Flange, SAE B Shaft (7/8" - 13T)	X	X	X	X
RS	Rotatable SAE C 2 or 4-Bolt Flange, SAE C Shaft (1-1/4" - 14T)	X	X	X	X
RY	Rotatable ISO 7653 Pump Mount DIN 5462 Shaft	X	X	X	X
RZ	Rotatable SAE B 2 or 4-Bolt Flange, SAE C Shaft (1-1/4" - 14T)	X	X	X	X
SD	Smart Start - Rd Standard Shaft (1-1/4" - 5/16" Key)	X	X	†X	X
SV	Smart Start - 1410 Series Companion Flange	X	X	†X	X
XD	Rd Standard Shaft (1-1/4" - 5/16" Key)	X	X	†X	X
XR	Chelsea Special (Cloverleaf), SAE B Shaft (7/8" - 13T)	X	X		X
XV	1410 Series Companion Flange	X	X	†X	X

† Coming Soon

NOTE: Always check current price book for available options

Options

272 Series Installation Kits									
Shift Option	Input Gear	Mounting Option	Hydraulic						
			Integral				Remote		
			12V		24V		12V		24V
			w/o EOC	w/ EOC	w/o EOC	w/ EOC	w/o EOC	w/ EOC	w/o EOC
B	HV	D	329882-12X						
	KU		329884-12X						
			329918X						
	LL		J	329920X					
			H	329922X					
D	HV				329882-24X				
E	LL	All	329952X						
N					Excludes Installation Kit				
G	AJ	D R					329885-12X		
	HV						329842-12X		
	KU						329888-12X		
								329887-12X	
H	AJ							329885-24X	
	HV							329842-24X	
K	HV	D, R F, H		329883X					
	KU		329886X						
	LL		329919X						
L	HV	D, R				329883X			
	KU					329886X			

Shift Option	Input Gear	Manual Air Valve	Air							
			Integral				Remote			
			12V		24V		12V		24V	
			w/o EOC	w/ EOC	w/o EOC	w/ EOC	w/o EOC	w/ EOC	w/o EOC	w/ EOC
A		328388-113X								
1			329893-12X							
2					329893-24X					
3						329894-24X				
4	AJ								329889-24X	
	HV								329890-24X	
J				329894-12X						
P							329891-12X			
Q									329891-24X	
R	AJ							329889-12X		
	HV							329890-12X		
V		Excludes Installation Kit						Excludes Installation Kit		

Options

282 Series Installation Kits						
Shift Option	Hydraulic					
	Integral				Remote	
	12V		24V		12V	24V
	w/o EOC	w/ EOC	w/o EOC	w/ EOC	w/o EOC	w/o EOC
B	328892-12X					
D			328892-24X			
E	Excludes Installation Kit					
G					329885-12X	
H						329885-24X
K		329900X				
L				329900X		
N			Excludes Installation Kit			

Shift Option	Manual Air Valve	Air							
		Integral				Remote			
		12V		24V		12V		24V	
		w/o EOC	w/ EOC	w/o EOC	w/ EOC	w/o EOC	w/ EOC	w/o EOC	w/ EOC
A	328388-113X								
J		329894-12X							
P					329891-12X				
Q							329891-24X		
R						329889-12X			
1		329893-12X							
2			329893-24X						
3				329894-24X					
4									329889-24X
V	Excludes Installation Kit					Excludes Installation Kit			

PTO Options

Options

PTO Options Chart – PowerShift PTO		852	885
Lubrication			
P	Pressure Lube	X	X
X	No Pressure Lube		X
Shifting			
A	Air Shift - Manual		X
B	12V Elec/Hyd	X	
D	24V Elec/Hyd	X	
F	No Valve	X	
J	24V Elec/Air w/ EOC		X
K	12V Elec/Hyd w/ EOC	X	
L	24V Elec/Hyd w/ EOC	X	
N	12V Elec/Air w/ EOC		X
P	12V Elec/Air Shift		X
Q	24V Elec/Air Shift		X
Output			
XS	SAE C 4-Bolt, SAE C Shaft (1-1/4" - 14T)	X	
XS	SAE C 2 or 4-Bolt, SAE C Shaft (1-1/4" - 14T)		X
XU	SAE C 2-Bolt, SAE C Shaft (1-1/4" - 14T)	X	
XV	1410 Series Companion Flange	X	X

NOTE: Always check current price book for available options

PTO Options

PTO Options Chart – PowerShift PTOs	210	280	870	870XL	890	892
Lubrication						
P Internal Pressure Lubrication	x					
P Pressure Lube		x	x			
R Pressure Lube Valve Body Rotated 120°		x	x			
S Pressure Lube Valve Body Rotated 240°		x	x			
V Wet Spline Valve Body Rotated 120°		x	x	x		
Y Wet Spline Valve Body Rotated 240°		x	x	x		
W Wet Spline		x	x	x	x	x
Shifting						
B 12V Elec/Hyd		x	x	x	x	x
B Diesel - 12V Elec/Hyd	x					
B Gas - 12V Elec/Hyd	x					
D 24V Elec/Hyd		x	x	x	x	x
E Reduced Wiring Harness	x					
E 12V Elec/Hyd w/o Installation Kit		x	x	x		
N 24V Elec/Hyd w/o Installation Kit		x	x	x		
K 12V Elec/Hyd Valve - Remote w/ EOC	x	x	x	x	x	x
L 24V Elec/Hyd Valve - Remote w/ EOC		x	x	x	x	x
G 12V Elec/Hyd - Remote w/o EOC		x	x	x	x	x
H 24V Elec/Hyd - Remote w/o EOC		x	x	x	x	x
S Air Shift w/ PTO/Dump Pump Combo Valve w/ Kick Out w/ Neutral Spring Return		x				
T Air Shift w/ PTO/Dump Pump Combo Valve w/o Kick Out w/ Neutral Spring Return		x				
X No Harness	x					
Output						
08 Hyd. Pump 12.5 GPM @1200 Eng. RPM	x					
09 Hyd. Pump 14.6 GPM @1200 Eng. RPM	x					
11 Hyd. Pump 16.7 GPM @1200 Eng. RPM	x					
15 Hyd. Pump 19.7 GPM @1200 Eng. RPM	x					
18 Hyd. Pump 23.6 GPM @1200 Eng. RPM	x					
20 Hyd. Pump 26.3 GPM @1200 Eng. RPM	x					
21 Hyd. Pump 3.3 GPM @1200 Eng. RPM	x					
26 Hyd. Pump 4.1 GPM @1200 Eng. RPM	x					
32 Hyd. Pump 4.9 GPM @1200 Eng. RPM	x					
37 Hyd. Pump 5.7 GPM @1200 Eng. RPM	x					
42 Hyd. Pump 6.6 GPM @1200 Eng. RPM	x					
50 Hyd. Pump 7.8 GPM @1200 Eng. RPM	x					
55 Hyd. Pump 8.6 GPM @1200 Eng. RPM	x					
61 Hyd. Pump 9.4 GPM @1200 Eng. RPM	x					
71 Hyd. Pump 11.1 GPM @1200 Eng. RPM	x					
82 Hyd. Pump 12.7 GPM @1200 Eng. RPM	x					
87 Hyd. Pump 13.5 GPM @1200 Eng. RPM	x					
AB DIN 120 Flange		x	x		x	x
AC DIN 100 Flange		x	x		x	x
AD SAE A 2-Bolt Flange (3/4" - 11T)	x					
AF SAE B 2 or 4-Bolt Flange, SAE BB Shaft (1" - 15T)					x (5)	x (5)
AZ SAE B 2 or 4-Bolt Flange, SAE C Shaft (1-1/4" - 14T)					x (5)	x (5)
BB Shaft Brake - DIN 120 Flange			x			
BC Shaft Brake - DIN 100 Flange			x			
BD Shaft Brake - Rd Standard Shaft (1-1/4" - 5/16" Key)		x				
BV Shaft Brake - 1410 Series Companion Flange		x	x			
CF SAE B 2 or 4-Bolt Flange, SAE BB Shaft (1" - 15T)					x, w (3)	x, w (3)
CK SAE B 2 or 4-Bolt Flange, SAE B Shaft (7/8" - 13T)					x, w (3)	x, w (3)
CS SAE C 4-Bolt Flange, SAE C Shaft (1-1/4" - 14T)					x, w (3)	x, w (3)
CZ SAE B 2 or 4-Bolt Flange, SAE C Shaft (1-1/4" - 14T)					x, w (3)	x, w (3)
DA SAE D 4-Bolt Flange, SAE D Shaft (1-3/4" - 13T)					x, w (5)	x, w (5)

Options

Continued on Next Page

(3) = 3 Assembly Arrangement (5) = 5 Assembly Arrangement w = Wet Spline Option

NOTE: Always check current price book for available options

PTO Options

Options

PTO Options Chart – PowerShift PTOs		210	280	870	870XL	890	892
Output (Cont'd)							
RB	Rotatable SAE B 4-Bolt Flange, SAE B Shaft (7/8" - 13T)		x, w				
RF	Rotatable SAE B 2 or 4-Bolt Flange, SAE BB Shaft (1" - 15T)		x, w	x, w			
RK	Rotatable SAE B 2 or 4-Bolt Flange, SAE B Shaft (7/8" - 13T)		x, w	x, w			
RS	Rotatable SAE C 2 or 4-Bolt Flange, SAE C Shaft (1-1/4" - 14T)		x, w	x, w			
RY	Rotatable ISO 7653 Pump Mount DIN 5462 Shaft		x, w	x, w			
RZ	Rotatable SAE B 2 or 4-Bolt Flange, SAE C Shaft (1-1/4" - 14T)		x, w	x, w			
SB	Smart Start - DIN 120		x	x			
SC	Smart Start - DIN 100		x	x			
SD	Smart Start - Rd Standard Shaft (1-1/4" - 5/16" Key)	x	x				
SV	Smart Start - 1410 Series Companion Flange		x	x			
TF	SAE B 2 or 4-Bolt Rotatable Flange, SAE BB Shaft (1" - 15T)				x		
TK	SAE B 2 or 4-Bolt Rotatable Flange, SAE B Shaft (7/8" - 13T)				x		
TS	SAE C 2 or 4-Bolt Rotatable Flange, SAE C Shaft (1-1/4" - 14T)				x		
TY	DIN 5462 Pump Mount				x		
TZ	SAE B 2 or 4-Bolt Rotatable Flange, SAE C Shaft (1-1/4" - 14T)				x		
XD	Rd Standard Shaft (1-1/4" - 5/16" Key)		x				
XK	SAE B 2 or 4-Bolt Flange, SAE B Shaft (7/8" - 13T)					x, w (5)	x, w (5)
XP	SAE A Pilot 2-Bolt Flange, SAE B Shaft (7/8" - 13T)	x					
XR	Chelsea Special (Cloverleaf), SAE B Shaft (7/8" - 13T)		x				
XS	SAE C 2 or 4-Bolt Flange, SAE C Shaft (1-1/4" - 14T)					x, w (5)	x, w (5)
XV	1410 Series Companion Flange		x	x		x	x
XY	ISO 7653 Pump Mount DIN 5462 Shaft					x, w	x, w
ZS	SAE C 4-Bolt Flange, SAE C Shaft (1-1/4" - 14T)					x	x

(3) = 3 Assembly Arrangement (5) = 5 Assembly Arrangement w = Wet Spline Option

NOTE: Always check current price book for available options

Installation Kits						
Series Application	Electric Over Hydraulic w/ Remote Valve		Electric Over Hydraulic		PTO/Dump (S)	PTO/Dump (T)
	12 Volt	24 Volt	12 Volt	24 Volt		
Allison (FJ) 280/870 w/o EOC 280/870 w/ EOC	329237-12X	329237-24X	329024-12X 329076X	329024-24X 329076X		
280 w/ PTO Dump Pump Valve					328388-65X	328388-86X
890/892 w/o EOC 890/892 w/ EOC	329653-12X	329653-24X	329024-12X 329076X	329024-24X 329076X		
Caterpillar (KV) 280/870 w/o EOC 280/870 w/EOC	329445-12X	329445-24X	329443-12X 329444X	329443-24X 329444X		
280 w/ PTO Dump Pump Valve					328388-65X	328388-86X

NOTE: Controls for Electronic Overspeed Control (EOC) - 329650X

Conversion Kits				
Series Application	Electric Over Hydraulic w/ Remote Valve		Electric Over Hydraulic	
	12 Volt	24 Volt	12 Volt	24 Volt
(FJ & KV) 280/870 w/ EOC	329354-12X	329354-24X		
Allison (FJ) 280/870 w/o EOC			329175-12X	329175-24X
Caterpillar (KV) 280/870 w/ EOC			329448-12X	329448-24X

PTO Options Chart – Constant Mesh PTOs		267*	287	877	877XL	897	899
Lubrication							
P	Pressure Lube	x	x	x			
R	Pressure Lube Valve Body Rotated 120°		x				
S	Pressure Lube Valve Body Rotated 240°		x				
V	Wet Spline Valve Body Rotated 120°		x				
W	Wet Spline	x	x	x	x	x	x
Y	Wet Spline Valve Body Rotated 240°		x				
Shifting							
M	Constant Mesh	x	x	x	x	x	x
Output							
AB	DIN 120 Flange		x	x		x	x
AC	DIN 100 Flange		x	x		x	x
AF	SAE B 2 or 4-Bolt Flange, SAE BB Shaft (1" - 15T)	x, w				x, w (5)	x, w (5)
AK	SAE B 2-Bolt Flange, SAE B Shaft (7/8" - 13T)	x, w					
AZ	SAE B 2 or 4-Bolt Flange, SAE C Shaft (1-1/4" - 14T)					x, w (5)	x, w (5)
AZ	SAE B 4-Bolt Flange, SAE C Shaft (1-1/4" - 14T)	x					
CF	SAE B 2 or 4-Bolt Flange, SAE BB Shaft (1" - 15T)					x, w (3)	x, w (3)
CK	SAE B 2 or 4-Bolt Flange, SAE B Shaft (7/8" - 13T)					x, w (3)	x, w (3)
CS	SAE C 4-Bolt Flange, SAE C Shaft (1-1/4" - 14T)					x, w (3)	x, w (3)
CZ	SAE B 2 or 4-Bolt Flange, SAE C Shaft (1-1/4" - 14T)					x, w (3)	x, w (3)
DA	SAE D 4-Bolt Flange, SAE D Shaft (1-3/4" - 13T)					x, w (5)	x, w (5)
GA	Greaseable SAE B 2-Bolt Rotatable Flange, SAE B Shaft (7/8" - 13T)	x					
GB	Greaseable SAE B 4-Bolt Rotatable Flange, SAE B Shaft (7/8" - 13T)	x					
GF	Greaseable SAE B 2 or 4-Bolt Flange, SAE BB Shaft (1" - 15T)	x					
GK	Greaseable SAE B 2 or 4-Bolt Flange, SAE B Shaft (7/8" - 13T)	x					
GQ	Greaseable SAE B 2 or 4-Bolt Flange, SAE B Shaft (7/8" - 13T)	x, w					
GR	Greaseable Chelsea Special (Cloverleaf), SAE B Shaft (7/8" - 13T)	x					
RA	Rotatable SAE B 2-Bolt Flange, SAE B Shaft (7/8" - 13T)	x					
RB	Rotatable SAE B 4-Bolt Flange, SAE B Shaft (7/8" - 13T)	x	x, w				
RC	Rotatable SAE A 2-Bolt Flange, SAE A Shaft (5/8" - 9T)	x					
RD	Rotatable SAE A 2-Bolt Flange, SAE B Shaft (7/8" - 13T)	x					
RE	Rotatable SAE B 4-Bolt Flange, SAE BB Shaft (1" - 15T)	x					
RF	Rotatable SAE B 2-Bolt Flange, SAE BB Shaft (1" - 15T)	x					
RF	Rotatable SAE B 2 or 4-Bolt Flange, SAE BB Shaft (1" - 15T)		x, w	x, w			
RJ	Rotatable SAE B 2 or 4-Bolt Flange, SAE BB Shaft (1" - 15T)	x					
RK	Rotatable SAE B 2 or 4-Bolt Flange, SAE B Shaft (7/8" - 13T)	x	x, w	x, w			
RS	Rotatable SAE C 2 or 4-Bolt Flange, SAE C Shaft (1-1/4" - 14T)		x, w	x, w			
RY	Rotatable ISO 7653 Pump Mount DIN 5462 Shaft	x, w	x, w	x, w			
RZ	Rotatable SAE B 2 or 4-Bolt Flange, SAE C Shaft (1-1/4" - 14T)		x, w	x			
TF	SAE B 2 or 4-Bolt Rotatable Flange, SAE BB Shaft (1" - 15T)				x		
TK	SAE B 2 or 4-Bolt Rotatable Flange, SAE B Shaft (7/8" - 13T)				x		
TS	SAE C 2 or 4-Bolt Rotatable Flange, SAE C Shaft (1-1/4" - 14T)				x		
TV	Tapered Shaft with 1410 Series Companion Flange	x					
TY	DIN 5462 Pump Mount				x		
TZ	SAE B 2 or 4-Bolt Rotatable Flange, SAE C Shaft (1-1/4" - 14T)				x		
XD	Rd Standard Shaft (1-1/4" - 5/16" Key)	x	x				
XE	SAE A 2 or 4-Bolt Flange, SAE A Shaft (5/8" - 9T)	x					
XK	SAE B 2 or 4-Bolt Flange, SAE B Shaft (7/8" - 13T)	x, w				x, w (5)	x, w (5)
XQ	SAE B 2 or 4-Bolt Flange, SAE B Shaft (7/8" - 13T)	x, w					
XR	Chelsea Special (Cloverleaf), SAE B Shaft (7/8" - 13T)	x					
XS	SAE C 2 or 4-Bolt, SAE C Shaft (1-1/4" - 14T)					x, w (5)	x, w (5)
XV	1410 Series Companion Flange		x	x		x	x
XX	1-1/4" Tapered Output Shaft w/ Keyway	x (5)					
XY	ISO 7653 Pump Mount DIN 5462 Shaft	x				x, w	x, w
ZS	SAE C 4-Bolt Flange, SAE C Shaft (1-1/4" - 14T)					x, w	x, w

* Any 267 Series using a 3 Arrangement requiring a SAE B Output must use the XQ or AK Output Option due to interference between the XK Flange and the Pressure Lube Fitting.

(3) = 3 Assembly Arrangement

(5) = 5 Assembly Arrangement

w = Wet Spline Option

NOTE: Always check current price book for available options

For converting Chelsea PowerShift PTOs from a driveshaft output (XD or XV) to a pump flange output and/or a wet spline output.

267 Series

Pump Suffix	Kit Number	Assembly	Flange Type	Shaft Type (SAE)
AF	328591-129X	3, 4, 5 & 6	SAE B 2 or 4-Bolt	1" - 15 Tooth Splined (BB)
AK	328591-141X	3, 4, 5 & 6	SAE B 2-Bolt	7/8" - 13 Tooth Splined (B)
AZ	328591-70X	3, 4, 5 & 6	SAE B 2 or 4-Bolt	1-1/4" - 14 Tooth Splined (C)
XE	328591-27X	4, 5 & 6	SAE A 2 or 4-Bolt	5/8" - 9 Tooth Splined (A)
XK	328591-16X			
XK (B Ratio)	329436-3X	3, 4, 5 & 6	SAE B 2 or 4-Bolt	7/8" - 13 Tooth Splined (B)
XK (Wet Spline)	328591-157X			
XQ	328591-17X	3, 4, 5 & 6	SAE B 2 or 4-Bolt	7/8" - 13 Tooth Splined (B)
XQ (B Ratio)		3, 4, 5 & 6		
XR	328591-52X	3, 4, 5 & 6	Chelsea Special (Cloverleaf)	7/8" - 13 Tooth Splined (B)
XX	328591-122X	3, 4, 5 & 6	Not Included	1-1/4" Tapered Output Shaft w/ Keyway
XY	328591-121X	3, 4, 5 & 6	ISO 7653 Pump Mount	DIN 5462 (B8x32x36 - 8T)
RC (Rotatable)	328591-112X	3, 4, 5 & 6	SAE A 2-Bolt	5/8" - 9 Tooth Splined (A)
RA (XD to RA)	328591-55X			
RA (XR to RA)	328591-53X	3, 4, 5 & 6	SAE B 2-Bolt	7/8" - 13 Tooth Internal Spline (B)
RA (XD to RA) (B Ratio)	329436-1X			
RF (Rotatable)	328591-78X	3, 4, 5 & 6	SAE B 2-Bolt	1" - 15 Tooth Splined (BB)
RB (XR to RB)	328591-54X			
RB (XD to RB)	328591-56X	3, 4, 5 & 6	SAE B 4-Bolt	7/8" - 13 Tooth Internal Spline (B)
RB (XD to RB) (B Ratio)	329436-2X			
RK (Rotatable)	329973X 329974X	3, 4, 5 & 6	SAE B 2 or 4-Bolt Rotatable	7/8" - 13 Tooth Splined (B)
RY (Rotatable)	328591-132X 328591-131X	3, 4, 5 & 6	ISO 7653 Pump Mount	DIN 5462 (B8x32x36 - 8T)
GA (Greaseable)	328591-72X	3, 4, 5 & 6	SAE B 2-Bolt Rotatable	*7/8" - 13 Tooth Internal Spline (B)
GB (Greaseable)	328591-74X	3, 4, 5 & 6	SAE B 4-Bolt Rotatable	*7/8" - 13 Tooth Internal Spline (B)
GK (XD to GK)	328591-89X	3, 4, 5 & 6	SAE B 2 or 4-Bolt	*7/8" - 13 Tooth Internal Spline (B)
GK (XK to GK)	328591-86X			
GQ (XD to GQ)	328591-91X	3, 4, 5 & 6	SAE B 2 or 4-Bolt	*7/8" - 13 Tooth Internal Spline (B)
GQ (XQ to GQ)	328591-86X			
GF (XD to GF)	328591-71X			
GF (AF to GF)	328591-108X	3, 4, 5 & 6	SAE B 2 or 4-Bolt	*1" - 15 Tooth Internal Spline (BB)
GF (RF to GF)	328591-114X			
GR (Greaseable)	328591-76X	3, 4, 5 & 6	Chelsea Special (Cloverleaf)	*7/8" - 13 Tooth Internal Spline (B)

*Grease fitting on end of shaft

NOTE: Use 329097-1X to convert PTOs with AK, XP, XQ, XN, or XK output to the self-lube pump option.

NOTE: Contact Chelsea Customer Service for kits not listed.

PTO Options Chart – Split Shaft PTOs		901	912
Shifting			
A	Air Shift	x	x
Y	Lever Shift	x	x
Input-Output Shaft			
C	1-3/4" - 10T Spline Input-Output	x	
G	2-3/4" w/ 1710 1/2 Rd. Yoke		x
H	2-3/4" w/ 1810 1/2 Rd. Yoke		x
J	2-3/4" Input-Output w/o Yoke		x
M	2-3/4" w/ 1610 Companion Flange		x
P	SPL-170 Yoke		x
S	SPL-250 Yoke		x
PTO Output Shaft			
XK	SAE B 2 or 4-Bolt Flange, SAE B Shaft (7/8" - 13T)	x	
XS	SAE C 4-Bolt, SAE C Shaft (1-1/4" - 14T)	x	
XU	SAE C 2-Bolt Flange, SAE C Shaft (1-1/4" - 14T)	x	
XV	1410 Series Companion Flange	x	
XX	8-Bolt Apertures Available		x

Specifications Chart – 901 Series	
Standard Output Shaft Size	— 1-3/4" - 10 Tooth —
Intermittent Torque Rating (lbs-ft)	500
Intermittent Torque Rating (Nm)	678
Horsepower Rating for Intermittent Service	
At 500 RPM of the Output Shaft (HP)	48
At 1000 RPM of the Output Shaft (HP)	95
At 500 RPM of the Output Shaft (Kw)	36
At 1000 RPM of the Output Shaft (Kw)	75
Approximate Weight:	— 185 lbs. [84 kg] —

Specifications Chart – 912 Series		
Standard Output Shaft Size	— 2-3/4" - 10 Tooth —	
Max Thru Torque Capacity	lbs-ft	Nm
w/ Diesel Engine		
Automatic Transmission	13,000	17,625
Manual Transmission	12,000	16,270
w/ Gas Engine		
Automatic Transmission	16,000	21,693
Manual Transmission	15,000	20,337
Approximate Weight:	— 130 lbs. [59 kg] —	

PTO Options Chart – Crank Shaft PTO		2442
Shifting		
A	Air Shift	X
C	Heavy Duty Bracket less Cable	X
H	No Shift Assembly	X
M	Constant Mesh	X
P	12V Elec/Air	X
S	Air Shift w/ PTO/Dump Pump Combo Valve w/ Kick Out w/ Neutral Spring Return	X
T	Air Shift w/ PTO/Dump Pump Combo Valve w/o Kick Out w/ Neutral Spring Return	X
U	Air Shift w/ PTO/Dump Pump Combo Valve w/ Kick Out w/o Neutral Spring Return	X
V	Air Shift less Installation Kit	X
W	Cable Shift	X
X	Less Cable & Knob	X
Output		
AF	SAE B 2 or 4-Bolt Flange, SAE BB Shaft (1" - 15T)	X
AK	SAE B 2-Bolt Flange, SAE B Shaft (7/8" - 13T)	X
AZ	SAE B 4-Bolt Flange, SAE C Shaft (1-1/4" - 14T)	X
GA	Greaseable SAE B 2-Bolt Rotatable Flange, SAE B Shaft (7/8" - 13T)	X
GB	Greaseable SAE B 4-Bolt Rotatable Flange, SAE B Shaft (7/8" - 13T)	X
GF	Greaseable SAE B 2 or 4-Bolt Flange, SAE BB Shaft (1" - 15T)	X
GK	Greaseable SAE B 2 or 4-Bolt Flange, SAE B Shaft (7/8" - 13T)	X
GQ**	Greaseable SAE B 2 or 4-Bolt Flange, SAE B Shaft (7/8" - 13T)	X
GR	Greaseable Chelsea Special (Cloverleaf), SAE B Shaft (7/8" - 13T)	X
RA	Rotatable SAE B 2-Bolt Flange, SAE B Shaft (7/8" - 13T)	X
RB	Rotatable SAE B 4-Bolt Flange, SAE B Shaft (7/8" - 13T)	X
RC	Rotatable SAE A 2-Bolt Flange, SAE A Shaft (5/8" - 9T)	X
RD	Rotatable SAE A 2-Bolt Flange, SAE B Shaft (7/8" - 13T)	X
RE	Rotatable SAE B 4-Bolt Flange, SAE BB Shaft (1" - 15T)	X
RF	Rotatable SAE B 2-Bolt Flange, SAE BB Shaft (1" - 15T)	X
RK	Rotatable SAE B 2 or 4-Bolt Flange, SAE B Shaft (7/8" - 13T)	X
RY	Rotatable ISO 7653 Pump Mount DIN 5462 Shaft	X
SQ	SAE B 4-Bolt Flange, SAE B Shaft (7/8" - 13T)	X
XD	Rd Standard Shaft (1-1/4" - 5/16" Key)	X
XE	SAE A 2 or 4-Bolt Flange, SAE A Shaft (5/8" - 9T)	X
XK	SAE B 2 or 4-Bolt Flange, SAE B Shaft (7/8" - 13T)	X
XQ**	SAE B 2 or 4-Bolt Flange, SAE B Shaft (7/8" - 13T)	X
XR	Chelsea Special (Cloverleaf), SAE B Shaft (7/8" - 13T)	X
XX***	1-1/4" Tapered Output Shaft w/ Keyway	X
XY	ISO 7653 Pump Mount DIN 5462 Shaft	X

** XQ/GQ same as XK/GK except flange rotated 90°

*** Order companion (379824) separately

NOTE: Always check current price book for available options

Output Conversion Kits

For converting the 2442 Series Chelsea PTOs from a driveshaft output or as listed to a new pump flange output, use the following kits. Consult the Chelsea price book for availability by series.

Pump Suffix	Kit Number Suffix	Kit Number	Flange Type	Shaft Type
AF	XD to AF	328591-30X	SAE B 2 or 4-Bolt	1" - 15 Tooth Splined (BB)
AK	XD to AK	328591-28X	SAE B 2-Bolt	7/8" - 13 Tooth Splined (B)
AZ	XD to AZ	328591-70X	SAE B 2 or 4-Bolt	1-1/4" - 14 Tooth Splined (C)
XE	XD to XE	328591-27X	SAE A 2 or 4-Bolt	5/8" - 9 Tooth Splined (A)
XK	XD to XK	328591-16X	SAE B 2 or 4-Bolt	7/8" - 13 Tooth Splined
	(B Ratio)	329436-3X		
XQ	XD to XQ	328591-17X	SAE B 2 or 4-Bolt	7/8" - 13 Tooth Splined (B)
	(B Ratio)	329436-6X		
XR	XD to XR	328591-52X	Chelsea Special (Cloverleaf)	7/8" - 13 Tooth Splined (B)
XX	XD to XX	328591-122X	Not Included	1-1/4" Tapered Output Shaft w/ Keyway
XY	XD to XY	328591-121X	ISO 7653 Pump Mount	DIN 5462 (B8x32x36 - 8T)
RC (Rotatable)	XD to RC	328591-112X	SAE A 2-Bolt	7/8" - 9 Tooth Splined (A)
RD (Rotatable)	XD to RD	328591-113X	SAE A 2-Bolt	7/8" - 13 Tooth Splined (B)
	(B Ratio)	329436-8X		
RA (Rotatable)	XD to RA	328591-55X	SAE B 2-Bolt	7/8" - 13 Tooth Splined (B)
	XR to RA	328591-53X		
	(B Ratio)	329436-1X		
RF (Rotatable)	XD to RF	328591-78X	SAE B 2-Bolt	1" - 15 Tooth Splined (BB)
RB (Rotatable)	XD to RB	328591-56X	SAE B 4-Bolt	7/8" - 13 Tooth Splined (B)
	XR to RB	328591-54X		
	(B Ratio)	329436-2X		
RE (Rotatable)	XD to RE	328591-134X	SAE B 4-Bolt	1" - 15 Tooth Splined (BB)
RK (Rotatable)	XD to RK (Wet Spline)	328591-160X	SAE B 2 or 4-Bolt Rotatable	7/8" - 13 Tooth Splined (B)
	(Dry Spline)	328591-159X		
RY (Rotatable)	XD to RY	328591-131X	ISO 7653 Pump Mount	DIN 5462 (B8x32x36 - 8T)
GA (Greaseable)	XD to GA	328591-72X	SAE B 2-Bolt Rotatable	*7/8" - 13 Tooth Splined (B)
	XR to GA	328591-73X		
	RA to GA	328591-106X		
GB (Greaseable)	XD to GB	328591-74X	SAE B 4-Bolt Rotatable	*7/8" - 13 Tooth Splined (B)
	XR to GB	328591-75X		
	RB to GB	328591-107X		
GK (Greaseable)	XD to GK	328591-89X	SAE B 2 or 4-Bolt	7/8" - 13 Tooth Splined
	XK to GK	328591-86X		
GQ (Greaseable)	XD to GQ	328591-91X	SAE B 2 or 4-Bolt	*7/8" - 13 Tooth Splined (B)
	XQ to GQ	328591-86X		
GF (Greaseable)	XD to GF	328591-71X	SAE B 2 or 4-Bolt	*1" - 15 Tooth Splined (BB)
	AF to GF	328591-108X		
	RF to GF	328591-114X		
GR (Greaseable)	XD to GR	328591-76X	Chelsea Special (Cloverleaf)	*7/8" - 13 Tooth Splined (B)

*Grease fitting on end of shaft

NOTE: Contact Chelsea Customer Service for kits not listed.

A Guide to Specifying Chelsea Geared Adapters

When you need to change PTO output shaft rotation or clear a mounting obstacle, a geared adapter may be required. However, it is important to note the following:

- Geared adapters will change the direction of PTO rotation. Consider this when specifying driven equipment.
- Not all applications can use geared adapters. These situations are called out on the bottom of the Chelsea applications catalog pages. Check there before you spend time trying to specify a geared adapter.
- If an application cannot use an adapter, consider changing the PTO assembly arrangement, moving the PTO to the other side of the transmission, or using a change rotation gear box.
- Adapters are not available for use with PTOs on automatic transmissions except the Allison 1000, 2000/2400 Series.
- Adapters are not available for use with 8-Bolt PTOs.
- Current model Chelsea adapters do not change the PTO speed.

Standard Geared Adapter Assemblies

Assembly Number	Figure Number	Number of Teeth	A Body Thickness or Degree of Angularity	B Pitch Line to Outer Face	C Pitch Line to Inner Face
328530-1X	1	22	1.650"	1.085"	3.100"
328530-2X	1	18	1.650"	1.117"	3.067"
328554-1X	2	19	22°	1.085"	1.110"
329138X,-1X	3	24	49°	1.085"	1.085"

Figure 1

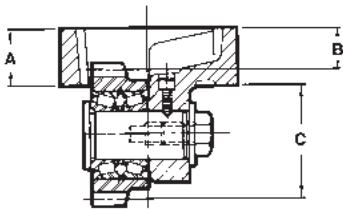

328530-1X
328530-2X

Figure 2

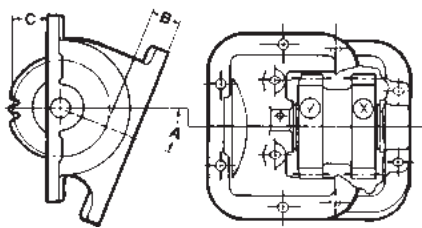

328554-1X

Figure 3

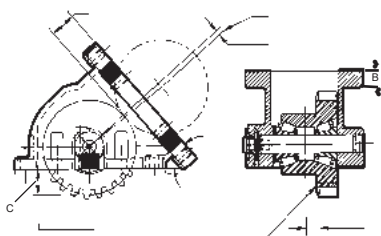

329138X,-1X

Where Used

328530-1X, -2X:

Use on either side, any assembly arrangement, where the transmission gear pitch and pressure angle allows. These adapters will move the PTO straight out from the transmission. These are deep reach geared adapters that generally require the use of extra spacers and special stud kits.

328554-1X:

Use on the R.H. side of transmissions with a 6 pitch 20° pressure angle PTO drive gear located towards the front of the opening. The adapter will move the PTO down and towards the rear of the truck. Use a PTO with a 3 assembly and an AH gear designator. This adapter requires the application to be derated by 30%.

329138X:

Use on the R.H. side of transmissions with a 6 pitch 20° pressure angle PTO drive gear located towards the **front** of the truck, or on the L.H. when the PTO drive gear is located towards the **rear** of the truck. The adapter will drop the PTO down at a 49° angle. Use PTOs with the same assembly arrangement and gear detail as shown in the application catalog.

329138-1X:

Use on the R.H. side of transmissions with a 6 pitch 20° pressure angle PTO drive gear located towards the **rear** of the truck, or on the L.H. when the PTO drive gear is located towards the **front** of the truck. The adapter will drop the PTO down at a 49° angle. Use PTOs with the same assembly arrangement and gear detail as shown in the application catalog.

When a geared adapter can be used, four steps will help you specify it correctly.

1. Identify the correct gear detail and gear location.
2. Select the style that will perform the necessary function.
3. Calculate the correct backlash/spacing.
4. Select the correct stud kit.

Step 1: Identify the Gear Detail and Gear Location

The first step is to find adapters that will fit your application.

At the top of each transmission application page, Chelsea lists gear data. For example, on FLR-34, on the right hand side, the transmission gear is a 6 pitch, 20° spur gear (AH Input Gear). The transmission gear is forward of the centerline of the PTO opening.

To select an adapter for this application, look only at adapters that have a 6 pitch, 20° spur gear (AH Input Gear) that is forward of the adapter body centerline when used on the right hand side of a transmission.

NOTE: If gear pitch unknown contact Chelsea Customer Service.

Step 2: Select the Style

The second step is to further narrow down your choices according to your application requirement.

If the purpose of specifying a geared adapter is simply to change rotation, look for the least expensive adapter available. Typically, this means an adapter that will bring the PTO straight out from the transmission. Also check whether the adapter requires you to derate the PTO torque rating. This occurs when the adapter contains needle bearings rather than roller bearings.

If the purpose of specifying a geared adapter is to clear mounting obstacles, determine whether moving the PTO away from the transmission is enough, or whether it is necessary to angle the PTO down to clear the object.

Always keep in mind how much room you have to work with and what mounting obstacles exist.

For our example, let's say we have 328530-1X on the shelf and it looks like it will work.

Step 3: Calculate the Backlash and Spacing.

Next, you must establish correct backlash between the transmission and the geared adapter. To do this, calculate the adapter P.L. (pitch line) to inner face dimension minus the transmission pitch line to aperture face dimension.

On page 2.30 of this booklet, we see that the adapter P.L. (pitch line) to inner face dimension for adapter 328530-1X is 3.100. On FLR-34 application page, for the right hand opening, we see that the P.L. (pitch line) to aperture face dimension for the transmission is 1.0850.

$$\begin{array}{r} 3.100 \text{ (adapter pitch line to inner face dimension)} \\ - 1.085 \text{ (transmission P.L. to aperture face dimension)} \\ \hline 2.015 \end{array}$$

In this example, we would need to back the adapter away from the transmission gear 2.015" to establish correct backlash. We would select a 7-A-2000 filler block (page 2.22 of this booklet), and use a thin gasket (.010") on each side of the filler block.

Our theoretical backlash is .003". We need to have between .006" and .012". Most likely, once the adapter is actually mounted and backlash is measured, it will fall between the accepted range. This is because the transmission case and the adapter may vary a few thousandths from the listed measurements.

NOTE: It is always the responsibility of the installer to measure and establish correct backlash. Follow the instructions given in the PTO Owner's Manual and the Adapter Gears Owner's Manual.

Step 4: Select the Correct Stud Kit

To calculate the necessary length of the mounting studs for a PTO/adaptor combination, add the following dimensions together:

- Transmission Thread Depth
- + Lock Nut Thickness
- + Body Thickness of Adapter
- + Spacer/Filler Block Thickness
- + PTO mounting flange Thickness
- + Crush Thickness of Gaskets between the transmission, adapter, and PTO collectively
- + 1/16" Extra Length
- Required Stud Length

Example:

- .500" – Transmission Thread Depth (Example Only)
- + .380" – Lock Nut Thickness
- + 1.650" – 328530-1X Body Thickness of Adapter
- + .240" – 7-A-240 Spacer/Filler Block Thickness
- + .793" – PTO Mounting Flange Thickness
- + .024" – (4) 35-P-9-1 Gaskets* - Crush Thickness
- + .0625" – Extra Length
- 3.6495" (3.65") – Total Stud Length

Stud kit 328170-168X contains studs that are 3.750" long. Stud kits are listed in Chelsea publication HY25-2002-M1/US.

Remember that each application is different. It is up to the installer to make sure backlash between the transmission and adapter, and between the adapter and the PTO, is correct.

The 626, 628, 630 and 645 family of adapters are designed to simplify your selection and installation of a geared adapter when you require a change in rotation or are trying to clear an obstacle.

These adapters use the same input gears as the 442 and 489 Series PTOs, and are available in kits. The 626 adapter fits a 6-Bolt opening and moves the PTO straight out from the transmission. The 630 fits a 6-Bolt opening and angles the PTO down at a 30° angle. The 645 fits a 6-Bolt opening and angles the PTO down at a 45° angle. The 628 adapter fits an 8-Bolt transmission opening and accommodates a 6-Bolt PTO.

The 626, 630 and 645 adapter assemblies have the same pitch line to mounting face dimensions as the 442 Series, while the 628 will have the same mounting dimensions as the 489 Series. This means the same mounting hardware and spacers you use to mount the PTO to a specific application will be the same hardware you use to mount the geared adapter to that application.

Using the 626, 628, 630 or 645 will change the direction of PTO rotation. It will not change the speed of the PTO.

* A .010" gasket will compress to .006" if the capscrews or nuts are torqued properly. A .020" will compress to .012".

626 Series

Six Bolt to Six Bolt Straight

- 6-Bolt PTO for a 6-Bolt Transmission Opening
- Moves the PTO straight out from the transmission
- Uses the same input gears as the 442 and 489 Series
- Uses the same mounting hardware and spacers used to mount a 442 Series to a specific application

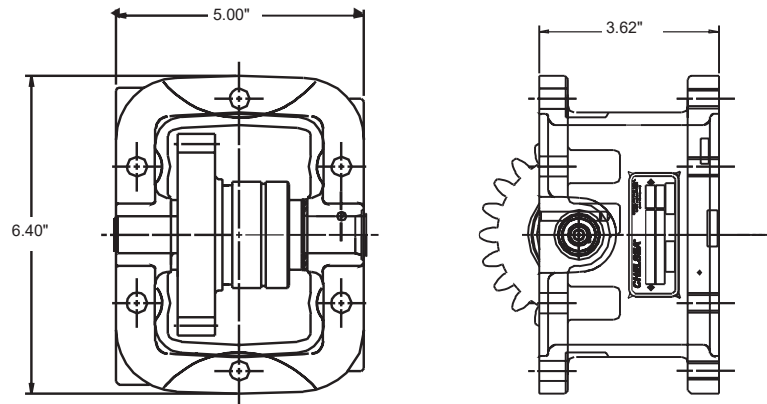

628 Series

Eight Bolt to Six Bolt Straight

- 6-Bolt PTO for a 8-Bolt Transmission Opening
- Moves the PTO straight out from the transmission
- Uses the same input gears as the 442 and 489 Series
- Uses the same mounting hardware and spacers used to mount a 489 Series to a specific application

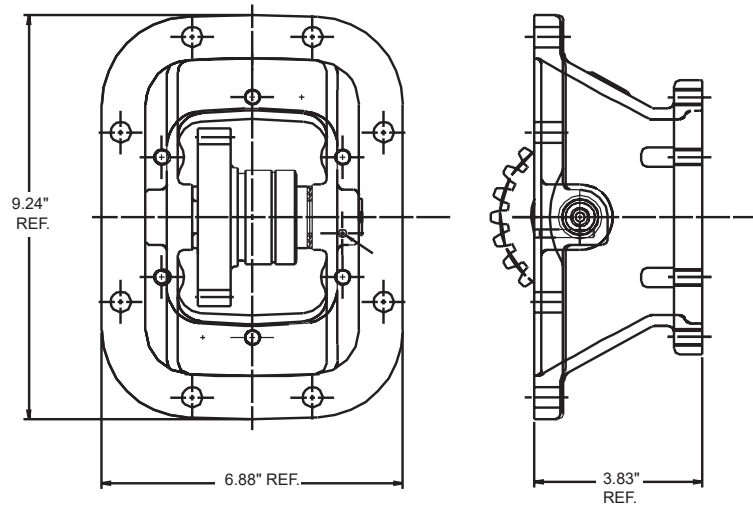

Options

630 Series**Six Bolt to Six Bolt 30 Degrees**

- 6-Bolt PTO for a 6-Bolt Transmission Opening
- Moves the PTO down at a 30° angle, helping to eliminate interference problems
- Uses the same input gears as the 442 and 489 Series

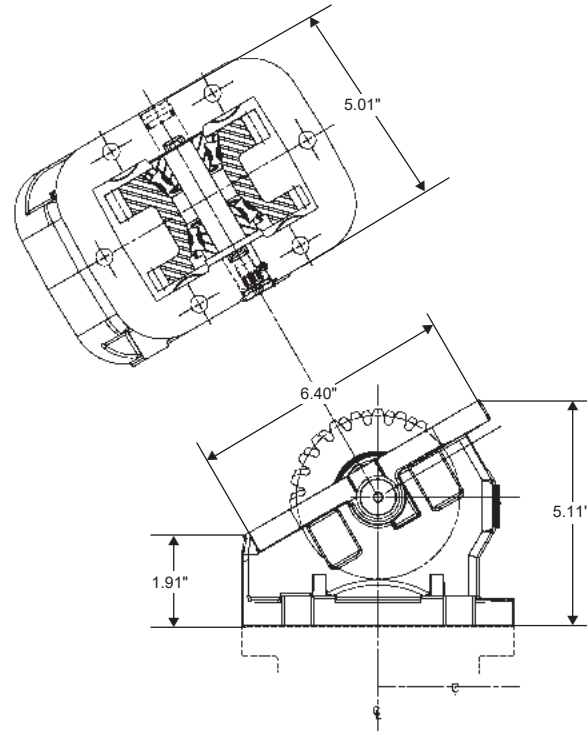
**645 Series****Six Bolt to Six Bolt 45 Degrees**

- 6-Bolt PTO for a 6-Bolt Transmission Opening
- Moves the PTO down at a 45° angle, helping to eliminate interference problems
- Uses the same input gears as the 442 and 489 Series

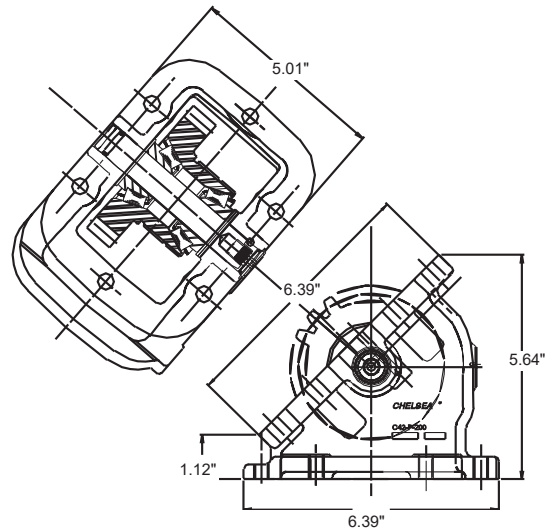

626 Gear Chart

Adapter Input Gear				Mounting Information PTO to Adapter		PTO Gear (Packaged Loose w/Adapter)			
Model No.	Part No.	Helix Angle	No. Teeth	Spacer Designator	Stud Kit	PTO Pitch	Part No.	Helix Angle	No. Teeth
626*AH	5-P-1004	Spur	22	7-A-140	7170-3X	—**AH	5-P-1004	Spur	22
626*AR	5-P-1008	Left Hand	21	7-A-187	7170-3X	—**GY	5-P-1184	Right Hand	21
626*BG	5-P-1015	Left Hand	23	7-A-140	7170-3X	—**HB	5-P-1187	Right Hand	23
626*BQ	5-P-1023	Left Hand	25	7-A-200	7170-4X	—**BP	5-P-1022	Right Hand	26
626*DA	5-P-1037	Spur	23	—	—	—**DA	5-P-1037	Spur	23
626*DU	5-P-1050	Left Hand	28	7-A-240	7170-4X	—**HH	5-P-1193	Right Hand	28
626*ES	5-P-1059	Left Hand	22	7-A-062	—	—**HL	5-P-1196	Right Hand	22
626*EV	5-P-1060	Spur	40	7-A-300	7170-4X	—**EV	5-P-1060	Spur	40
626*EW	5-P-1061	Left Hand	20	7-A-125	7170-3X	—**HM	5-P-1197	Right Hand	20
626*FN	5-P-1070	Left Hand	26	7-A-300	7170-4X	—**HR	5-P-1201	Right Hand	26
626*HY	5-P-1237	Left Hand	26	7-A-125	328170-94X	—**JB	5-P-1244	Right Hand	26
626*JK	5-P-1261	Left Hand	24	7-A-187	7170-3X	—**JL	5-P-1262	Right Hand	24
626*JU	5-P-1316	Left Hand	25	7-A-200	7170-4X	—**KA	5-P-1318	Right Hand	25
626*JW	5-P-1319	Left Hand	23	7-A-093	7170-3X	—**KB	5-P-1321	Right Hand	23
626*IT	KIT ADAPTER	—	—	—	—	—	—	—	—

Options

628 Gear Chart

Adapter Input Gear				Mounting Information PTO to Adapter		PTO Gear (Packaged Loose w/Adapter)			
Model No.	Part No.	Helix Angle	No. Teeth	Spacer Designator	Stud Kit	PTO Pitch	Part No.	Helix Angle	No. Teeth
628*AH	5-P-1004	Spur	22	7-A-165	7170-3X	—**AH	5-P-1004	Spur	22
628*AR	5-P-1008	Left Hand	21	7-A-200	7170-3X	—**GY	5-P-1184	Right Hand	21
628*BG	5-P-1015	Left Hand	23	7-A-165	7170-3X	—**HB	5-P-1187	Right Hand	23
628*DA	5-P-1037	Spur	23	—	328170-76X	—**DA	5-P-1037	Spur	23
628*DU	5-P-1050	Left Hand	28	7-A-270	7170-5X	—**HH	5-P-1193	Right Hand	28
628*EV	5-P-1060	Spur	40	7-A-300	7170-5X	—**EV	5-P-1060	Spur	40
628*IT	KIT ADAPTER	—	—	—	—	—	—	—	—

630 Gear Chart

Adapter Input Gear				Mounting Information PTO to Adapter		PTO Gear (Packaged Loose w/Adapter)			
Model No.	Part No.	Helix Angle	No. Teeth	Spacer Designator	Stud Kit	PTO Pitch	Part No.	Helix Angle	No. Teeth
630*AH	5-P-1004	Spur	22	7-A-140	7170-3X	—**AH	5-P-1004	Spur	22
630*AR	5-P-1008	Left Hand	21	7-A-187	7170-3X	—**GY	5-P-1184	Right Hand	21
630*BG	5-P-1015	Left Hand	23	7-A-140	7170-3X	—**HB	5-P-1187	Right Hand	23
630*BQ	5-P-1023	Left Hand	25	7-A-200	7170-4X	—**BP	5-P-1022	Right Hand	26
630*DA	5-P-1037	Spur	23	—	—	—**DA	5-P-1037	Spur	23
630*DU	5-P-1050	Left Hand	28	7-A-240	7170-4X	—**HH	5-P-1193	Right Hand	28
630*ES	5-P-1059	Left Hand	22	7-A-062	—	—**HL	5-P-1196	Right Hand	22
630*EV	5-P-1060	Spur	40	7-A-300	7170-4X	—**EV	5-P-1060	Spur	40
630*EW	5-P-1061	Left Hand	20	7-A-125	7170-3X	—**HM	5-P-1197	Right Hand	20
630*FN	5-P-1070	Left Hand	26	7-A-300	7170-4X	—**HR	5-P-1201	Right Hand	26
630*HY	5-P-1237	Left Hand	26	7-A-125	7170-1X	—**JB	5-P-1244	Right Hand	26
630*IT	KIT ADAPTER	—	—	—	—	—	—	—	—
630*JK	5-P-1261	Left Hand	24	7-A-187	7170-3X	—**JL	5-P-1262	Right Hand	24
630*JU	5-P-1316	Left Hand	25	7-A-200	7170-4X	—**KA	5-P-1318	Right Hand	25
630*JW	5-P-1319	Left Hand	23	7-A-093	7170-3X	—**KB	5-P-1321	Right Hand	23

Options

645 Gear Chart

Adapter Input Gear				Mounting Information PTO to Adapter		PTO Gear (Packaged Loose w/Adapter)			
Model No.	Part No.	Helix Angle	No. Teeth	Spacer Designator	Stud Kit	PTO Pitch	Part No.	Helix Angle	No. Teeth
645*AH	5-P-1004	Spur	22	7-A-140	7170-3X	—**AH	5-P-1004	Spur	22
645*AR	5-P-1008	Left Hand	21	7-A-187	7170-3X	—**GY	5-P-1184	Right Hand	21
645*BG	5-P-1015	Left Hand	23	7-A-140	7170-3X	—**HB	5-P-1187	Right Hand	23
645*BQ	5-P-1023	Left Hand	25	7-A-200	7170-4X	—**BP	5-P-1022	Right Hand	26
645*DA	5-P-1037	Spur	23	—	—	—**DA	5-P-1037	Spur	23
645*DU	5-P-1050	Left Hand	28	7-A-240	7170-4X	—**HH	5-P-1193	Right Hand	28
645*ES	5-P-1059	Left Hand	22	7-A-062	—	—**HL	5-P-1196	Right Hand	22
645*EV	5-P-1060	Spur	40	7-A-300	7170-4X	—**EV	5-P-1060	Spur	40
645*EW	5-P-1061	Left Hand	20	7-A-125	7170-3X	—**HM	5-P-1197	Right Hand	20
645*FN	5-P-1070	Left Hand	26	7-A-300	7170-4X	—**HR	5-P-1201	Right Hand	26
645*HY	5-P-1237	Left Hand	26	7-A-125	328170-94X	—**JB	5-P-1244	Right Hand	26
645*JK	5-P-1261	Left Hand	24	7-A-187	7170-3X	—**JL	5-P-1262	Right Hand	24
645*JU	5-P-1316	Left Hand	25	7-A-200	7170-4X	—**KA	5-P-1318	Right Hand	25
645*JW	5-P-1319	Left Hand	23	7-A-093	7170-3X	—**KB	5-P-1321	Right Hand	23
645*IT	KIT ADAPTER	—	—	—	—	—	—	—	—

When these adapters or plates appear on a transmission application page or come with the PTO assembly, they MUST be used. There are no substitutes.

As with other Chelsea PTOs, these geared adapters will change PTO rotation, but they will not change PTO speed.

Geared Adapters and Plates for Import Transmissions		
Transmission	Adapter Gear or Plate General Description	A Body Thickness or Degree of Angularity
Mitsubishi		
328997X (1)	M4, M5, M6, M5S5 Models FH100 & FK415, M6S5 Models FK455 & FM555, M6S6 Model FM555	45°
42-P-211 (2)	MO35S5 & MO38S6 (included with 447C PTO)	1.470"
Nissan		
42-P-190 (2)	MLS-61A, MLS-61B UD3000SD (included with 447A PTO)	1.329"

(1) This geared adapter adapts a non-standard opening on the transmission to a standard 6-Bolt opening. It will move the PTO straight out from the transmission by approximately the amount indicated in column A.

(2) This is an adapter plate that converts the non-standard opening on the transmission to a standard 6-Bolt opening.

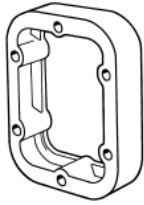

The lubricant in the transmission also lubricates the PTO. Therefore, one or more gaskets (as required) must always be used between the metal surfaces of the Power Take-Off, the adapter gear assembly, the adapter plate, and the filler block(s).

Options

Mounting Gasket Kits			
Gasket Kit Part Number	Quantity.	Gasket Part Number	Application
328570-1X	25	35-P-15-1 35-P-15-2	Standard 8 Bolt
328570-2X	10	35-P-15-1	Standard 8 Bolt
328570-3X	100	35-P-9-1	Standard 6 Bolt
328570-4X	100	35-P-9-2	Standard 6 Bolt
328570-6X	50	35-P-9-2	Standard 6 Bolt
329062-3X	25	35-P-56 329015X	328888X, 329011X, & Adapters
329062-5X	25	35-P-63-1 35-P-63-2	328957X Adapter
329062-7X	25	35-P-65	328962X & 328993X Adapters
329062-8X	25	35-P-67	328983X Adapter
329062-9X	25	35-P-68-1 35-P-68-2	328985X Adapter
329062-10X	25	35-P-72	328997X Adapter
329062-11X	25	35-P-73	329000-1X Adapter

Special Mounting Gaskets	
Gasket Part Number	Application
35-P-41	272 X AAJ
35-P-69	272M Series Adapter Plate Mounting
35-P-74	267, 269, 280, 859, 870/877, 890/897
35-P-8	435, 437
35-P-84	231/271 Series PTO Mounting
22-P-124	249 Series (All)
28-P-397	210 Series

Cable Controls Stainless Steel Vinyl Covered Wire		
Assembly (Wire & Knob)	Wire Only	Knob Only
328346-10X*	378441-10 (10 Foot Length)	378502
328346-15X**	378441-15 (15 Foot Length)	378502
328346-20X	378441-20 (20 Foot Length)	378502
328346-25X	378441-25 (25 Foot Length)	378502
328346-30X	378441-30 (30 Foot Length)	378502

*This 10 foot cable and knob are standard on the following Chelsea PTOs with a W shifter type: 221, 260, 290, 352, 435, 442, 447, and 489.

** The 15 foot cable is standard on the 2442.

Gasket and Seal Kits				
PTO Series Part Number	Gasket and Seal Kit	Shifter Cover Seal Kit Part Number		
		Cable Control	Lever Control	Air Control
210	330009-1X			
221	328356-13X			
249/249F	329248-1X			
249V	329248-6X			
267	329337-2X			
272/282	329071-62X			
280	329071-62X (All Except BA)			
290	328356-67X			328356-71X
442, 447, 660	328356-67X	328356-15X	328356-26X	328356-17X
	328356-69X (A & C Ratio)			
489, 680	328356-50X	328356-15X	328356-26X	328356-17X
	328356-69X (A & C Ratio)			
823 Standard Output (AB, AC & XV)			328356-2X	328356-2X
823 Direct Mount Output (XS & XU)			328356-4X	328356-4X
863	328356-39X			
870	329071-55X (XV, RS Output)			
	329071-55X (RZ, RY Output)			
870XL (All Outputs)	329929-1X			
877XL (All Outputs)	329929-3X			
880	Standard Output		328356-53X	328356-54X
	Pump Output	328356-51X 328356-52X	328356-53X	328356-54X
890	329071-46X (XS, XK, AF, AZ)			
	329071-47X (XY)			
901	328267X			328356-40X
912	328356-65X		328356-62X	
	328356-63X			
	328356-64X			
2442	Top Unit	328356-15X		
	Bottom Unit	328356-13X	328356-15X	328356-26X 328356-17X

The kits shown below are included for standard applications. Many applications require special stud kits. These are called out on the application pages in the Chelsea HY25-3000/US catalog. Therefore, always consult the application pages in the Chelsea HY25-3000/US before specifying stud kits.

Options

Mounting Kits				
Series	Standard (X*)	Deep Mount (Z*)	Metric (G*)	Miscellaneous
210			8000-50X	(F*) 8000-50X (G*) 8000-50X (X*) 8000-50X
221	328170-1X	328170-26X		(R*) 328170-155X
249			8000-21X	(F) 8000-21X
249V			8000-45X	(F) 8000-45X
252			7170-102X (Allison)	7170-121X (RAM/Aisin)
267	7170-86X			(J*) 7170-87X (M*) 7170-127X
272	7170-129X	7170-131X	7170-72X	(A*, D*, R*) 7170-128X (E*) 7170-129X (N*) 7170-130X
280			7170-86X (FJ) 7170-117X (KV)	
282	328170-200X		328170-201X	(E*) 328170-200X
290	328170-76X		7170-72X	
340	328170-94X	328170-95X	7170-72X	(S*) 328170-95X
348	328170-209X	328170-209X	7170-120X	
352	328170-76X	328170-94X	7170-72X	
442	328170-76X	328170-77X	7170-72X	
447	328170-76X	328170-77X	7170-72X	
489	328170-200X	328170-200X	328170-201X	
541	328794-50X			
660	328170-76X	328170-77X	7170-72X	(D*) 7170-72X
680	328170-200X	328170-200X	7170-68X	
823	328170-8X		328170-185X	
852	328170-8X			
863	328170-8X		328170-185X	
870	7170-86X (FJ, LN), 7170-117X (KV)			
870XL			7170-86X	†
877	7170-86X (FJ, LN), 7170-117X (KV)			
877XL			7170-86X	†
880	328170-192X	328170-195X	328170-201X	
885	328170-192X			
890	7170-86X			
892	7170-86X			
897	7170-86X			
899	7170-86X			
626	328170-76X		7170-72X	7170-72X (626DJA*)
628	328170-209X	328170-209X	328170-201X	
630	328170-76X	328170-77X	7170-78X	7170-72X (630DJA*)
645	328170-76X	328170-77X	7170-78X	7170-72X (645DJA*)
329138X,-1X	328170-95X		7170-72X	
328481X	328170-128X			
328481G			8000-14X	
328564X	328170-127X			
328564G			8000-15X	

* This letter is the Mounting Type Designator found in the Model Number — Example: **442XSAHX-A3XK**

† See Model Configuration for all Mounting Option Codes

890 Family Bracket Kits

Model	Arr.	Bracket Kit and Hose Part Number	Mounting PTO Code	Bracket Kit and Hose Description	Bracket	Pressure Hose
3000 Series Side/Side Openings						
890/897	5	329897-1X	L	Left side	50-P-60	329130-5X
890/897	5	329897-2X	R	Right side w/ or w/o cooler	50-P-61	329130-11X
890/897	5	329897-24X	Y	Right side clocked right	50-P-156	329130-11X
890/897	3	329897-13X	N	Left side w/ cooler	50-P-151	329130-5X
890/897	5	329897-12X	M	Left side w/ retarder	50-P-146	329130-5X

3000 Series Side/Top Openings						
890/897	5	329897-4X	E	Left side	50-P-72	329130-5X
890/897	5	329897-5X	T	Right top side w/ or w/o cooler	50-P-67	329075-2X
890/897	5	329897-14X	F	Left side w/ retarder	50-P-129	329130-5X

4000 Series 6-Speed						
890/897	5	329897-3X	H	Left side	50-P-62	329130-4X
890/897	5	329897-6X	U	Right top side w/ or w/o cooler	50-P-73	329075-2X
890/897	3	329897-7X	C	Left side w/ cooler	50-P-74	329130-4X
890/897	5	329897-19X	P	Left side w/ retarder	50-P-130	329130-4X
890/897	3	329897-10X	J	Left side w/ retarder	50-P-126	329130-4X
890/897	5	329897-11X	K	Right top side w/ retarder	50-P-127	329075-2X

4700/4800 Series 7-Speed						
892/899	5	329897-3X	H	Left side	50-P-62	329130-4X
892/899	5	329897-6X	U	Right top side w/ or w/o cooler	50-P-73	329075-2X
892/899	3	329897-7X	C	Left side w/ cooler	50-P-74	329130-4X
892/899	5	329897-19X	P	Left side w/ retarder	50-P-130	329130-4X
892/899	3	329897-10X	J	Left side w/ retarder	50-P-126	329130-4X
892/899	5	329897-11X	K	Right top side w/ retarder	50-P-127	329075-2X

870XL Family Bracket Kits

870XL	All	329926X	-	-	50-P-169 (UC)	-
870XL	All	329926X	-	-	50-P-170 (LC)	-

Arr. = Assembly Arrangement
UC = Upper Clamp
LC = Lower Clamp

NOTE: All kits include capscrews for mounting the bracket to the transmission and PTO.

PTO/Dump Pump Combo Valve:

This shift option is designed to make PTO/dump pump air shift applications safer and easier. The compact design features a safety interlock to prevent accidental PTO engagement, automatic PTO disengagement when in the lower position to prevent the PTO from being accidentally left in gear, and controlled lowering (feathering) for smooth dump body descent. The controls are easily operated, even when the driver is wearing gloves. It is ideal for use in systems with Chelsea dump pumps, wet line reservoirs, and PTOs.



Options

Features							
Part Number	PTO Kick Out	Spring Return to Neutral on Dump Valve Control	Manual Return to Neutral on Dump Valve	Safety Lock on PTO	Detent Lock on Neutral	Smooth Descent	LED Light
Air Shift PTOs							
329214X & -2X	x	x		x	x	x	x
329316X & -2X			x	x	x	x	x
329358X	x		x	x	x	x	x
Hydraulic Shift PTOs							
329214-1X	x	x		x	x	x	x
329216-1X			x	x	x	x	x

Order Code	PTO Models	Chelsea Part No.	Installation Kit	Description
Air Shift PTOs				
S	442 & 489	329214X	328388-65X	Feathering & PTO Kick-out in Lower position Spring return to Neutral in Raise position
T	442 & 489	329316X	328388-72X	Feathering & NO PTO Kick-out in Lower position Detent in Raise position
U	442 & 489	329358X	328388-79X	Feathering & PTO Kick-out in Lower position Detent in Raise position
Hydraulic Shift PTOs				
S	280	329214-1X	328388-85X	Hoist/PTO control valve that allows a smooth descent of the body in the lower position. Features automatic disengagement of the PTO in lower. Lever on the control valve returns to neutral from the raise position when released (dead man's handle).
S	272	329214-1X	328388-87X	
T	280	329216-1X	328388-86X	Hoist/PTO control valve that allows a smooth descent of the body in the lower position. Requires manual disengagement of the PTO in lower.
T	272	329216-1X	328388-88X	

General Specifications						
Pump	Gear Width	GPM US at 1000 RPM	Cubic Inch Displacement	Horsepower Input (at 2000 PSI) 1000 RPM	Maximum Pressure	Maximum Speed
C101/102-20	2.000"	22	5.1	25.6	2500	2400 RPM
C101/102-25	2.500"	27.6	6.38	31	2500	2500 RPM
G101/102-1-0.7	.750"	6.4	1.48	6.2	2500	2500 RPM
G101/102-1-1.5	1.500"	12.8	2.96	13.7	2500	2500 RPM
G101/102-1-2.0	2.000"	17	3.94	18.8	2500	2500 RPM

All data based on SAE 10W oil at 150°F. Minimum pump speed at pressure is 800 RPM. US Gallons displacements are theoretical. They will vary depending on speed, pressure, and temperature.

Three-Line Installation (for intermittent or continuous operation)

With the internal sleeve installed in the pump and three-line installation, two advantages are provided:

- A. Minimizes the possibility of overheating
- B. The filter keeps the system clean for prolonged trouble-free operation.*

*If filter is used, check valve must be added to prevent backflushing filter.

Dump Pump 3-Line System Shown in the Neutral Mode (Continuous operation)

In the neutral mode, all the flow goes across the spool to the Return Port and back to tank because the internal by-pass passage is blocked by the sleeve in the inlet port. Any pressure higher than the setting of the relief valve is relieved internally through the by-pass to the Return Port.

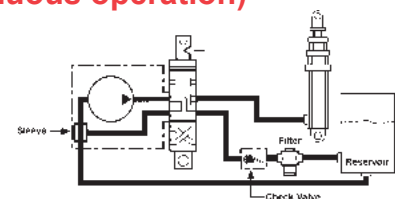

Two-Line Installation (for intermittent operation only)

With the internal sleeve removed a two-line hook-up can be arranged, however the oil circulates internally (within the pump). Continuous operation may result in overheating and damage to the pump.

Dump Pump 2-Line System Shown in the Neutral Mode

In the neutral mode, the flow goes across the spool to the Return Port and the integral by-pass passages. Because the Return Port is plugged, and the pressure drop through the by-pass is less than what is required to activate the cylinder, all flow goes through the by-pass back to the inlet side of the pump. Any pressure higher than the setting of the relief valve is relieved internally through the by-pass, back to the inlet port.

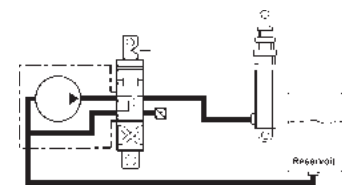

These pumps are shipped with an internal sleeve for three-line (continuous duty, filtered) systems. For two-line systems for intermittent duty cycles*, discard the sleeve.

*Pump/PTO operates 5 out of every 15 minutes. Note that three-line systems are always recommended to prolong the trouble-free operation of the hydraulic system.

NOTES

Options

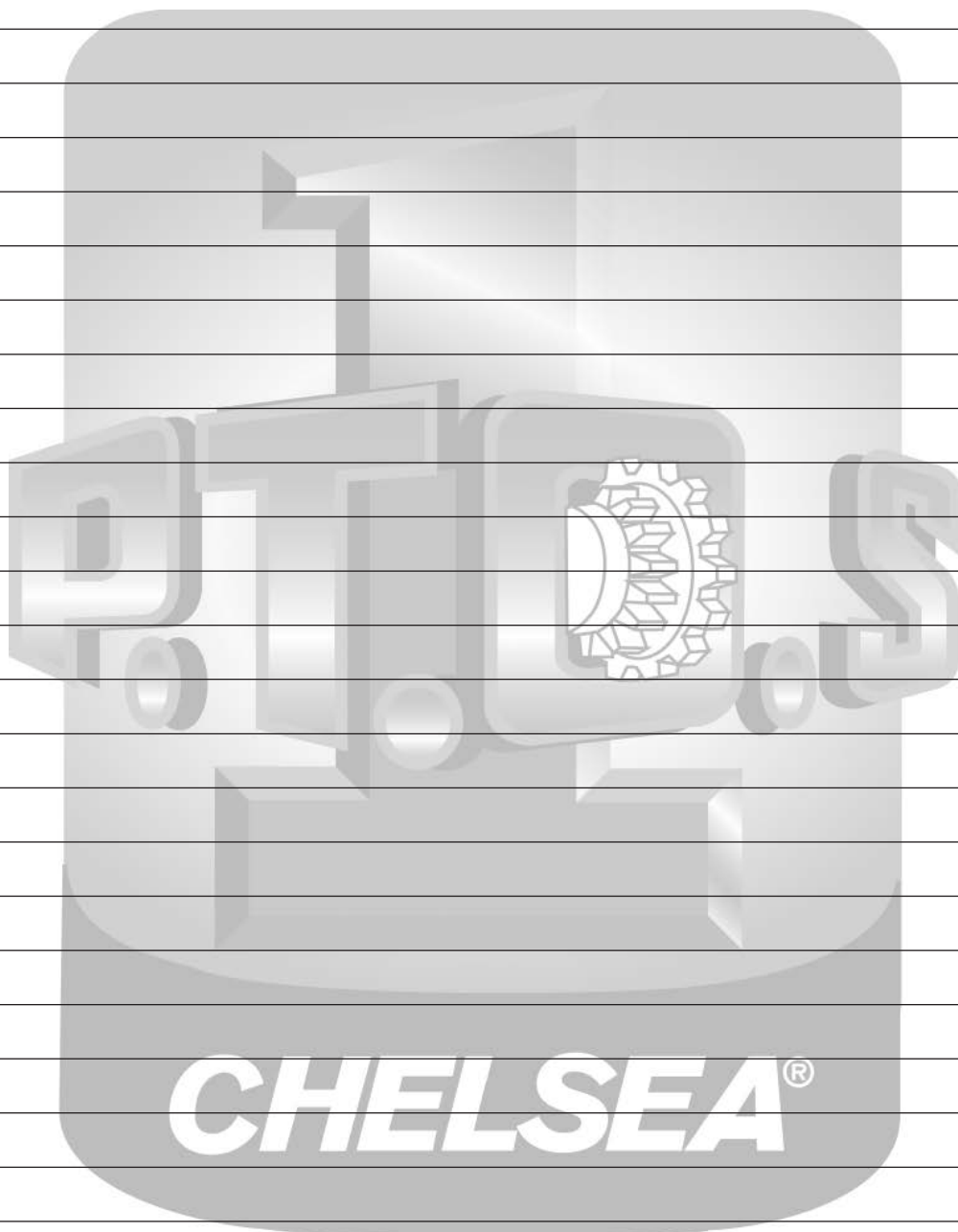

FLANGE DRAWINGS

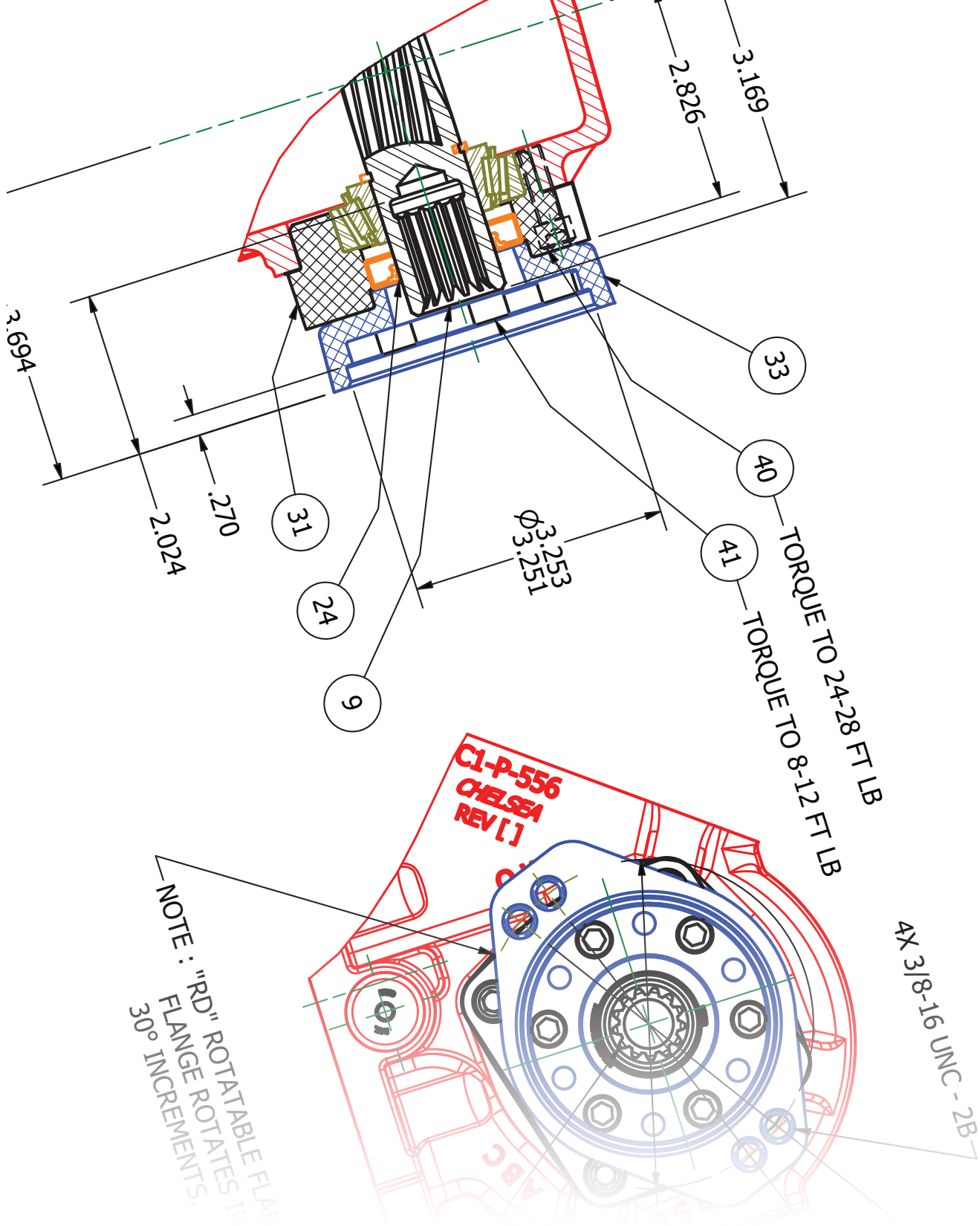

Output Option Code	3.1 thru 3.47
AB	3.1 thru 3.2
AC	3.2 thru 3.4
AD	3.4 thru 3.5
AF	3.5 thru 3.6
AK	3.6
AZ	3.6 thru 3.7
BB	3.7
BC, BD	3.8
BV	3.9
CF	3.10
CK, CS	3.10
CZ, DA	3.11
G, GA	3.11 thru 3.12
GB, GF	3.12
GH, GK, GQ,	3.13
GR, GS	3.14
GU, GY, GZ	3.15
RA	3.16
RB	3.16 thru 3.17
RC, RD	3.17
RE	3.18
RF	3.18 thru 3.19
RJ	3.20
RK	3.20 thru 3.21
RS	3.21 thru 3.22
RY	3.22 thru 3.23
RZ	3.24
SB	3.25
SC	3.25 thru 3.26
SD	3.26 thru 3.27
SQ	3.27
SV, TF	3.28
TK, TS, TV	3.29
TY, TZ, XB	3.30
XD	3.31 thru 3.32
XE	3.33
XK	3.33 thru 3.35
XP	3.36
XQ	3.36
XR	3.37
XS	3.38 thru 3.39
XU	3.40
XV	3.41 thru 3.45
XX	3.45
XY	3.45 thru 3.47
ZS, 21-P-525	3.47

Flanges

Option Code – AB	
Type	Remote Mount
Shaft	DIN 120 Flange
PTO Series: 272, †272U, 282	

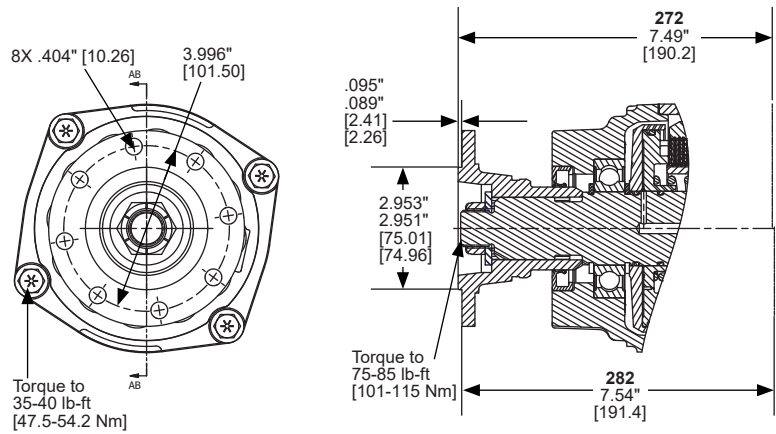

† Coming Soon

Option Code – AB	
Type	Remote Mount
Shaft	DIN 120 Flange
PTO Series: 280, 287	

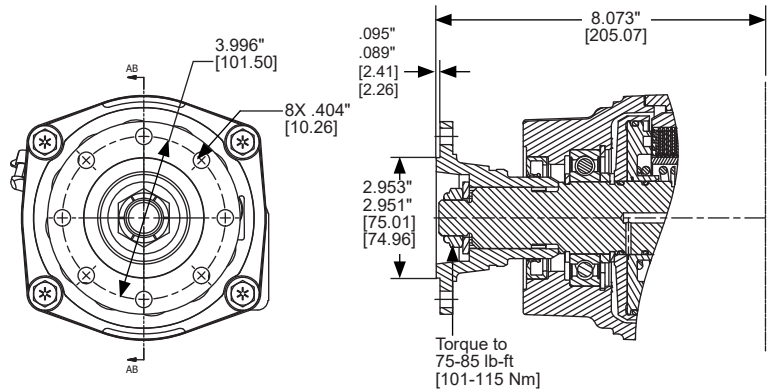

Flanges

Option Code – AB	
Type	Remote Mount
Shaft	DIN 120 Flange
PTO Series: 823, 823 DT12	

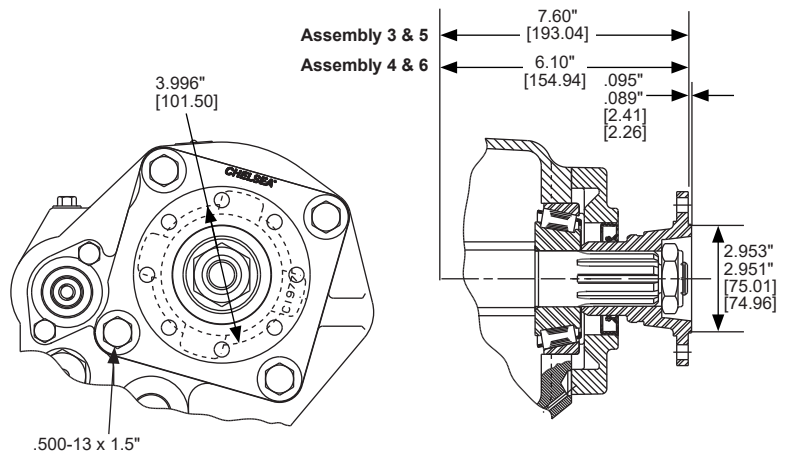

NOTE: PUMP INSTALLATION PRECAUTIONS

Pump support brackets may be required - see General Safety information section for pump support bracket requirements. Also remember to pack the female PTO shaft with grease before installing the pump to the PTO.

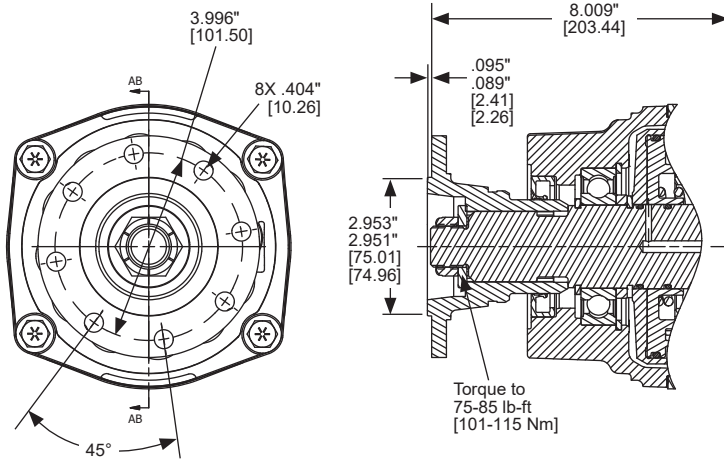

Option Code – AB	
Type	Remote Mount
Shaft	DIN 120 Flange
PTO Series: 870, 877	

Flanges

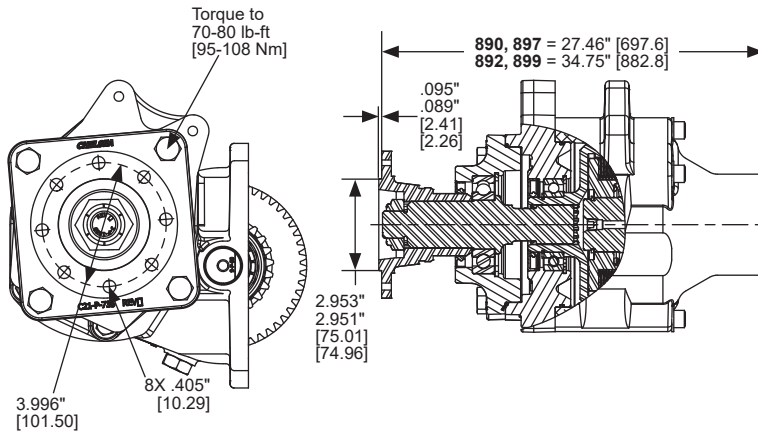

Option Code – AB	
Type	Remote Mount
Shaft	DIN 120 Companion Flange
PTO Series: 890, 892, 897, 899	

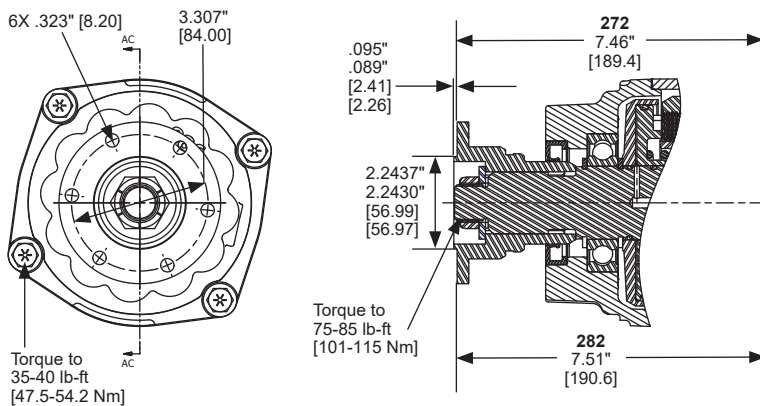

Option Code – AC	
Type	Remote Mount
Shaft	DIN 100 Flange
PTO Series: 272, †272U, 282	

† Coming Soon

NOTE: PUMP INSTALLATION PRECAUTIONS

Pump support brackets may be required - see General Safety information section for pump support bracket requirements. Also remember to pack the female PTO shaft with grease before installing the pump to the PTO.

Option Code – AC	
Type	Remote Mount
Shaft	DIN 100 Flange
PTO Series: 280, 287	

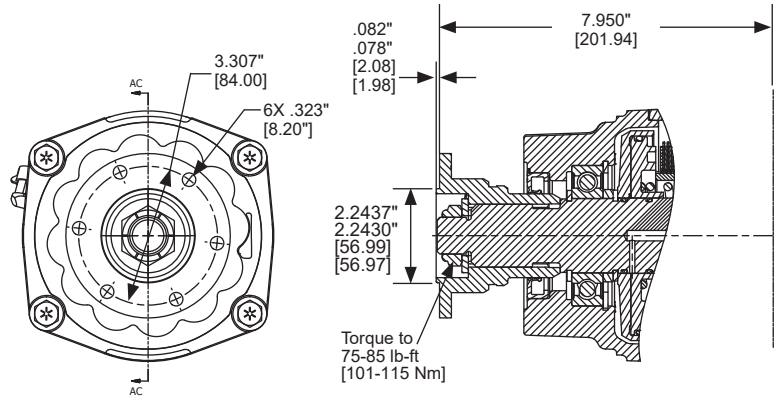

Option Code – AC	
Type	Remote Mount
Shaft	DIN 100 Flange
PTO Series: 823, 823 DT12	

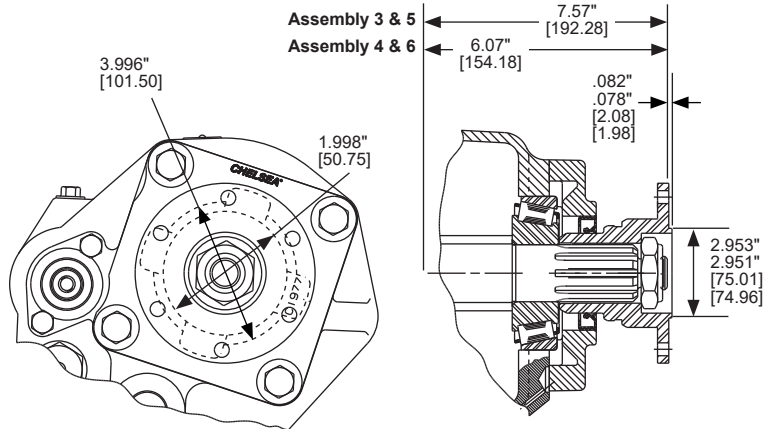

Option Code – AC	
Type	Remote Mount
Shaft	DIN 100 Flange
PTO Series: 870, 877	

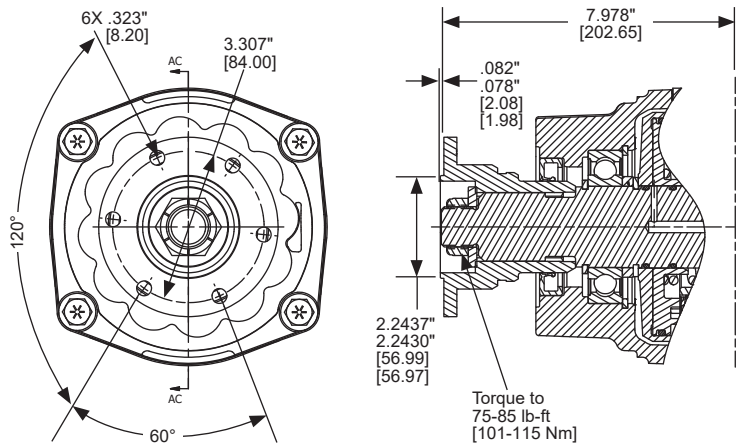

Flanges

NOTE: PUMP INSTALLATION PRECAUTIONS

Pump support brackets may be required - see General Safety information section for pump support bracket requirements. Also remember to pack the female PTO shaft with grease before installing the pump to the PTO.

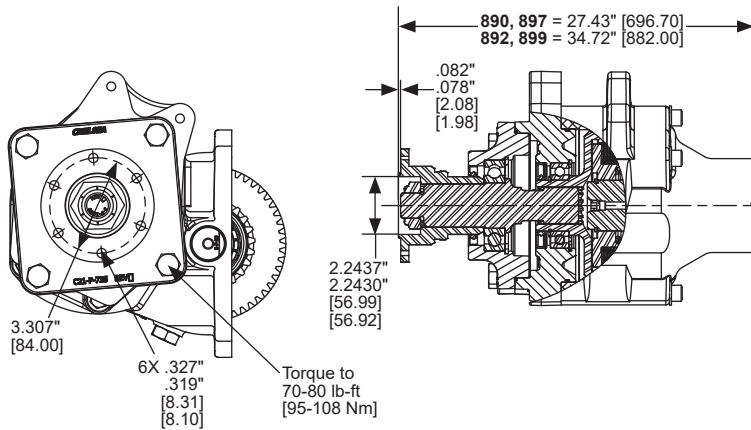

Option Code – AC	
Type	Remote Mount
Shaft	DIN 100 Flange
PTO Series: 890, 892, 897, 899	

Flanges

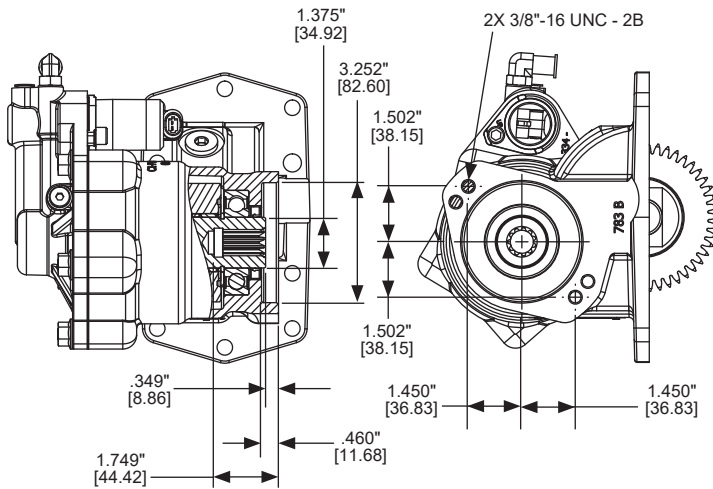

Option Code – AD	
Type	Direct Mount
Shaft	SAE 19-4 (3/4" - 11T)
Flange	SAE A 2-Bolt
PTO Series: 210	

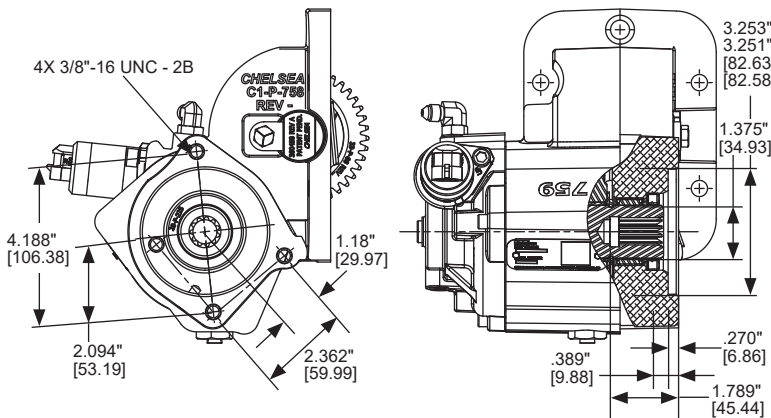

Option Code – AD	
Type	Direct Mount
Shaft	SAE 19-4 (3/4" - 11T)
Flange	SAE A 2-Bolt
PTO Series: 249	

NOTE: PUMP INSTALLATION PRECAUTIONS

Pump support brackets may be required - see General Safety information section for pump support bracket requirements. Also remember to pack the female PTO shaft with grease before installing the pump to the PTO.

Option Code – AD	
Type	Direct Mount
Shaft	SAE AH (3/4" - 11T)
Flange	SAE A 2-Bolt
PTO Series: 252	

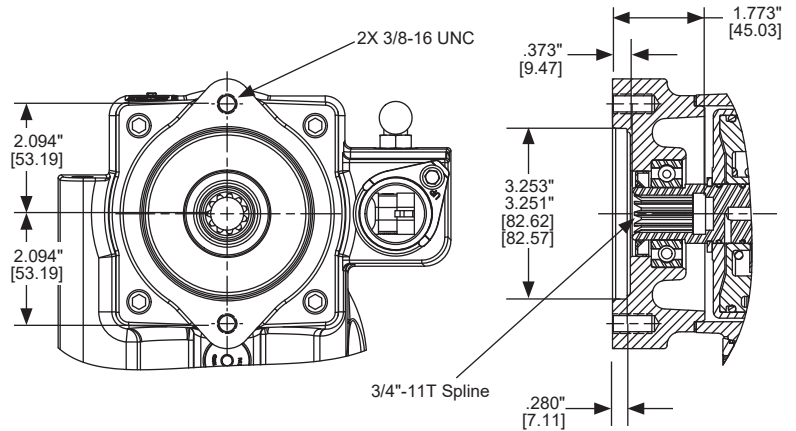

Option Code – AF	
Type	Direct Mount
Shaft	SAE BB (1" - 15T)
Flange	SAE B 2 or 4-Bolt
PTO Series: 221, 267, 442, 447, 489, 660, 680, 2442	

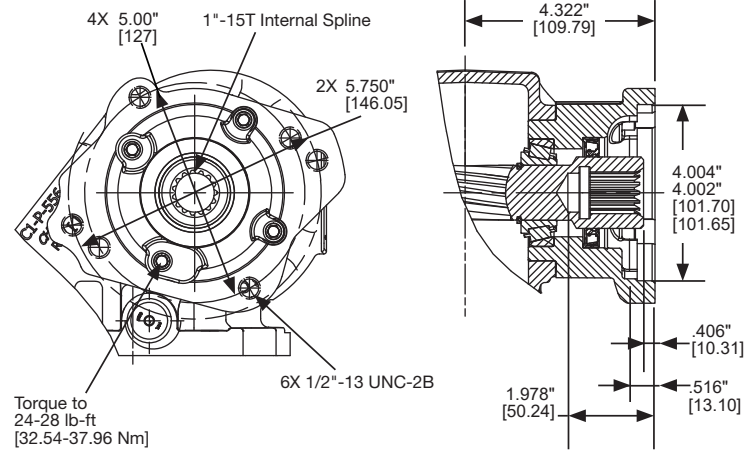

Option Code – AF	
Type	Direct Mount
Shaft	SAE BB (1" - 15T)
Flange	SAE B 2 or 4-Bolt
PTO Series: 880, 880 DT12	

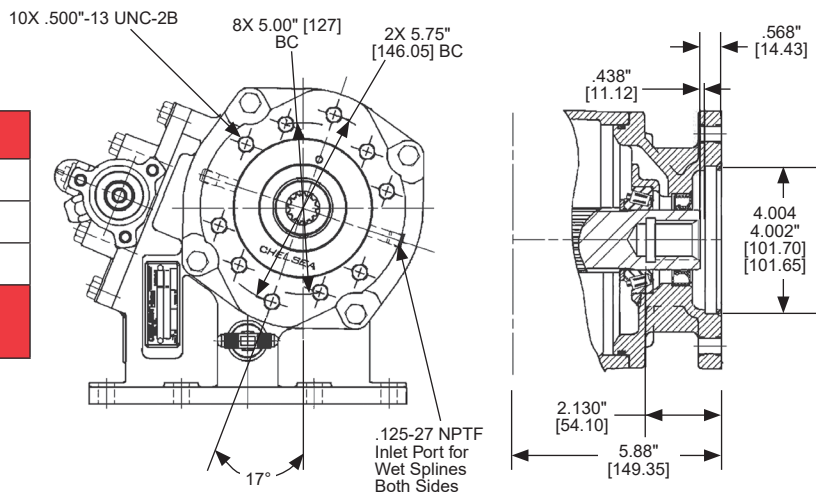

Flanges

NOTE: PUMP INSTALLATION PRECAUTIONS

Pump support brackets may be required - see General Safety information section for pump support bracket requirements. Also remember to pack the female PTO shaft with grease before installing the pump to the PTO.

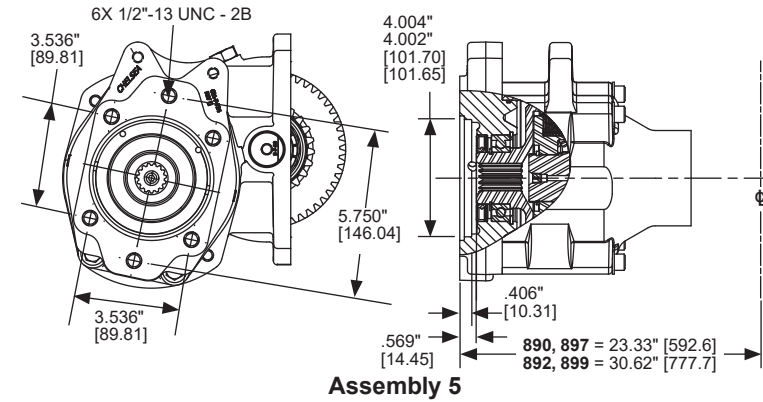

Option Code – AF	
Type	Direct Mount
Shaft	SAE BB (1" - 15T)
Flange	SAE B 2 or 4-Bolt
PTO Series: 890, 892, 897, 899	

Flanges

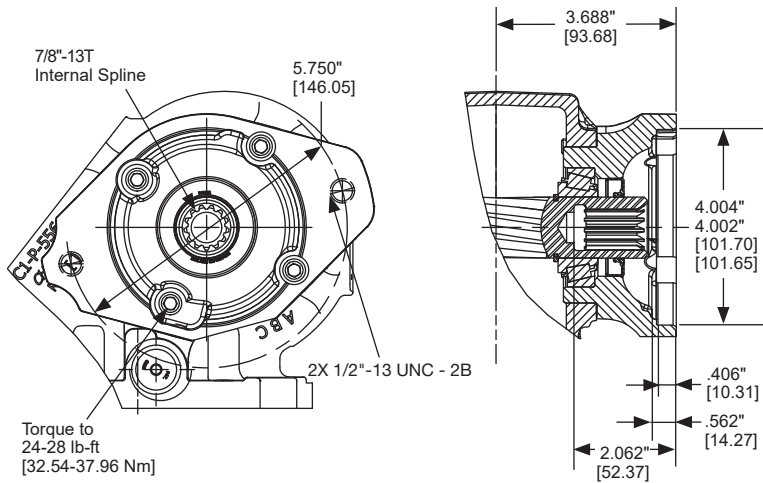

Option Code – AK	
Type	Direct Mount
Shaft	SAE B (7/8" - 13T)
Flange	SAE B 2-Bolt
PTO Series: 221, 267, 442, 447, 489, 660, 680, 2442	

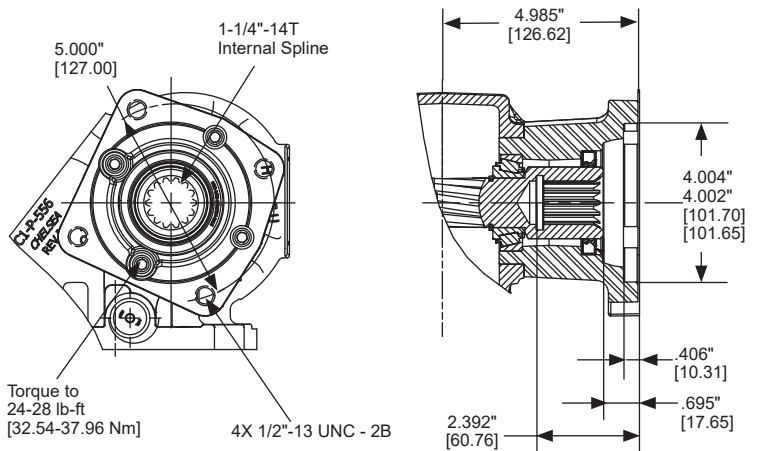

Option Code – AZ	
Type	Direct Mount
Shaft	SAE C (1-1/4" - 14T)
Flange	SAE B 4-Bolt
PTO Series: 221, 267, 442, 447, 489, 660, 680, 2442	

* Recommended Grease: Texaco Coupling Grease, Code 1912 or Equivalent

NOTE: PUMP INSTALLATION PRECAUTIONS

Pump support brackets may be required - see General Safety information section for pump support bracket requirements. Also remember to pack the female PTO shaft with grease before installing the pump to the PTO.

Option Code – AZ	
Type	Direct Mount
Shaft	SAE C (1-1/4" - 14T)
Flange	SAE B 2 or 4-Bolt
PTO Series: 880, 880 DT12	

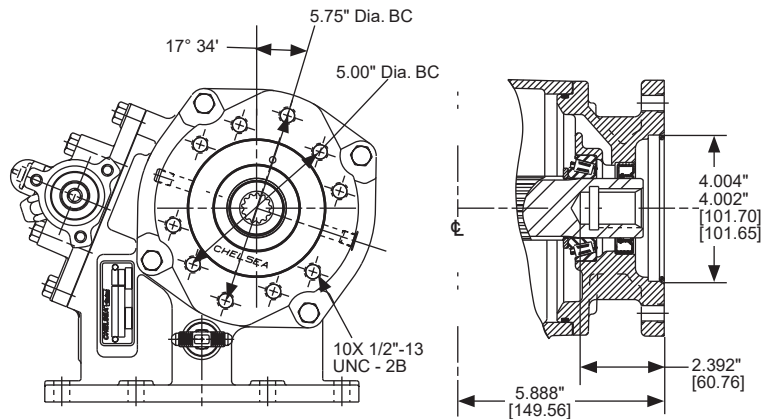

Option Code – AZ	
Type	Direct Mount
Shaft	SAE C (1-1/4" - 14T)
Flange	SAE B 2 or 4-Bolt
PTO Series: 890, 892, 897, 899	

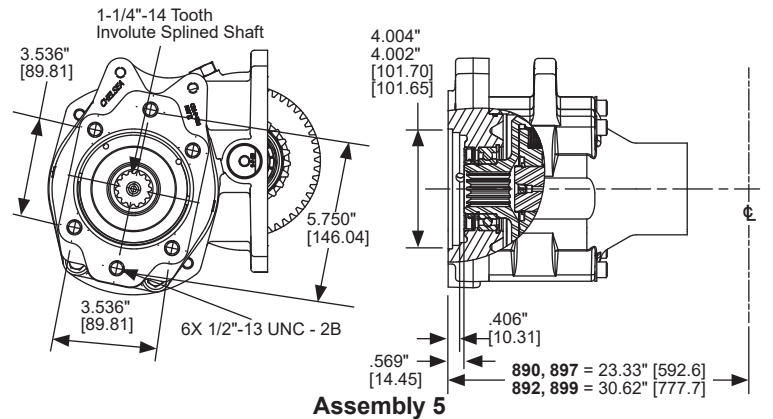

Assembly 5

Option Code – BB	
Type	Remote Mount
Shaft	DIN 120 Flange w/ Shaft Brake
PTO Series: 870	

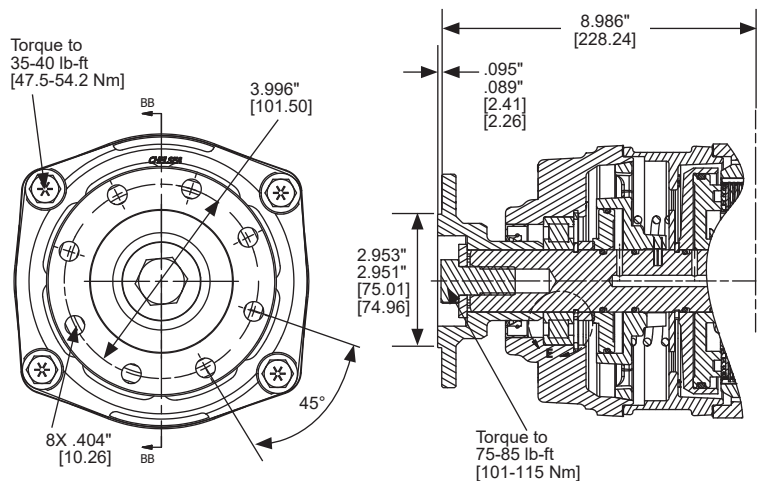

* Recommended Grease: Texaco Coupling Grease, Code 1912 or Equivalent

NOTE: PUMP INSTALLATION PRECAUTIONS

Pump support brackets may be required - see General Safety information section for pump support bracket requirements. Also remember to pack the female PTO shaft with grease before installing the pump to the PTO.

Flanges

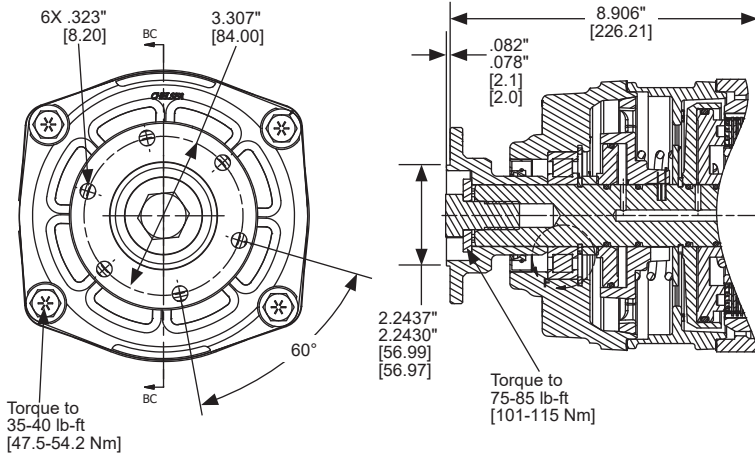

Option Code – BC	
Type	Remote Mount
Shaft	DIN 100 Flange w/ Shaft Brake
PTO Series: 870	

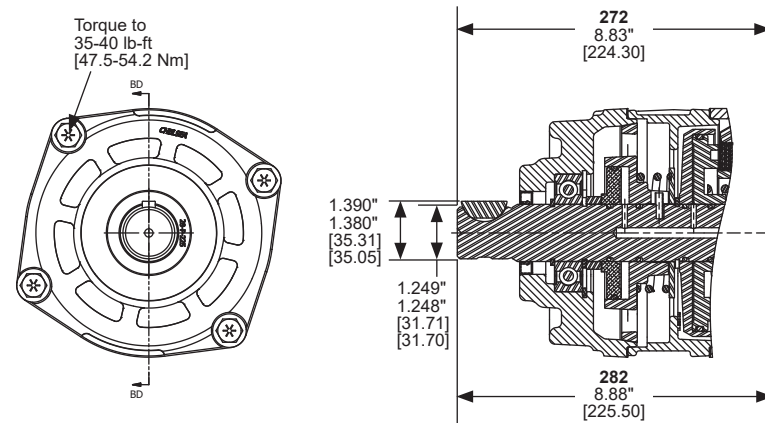

Option Code – BD	
Type	Remote Mount
Shaft	1-1/4" Keyed w/ Shaft Brake
PTO Series: 272, 282	

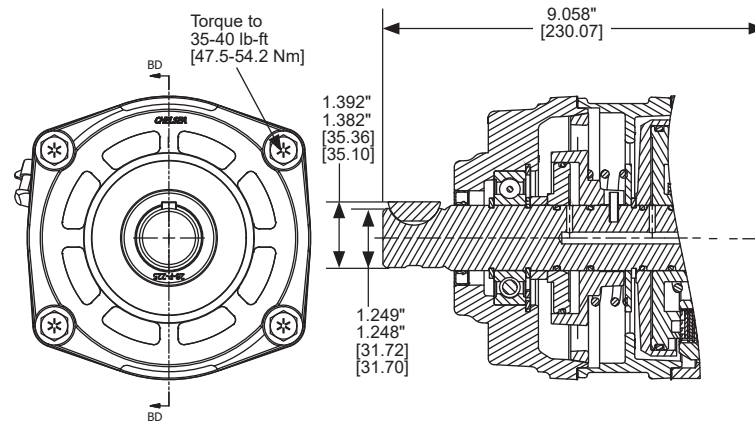

Option Code – BD	
Type	Remote Mount
Shaft	1-1/4" Rd. Keyed w/ Shaft Brake
PTO Series: 280	

NOTE: PUMP INSTALLATION PRECAUTIONS

Pump support brackets may be required - see General Safety information section for pump support bracket requirements. Also remember to pack the female PTO shaft with grease before installing the pump to the PTO.

Option Code – BV	
Type	Remote Mount
Shaft	1410 Companion Flange w/ Shaft Brake
PTO Series: 272, 282	

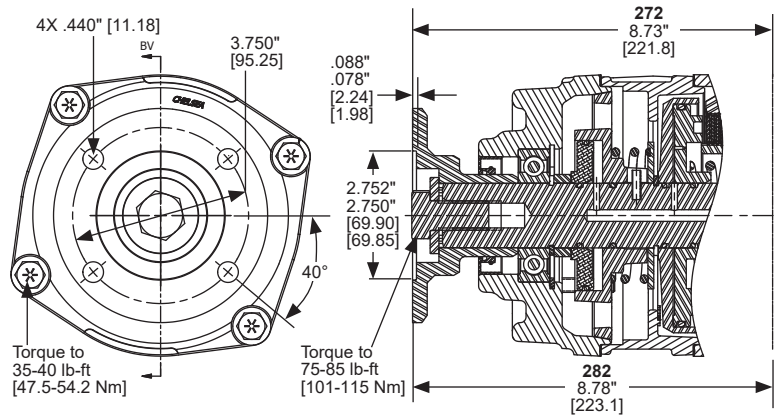

Option Code – BV	
Type	Remote Mount
Shaft	1410 Companion Flange w/ Shaft Brake
PTO Series: 280	

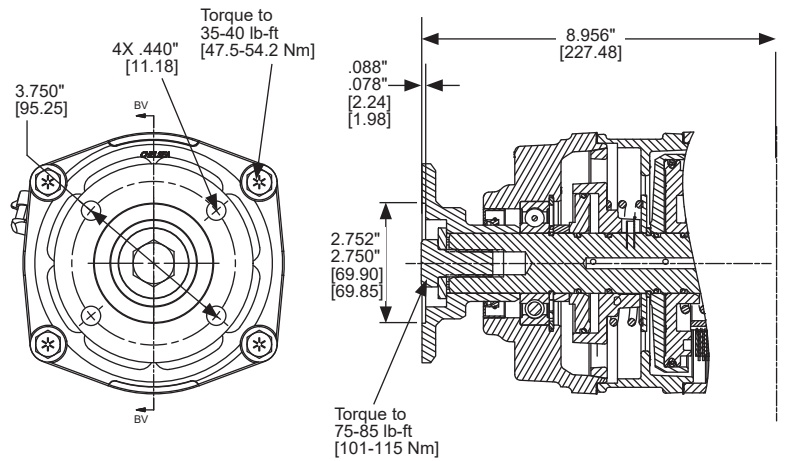

Option Code – BV	
Type	Remote Mount
Shaft	1410 Companion Flange w/ Shaft Brake
PTO Series: 870	

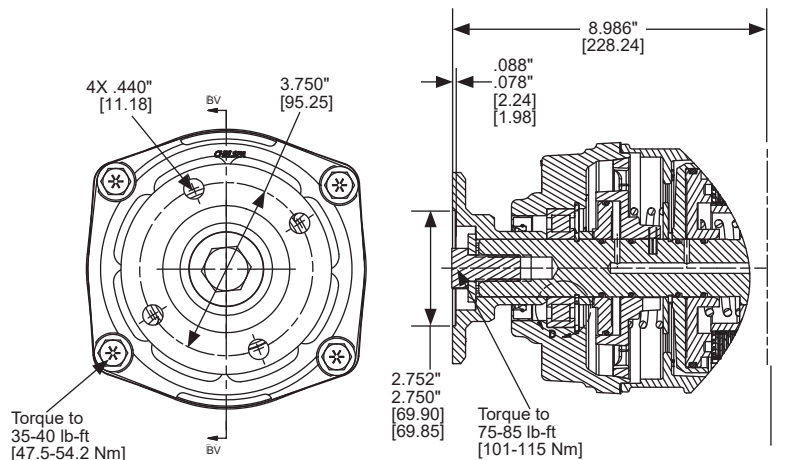

Flanges

NOTE: PUMP INSTALLATION PRECAUTIONS

Pump support brackets may be required - see General Safety information section for pump support bracket requirements. Also remember to pack the female PTO shaft with grease before installing the pump to the PTO.

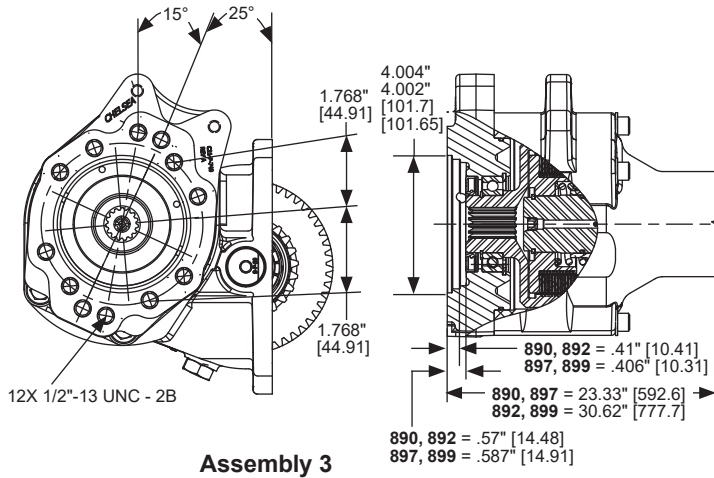

Option Code – CF	
Type	Direct Mount
Shaft	SAE BB (1" - 15T)
Flange	SAE B 2 or 4-Bolt
PTO Series: 890, 892, 897, 899	

Flanges

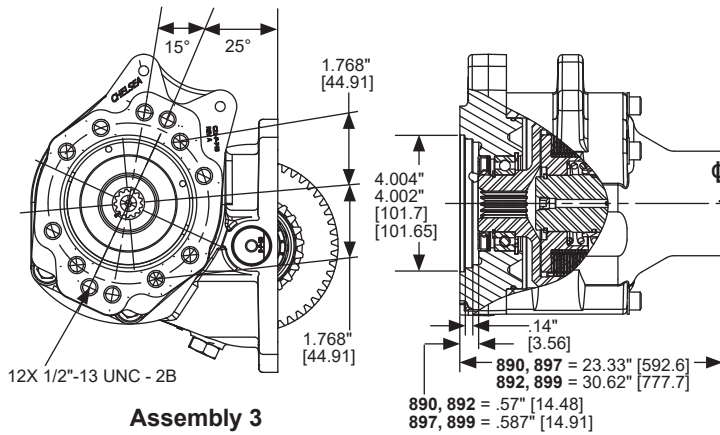

Option Code – CK	
Type	Direct Mount
Shaft	SAE B (7/8" - 13T)
Flange	SAE B 2 or 4-Bolt
PTO Series: 890, 892, 897, 899	

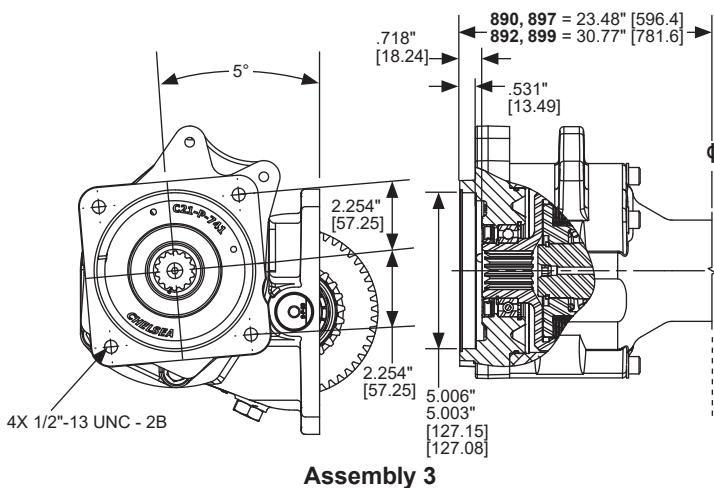

Option Code – CS	
Type	Direct Mount
Shaft	SAE C (1-1/4" - 14T)
Flange	SAE C 4-Bolt
PTO Series: 890, 892, 897, 899	

NOTE: PUMP INSTALLATION PRECAUTIONS

Pump support brackets may be required - see General Safety information section for pump support bracket requirements. Also remember to pack the female PTO shaft with grease before installing the pump to the PTO.

Option Code – CZ	
Type	Direct Mount
Shaft	SAE C (1-1/4" - 14T)
Flange	SAE B 2 or 4-Bolt
PTO Series: 890, 892, 897, 899	

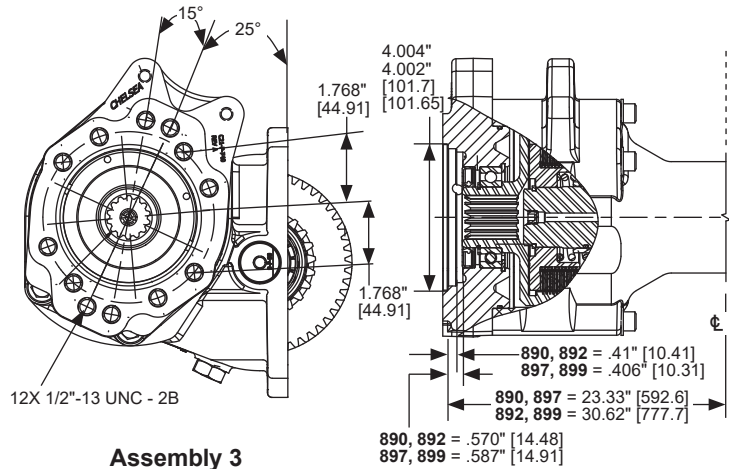

Option Code – DA	
Type	Direct Mount
Shaft	SAE D (1-3/4" - 13T)
Flange	SAE D 4-Bolt
PTO Series: 890, 892, 897, 899	

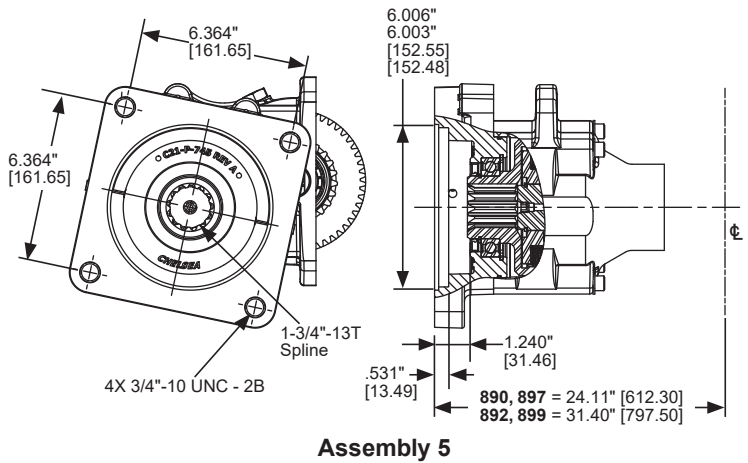

Flanges

Option Code – G	
Type	Direct Mount
NOTE	All greaseable output assemblies have this closed bearing cap configuration.
PTO Series: 221, 267, 442, 447, 489, 660, 680, 823, 823 DT12, 880, 880 DT12, 2442	

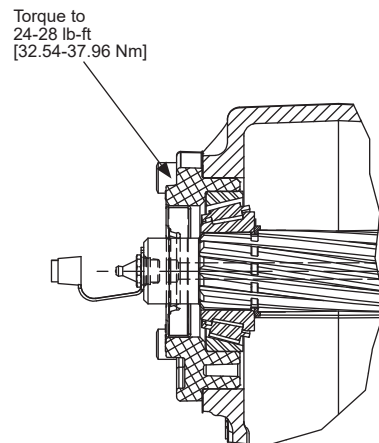

* Recommended Grease: Texaco Coupling Grease, Code 1912 or Equivalent

NOTE: PUMP INSTALLATION PRECAUTIONS

Pump support brackets may be required - see General Safety information section for pump support bracket requirements. Also remember to pack the female PTO shaft with grease before installing the pump to the PTO.

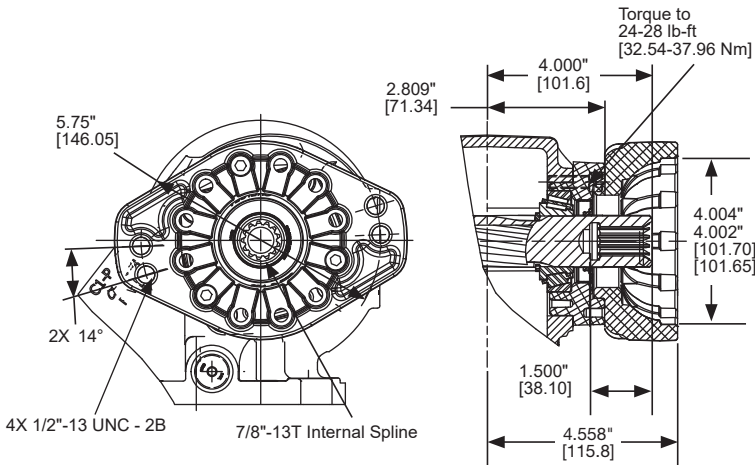

Option Code – GA	
Type	Direct Mount
Shaft	SAE B (7/8" - 13T)
Flange	Rotatable SAE B 2-Bolt
Rotates in 30° Increments (*Greaseable)	
PTO Series: 221, 267, 442, 447, 489, 660, 680, 2442	

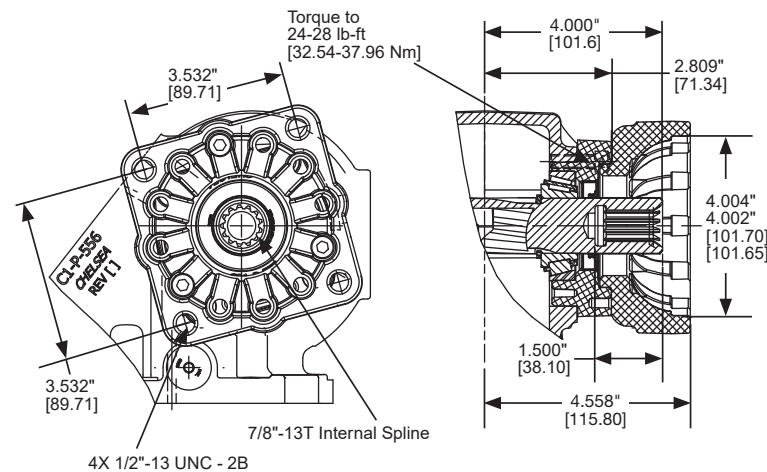

Option Code – GB	
Type	Direct Mount
Shaft	SAE B (7/8" - 13T)
Flange	Rotatable SAE B 4-Bolt
Rotates in 30° Increments (*Greaseable)	
PTO Series: 221, 267, 442, 447, 489, 660, 680, 2442	

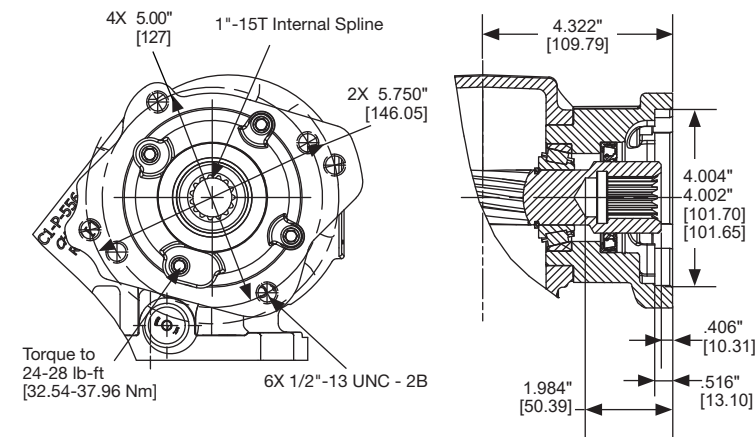

Option Code – GF	
Type	Direct Mount
Shaft	SAE BB (1" - 15T)
Flange	SAE B 2 or 4-Bolt
(*Greaseable)	
PTO Series: 221, 267, 442, 447, 489, 660, 680, 2442	

* Recommended Grease: Texaco Coupling Grease, Code 1912 or Equivalent

NOTE: PUMP INSTALLATION PRECAUTIONS

Pump support brackets may be required - see General Safety information section for pump support bracket requirements. Also remember to pack the female PTO shaft with grease before installing the pump to the PTO.

Option Code - GH	
Type	Direct Mount
Shaft	SAE BB (1" - 15T)
Flange	Rotatable SAE B 2-Bolt
Rotates in 30° Increments (*Greaseable)	
PTO Series: 660, 680	

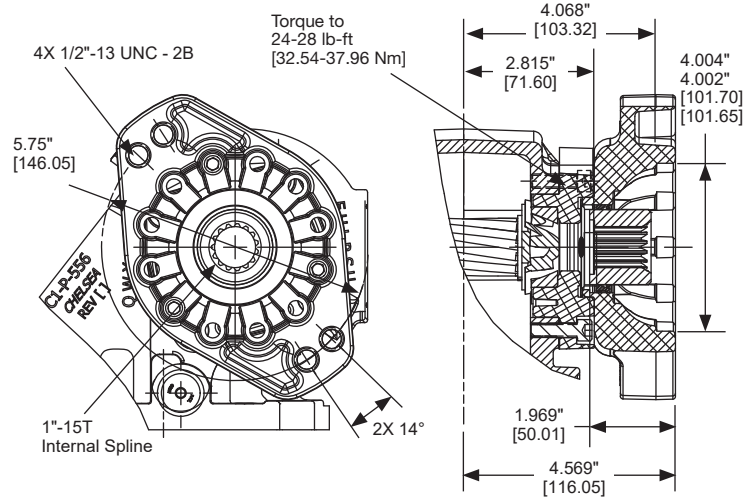

Option Code - GK	
Type	Direct Mount
Shaft	SAE B (7/8" - 13T)
Flange	SAE B 2 or 4-Bolt
(*Greaseable)	
PTO Series: 221, 267, 442, 447, 489, 660, 680, 2442	

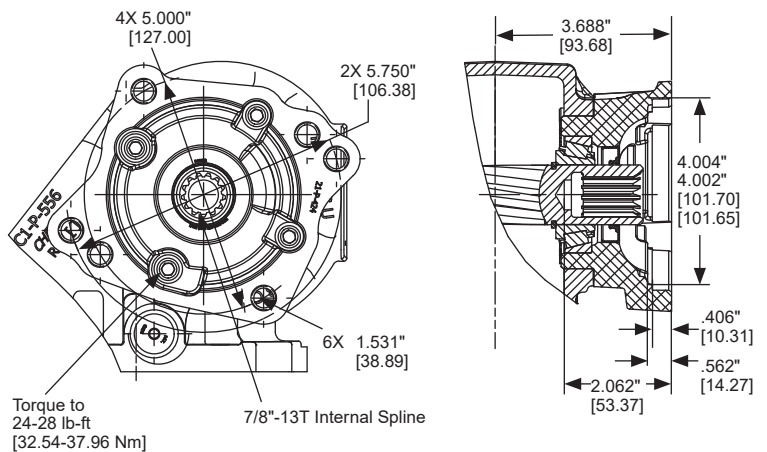

Option Code - GQ	
Type	Direct Mount
Shaft	SAE B (7/8" - 13T)
Flange	SAE B 2 or 4-Bolt
(*Greaseable)	
PTO Series: 221, 267, 442, 447, 489, 660, 680, 2442	

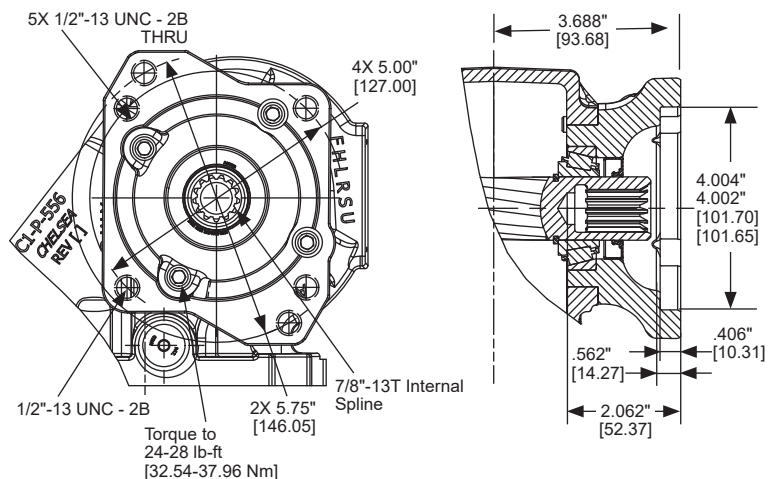

* Recommended Grease: Texaco Coupling Grease, Code 1912 or Equivalent

NOTE: PUMP INSTALLATION PRECAUTIONS

Pump support brackets may be required - see General Safety information section for pump support bracket requirements. Also remember to pack the female PTO shaft with grease before installing the pump to the PTO.

Flanges

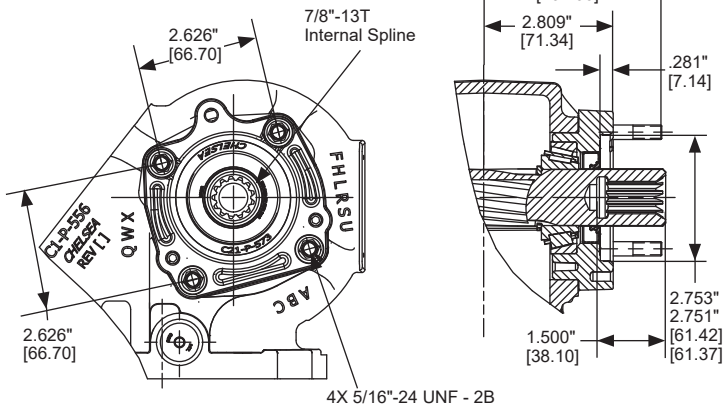

Option Code – GR	
Type	Direct Mount
Shaft	SAE B (7/8" - 13T)
Flange	Chelsea Special (Cloverleaf)
(*Greaseable)	
PTO Series: 221, 267, 442, 447, 489, 660, 680, 2442	

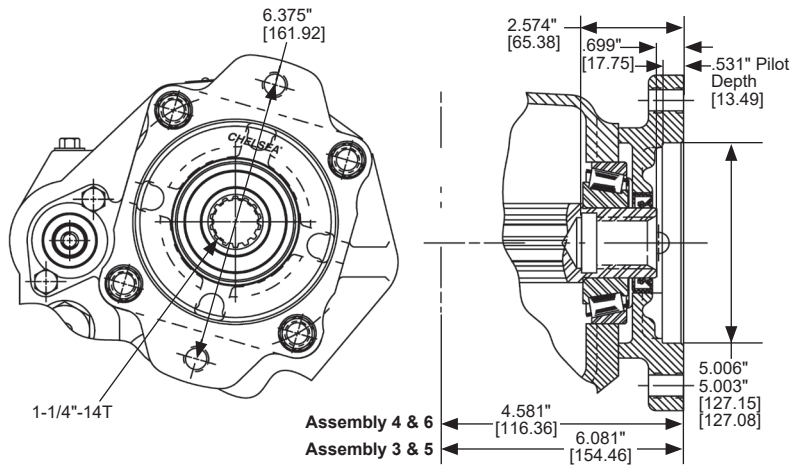

Option Code – GS	
Type	Direct Mount
Shaft	SAE C (1-1/4" - 14T)
Flange	SAE C 2 or 4-Bolt
(*Greaseable)	
PTO Series: 823, 823 DT12	

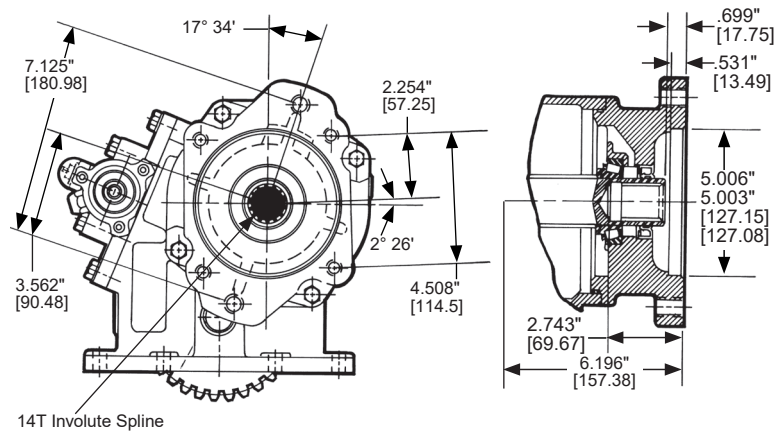

Option Code – GS	
Type	Direct Mount
Shaft	SAE C (1-1/4" - 14T)
Flange	SAE C 2 or 4-Bolt
(*Greaseable)	
PTO Series: 880, 880 DT12	

* Recommended Grease: Texaco Coupling Grease, Code 1912 or Equivalent

NOTE: PUMP INSTALLATION PRECAUTIONS

Pump support brackets may be required - see General Safety information section for pump support bracket requirements. Also remember to pack the female PTO shaft with grease before installing the pump to the PTO.

Option Code – GU	
Type	Direct Mount
Shaft	SAE C (1-1/4" - 14T)
Flange	SAE C 2-Bolt
(*Greaseable)	
PTO Series: 823, 823 DT12	

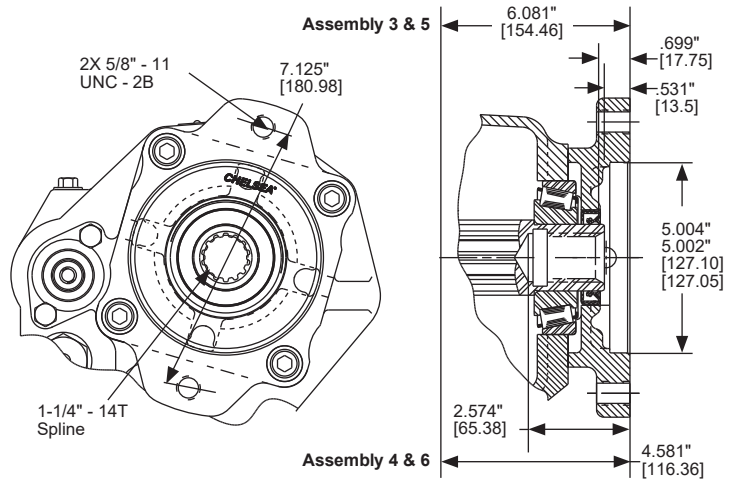

Option Code – GY	
Type	Direct Mount
Shaft	DIN 5462 (B8x32x36-8T)
Flange	ISO 7653 Pump Mounting
(*Greaseable)	
PTO Series: 660, 680	

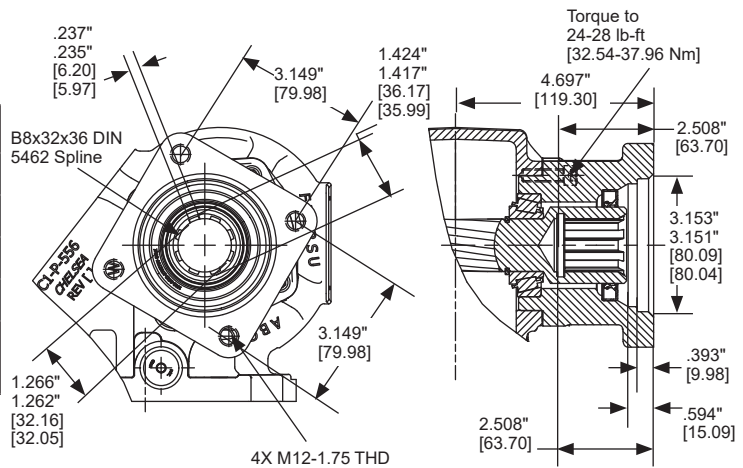

Option Code – GZ	
Type	Direct Mount
Shaft	SAE C (1-1/4" - 14T)
Flange	SAE B 2 or 4-Bolt
(*Greaseable)	
PTO Series: 660, 680	

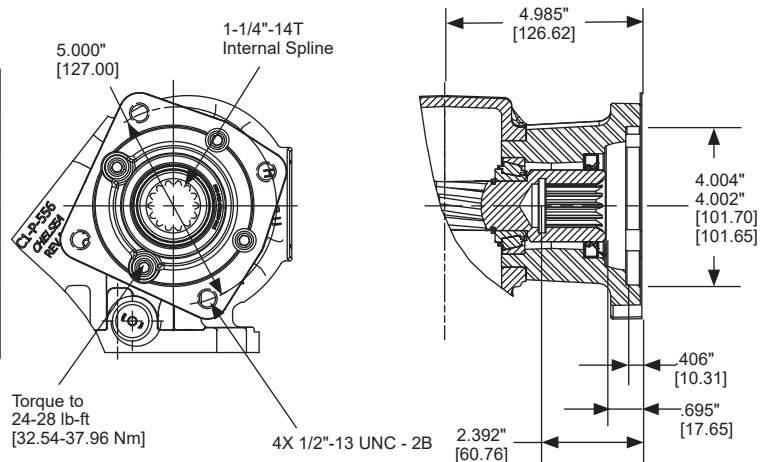

* Recommended Grease: Texaco Coupling Grease, Code 1912 or Equivalent

NOTE: PUMP INSTALLATION PRECAUTIONS

Pump support brackets may be required - see General Safety information section for pump support bracket requirements. Also remember to pack the female PTO shaft with grease before installing the pump to the PTO.

Flanges

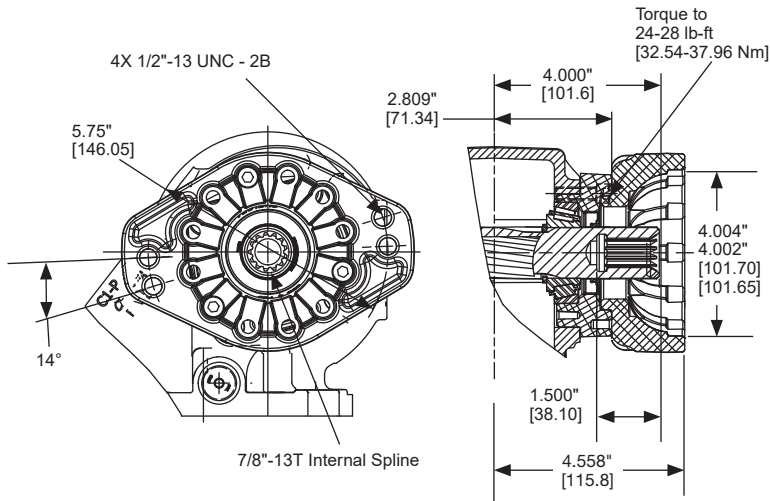

Option Code – RA	
Type	Direct Mount
Shaft	SAE B (7/8" - 13T)
Flange	Rotatable SAE B 2-Bolt
Rotates in 30° Increments	
PTO Series: 221, 267, 442, 447, 489, 660, 680, 2442	

Flanges

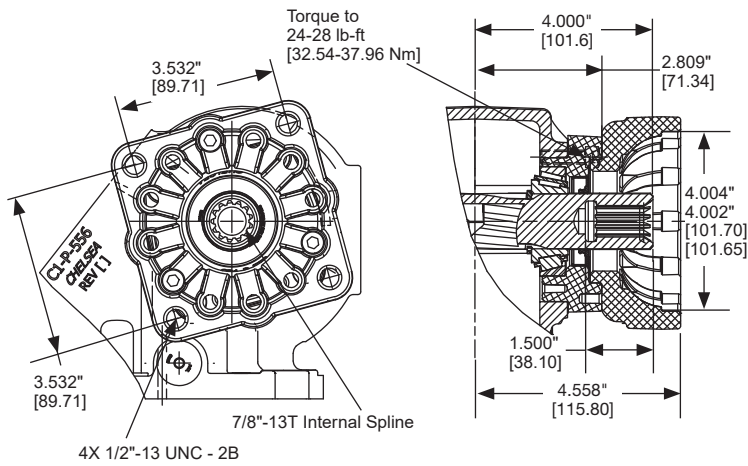

Option Code – RB	
Type	Direct Mount
Shaft	SAE B (7/8" - 13T)
Flange	Rotatable SAE B 4-Bolt
Rotates in 30° Increments	
PTO Series: 221, 267, 442, 447, 489, 660, 680, 2442	

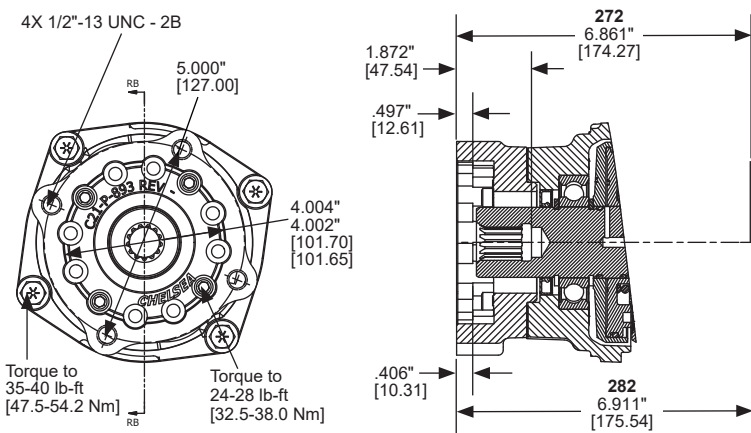

Option Code – RB	
Type	Direct Mount
Shaft	SAE B (7/8" - 13T)
Flange	Rotatable SAE B 4-Bolt
Rotates in 30° Increments	
PTO Series: 272, 272-FORD, 272U, 282	

NOTE: PUMP INSTALLATION PRECAUTIONS

Pump support brackets may be required - see General Safety information section for pump support bracket requirements. Also remember to pack the female PTO shaft with grease before installing the pump to the PTO.

Option Code – RB	
Type	Direct Mount
Shaft	SAE B (7/8" - 13T)
Flange	Rotatable SAE B 4-Bolt
Rotates in 30° Increments	
PTO Series: 280, 287	

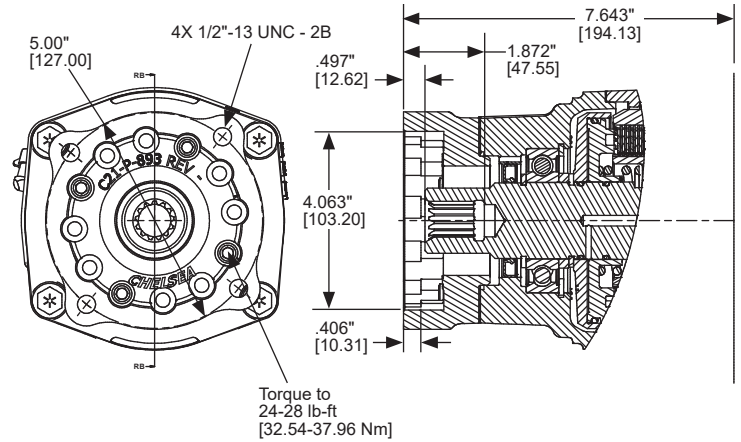

Option Code – RC	
Type	Direct Mount
Shaft	SAE A (5/8" - 9T)
Flange	Rotatable SAE A 2-Bolt
Rotates in 30° Increments	
PTO Series: 221, 267, 442, 447, 489, 660, 680, 2442	

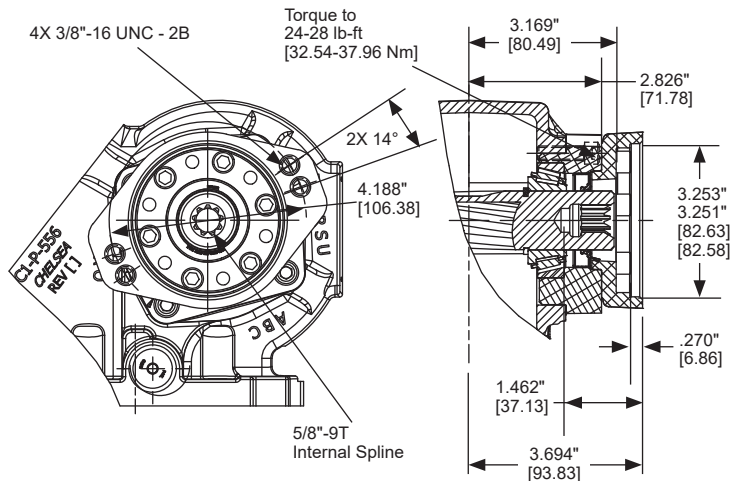

Option Code – RD	
Type	Direct Mount
Shaft	SAE B (7/8" - 13T)
Flange	Rotatable SAE A 2-Bolt
Rotates in 30° Increments	
PTO Series: 221, 267, 442, 447, 489, 660, 680, 2442	

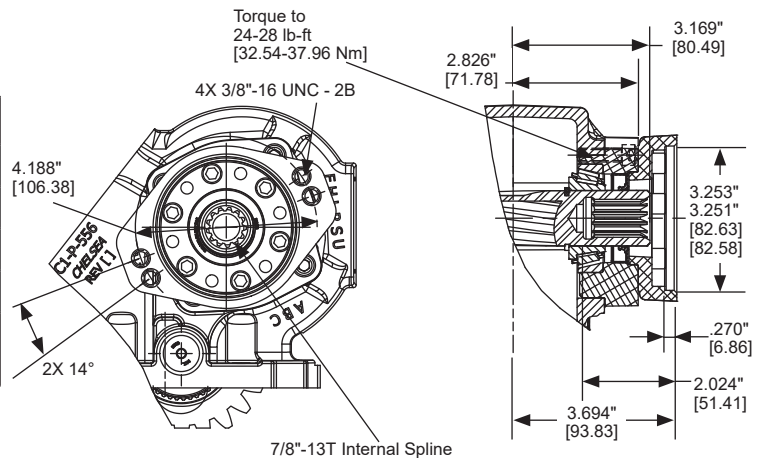

Flanges

NOTE: PUMP INSTALLATION PRECAUTIONS

Pump support brackets may be required - see General Safety information section for pump support bracket requirements. Also remember to pack the female PTO shaft with grease before installing the pump to the PTO.

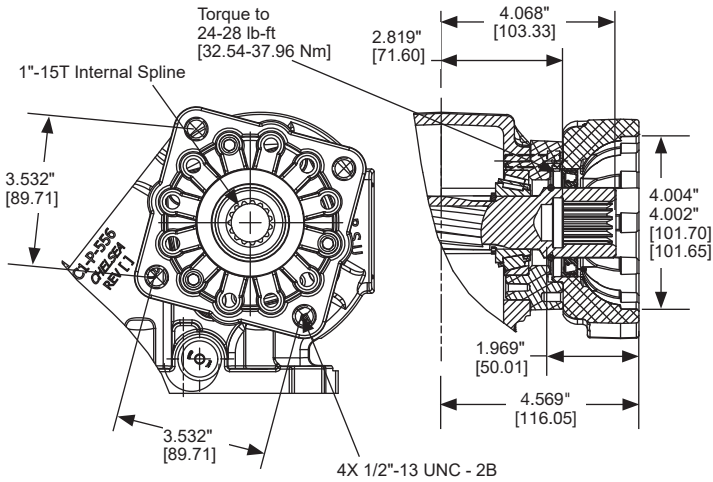

Option Code – RE	
Type	Direct Mount
Shaft	SAE BB (1" - 15T)
Flange	Rotatable SAE B 4-Bolt
Rotates in 30° Increments	
PTO Series: 221, 267, 442, 447, 489, 660, 680, 2442	

Flanges

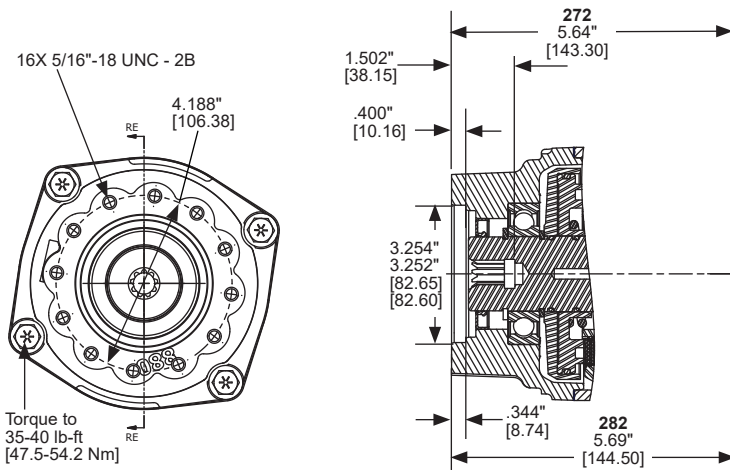

Option Code – RE	
Type	Direct Mount
Shaft	SAE A (5/8" - 9T)
Flange	Rotatable SAE A 2-Bolt
Pump Rotates in 30° Increments	
PTO Series: 272, 272-FORD, 282	

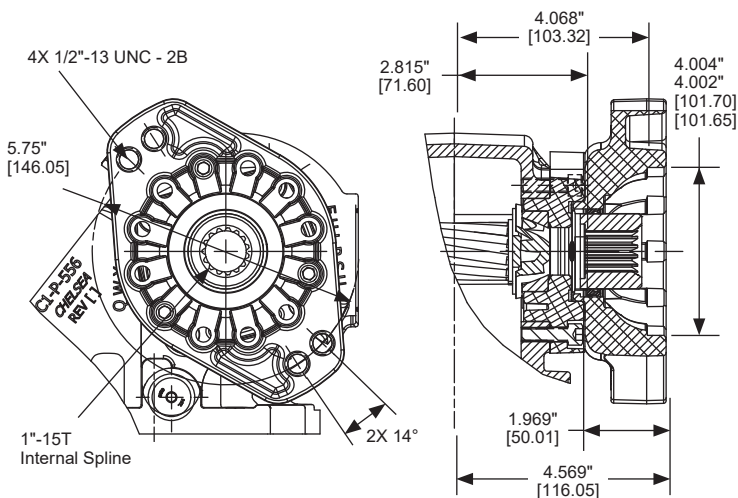

Option Code – RF	
Type	Direct Mount
Shaft	SAE BB (1" - 15T)
Flange	Rotatable SAE B 2-Bolt
Rotates in 30° Increments	
PTO Series: 221, 267, 442, 447, 489, 660, 680, 2442	

NOTE: PUMP INSTALLATION PRECAUTIONS

Pump support brackets may be required - see General Safety information section for pump support bracket requirements. Also remember to pack the female PTO shaft with grease before installing the pump to the PTO.

Option Code – RF	
Type	Direct Mount
Shaft	SAE BB Shaft (1" - 15T)
Flange	Rotatable SAE B 2 or 4-Bolt
Rotates in 30° Increments	
PTO Series: 272, 272-FORD, 272U, 282	

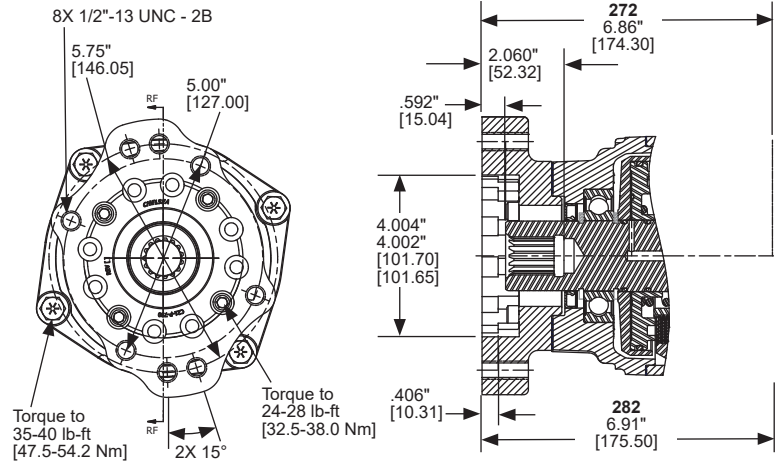

Option Code – RF	
Type	Direct Mount
Shaft	SAE BB (1" - 15T)
Flange	Rotatable SAE B 2 or 4-Bolt
Rotates in 30° Increments	
PTO Series: 280, 287	

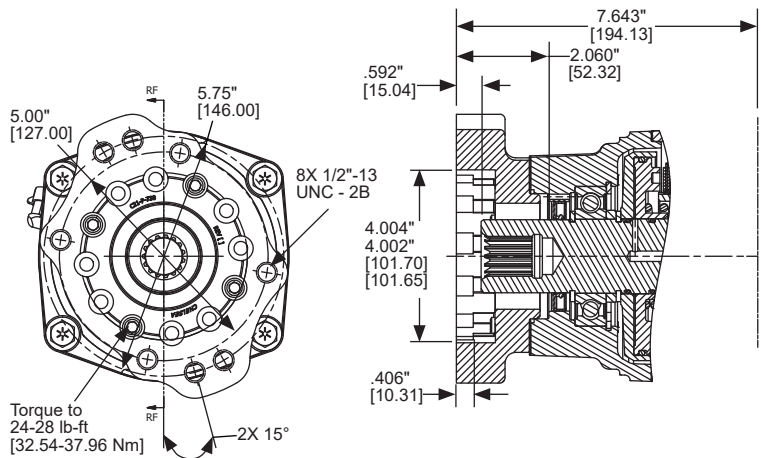

Option Code – RF	
Type	Direct Mount
Shaft	SAE BB (1" - 15T)
Flange	Rotatable SAE B 2 or 4-Bolt
Rotates in 30° Increments	
PTO Series: 870, 877	

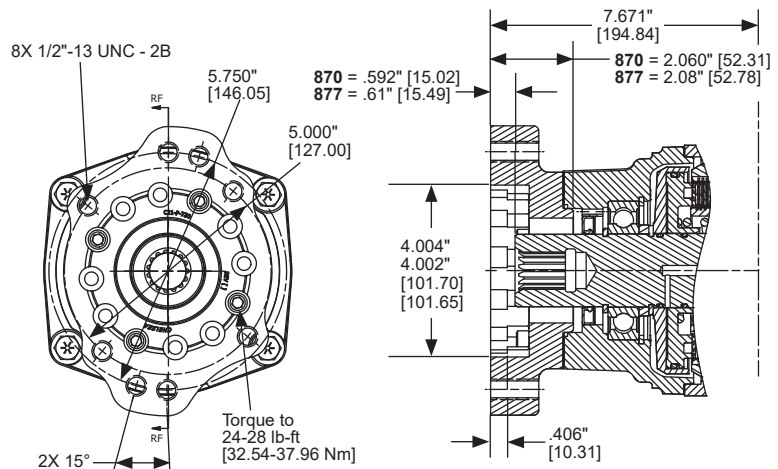

NOTE: PUMP INSTALLATION PRECAUTIONS

Pump support brackets may be required - see General Safety information section for pump support bracket requirements. Also remember to pack the female PTO shaft with grease before installing the pump to the PTO.

Flanges

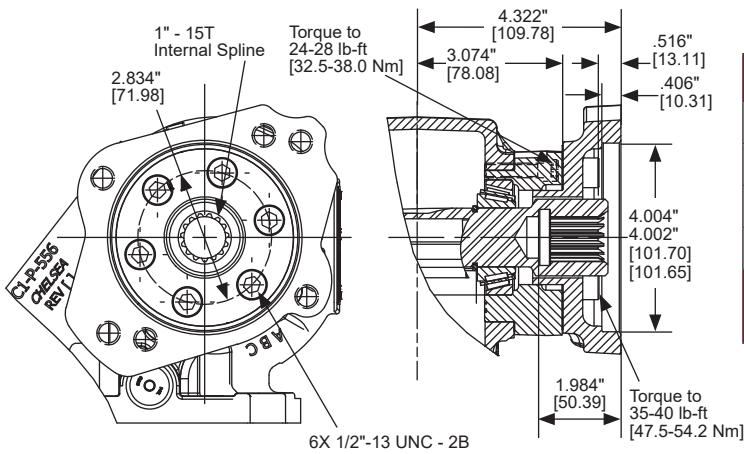

Option Code – RJ	
Type	Direct Mount
Shaft	SAE BB Shaft (1" - 15T)
Flange	Rotatable SAE B 2 or 4-Bolt
Rotates in 30° Increments	
PTO Series: 267, 489, 660	

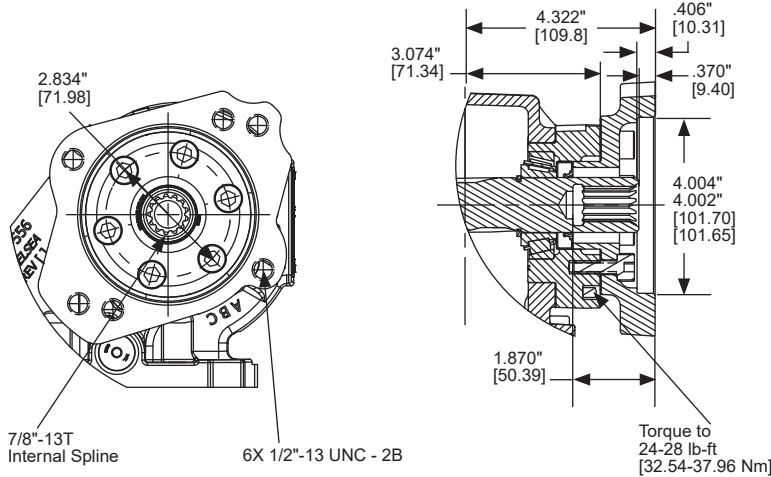

Option Code – RK	
Type	Direct Mount
Shaft	SAE B (7/8" - 13T)
Flange	Rotatable SAE B 2 or 4-Bolt
Rotates in 60° Increments	
PTO Series: 221, 267, 442, 447, 489, 489 DT12, 660, 680, 680 DT12, 2442	

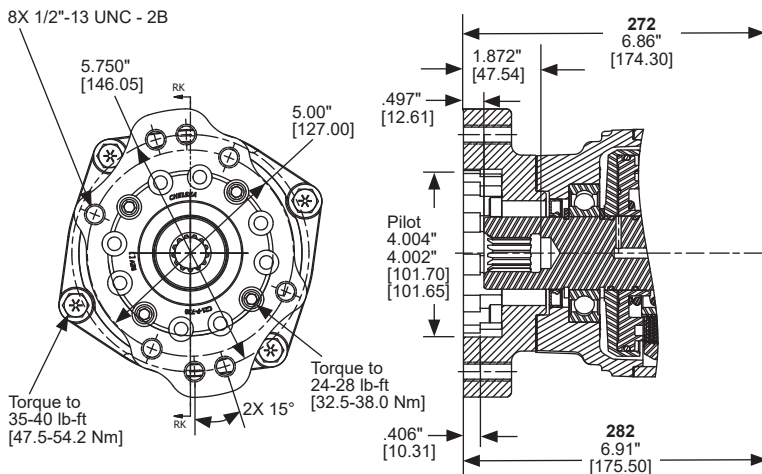

Option Code – RK	
Type	Direct Mount
Shaft	SAE B Shaft (7/8" - 13T)
Flange	Rotatable SAE B 2 or 4-Bolt
Rotates in 30° Increments	
PTO Series: 272, 272-FORD, 272U, 282	

NOTE: PUMP INSTALLATION PRECAUTIONS

Pump support brackets may be required - see General Safety information section for pump support bracket requirements. Also remember to pack the female PTO shaft with grease before installing the pump to the PTO.

Option Code – RK	
Type	Direct Mount
Shaft	SAE B (7/8" - 13T)
Flange	Rotatable SAE B 2 or 4-Bolt
Rotates in 30° Increments	
PTO Series: 280, 287	

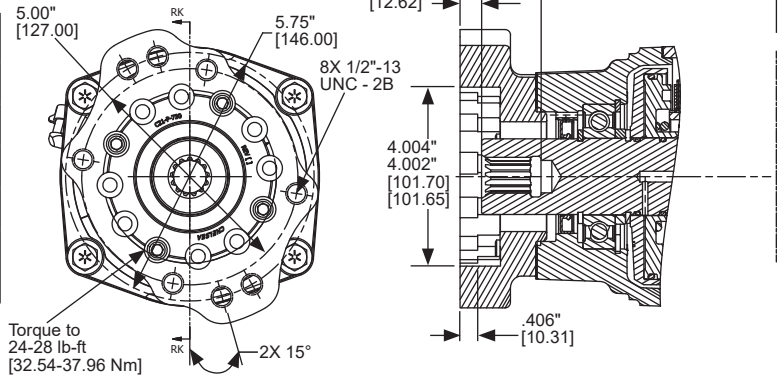

Option Code – RK	
Type	Direct Mount
Shaft	SAE B (7/8" - 13T)
Flange	Rotatable SAE B 2 or 4-Bolt
Rotates in 30° Increments	
PTO Series: 870, 877	

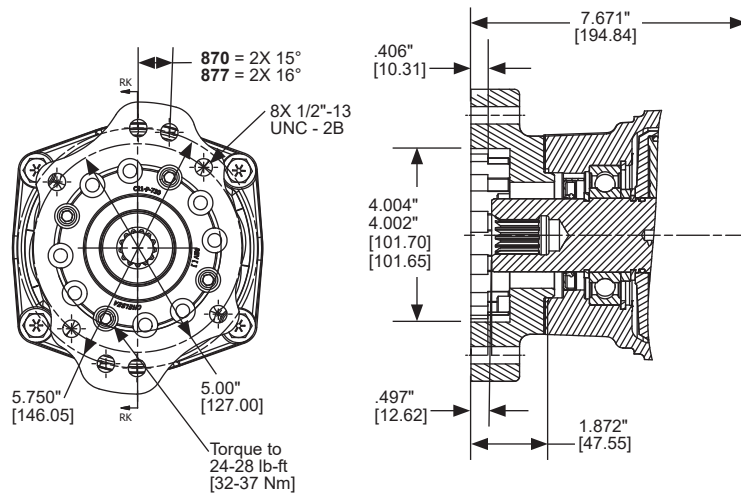

Option Code – RS	
Type	Direct Mount
Shaft	Rotatable SAE C Shaft (1-1/4" - 14T)
Flange	SAE C 2 or 4-Bolt
Rotates in 30° Increments	
PTO Series: 272, 272-FORD, 272U, 282	

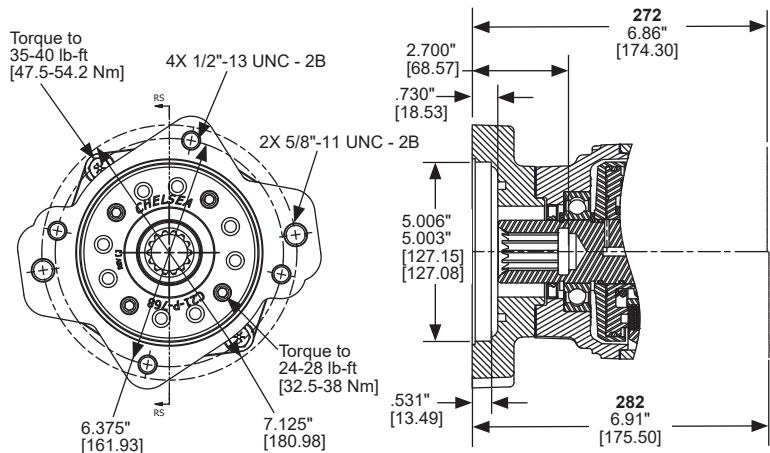

Flanges

* Recommended Grease: Texaco Coupling Grease, Code 1912 or Equivalent

NOTE: PUMP INSTALLATION PRECAUTIONS

Pump support brackets may be required - see General Safety information section for pump support bracket requirements. Also remember to pack the female PTO shaft with grease before installing the pump to the PTO.

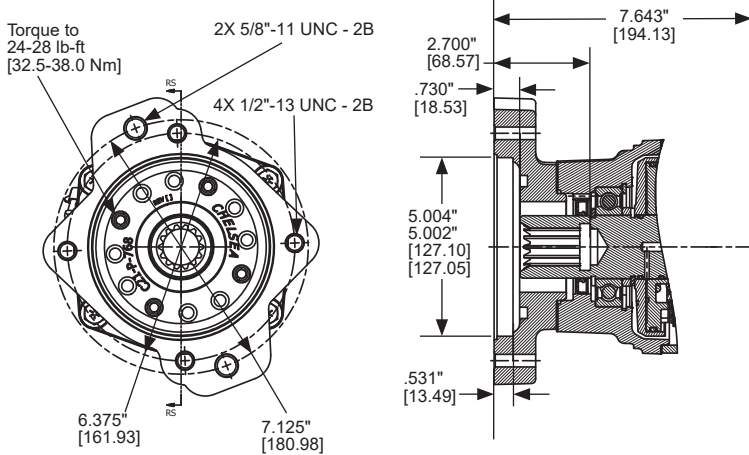

Option Code – RS	
Type	Direct Mount
Shaft	SAE C (1-1/4" - 14T)
Flange	Rotatable SAE C 2 or 4-Bolt
Rotates in 30° Increments	
PTO Series: 280, 287	

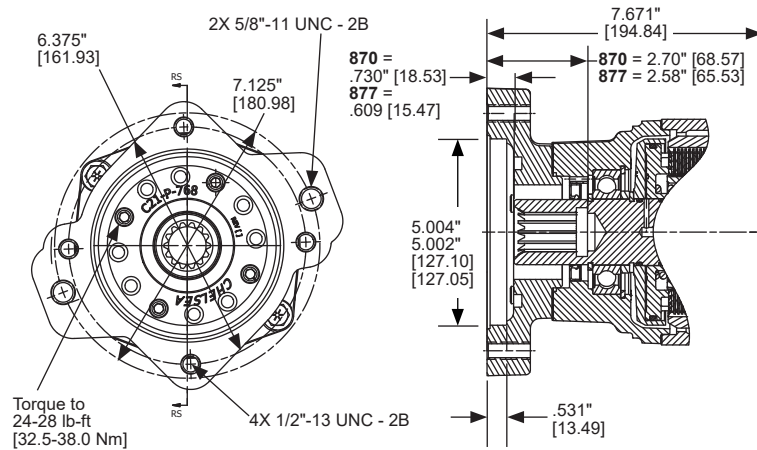

Option Code – RS	
Type	Direct Mount
Shaft	SAE C (1-1/4" - 14T)
Flange	Rotatable SAE C 2 or 4-Bolt
Rotates in 30° Increments	
PTO Series: 870, 877	

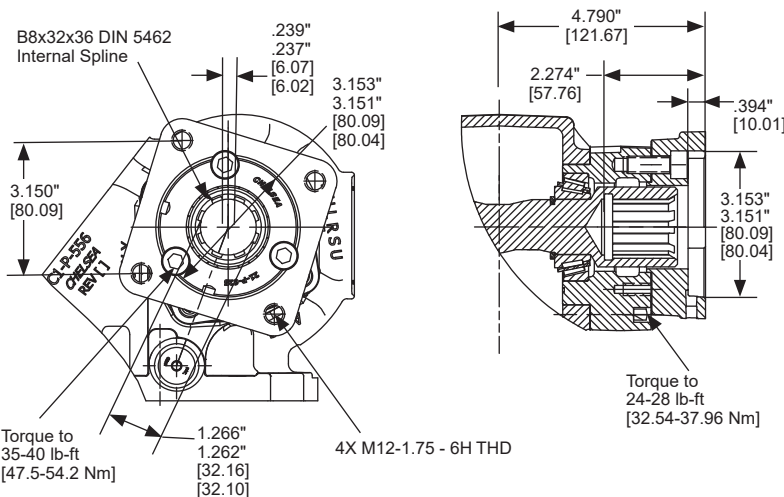

Option Code – RY	
Type	Direct Mount
Shaft	DIN 5462 (B8x32x36-8T)
Flange	Rotatable ISO 7653 Pump Mount
Rotates in 120° Increments	
PTO Series: 221, 267, 442, 447, 489, 660, 680, 2442	

* Recommended Grease: Texaco Coupling Grease, Code 1912 or Equivalent

NOTE: PUMP INSTALLATION PRECAUTIONS

Pump support brackets may be required - see General Safety information section for pump support bracket requirements. Also remember to pack the female PTO shaft with grease before installing the pump to the PTO.

Flanges

Option Code – RY	
Type	Direct Mount
Shaft	DIN 5462 (B8x32x36-8T)
Flange	Rotatable ISO 7653 Pump Mount
Rotates in 30° Increments	
PTO Series: 272, 272-FORD, 272U, 282	

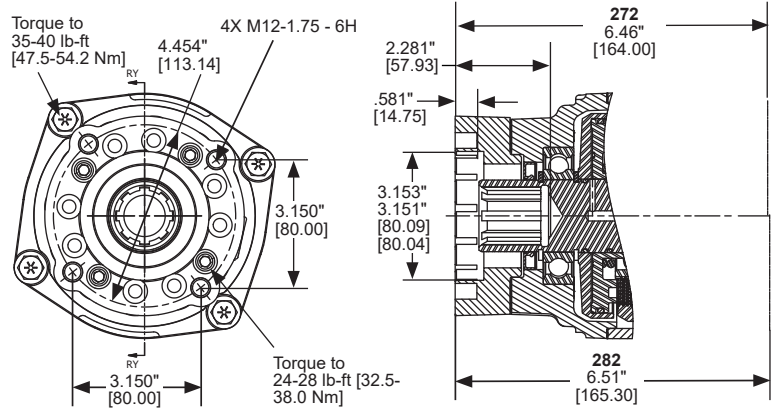

Option Code – RY	
Type	Direct Mount
Shaft	DIN 5462 (B8x32x36-8T)
Flange	Rotatable ISO 7653 Pump Mount
Rotates in 30° Increments	
PTO Series: 280, 287	

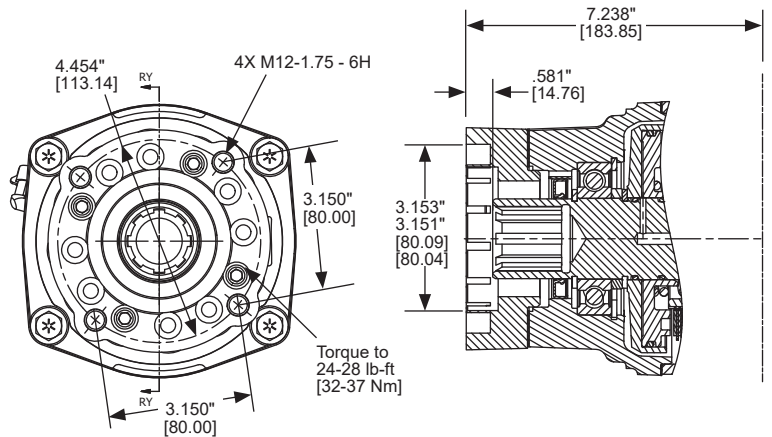

Option Code – RY	
Type	Direct Mount
Shaft	DIN 5462 (B8x32x36-8T)
Flange	Rotatable ISO 7653 Pump Mount
Rotates in 30° Increments	
PTO Series: 870, 877	

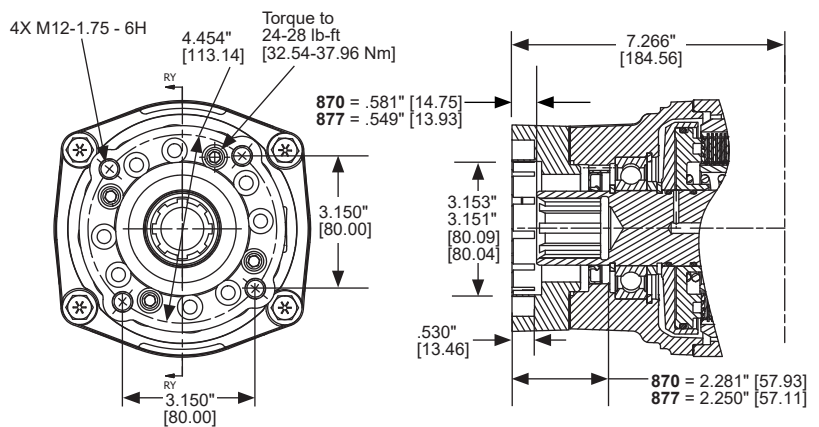

Flanges

* Recommended Grease: Texaco Coupling Grease, Code 1912 or Equivalent

NOTE: PUMP INSTALLATION PRECAUTIONS

Pump support brackets may be required - see General Safety information section for pump support bracket requirements. Also remember to pack the female PTO shaft with grease before installing the pump to the PTO.

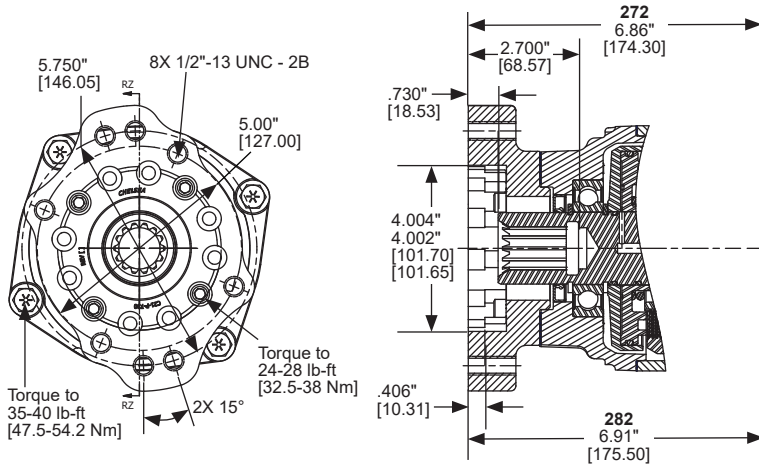

Option Code – RZ	
Type	Direct Mount
Shaft	SAE C Shaft (1-1/4" 14T)
Flange	Rotatable SAE B 2 or 4-Bolt
Rotates in 30° Increments	
PTO Series: 272, 272-FORD, 272U, 282	

Flanges

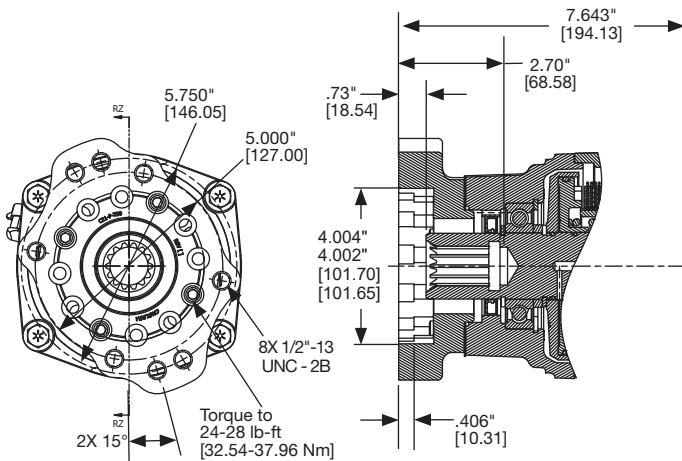

Option Code – RZ	
Type	Direct Mount
Shaft	SAE C (1-1/4" - 14T)
Flange	Rotatable SAE B 2 or 4-Bolt
Rotates in 30° Increments	
PTO Series: 280, 287	

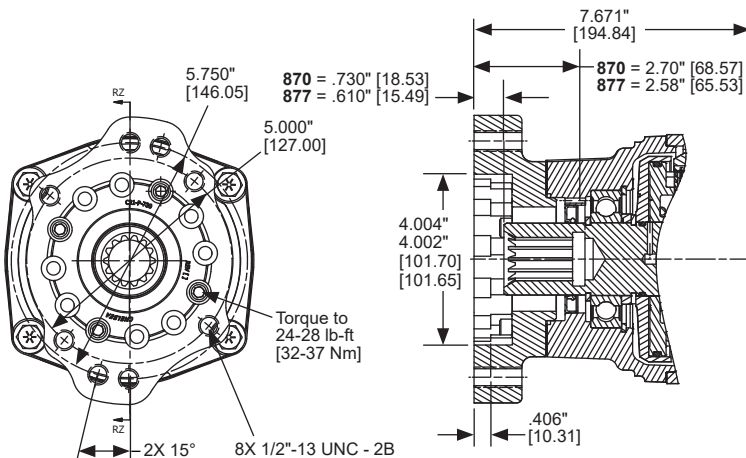

Option Code – RZ	
Type	Direct Mount
Shaft	SAE C (1-1/4" - 14T)
Flange	Rotatable SAE B 2 or 4-Bolt
Rotates in 30° Increments	
PTO Series: 870, 877	

* Recommended Grease: Texaco Coupling Grease, Code 1912 or Equivalent

NOTE: PUMP INSTALLATION PRECAUTIONS

Pump support brackets may be required - see General Safety information section for pump support bracket requirements. Also remember to pack the female PTO shaft with grease before installing the pump to the PTO.

Option Code – SB	
Type	Remote Mount
Shaft	Smart Start DIN 120 Flange
PTO Series: 280	

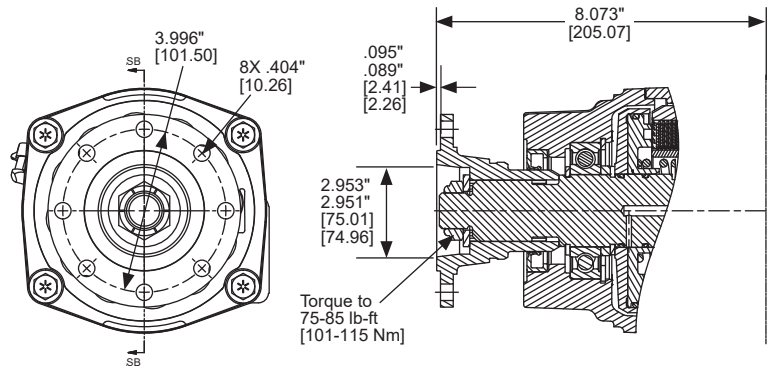

Option Code – SB	
Type	Remote Mount
Shaft	Smart Start DIN 120 Flange
PTO Series: 870	

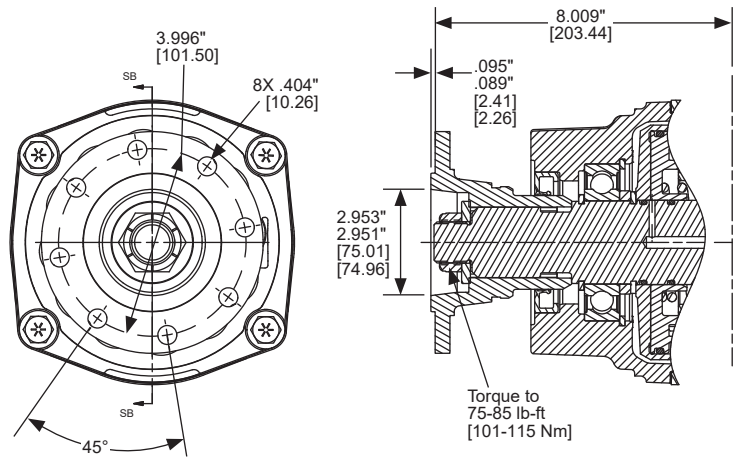

Option Code – SC	
Type	Remote Mount
Shaft	Smart Start DIN 100 Flange
PTO Series: 280	

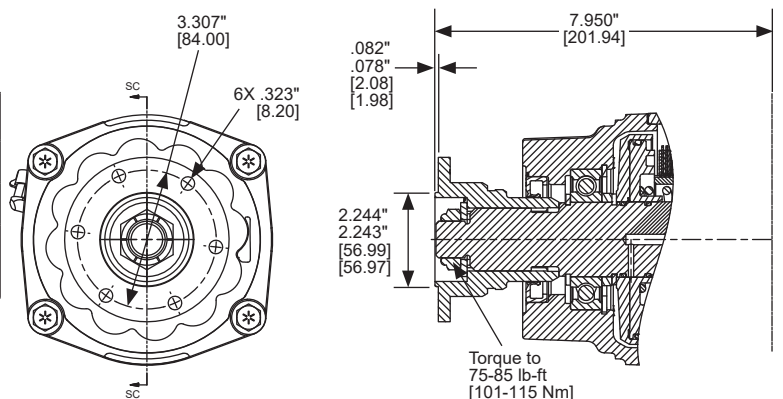

Flanges

* Recommended Grease: Texaco Coupling Grease, Code 1912 or Equivalent

NOTE: PUMP INSTALLATION PRECAUTIONS

Pump support brackets may be required - see General Safety information section for pump support bracket requirements. Also remember to pack the female PTO shaft with grease before installing the pump to the PTO.

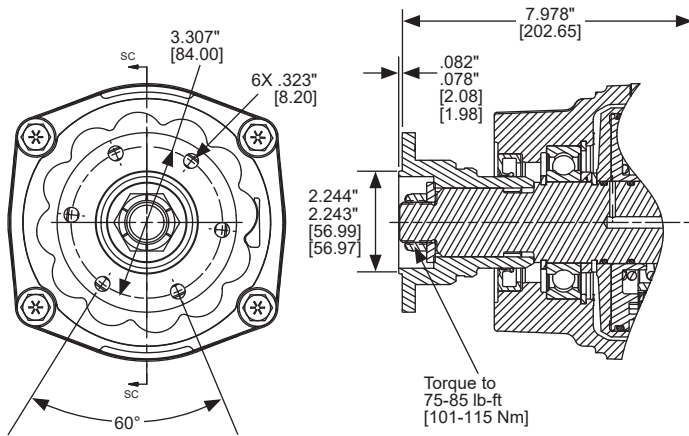

Option Code – SC	
Type	Remote Mount
Shaft	Smart Start DIN 100 Flange
PTO Series: 870	

Flanges

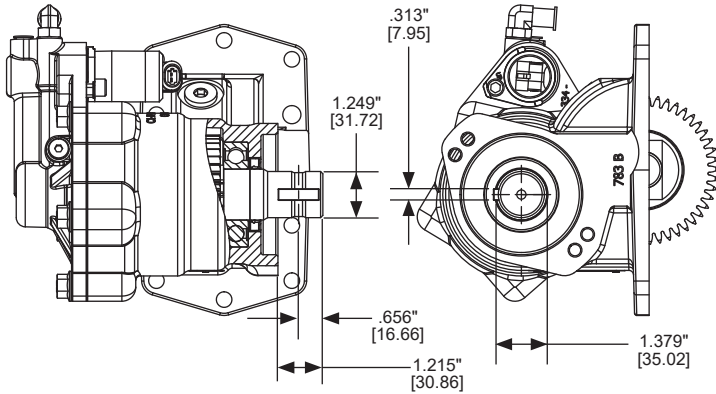

Option Code – SD	
Type	Remote Mount
Shaft	Smart Start (1-1/4" Rd. - 5/16" Key)
PTO Series: 210	

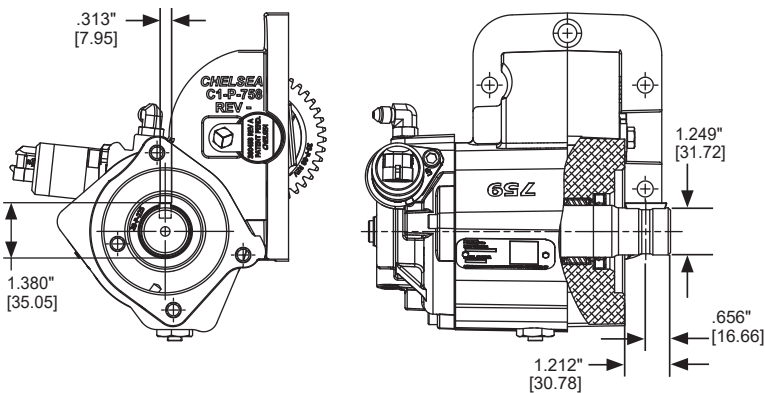

Option Code – SD	
Type	Remote Mount
Shaft	Smart Start (1-1/4" Rd. - 5/16" Key)
PTO Series: 249	

* Recommended Grease: Texaco Coupling Grease, Code 1912 or Equivalent

NOTE: PUMP INSTALLATION PRECAUTIONS

Pump support brackets may be required - see General Safety information section for pump support bracket requirements. Also remember to pack the female PTO shaft with grease before installing the pump to the PTO.

Option Code – SD	
Type	Remote Mount
Shaft	Smart Start (1-1/4" Rd. - 5/16" Key)
PTO Series: 272, 272-FORD, †272U, 282	

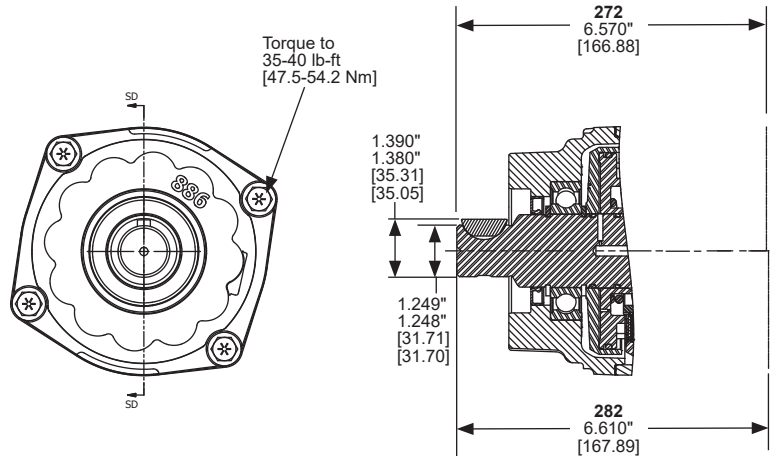

† Coming Soon

Option Code – SD	
Type	Remote Mount
Shaft	Smart Start (1-1/4" Rd. - 5/16" Key)
PTO Series: 280	

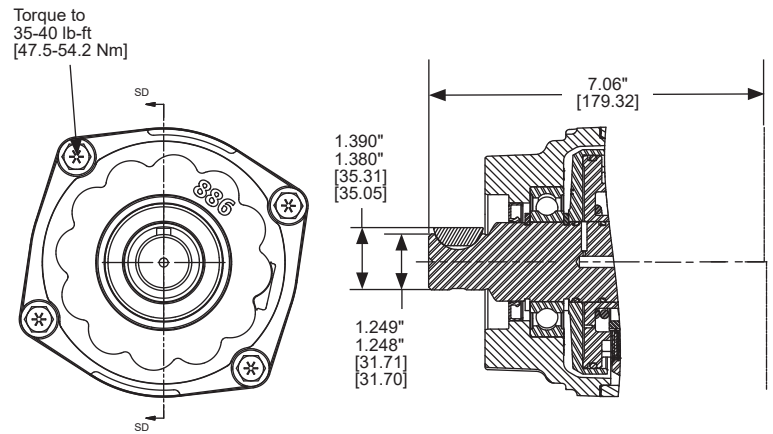

Flanges

Option Code – SQ	
Type	Direct Mount
Shaft	SAE B (7/8" - 13T)
Flange	SAE B 4-Bolt
PTO Series: 442, 489, 2442	

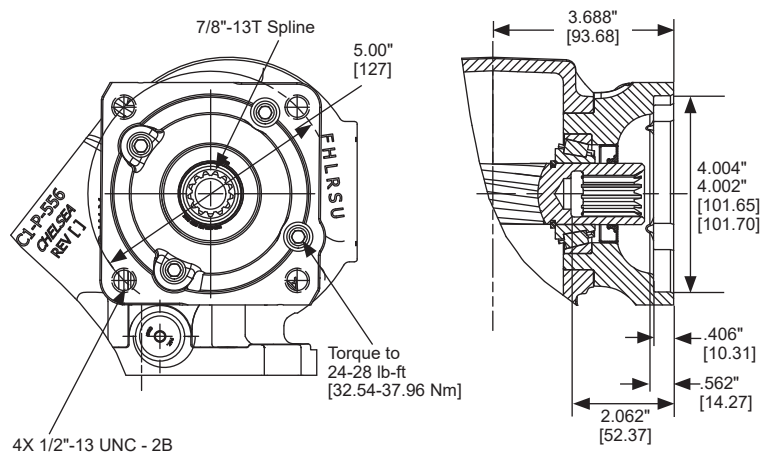

* Recommended Grease: Texaco Coupling Grease, Code 1912 or Equivalent

NOTE: PUMP INSTALLATION PRECAUTIONS

Pump support brackets may be required - see General Safety information section for pump support bracket requirements. Also remember to pack the female PTO shaft with grease before installing the pump to the PTO.

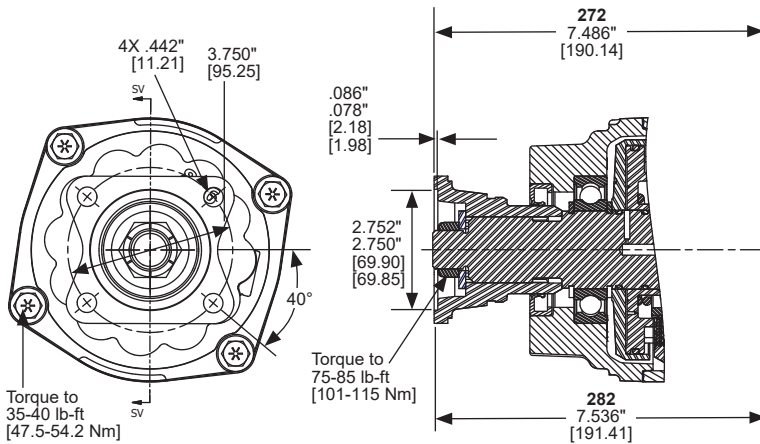

Option Code – SV	
Type	Remote Mount
Shaft	Smart Start 1410 Companion Flange
PTO Series: 272, 272-FORD, †272U, 282	

† Coming Soon

Flanges

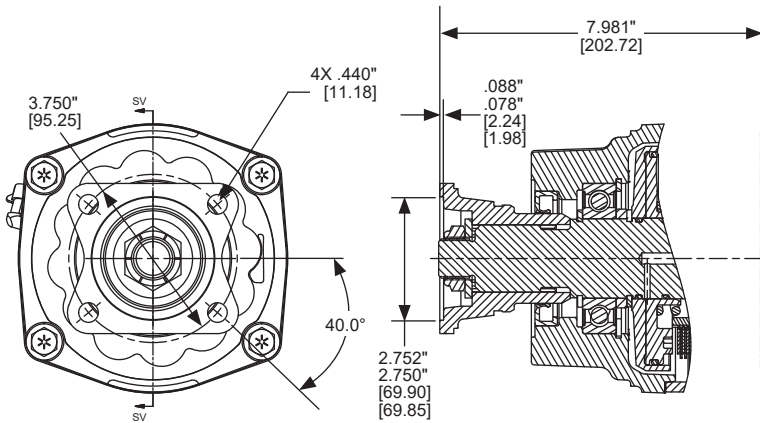

Option Code – SV	
Type	Remote Mount
Shaft	Smart Start 1410 Companion Flange
PTO Series: 280, 870	

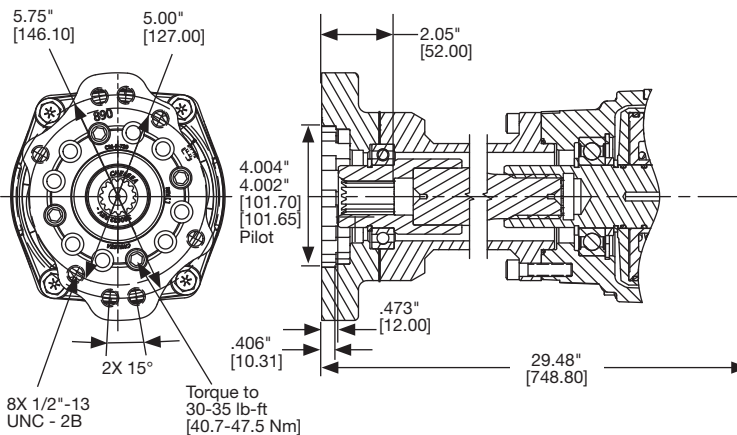

Option Code – TF	
Type	Direct Mount
Shaft	SAE BB (1" - 15T 16/32 DP)
Flange	SAE B Pilot 2 or 4-Bolt
Rotates in 15° Increments	
PTO Series: 870-XL, 877-XL	

* Recommended Grease: Texaco Coupling Grease, Code 1912 or Equivalent

NOTE: PUMP INSTALLATION PRECAUTIONS

Pump support brackets may be required - see General Safety information section for pump support bracket requirements. Also remember to pack the female PTO shaft with grease before installing the pump to the PTO.

Option Code – TK	
Type	Direct Mount
Shaft	SAE B (7/8" - 13T 16/32 DP)
Flange	SAE B Pilot 2 or 4-Bolt
Rotates in 15° Increments	
PTO Series: 870-XL, 877-XL	

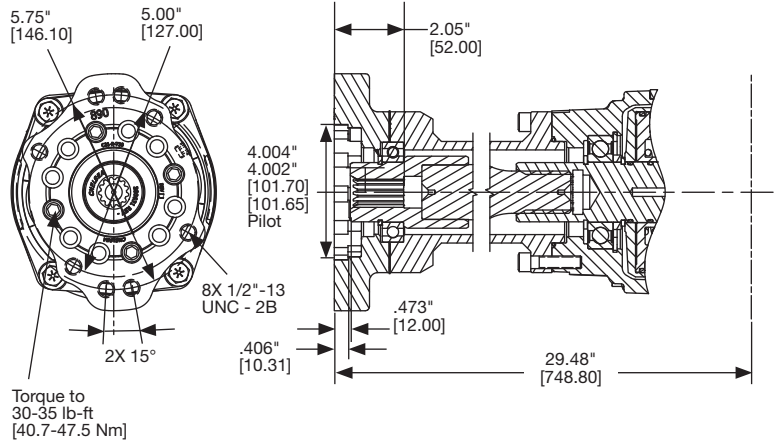

Option Code – TS	
Type	Direct Mount
Shaft	SAE C (1-1/4" - 14T 12/24 DP)
Flange	SAE C Pilot 2 or 4-Bolt
Rotates in 15° Increments	
PTO Series: 870-XL, 877-XL	

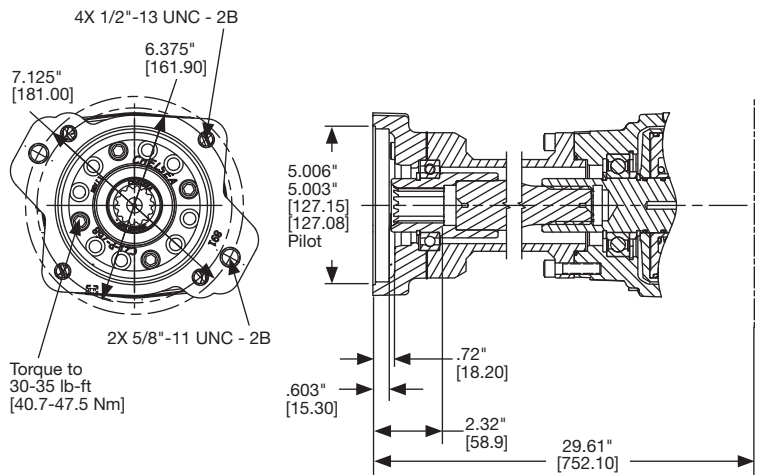

Option Code – TV	
Type	Remote Mount
Shaft	Tapered 1410 Companion Flange
Flange	N/A
PTO Series: 267	

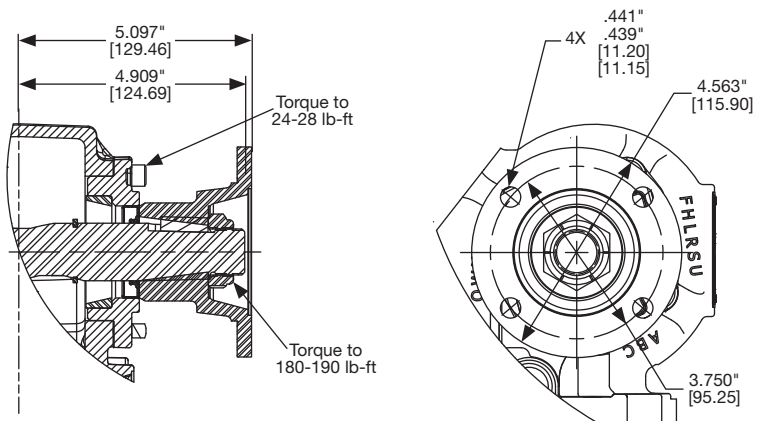

Flanges

NOTE: PUMP INSTALLATION PRECAUTIONS

Pump support brackets may be required - see General Safety information section for pump support bracket requirements. Also remember to pack the female PTO shaft with grease before installing the pump to the PTO.

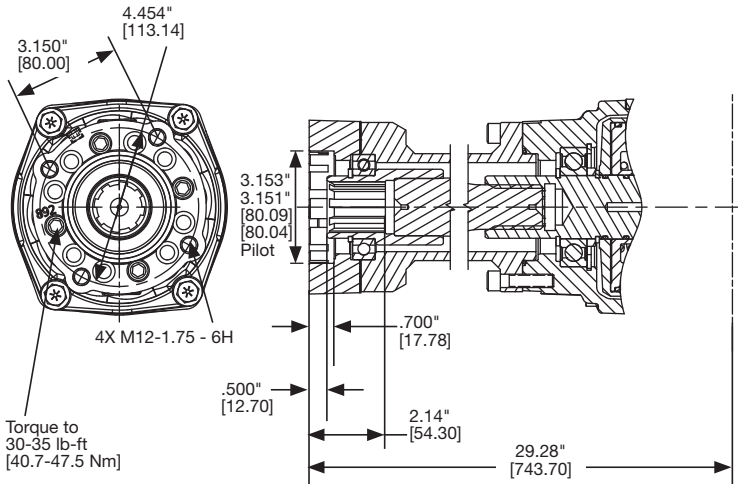

Option Code – TY	
Type	Direct Mount
Shaft	DIN 5462
Flange	ISO 7653 Pilot 4-Bolt
Rotates in 15° Increments	
PTO Series: 870-XL, 877-XL	

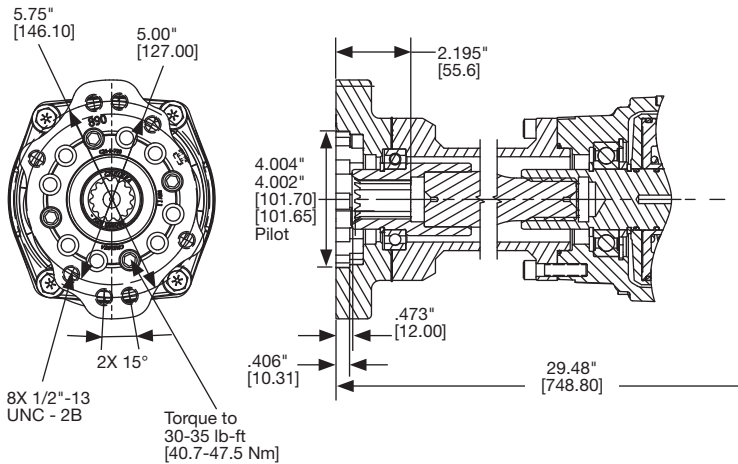

Option Code – TZ	
Type	Direct Mount
Shaft	SAE C (1-1/4" - 14T 12/24 DP)
Flange	SAE B Pilot 2 or 4-Bolt
Rotates in 15° Increments	
PTO Series: 870-XL, 877-XL	

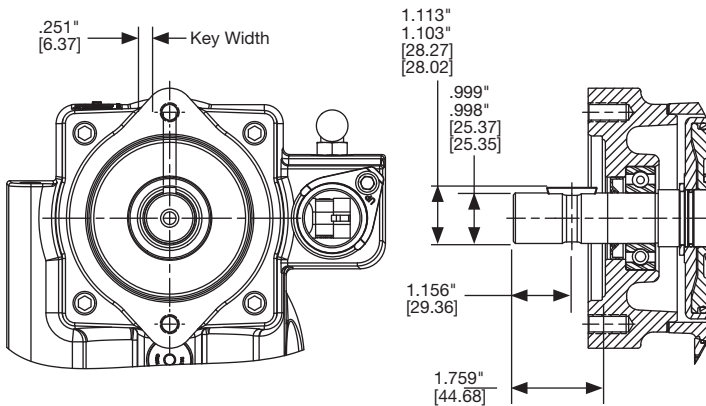

Option Code – XB	
Type	Direct Mount
Shaft	1" Rd. w/ 1/4" Key
PTO Series: 252	

NOTE: PUMP INSTALLATION PRECAUTIONS

Pump support brackets may be required - see General Safety information section for pump support bracket requirements. Also remember to pack the female PTO shaft with grease before installing the pump to the PTO.

Flanges

Option Code – XD	
Type	Remote Mount
Shaft	1-1/4" Rd. w/ 5/16" Key
PTO Series: 221, 267, 442, 447, 489, 489 DT12, 660, 680, 680 DT12, 2442	

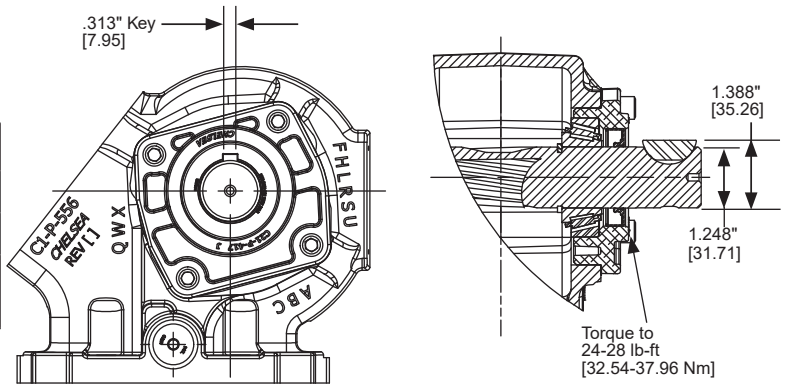

Option Code – XD	
Type	Remote Mount
Shaft	1-1/4" Rd. w/ 5/16" Key
PTO Series: 249	

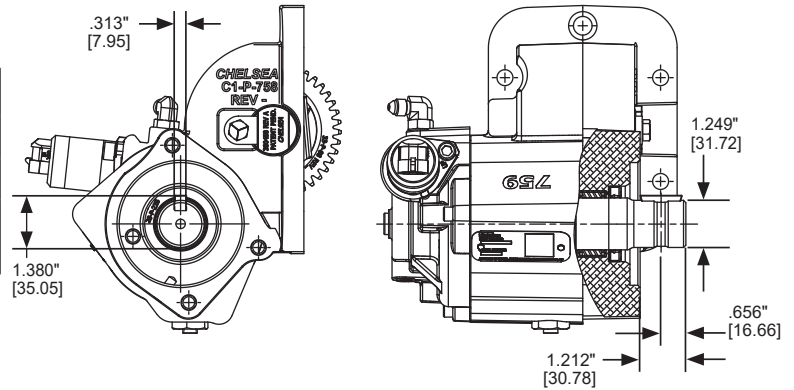

Option Code – XD	
Type	Direct Mount
Shaft	1" Rd. w/ 1/4" Key
PTO Series: 272, 272-FORD, †272U, 282	

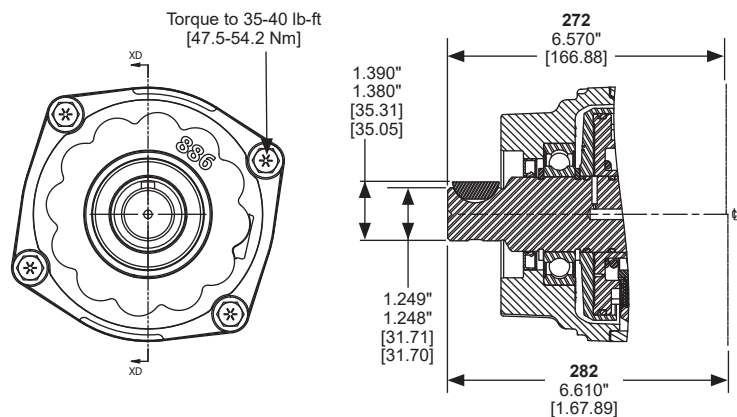

Flanges

† Coming Soon

* Recommended Grease: Texaco Coupling Grease, Code 1912 or Equivalent

NOTE: PUMP INSTALLATION PRECAUTIONS

Pump support brackets may be required - see General Safety information section for pump support bracket requirements. Also remember to pack the female PTO shaft with grease before installing the pump to the PTO.

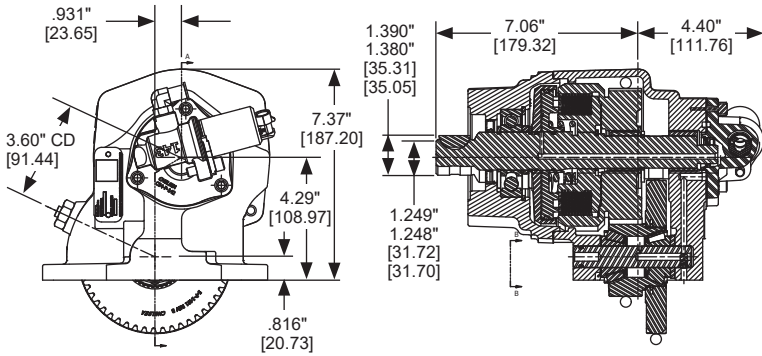

Option Code – XD	
Type	Direct Mount
Shaft	1" Rd. w/ 1/4" Key
PTO Series: 280	

Flanges

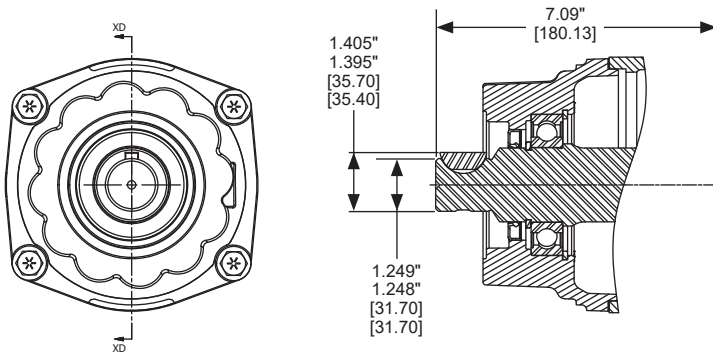

Option Code – XD	
Type	Direct Mount
Shaft	1" Rd. w/ 1/4" Key
PTO Series: 287	

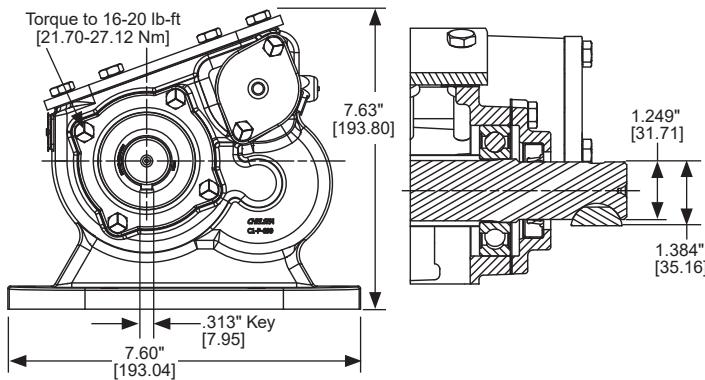

Option Code – XD	
Type	Direct Mount
Shaft	1" Rd. w/ 1/4" Key
PTO Series: 340, 348	

* Recommended Grease: Texaco Coupling Grease, Code 1912 or Equivalent

NOTE: PUMP INSTALLATION PRECAUTIONS

Pump support brackets may be required - see General Safety information section for pump support bracket requirements. Also remember to pack the female PTO shaft with grease before installing the pump to the PTO.

Option Code – XE	
Type	Direct Mount
Shaft	SAE A (5/8" - 9T)
Flange	SAE A 2 or 4-Bolt
PTO Series: 221, 267, 442, 447, 489, 660, 680, 2442	

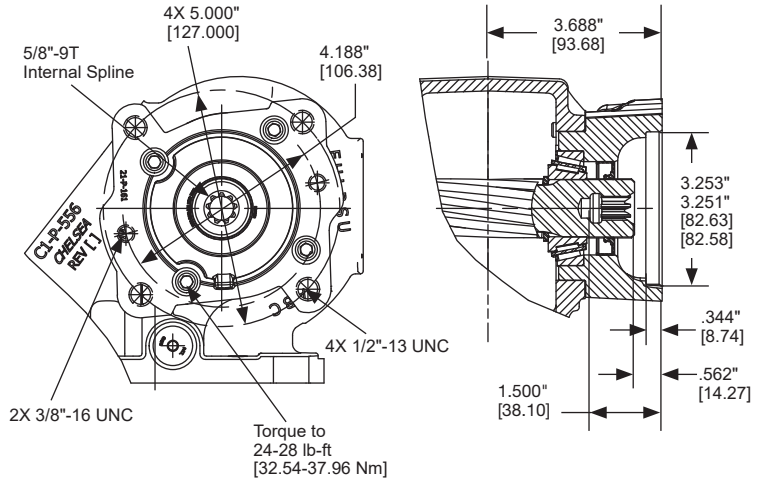

Option Code – XE	
Type	Direct Mount
Shaft	SAE A (5/8" - 9T)
Flange	SAE A 2 or 4-Bolt
PTO Series: 252	

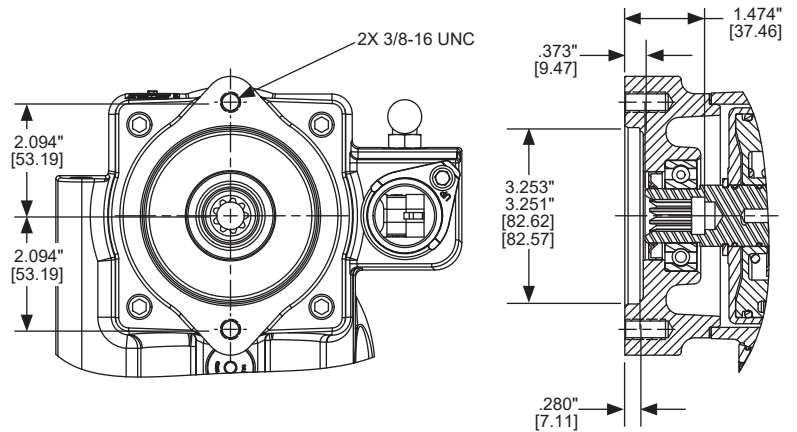

Option Code – XK	
Type	Direct Mount
Shaft	SAE B (7/8" - 13T)
Flange	SAE B 2 or 4-Bolt
PTO Series: 221, 267, 442, 447, 489, 660, 680, 680 DT12, 2442	

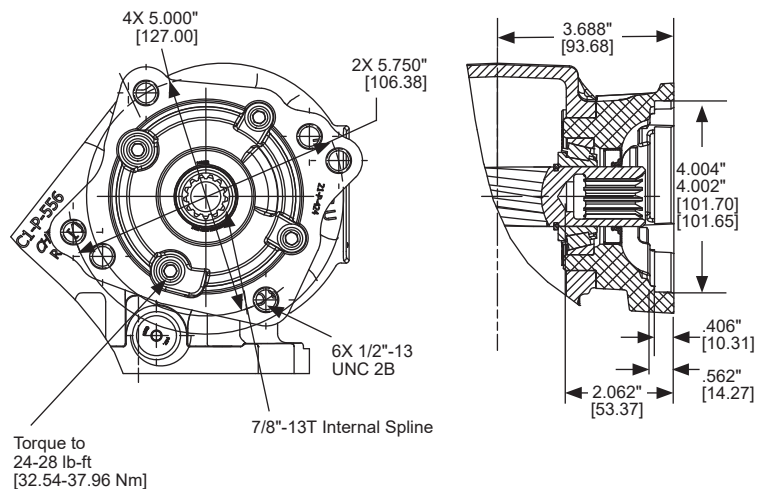

Flanges

NOTE: PUMP INSTALLATION PRECAUTIONS

Pump support brackets may be required - see General Safety information section for pump support bracket requirements. Also remember to pack the female PTO shaft with grease before installing the pump to the PTO.

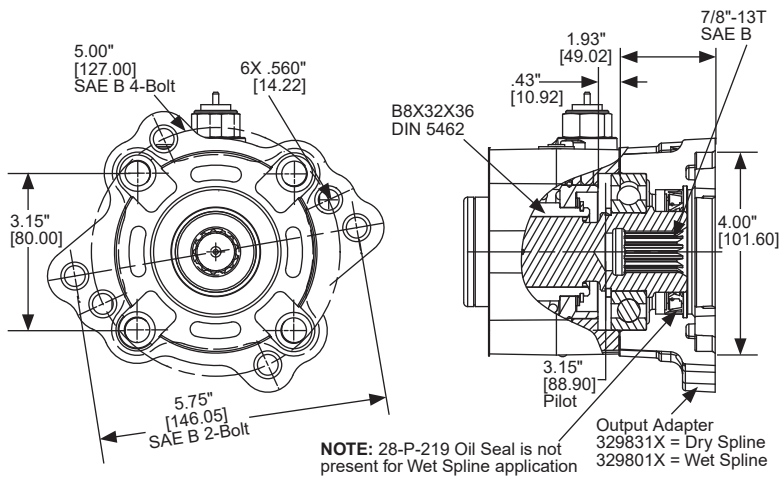

Option Code – XK	
Type	Direct Mount
Shaft	SAE B (7/8" - 13T)
Flange	SAE B 2 or 4-Bolt
PTO Series: 511	

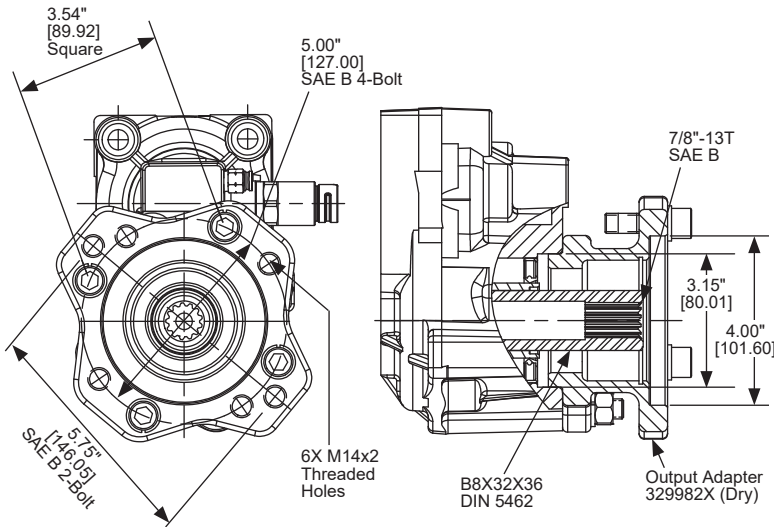

Option Code – XK	
Type	Direct Mount
Shaft	SAE B (7/8" - 13T)
Flange	SAE B 2 or 4-Bolt
PTO Series: 524	

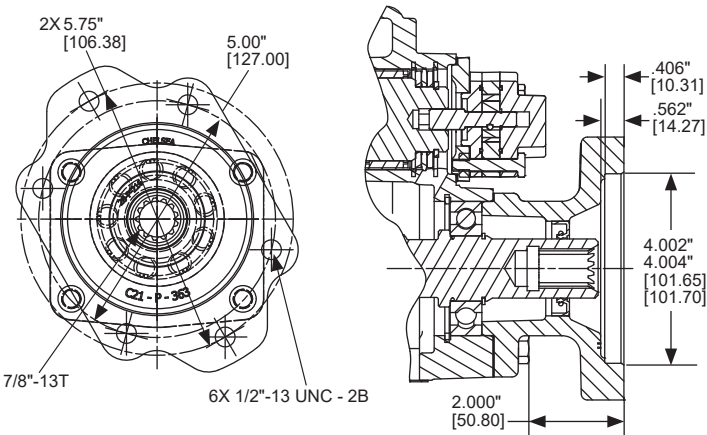

Option Code – XK	
Type	Direct Mount
Shaft	SAE B (7/8" - 13T)
Flange	SAE B 2 or 4-Bolt
PTO Series: 541	

NOTE: PUMP INSTALLATION PRECAUTIONS

Pump support brackets may be required - see General Safety information section for pump support bracket requirements. Also remember to pack the female PTO shaft with grease before installing the pump to the PTO.

Option Code – XK	
Type	Direct Mount
Shaft	SAE B (7/8" - 13T)
Flange	SAE B 2 or 4-Bolt
PTO Series: 880, 880 DT12	

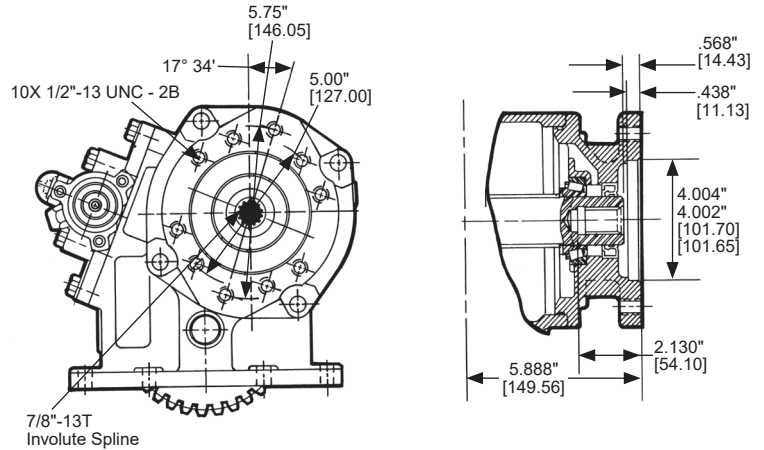

Option Code – XK	
Type	Direct Mount
Shaft	SAE B (7/8" - 13T)
Flange	SAE B 2 or 4-Bolt
PTO Series: 890, 892, 897, 899	

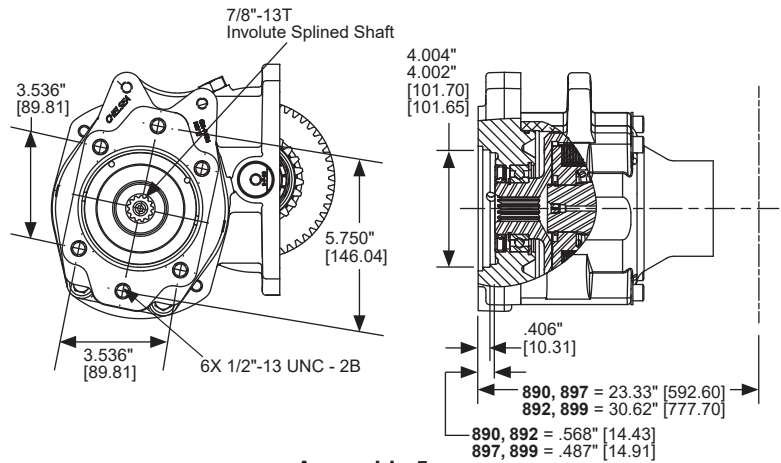

Assembly 5

Flanges

Option Code – XK	
Type	Direct Mount
Shaft	SAE B (7/8" - 13T)
Flange	SAE B 2 or 4-Bolt
PTO Series: 901	

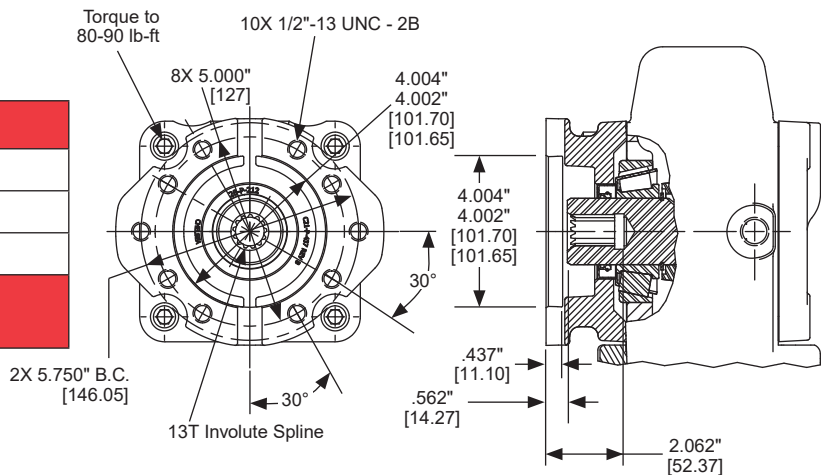

NOTE: PUMP INSTALLATION PRECAUTIONS

Pump support brackets may be required - see General Safety information section for pump support bracket requirements. Also remember to pack the female PTO shaft with grease before installing the pump to the PTO.

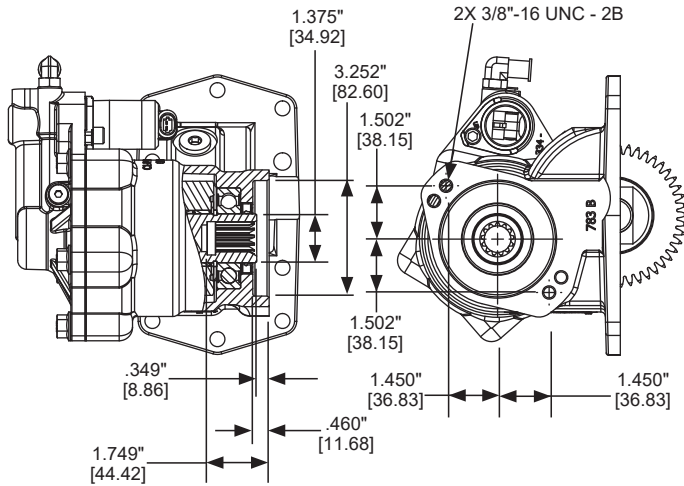

Option Code – XP	
Type	Direct Mount
Shaft	SAE B (7/8" - 13T)
Flange	SAE A 2-Bolt
PTO Series: 210	

Flanges

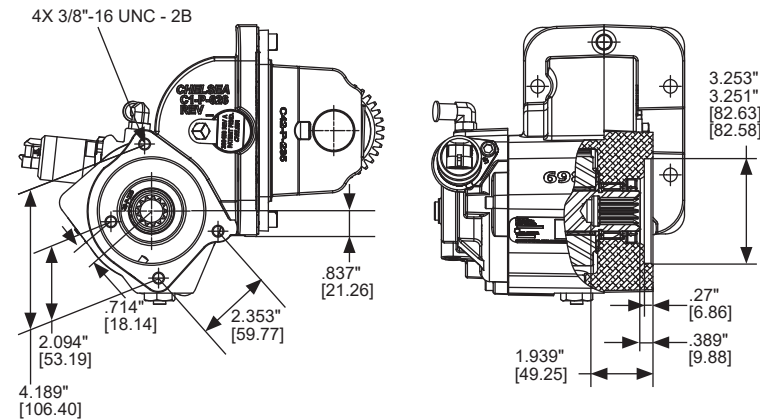

Option Code – XP	
Type	Direct Mount
Shaft	SAE B (7/8" - 13T)
Flange	SAE A 2-Bolt
PTO Series: 249	

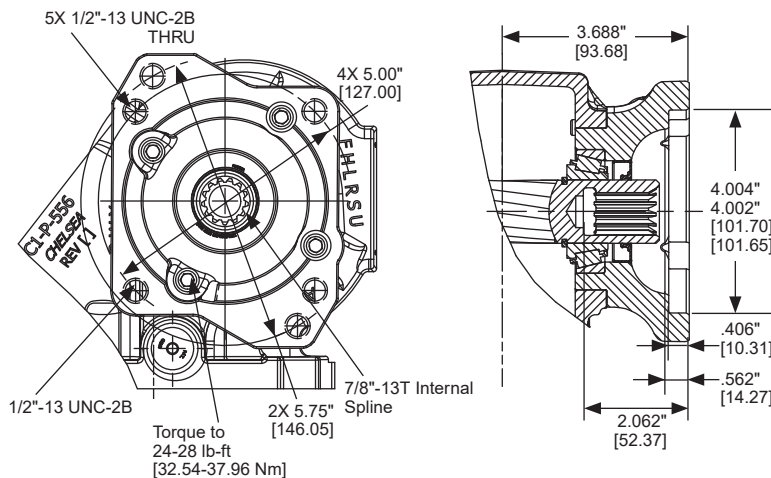

Option Code – XQ	
Type	Direct Mount
Shaft	SAE B (7/8" - 13T)
Flange	SAE B 2 or 4-Bolt
PTO Series: 221, 267, 442, 447, 489, 660, 680, 2442	

* Recommended Grease: Texaco Coupling Grease, Code 1912 or Equivalent

NOTE: PUMP INSTALLATION PRECAUTIONS

Pump support brackets may be required - see General Safety information section for pump support bracket requirements. Also remember to pack the female PTO shaft with grease before installing the pump to the PTO.

Option Code – XR	
Type	Direct Mount
Shaft	SAE B (7/8" - 13T)
Flange	Chelsea Special (Cloverleaf)
For Parker P16 S Flange Pumps	
PTO Series: 221, 267, 442, 447, 489, 660, 680, 2442	

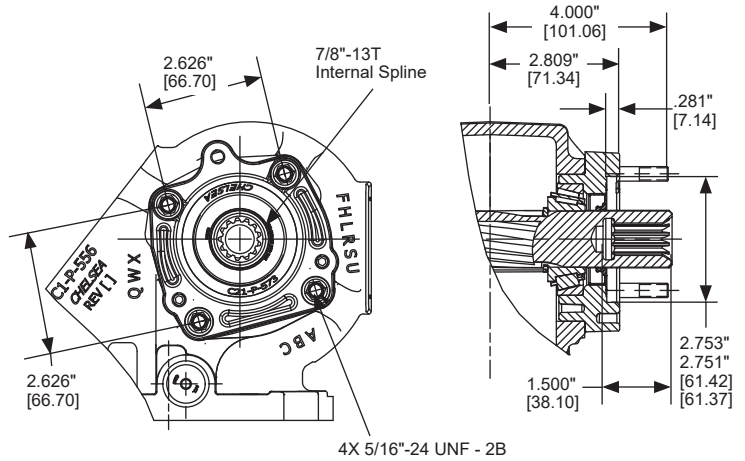

Option Code – XR	
Type	Direct Mount
Shaft	SAE B (7/8" - 13T)
Flange	Chelsea Special (Cloverleaf)
For Parker P16 S Flange Pumps	
PTO Series: 272, 272-FORD, 282	

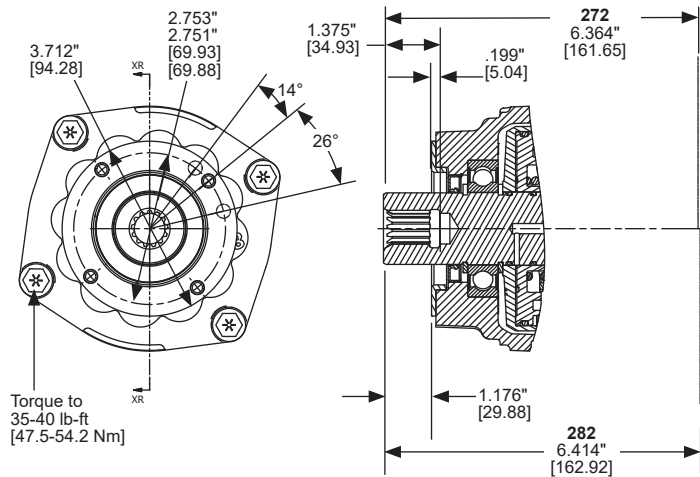

Option Code – XR	
Type	Direct Mount
Shaft	SAE B (7/8" - 13T)
Flange	Chelsea Special (Cloverleaf)
For Parker P16 S Flange Pumps	
PTO Series: 280	

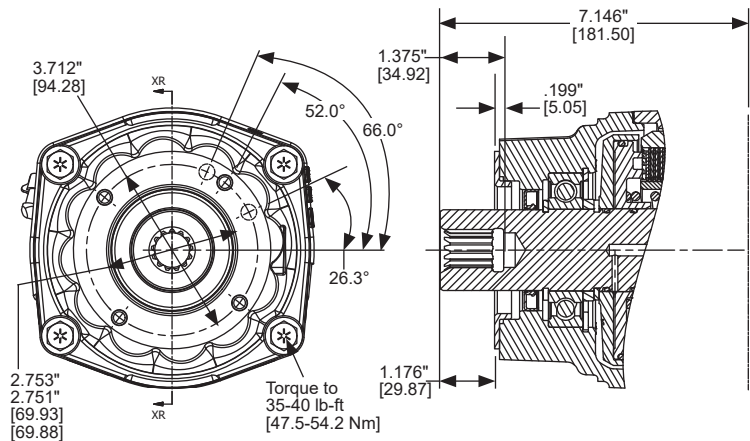

Flanges

* Recommended Grease: Texaco Coupling Grease, Code 1912 or Equivalent

NOTE: PUMP INSTALLATION PRECAUTIONS

Pump support brackets may be required - see General Safety information section for pump support bracket requirements. Also remember to pack the female PTO shaft with grease before installing the pump to the PTO.

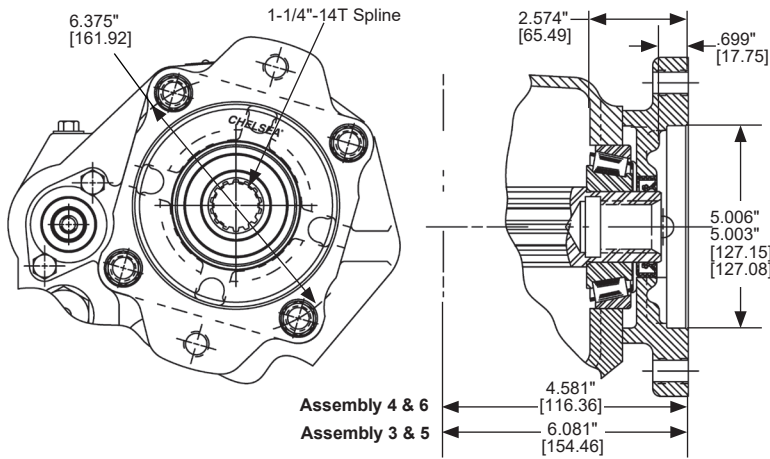

Option Code – XS	
Type	Direct Mount
Shaft	SAE C (1-1/4" - 14T)
Flange	SAE C 4-Bolt
PTO Series: 823, 823 DT12	

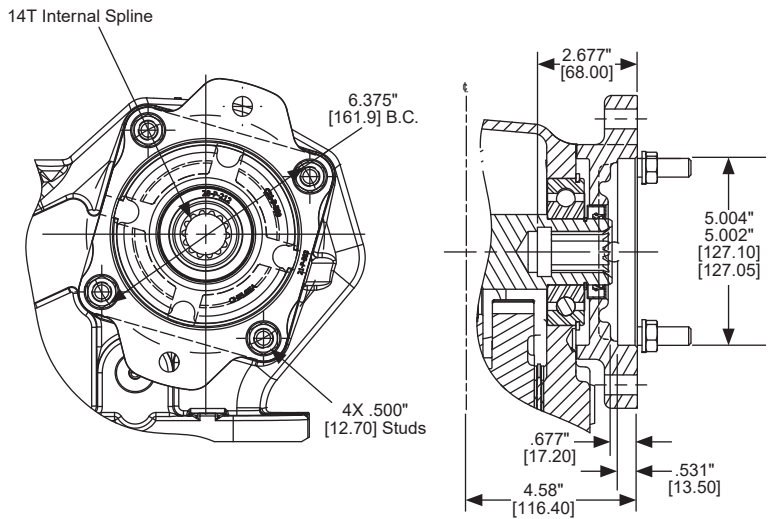

Option Code – XS	
Type	Direct Mount
Shaft	SAE C (1-1/4" - 14T)
Flange	SAE C 4-Bolt
PTO Series: 852	

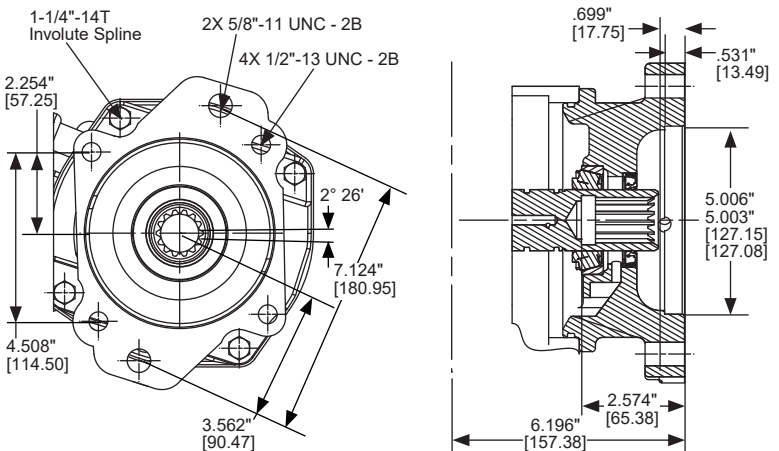

Option Code – XS	
Type	Direct Mount
Shaft	SAE C (1-1/4" - 14T)
Flange	SAE C 2 or 4-Bolt
PTO Series: 885	

* Recommended Grease: Texaco Coupling Grease, Code 1912 or Equivalent

NOTE: PUMP INSTALLATION PRECAUTIONS

Pump support brackets may be required - see General Safety information section for pump support bracket requirements. Also remember to pack the female PTO shaft with grease before installing the pump to the PTO.

Flanges

Option Code – XS	
Type	Direct Mount
Shaft	SAE C (1-1/4" - 14T)
Flange	SAE C 2 or 4-Bolt
PTO Series: 880, 880 DT12	

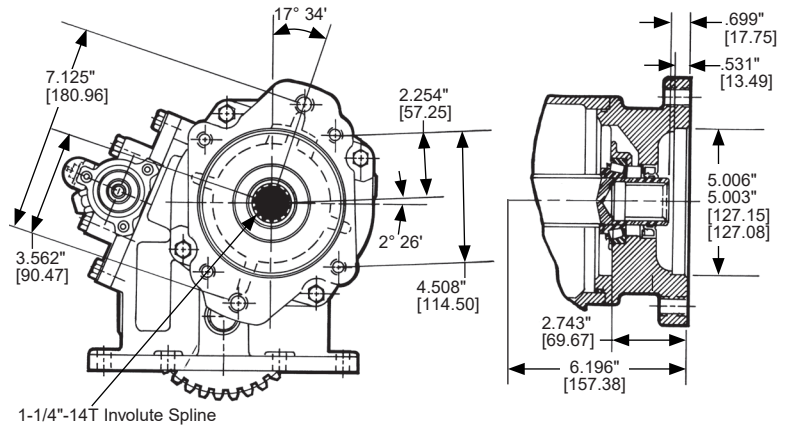

Option Code – XS	
Type	Direct Mount
Shaft	SAE C (1-1/4" - 14T)
Flange	SAE C 2 or 4-Bolt
PTO Series: 890, 892, 897, 899	

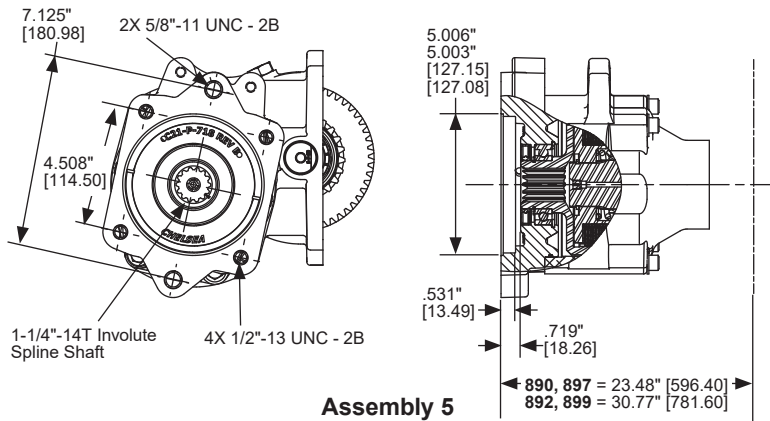

Assembly 5

Flanges

Option Code – XS	
Type	Direct Mount
Shaft	SAE C (1-1/4" - 14T)
Flange	SAE C 4-Bolt
PTO Series: 901	

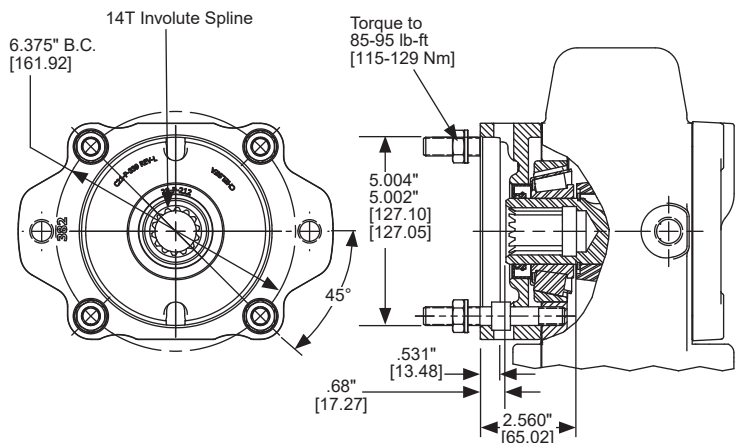

* Recommended Grease: Texaco Coupling Grease, Code 1912 or Equivalent

NOTE: PUMP INSTALLATION PRECAUTIONS

Pump support brackets may be required - see General Safety information section for pump support bracket requirements. Also remember to pack the female PTO shaft with grease before installing the pump to the PTO.

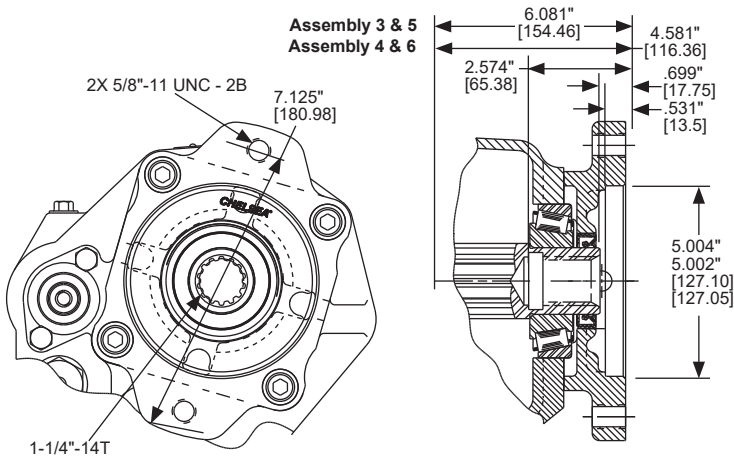

Option Code – XU	
Type	Direct Mount
Shaft	SAE C (1-1/4" - 14T)
Flange	SAE C 2-Bolt
PTO Series: 823, 823 DT12	

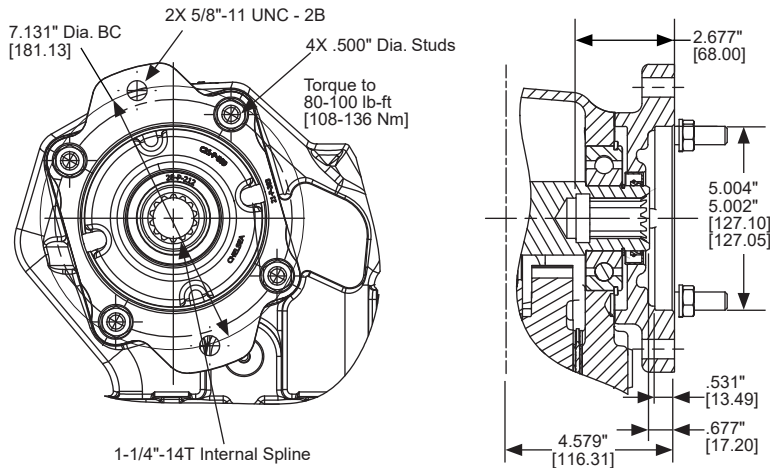

Option Code – XU	
Type	Direct Mount
Shaft	SAE C (1-1/4" - 14T)
Flange	SAE C 2-Bolt
PTO Series: 852	

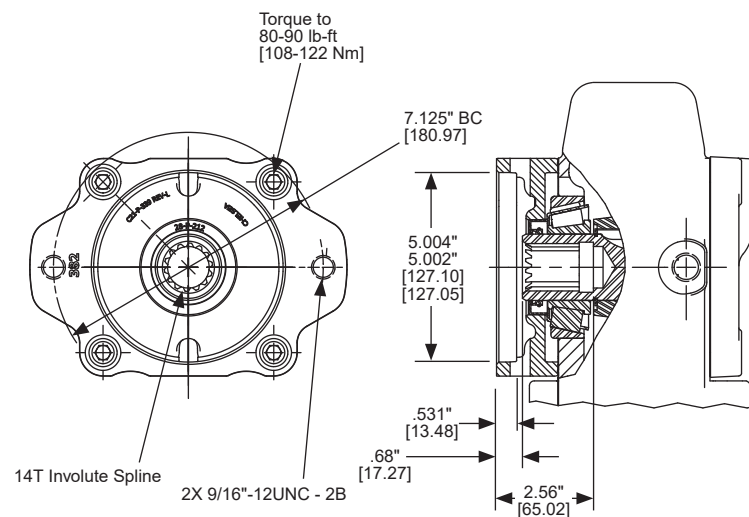

Option Code – XU	
Type	Direct Mount
Shaft	SAE C (1-1/4" - 14T)
Flange	SAE C 2-Bolt
PTO Series: 901	

* Recommended Grease: Texaco Coupling Grease, Code 1912 or Equivalent

NOTE: PUMP INSTALLATION PRECAUTIONS

Pump support brackets may be required - see General Safety information section for pump support bracket requirements. Also remember to pack the female PTO shaft with grease before installing the pump to the PTO.

Option Code – XV	
Type	Remote Mount
Shaft	1410 Companion Flange
PTO Series: 272, 272-FORD, †272U, 282	

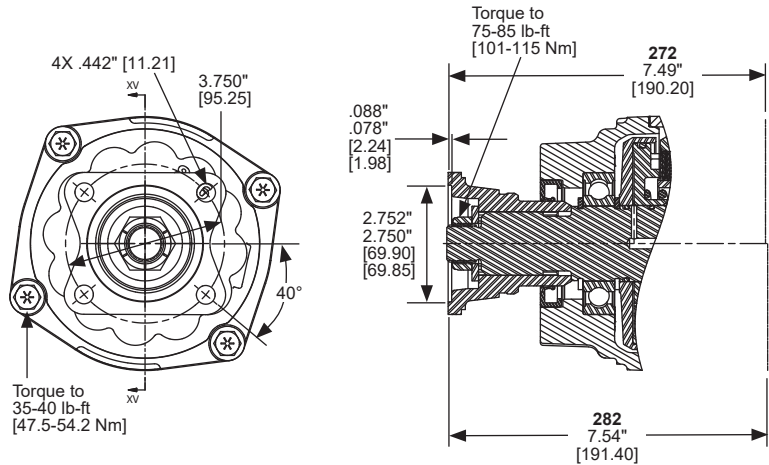

† Coming Soon

Option Code – XV	
Type	Remote Mount
Shaft	1410 Companion Flange
PTO Series: 280, 287	

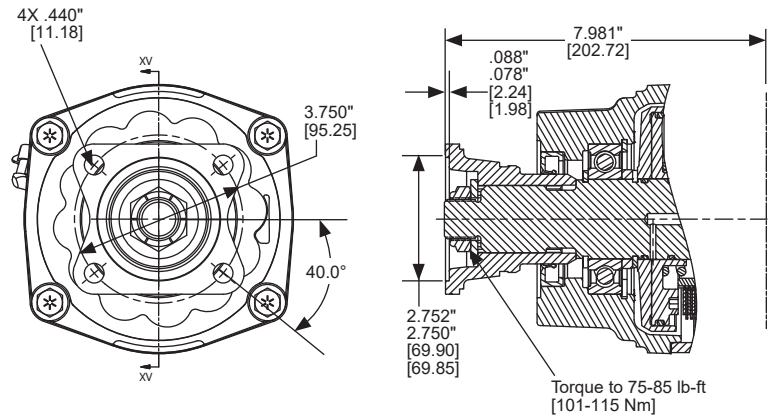

Flanges

Option Code – XV	
Type	Remote Mount
Shaft	1410 Companion Flange
PTO Series: 489 DT12	

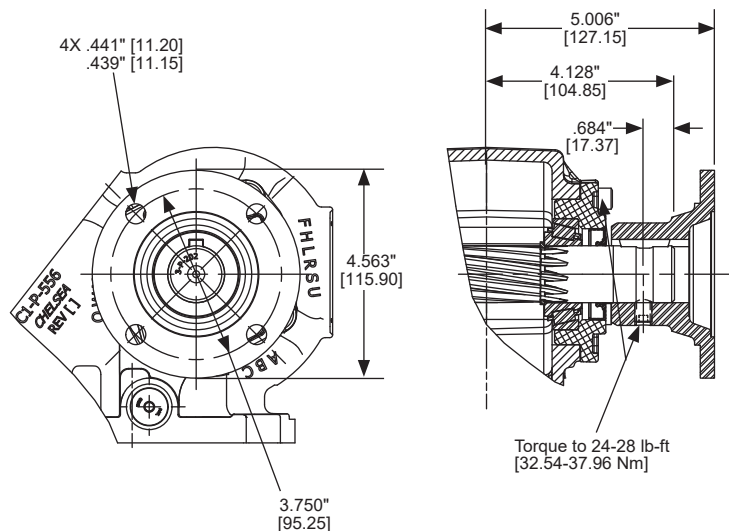

* Recommended Grease: Texaco Coupling Grease, Code 1912 or Equivalent

NOTE: PUMP INSTALLATION PRECAUTIONS

Pump support brackets may be required - see General Safety information section for pump support bracket requirements. Also remember to pack the female PTO shaft with grease before installing the pump to the PTO.

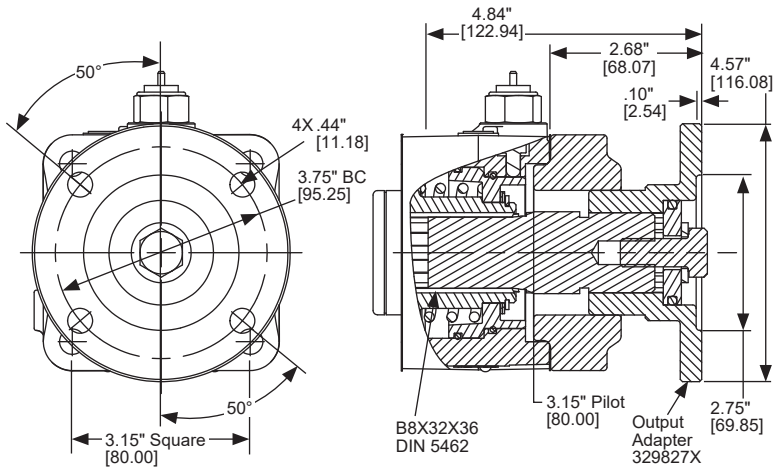

Option Code – XV	
Type	Remote Mount
Shaft	1410 Companion Flange
PTO Series: 511	

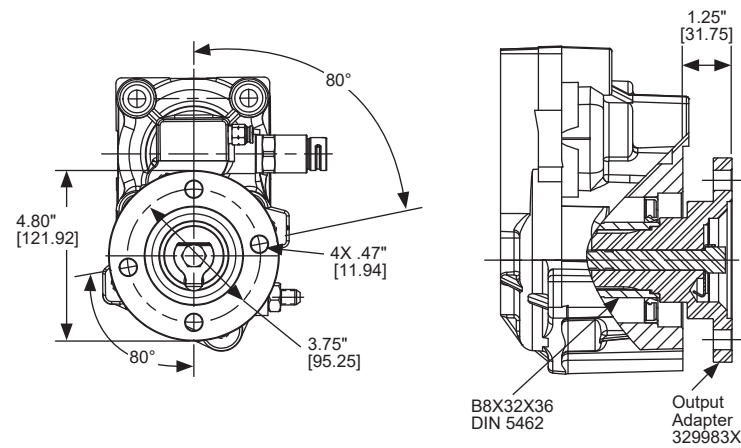

Option Code – XV	
Type	Remote Mount
Shaft	1410 Companion Flange
PTO Series: 524	

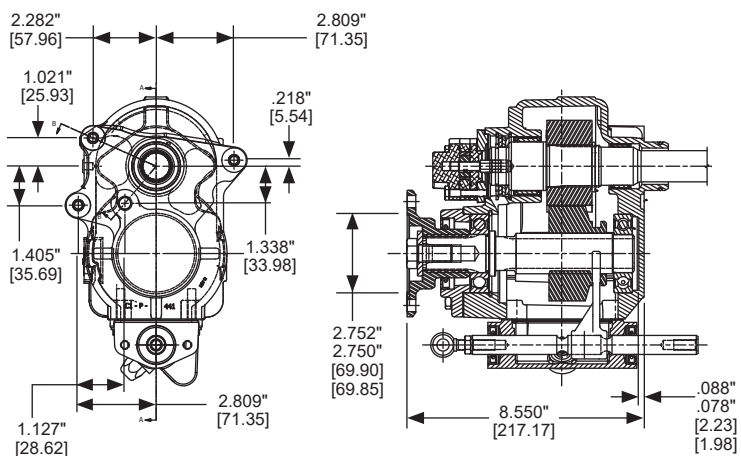

Option Code – XV	
Type	Remote Mount
Shaft	1410 Companion Flange
PTO Series: 541	

NOTE: PUMP INSTALLATION PRECAUTIONS

Pump support brackets may be required - see General Safety information section for pump support bracket requirements. Also remember to pack the female PTO shaft with grease before installing the pump to the PTO.

Option Code – XV	
Type	Remote Mount
Shaft	1350/1410 Companion Flange
PTO Series: 660, 680, 680 DT12	

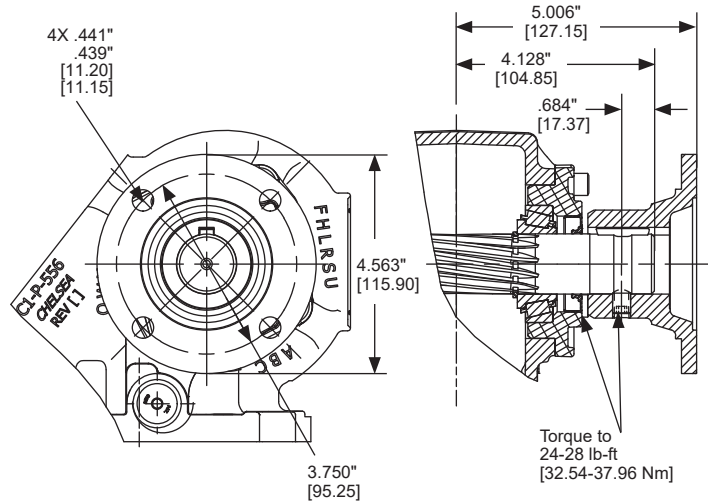

Option Code – XV	
Type	Remote Mount
Shaft	1410 Companion Flange
PTO Series: 823, 823 DT12, 863, 880, 880 DT12	

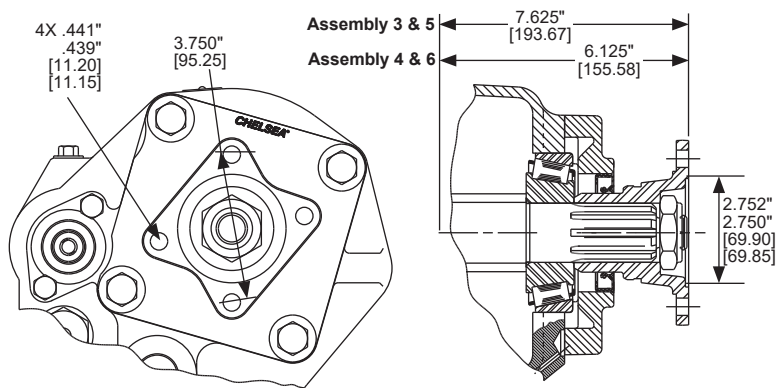

Option Code – XV	
Type	Remote Mount
Shaft	1410 Companion Flange
PTO Series: 852	

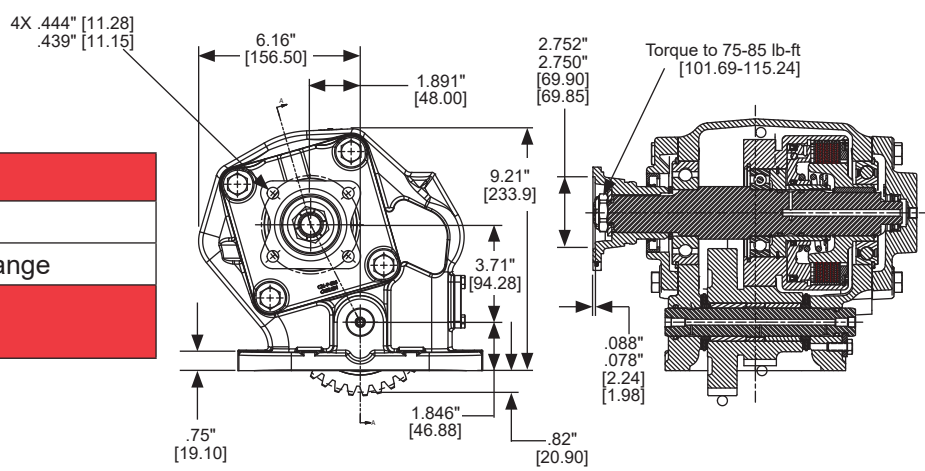

Flanges

NOTE: PUMP INSTALLATION PRECAUTIONS
Pump support brackets may be required - see General Safety information section for pump support bracket requirements. Also remember to pack the female PTO shaft with grease before installing the pump to the PTO.

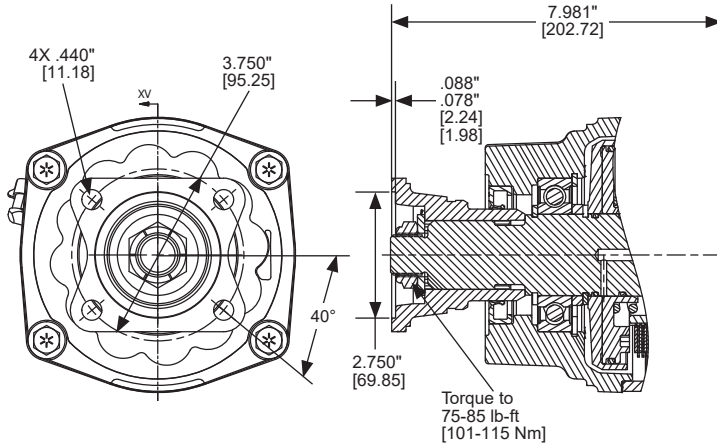

Option Code – XV	
Type	Remote Mount
Shaft	1410 Companion Flange
PTO Series: 870, 877	

Flanges

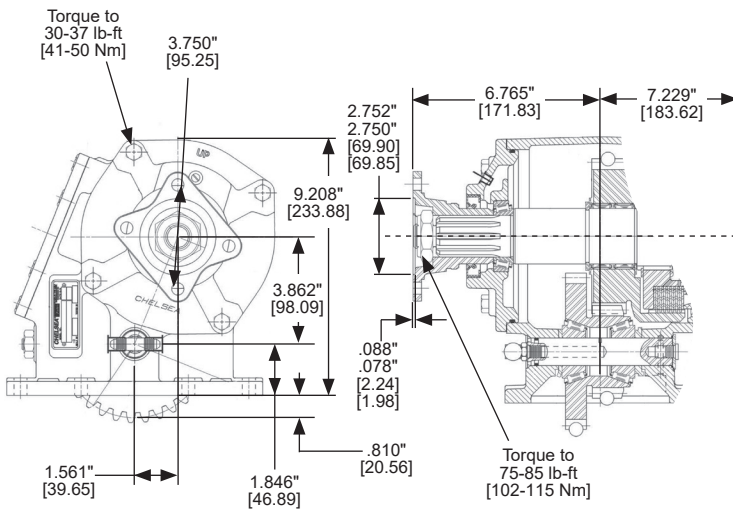

Option Code – XV	
Type	Remote Mount
Shaft	1410 Companion Flange
PTO Series: 885	

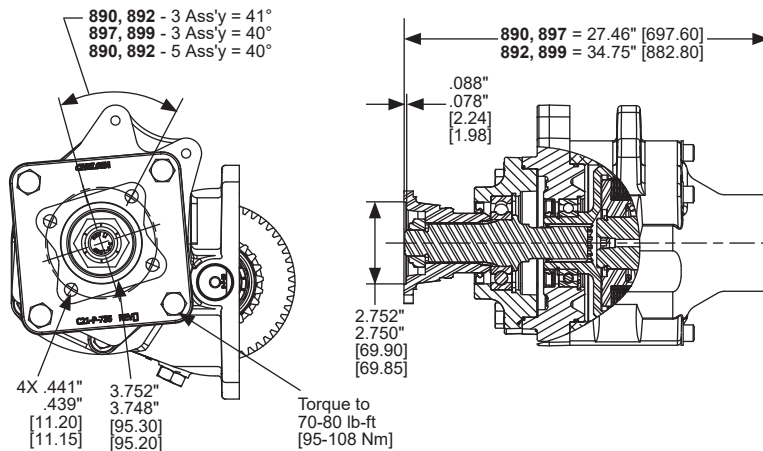

Option Code – XV	
Type	Remote Mount
Shaft	1410 Companion Flange
PTO Series: 890, 892, 897, 899	

* Recommended Grease: Texaco Coupling Grease, Code 1912 or Equivalent

NOTE: PUMP INSTALLATION PRECAUTIONS

Pump support brackets may be required - see General Safety information section for pump support bracket requirements. Also remember to pack the female PTO shaft with grease before installing the pump to the PTO.

Option Code – XV	
Type	Remote Mount
Shaft	1410 Companion Flange
PTO Series: 901	

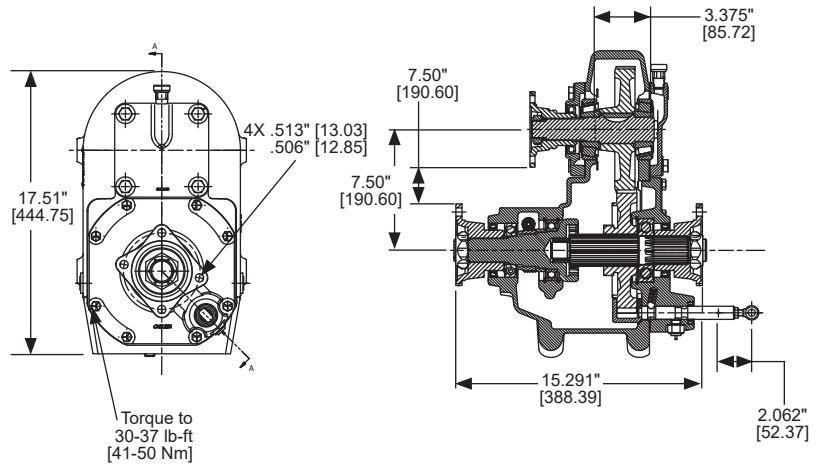

Option Code – XX	
Type	Remote Mount
Shaft	1-1/4" SAE Taper Shaft
PTO Series: 221, 267, 442, 447, 489, 660, 680, 2442	

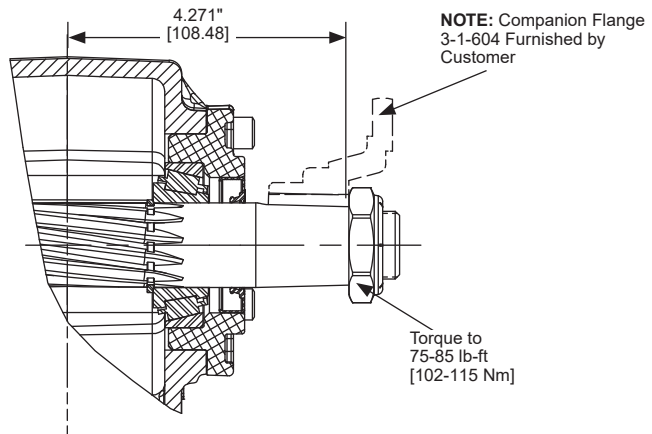

Option Code – XY	
Type	Direct Mount
Shaft	DIN 5462 (B8x32x36 - 8T)
Flange	ISO 7653 Pump Mount
PTO Series: 221, 267, 442, 447, 489, 489 DT12, 660, 680, 680 DT12, 2442	

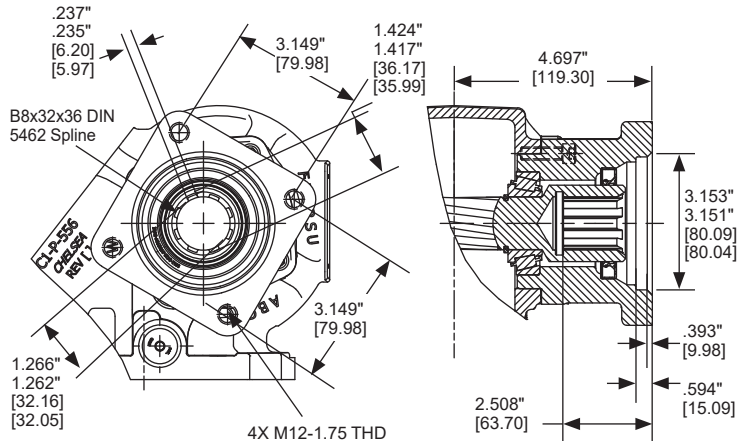

Flanges

* Recommended Grease: Texaco Coupling Grease, Code 1912 or Equivalent

NOTE: PUMP INSTALLATION PRECAUTIONS

Pump support brackets may be required - see General Safety information section for pump support bracket requirements. Also remember to pack the female PTO shaft with grease before installing the pump to the PTO.

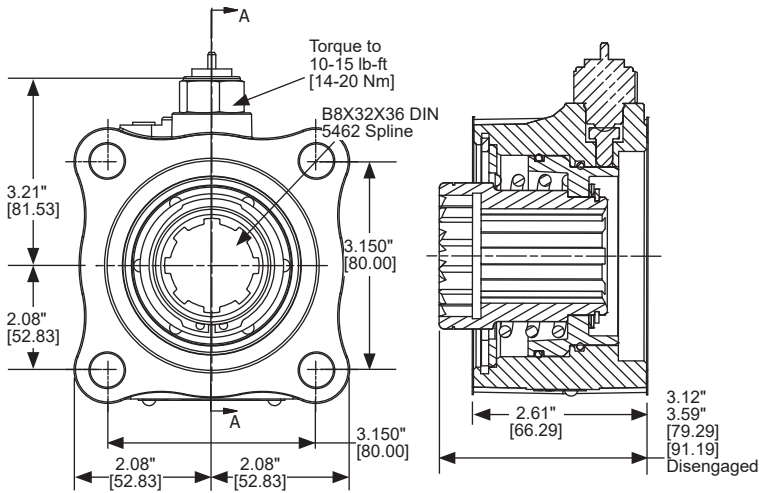

Option Code – XY	
Type	Direct Mount
Shaft	DIN 5462 (B8x32x36-8T)
Flange	ISO 7653 Pump Mount
PTO Series: 511	

Flanges

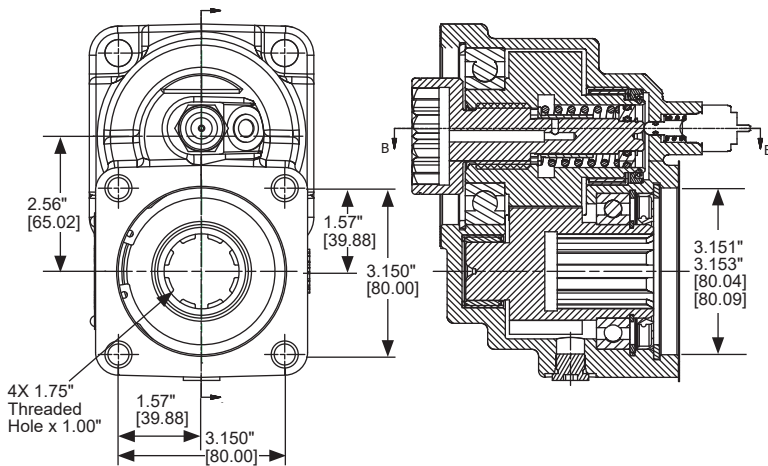

Option Code – XY	
Type	Direct Mount
Shaft	DIN 5462 (B8x32x36-8T)
Flange	ISO 7653 Pump Mount
PTO Series: 524	

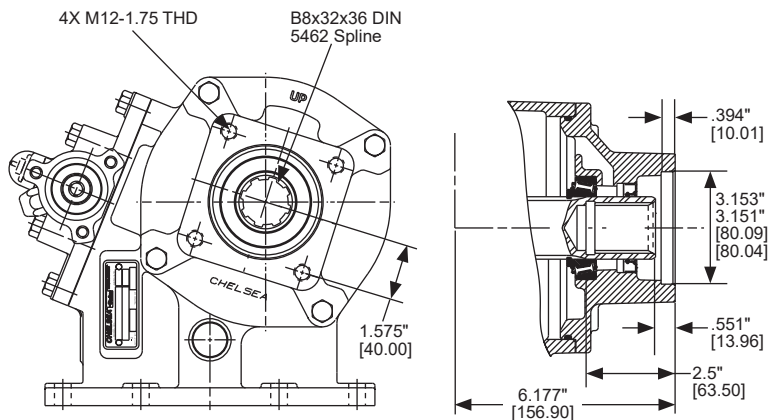

Option Code – XY	
Type	Direct Mount
Shaft	DIN 5462 (B8x32x36-8T)
Flange	ISO 7653 Pump Mount
PTO Series: 880, 880 DT12	

* Recommended Grease: Texaco Coupling Grease, Code 1912 or Equivalent

NOTE: PUMP INSTALLATION PRECAUTIONS

Pump support brackets may be required - see General Safety information section for pump support bracket requirements. Also remember to pack the female PTO shaft with grease before installing the pump to the PTO.

Option Code - XY	
Type	Direct Mount
Shaft	DIN 5462 (B8x32x36-8T)
Flange	ISO 7653 Pump Mount
PTO Series: 890, 892, 897, 899	

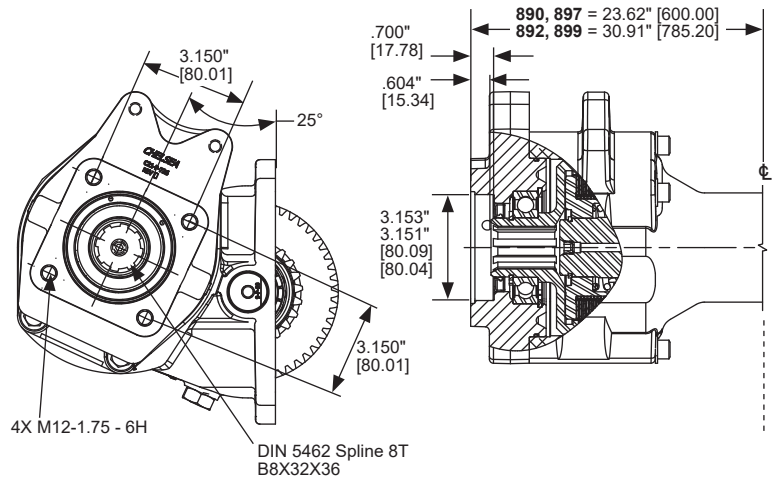

Option Code - ZS	
Type	Direct Mount
Shaft	SAE C (1-1/4" - 14T)
Flange	SAE C 4-Bolt
PTO Series: 890, 892, 897, 899	

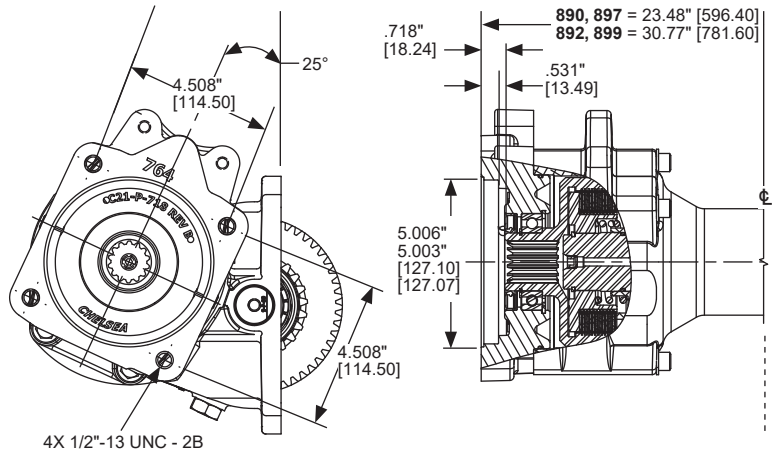

Option Code - 21-P-525	
Flange	SAE B 2 or 4-Bolt
(XR to XK Conversion Flange)	

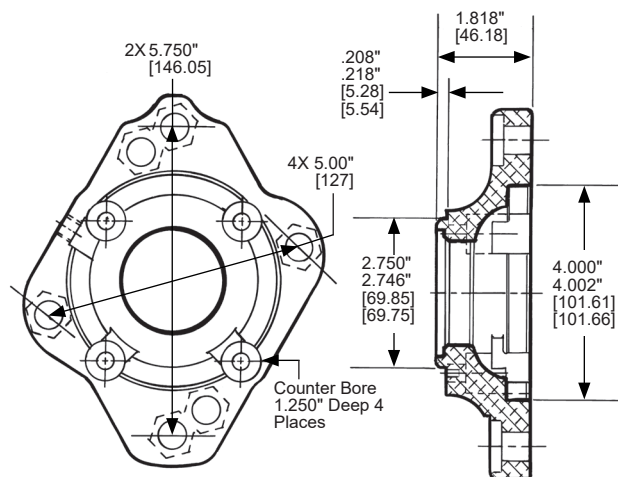

Flanges

* Recommended Grease: Texaco Coupling Grease, Code 1912 or Equivalent

NOTE: PUMP INSTALLATION PRECAUTIONS

Pump support brackets may be required - see General Safety information section for pump support bracket requirements. Also remember to pack the female PTO shaft with grease before installing the pump to the PTO.

NOTES

Flanges



ASSEMBLY OPTIONS

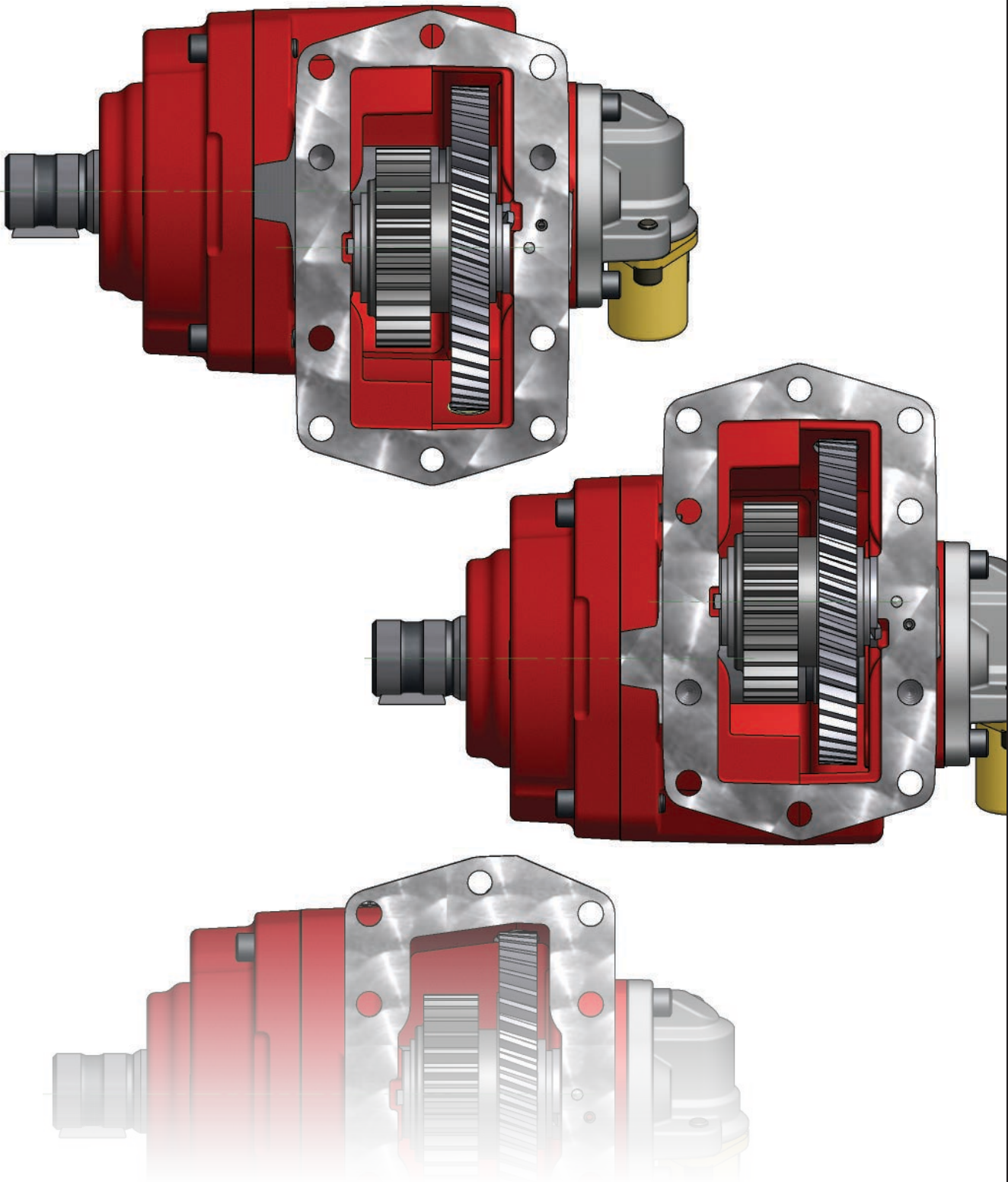

Service / Legacy PTO Assemblies 4.IV

210 Series 4.1

221 Series 4.2

249 Series 4.3

249V Series 4.4

252 Series 4.5

267 Series 4.6

272 Series 4.7

272-FORD Series 4.8

272U Series 4.9

280 Series 4.10

282 Series 4.11

287 Series 4.12

340 Series 4.13

348 Series 4.14

442 Series 4.15

447 Series 4.16

489 Series 4.17

489 Series For Detroit DT12™ 4.18

511 Series 4.19

524 Series 4.20

541 Series 4.21

660 Series 4.22

680 Series 4.23

680 Series For Detroit DT12™ 4.24

823 Series 4.25

823 Series For Detroit DT12™ 4.26

852 Series 4.27

863 Series 4.28

870 Series 4.29

870-XL Series 4.30

877 Series 4.31

877-XL Series 4.32

880 Series 4.33

880 Series For Detroit DT12™ 4.34

885 Series 4.35

890 Series 4.36

892 Series 4.37

897 Series 4.38

899 Series 4.39

901 Series 4.40

912 Series 4.41

2442 Series 4.42

626, 628, 630 and 645 Series 4.43

Assembly

Assembly Options**Service / Legacy PTO Assemblies**

The following PTO Series are still available thru a limited period to meet service requirements.

Please contact factory for price and lead times.

Product Series	Service
429 Series	2022
435 Series	2022
522 Series	2023
812 Series	2023
859 Series	2023
867 Series	2023
221*L Series	2026
230 Series	2026
231 Series	2026
236 Series	2026
238 Series	2026
270 Series	2026
271 Series	2026
277 Series	2026
278 Series	2026
CAT-D Series	2026
CAT-H Series	2026
247 Series	2028
352 Series	2028
560 Series	2028
941 Series	2028
290 Series	2029
590 Series	2030

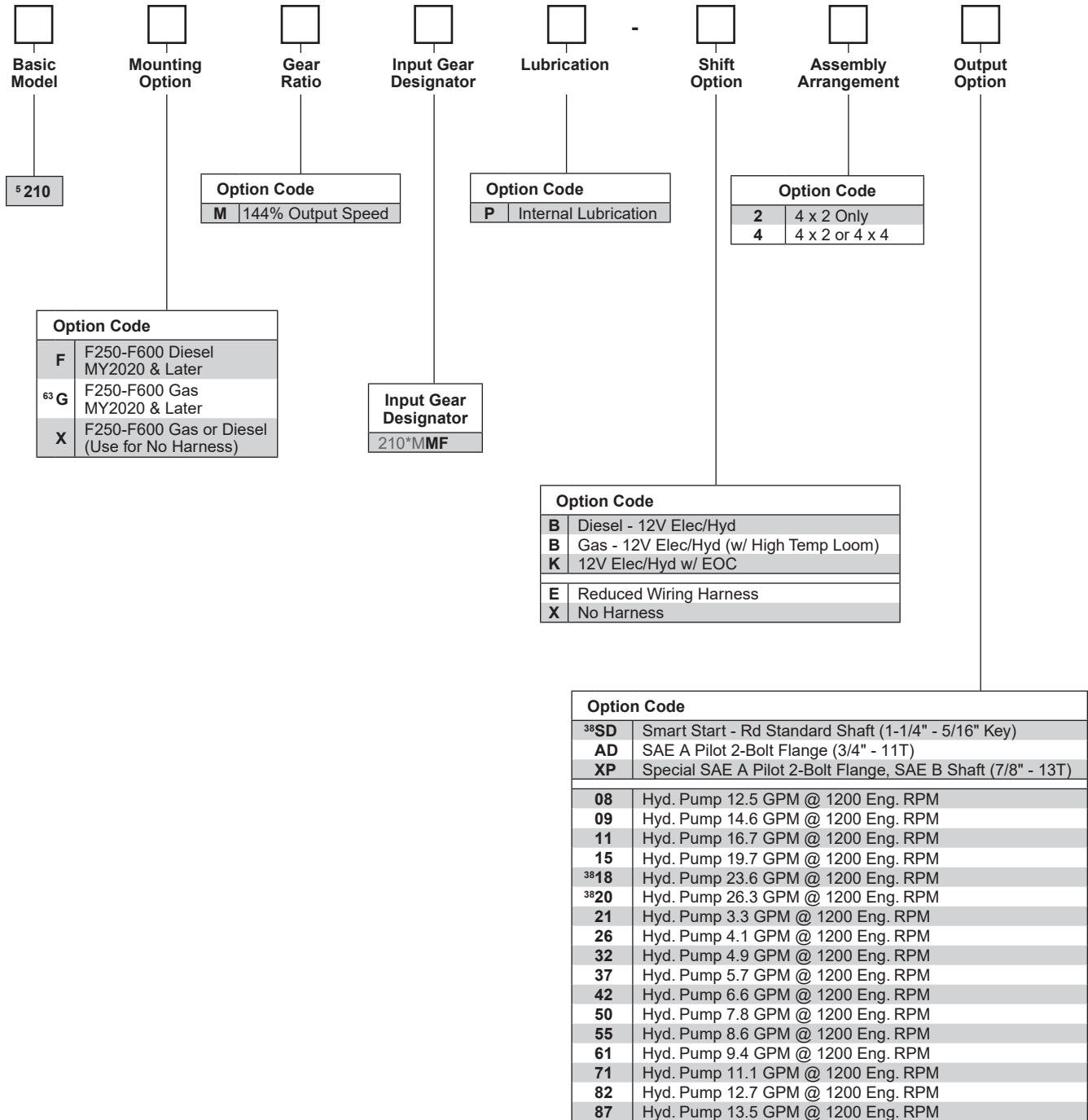

Assembly

⁵ Automatically pressure lubed

³⁸ 4 x 2 Vehicles only

⁶³ Includes wiring harness with high temperature loom and heat shield

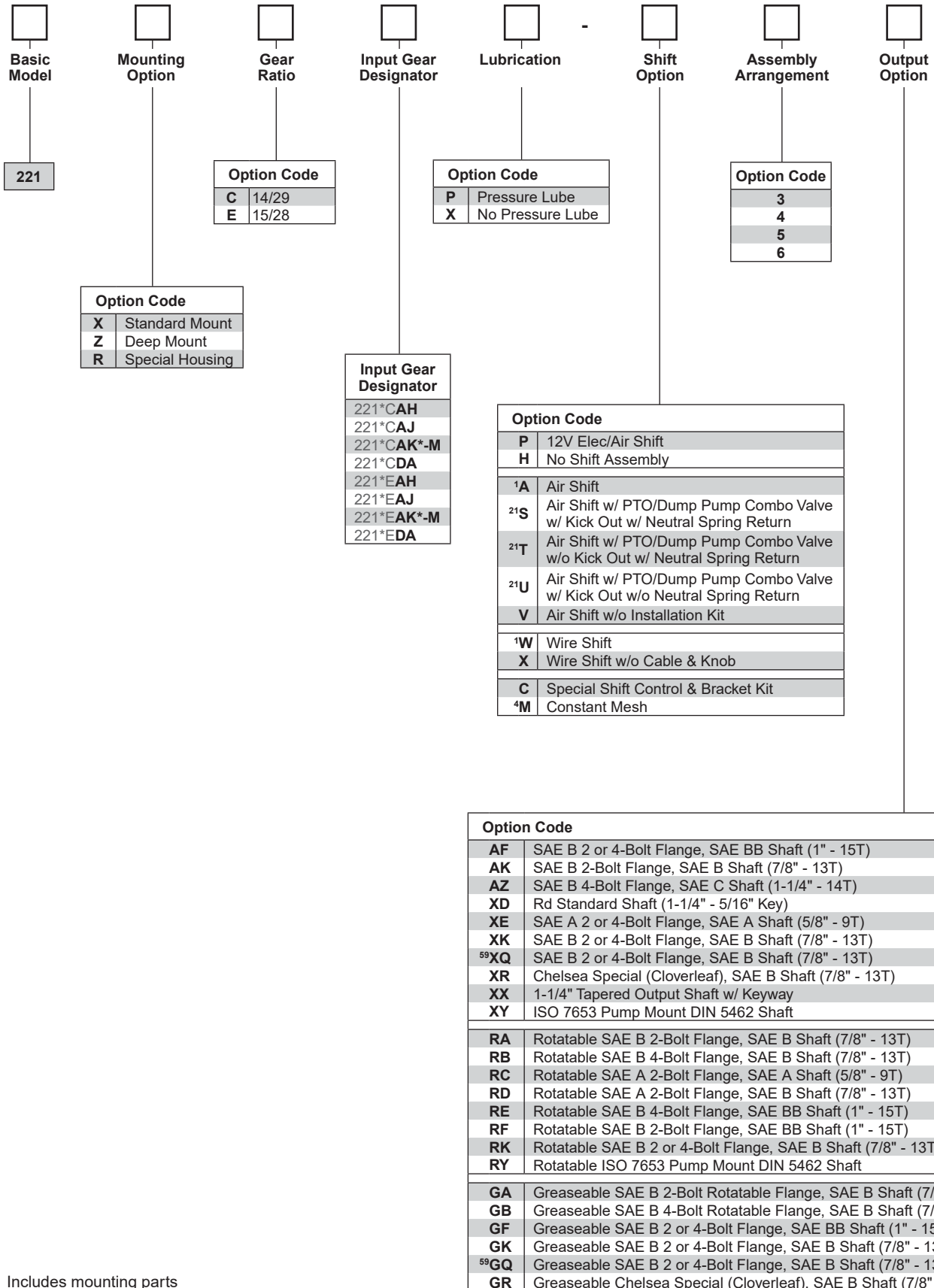

Assembly

¹ Includes mounting parts

⁴ Available only on 221*CAK and 221*EAK

²¹ Includes installation kit, console sold separately

⁵⁹ Same as XK except rotated 90°

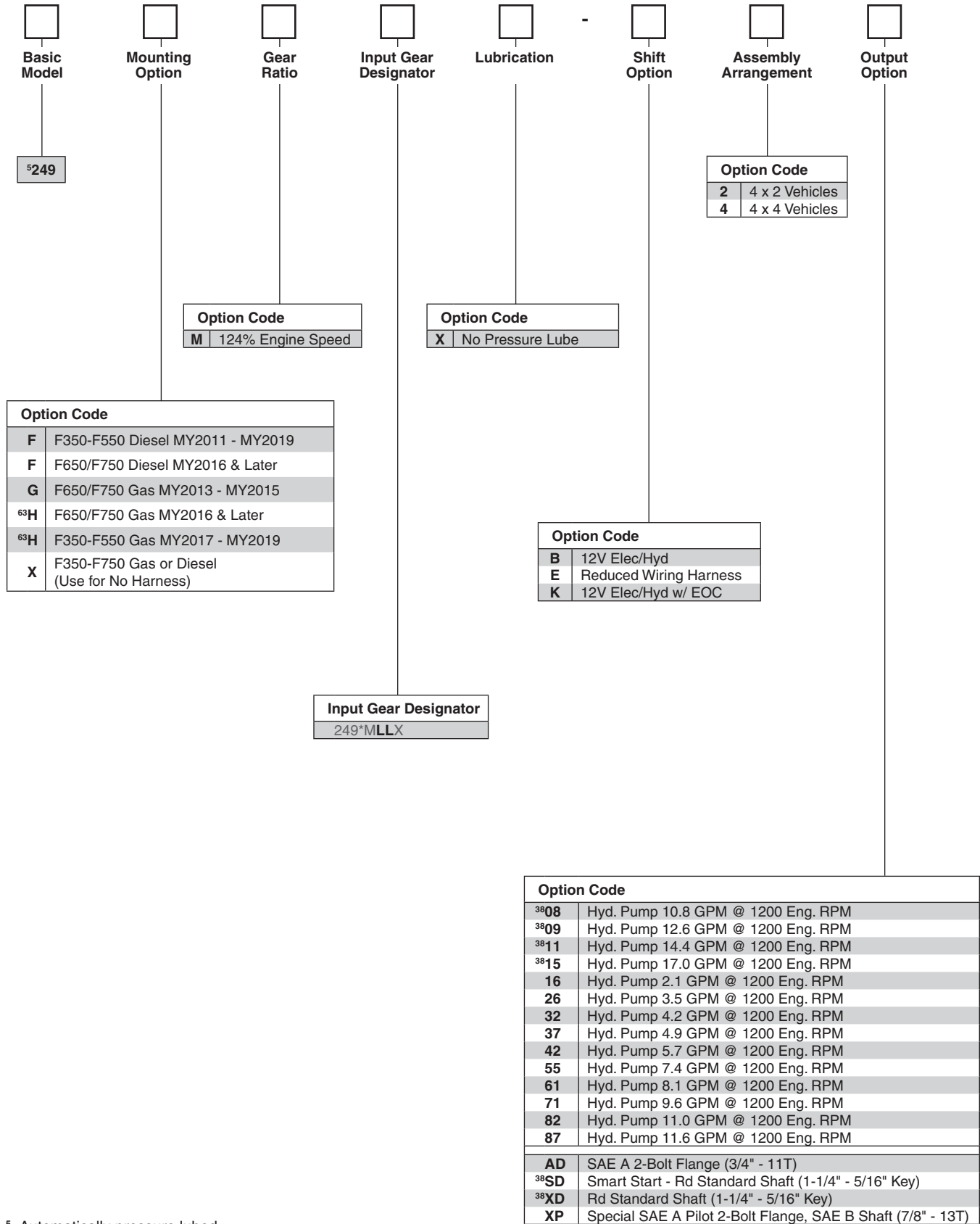

Assembly

⁵ Automatically pressure lubed

³⁸ 4 x 2 vehicles only

⁶³ Includes Wiring Harness with high temperature loom and Heat Shield

NOTE: Pump displacement is theoretical.

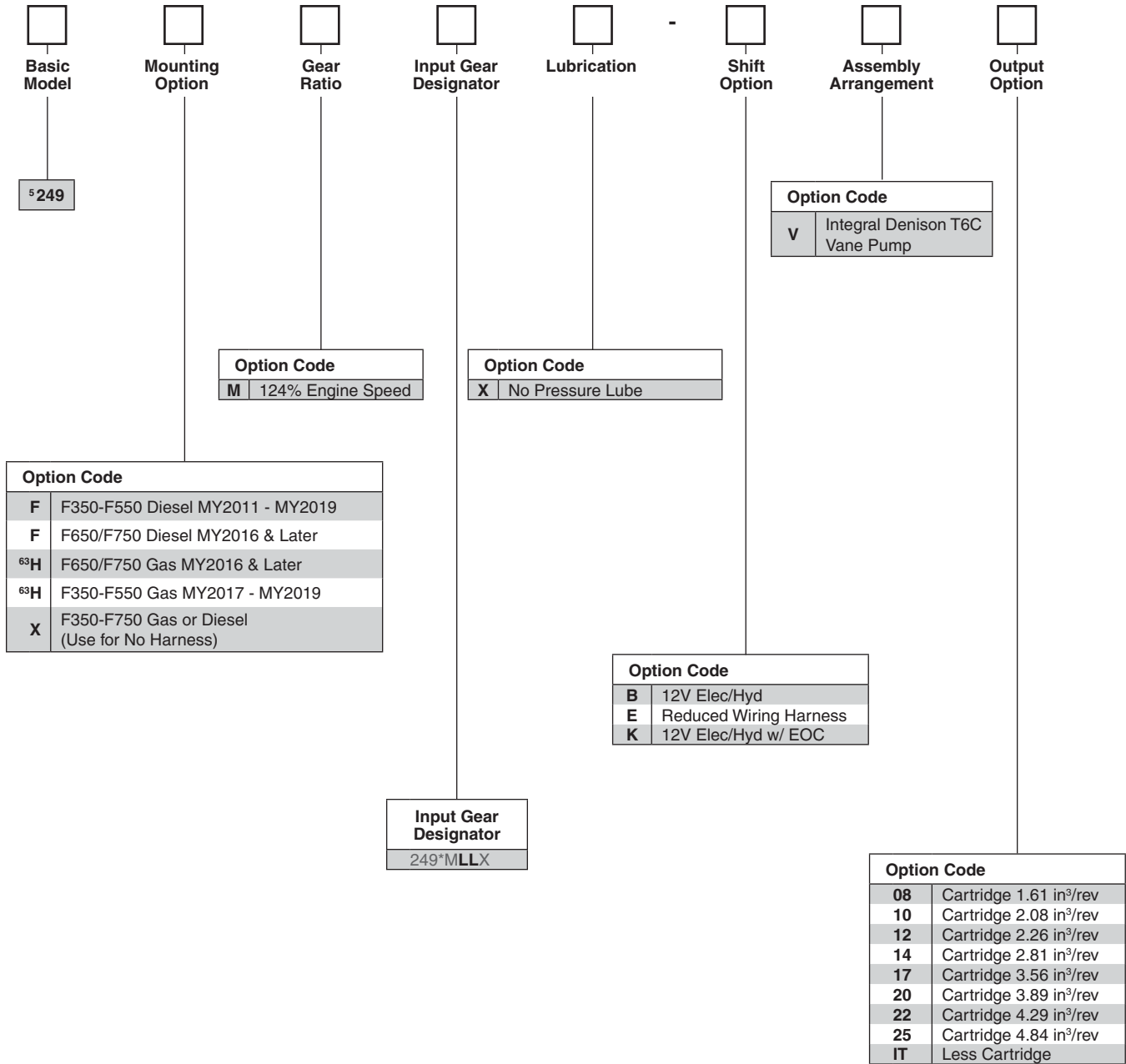

Assembly

⁵ Automatically pressure lubed

⁶³ Includes Wiring Harness with high temperature loom and Heat Shield

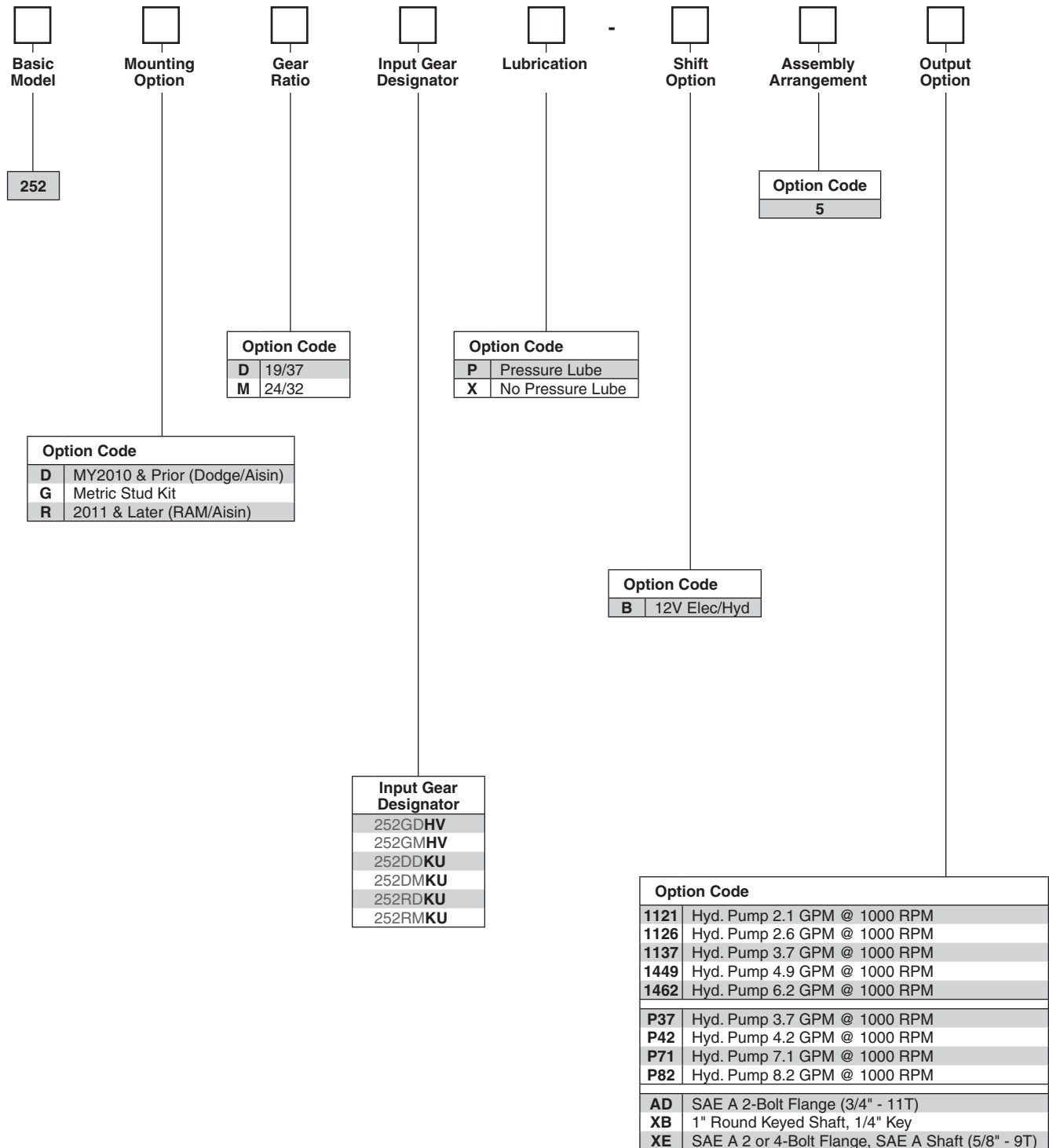

Assembly

NOTE: Pump displacement is theoretical.

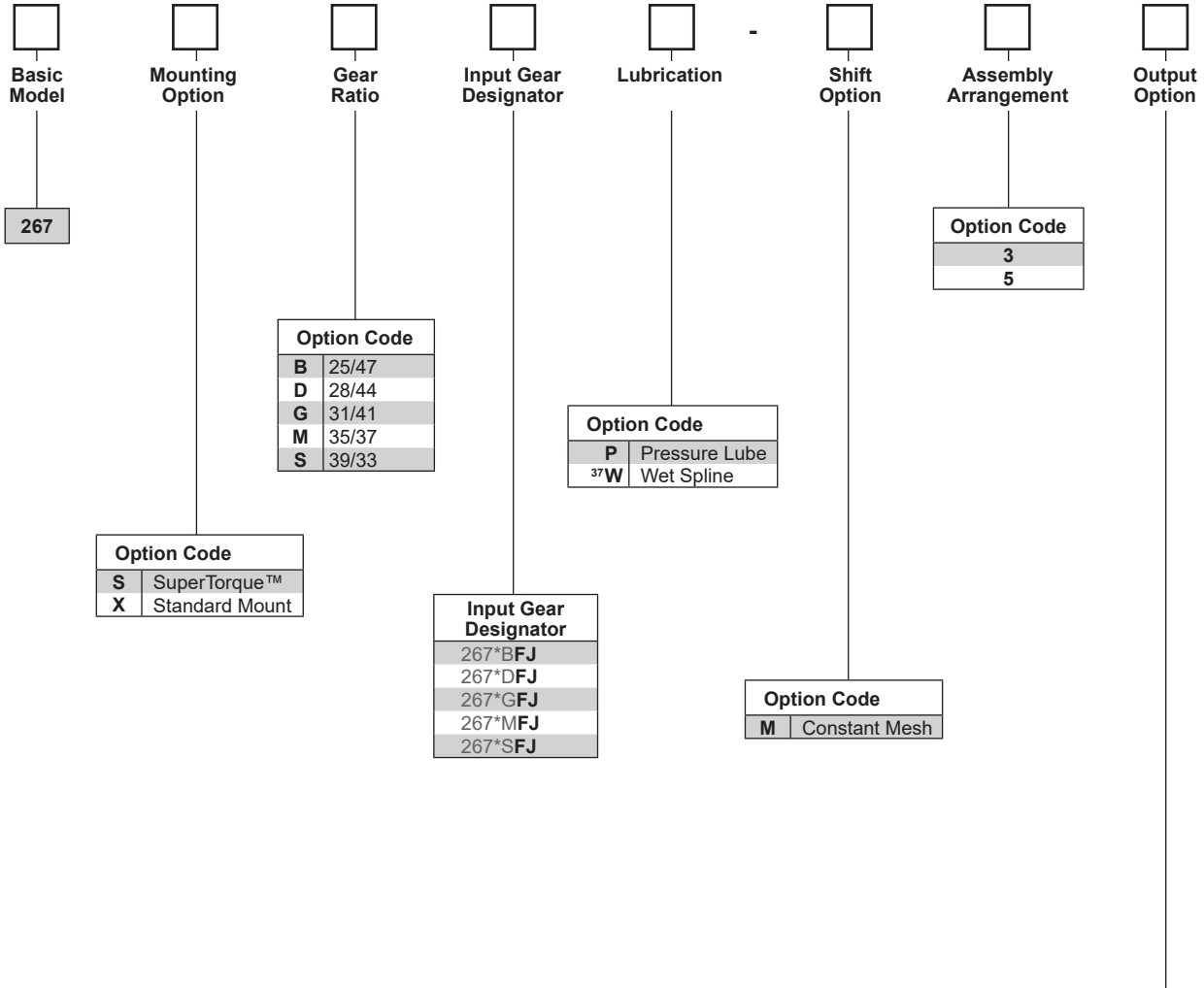

Option Code	
AF	SAE B 2 or 4-Bolt Flange, SAE BB Shaft (1" - 15T)
AK	SAE B 2-Bolt Flange, SAE B Shaft (7/8" - 13T)
AZ	SAE B 4-Bolt Flange, SAE C Shaft (1-1/4" - 14T)
XD	Rd Standard Shaft (1-1/4" - 5/16" Key)
XE	SAE A 2 or 4-Bolt Flange, SAE A Shaft (5/8" - 9T)
²³ XK	SAE B 2 or 4-Bolt Flange, SAE B Shaft (7/8" - 13T)
⁵⁹ XQ	SAE B 2 or 4-Bolt Flange, SAE B Shaft (7/8" - 13T)
XR	Chelsea Special (Cloverleaf), SAE B Shaft (7/8" - 13T)
¹³ XX	1-1/4" Tapered Output Shaft w/ Keyway
XY	ISO 7653 Pump Mount DIN 5462 Shaft
TV	Tapered Shaft 1410 Series Companion Flange
RA	Rotatable SAE B 2-Bolt Flange, SAE B Shaft (7/8" - 13T)
RB	Rotatable SAE B 4-Bolt Flange, SAE B Shaft (7/8" - 13T)
RC	Rotatable SAE A 2-Bolt Flange, SAE A Shaft (5/8" - 9T)
RD	Rotatable SAE A 2-Bolt Flange, SAE B Shaft (7/8" - 13T)
RE	Rotatable SAE B 4-Bolt Flange, SAE BB Shaft (1" - 15T)
RF	Rotatable SAE B 2-Bolt Flange, SAE BB Shaft (1" - 15T)
RJ	Rotatable SAE B 2 or 4-Bolt Flange, SAE BB Shaft (1" - 15T)
RK	Rotatable SAE B 2 or 4-Bolt Flange, SAE B Shaft (7/8" - 13T)
²³ RY	Rotatable ISO 7653 Pump Mount DIN 5462 Shaft
GA	Greaseable SAE B 2-Bolt Rotatable Flange, SAE B Shaft (7/8" - 13T)
GB	Greaseable SAE B 4-Bolt Rotatable Flange, SAE B Shaft (7/8" - 13T)
GF	Greaseable SAE B 2 or 4-Bolt Flange, SAE BB Shaft (1" - 15T)
GK	Greaseable SAE B 2 or 4-Bolt Flange, SAE B Shaft (7/8" - 13T)
⁵⁹ GQ	Greaseable SAE B 2 or 4-Bolt Flange, SAE B Shaft (7/8" - 13T)
GR	Greaseable Chelsea Special (Cloverleaf), SAE B Shaft (7/8" - 13T)

¹³ Available assembly 5 only

²³ Must be purchased with Wet Spline

³⁷ Automatically pressure lubed with Wet Spline

⁵⁹ Same as XK except rotated 90°

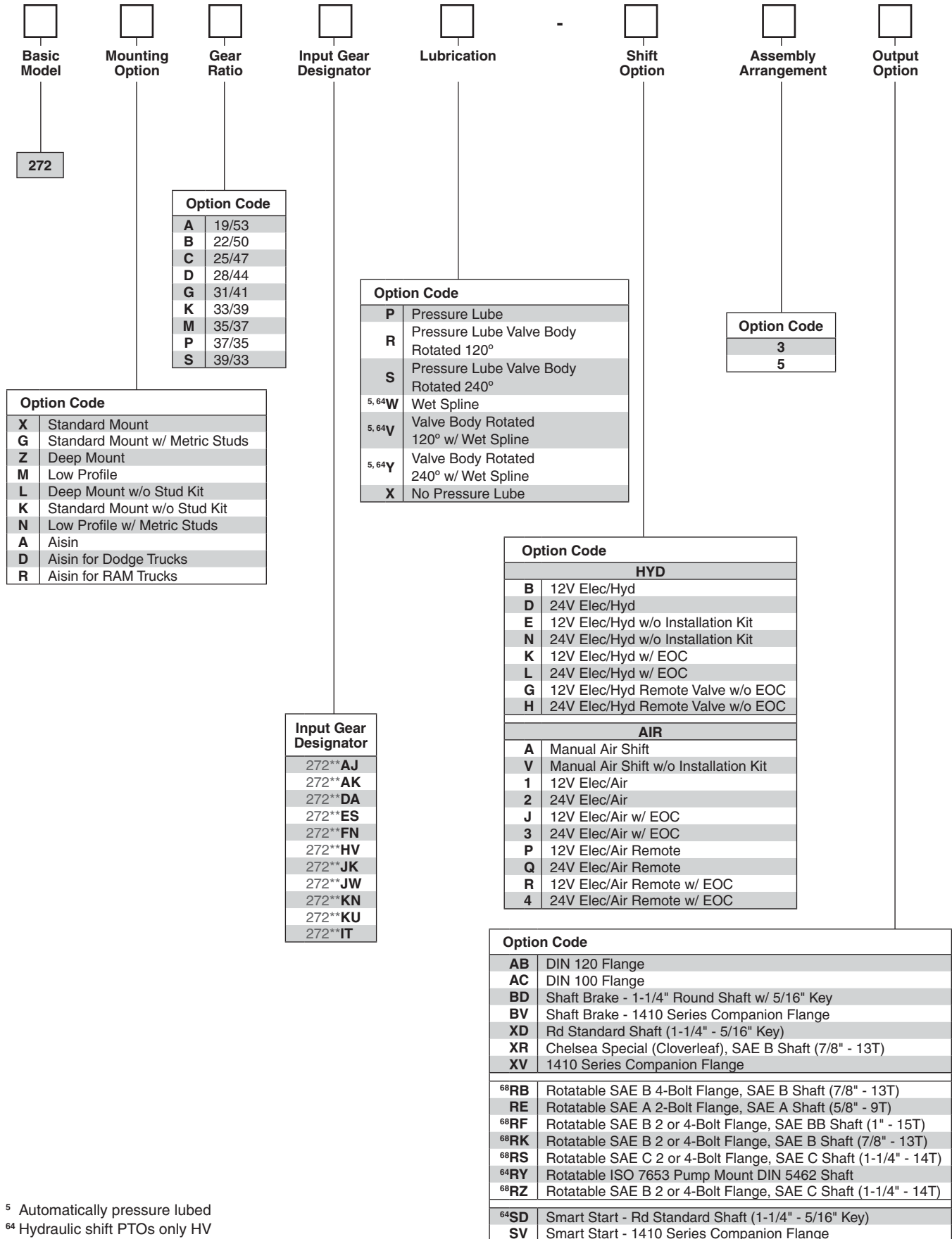

Assembly

⁵ Automatically pressure lubed
⁶⁴ Hydraulic shift PTOs only HV
⁶⁸ Check for Wet Spline availability

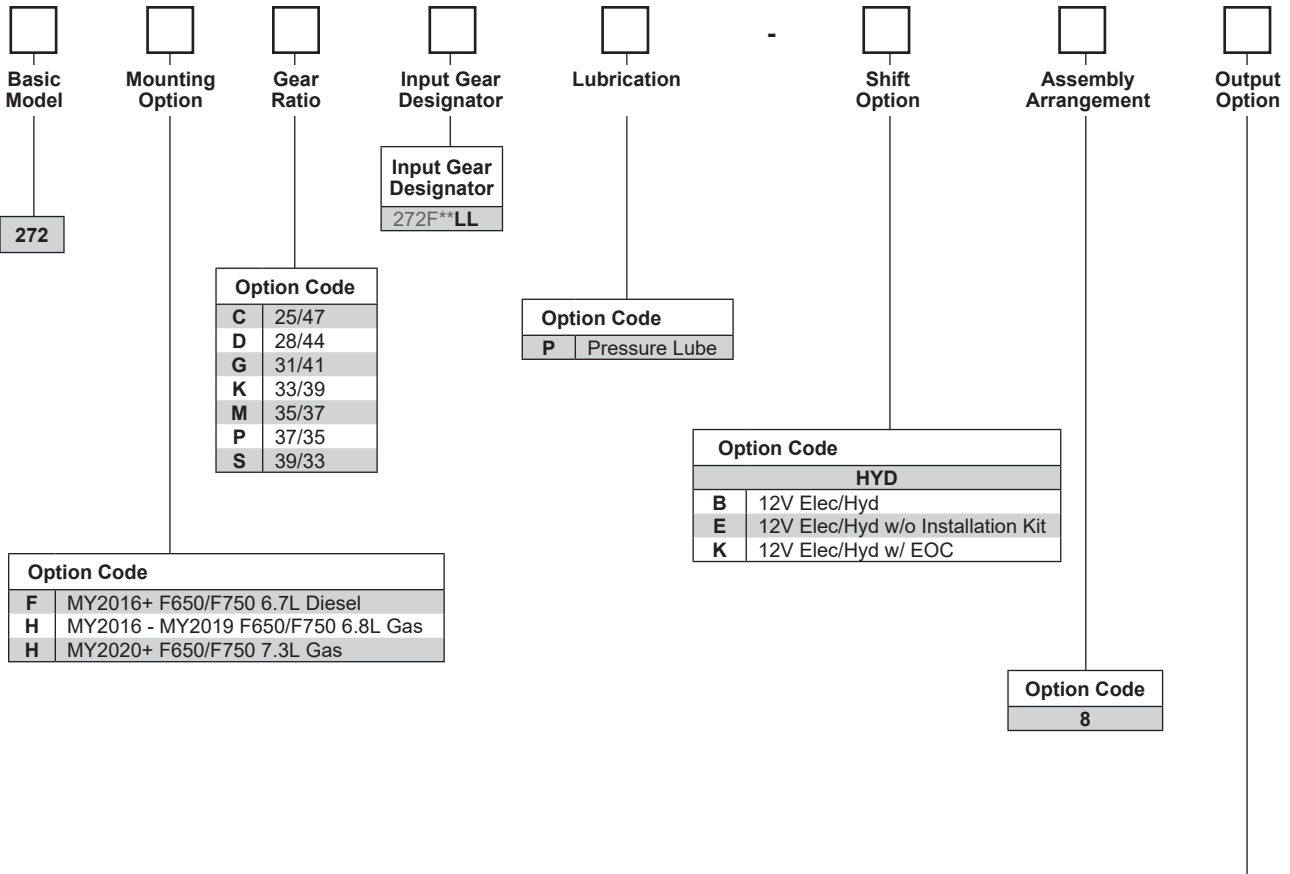

Option Code	
XD	Rd Standard Shaft (1-1/4" - 5/16" Key)
XR	Chelsea Special (Cloverleaf), SAE B Shaft (7/8" - 13T)
XV	1410 Series Companion Flange
RB	Rotatable SAE B 4-Bolt Flange, SAE B Shaft (7/8" - 13T)
RE	Rotatable SAE A 2-Bolt Flange, SAE A Shaft (5/8" - 9T)
RF	Rotatable SAE B 2 or 4-Bolt Flange, SAE BB Shaft (1" - 15T)
RK	Rotatable SAE B 2 or 4-Bolt Flange, SAE B Shaft (7/8" - 13T)
RS	Rotatable SAE C 2 or 4-Bolt Flange, SAE C Shaft (1-1/4" - 14T)
RY	Rotatable ISO 7653 Pump Mount DIN 5462 Shaft
RZ	Rotatable SAE B 2 or 4-Bolt Flange, SAE C Shaft (1-1/4" - 14T)
SD	Smart Start - Rd Standard Shaft (1-1/4" - 5/16" Key)
SV	Smart Start - 1410 Series Companion Flange

Assembly

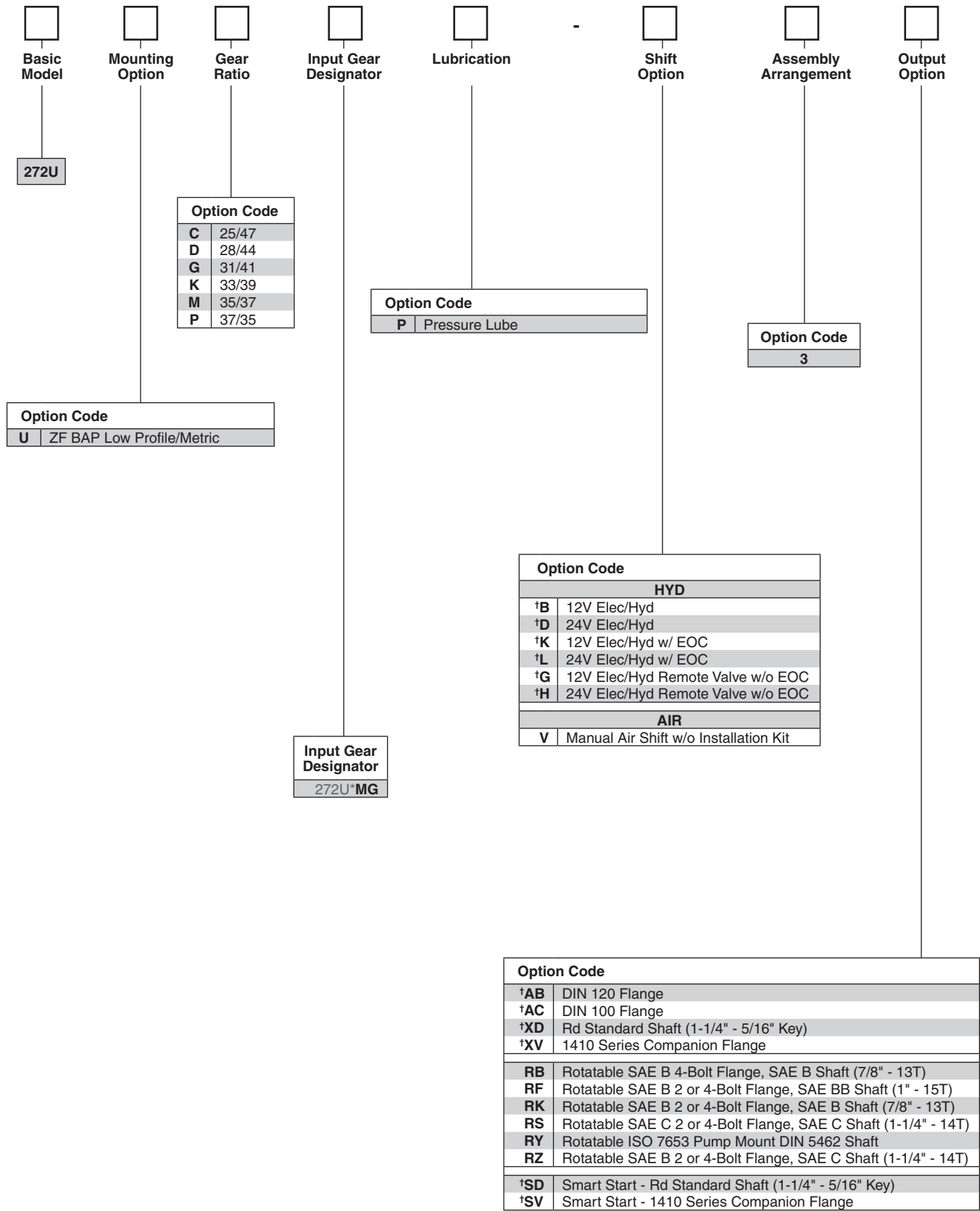

Assembly

† Coming Soon

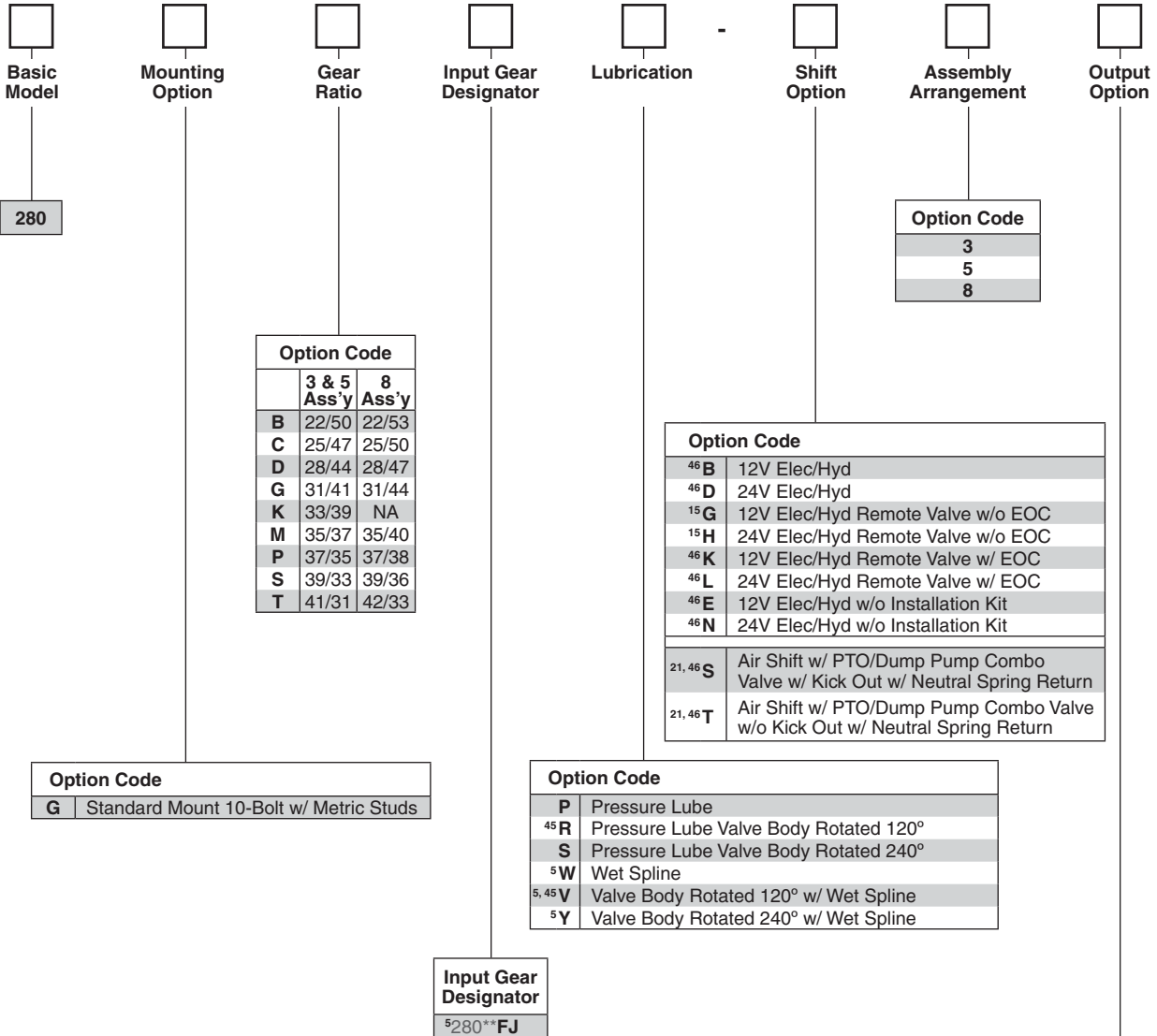

Assembly

Option Code		
	3 & 5 Ass'y	8 Ass'y
B	22/50	22/53
C	25/47	25/50
D	28/44	28/47
G	31/41	31/44
K	33/39	NA
M	35/37	35/40
P	37/35	37/38
S	39/33	39/36
T	41/31	42/33

Option Code	
⁴⁶ B	12V Elec/Hyd
⁴⁶ D	24V Elec/Hyd
¹⁵ G	12V Elec/Hyd Remote Valve w/o EOC
¹⁵ H	24V Elec/Hyd Remote Valve w/o EOC
⁴⁶ K	12V Elec/Hyd Remote Valve w/ EOC
⁴⁶ L	24V Elec/Hyd Remote Valve w/ EOC
⁴⁶ E	12V Elec/Hyd w/o Installation Kit
⁴⁶ N	24V Elec/Hyd w/o Installation Kit
^{21, 46} S	Air Shift w/ PTO/Dump Pump Combo Valve w/ Kick Out w/ Neutral Spring Return
^{21, 46} T	Air Shift w/ PTO/Dump Pump Combo Valve w/o Kick Out w/ Neutral Spring Return

Option Code	
P	Pressure Lube
⁴⁵ R	Pressure Lube Valve Body Rotated 120°
S	Pressure Lube Valve Body Rotated 240°
⁵ W	Wet Spline
^{5, 45} V	Valve Body Rotated 120° w/ Wet Spline
⁵ Y	Valve Body Rotated 240° w/ Wet Spline

Option Code	
AB	DIN 120 Flange
AC	DIN 100 Flange
BD	Shaft Brake - 1-1/4" Round w/ 5/16" Key
BV	Shaft Brake - 1410 Series Companion Flange
XD	Rd Standard Shaft (1-1/4" - 5/16" Key)
XR	Chelsea Special (Cloverleaf), SAE B Shaft (7/8" - 13T)
XV	1410 Series Companion Flange
⁶⁸ RB	Rotatable SAE B 4-Bolt Flange, SAE B Shaft (7/8" - 13T)
⁴⁷ RF	Rotatable SAE B 2 or 4-Bolt Flange, SAE BB Shaft (1" - 15T)
⁴⁷ RK	Rotatable SAE B 2 or 4-Bolt Flange, SAE B Shaft (7/8" - 13T)
⁴⁷ RS	Rotatable SAE C 2 or 4-Bolt Flange, SAE C Shaft (1-1/4" - 14T)
⁴⁷ RY	Rotatable ISO 7653 Pump Mount DIN 5462 Shaft
⁴⁷ RZ	Rotatable SAE B 2 or 4-Bolt Flange, SAE C Shaft (1-1/4" - 14T)
SB	Smart Start - DIN 120 Flange
SC	Smart Start - DIN 100 Flange
SD	Smart Start - Rd Standard Shaft (1-1/4" - 5/16" Key)
SV	Smart Start - 1410 Series Companion Flange

⁵ Automatically pressured lubed
¹⁵ The remote mount solenoid option cannot utilize the EOC option
²¹ Includes installation kit, console sold separately
⁴⁵ Available on shift option B, D, K, L, M, N, S & T
⁴⁶ Available with Rotated Valve
⁴⁷ Available with Wet Spline
⁶⁸ Check for Wet Spline availability

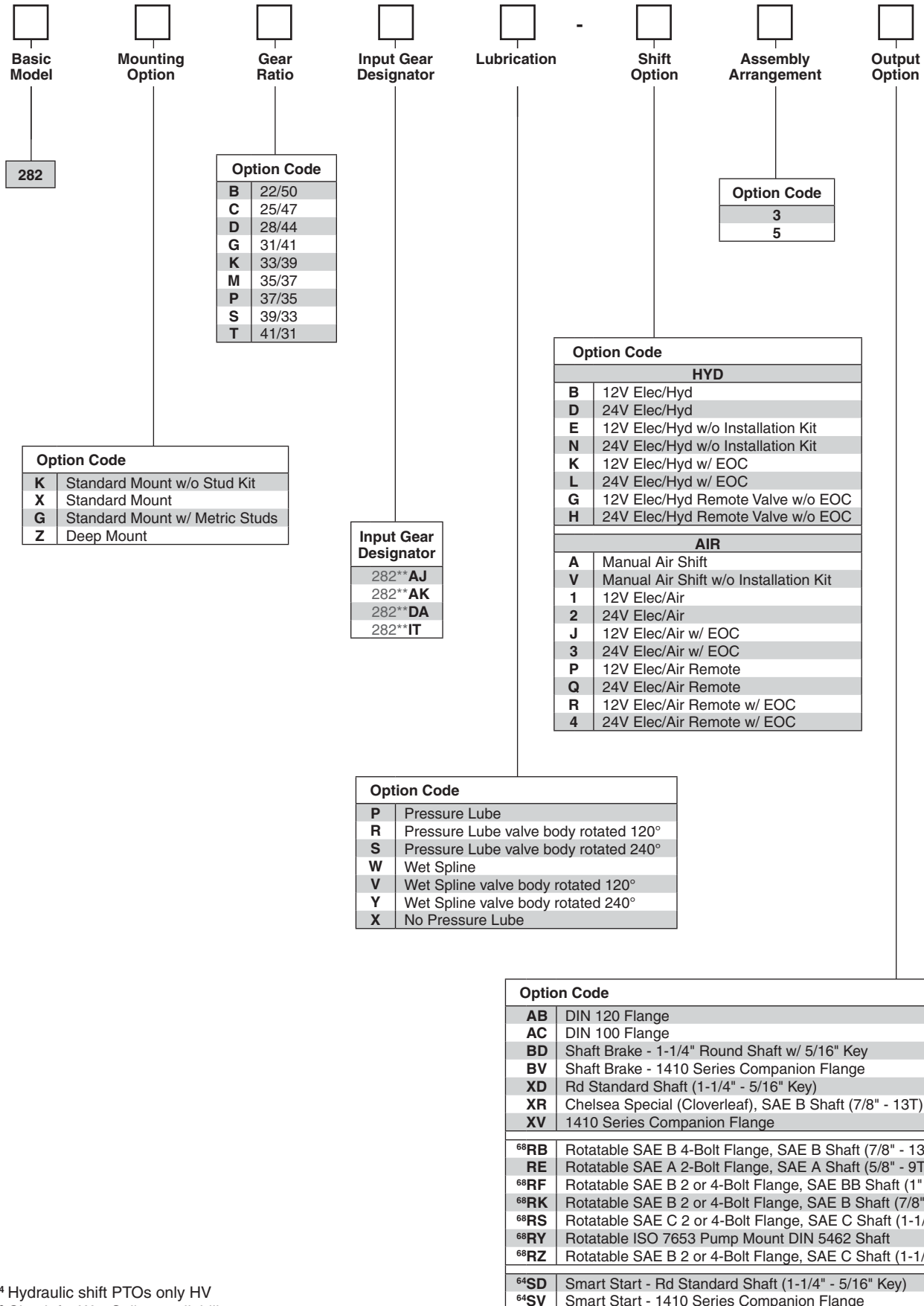

⁶⁴ Hydraulic shift PTOs only HV
⁶⁸ Check for Wet Spline availability

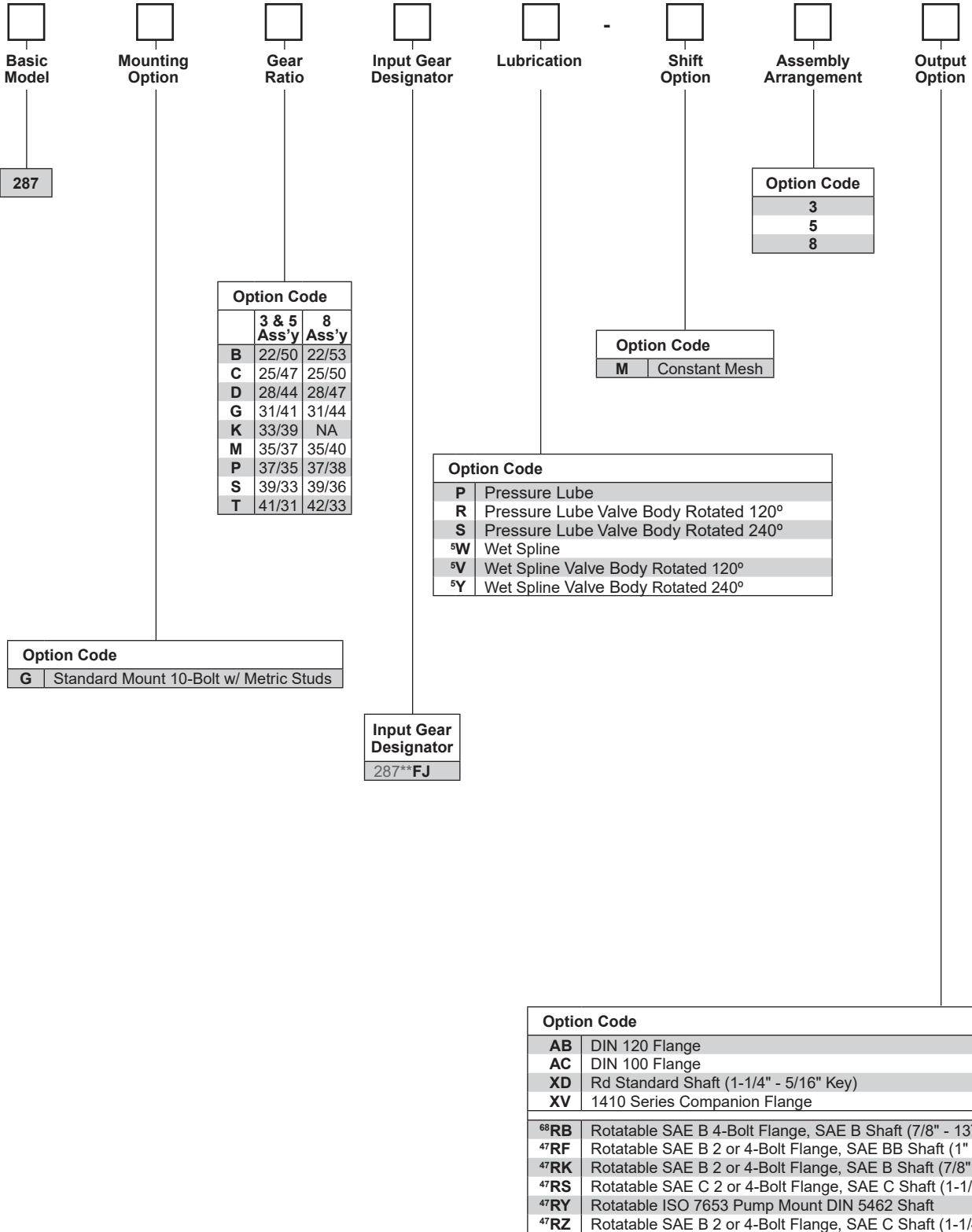

Assembly

⁵ Automatically pressured lubed
⁴⁷ Available with Wet Spline
⁶⁸ Check for Wet Spline availability

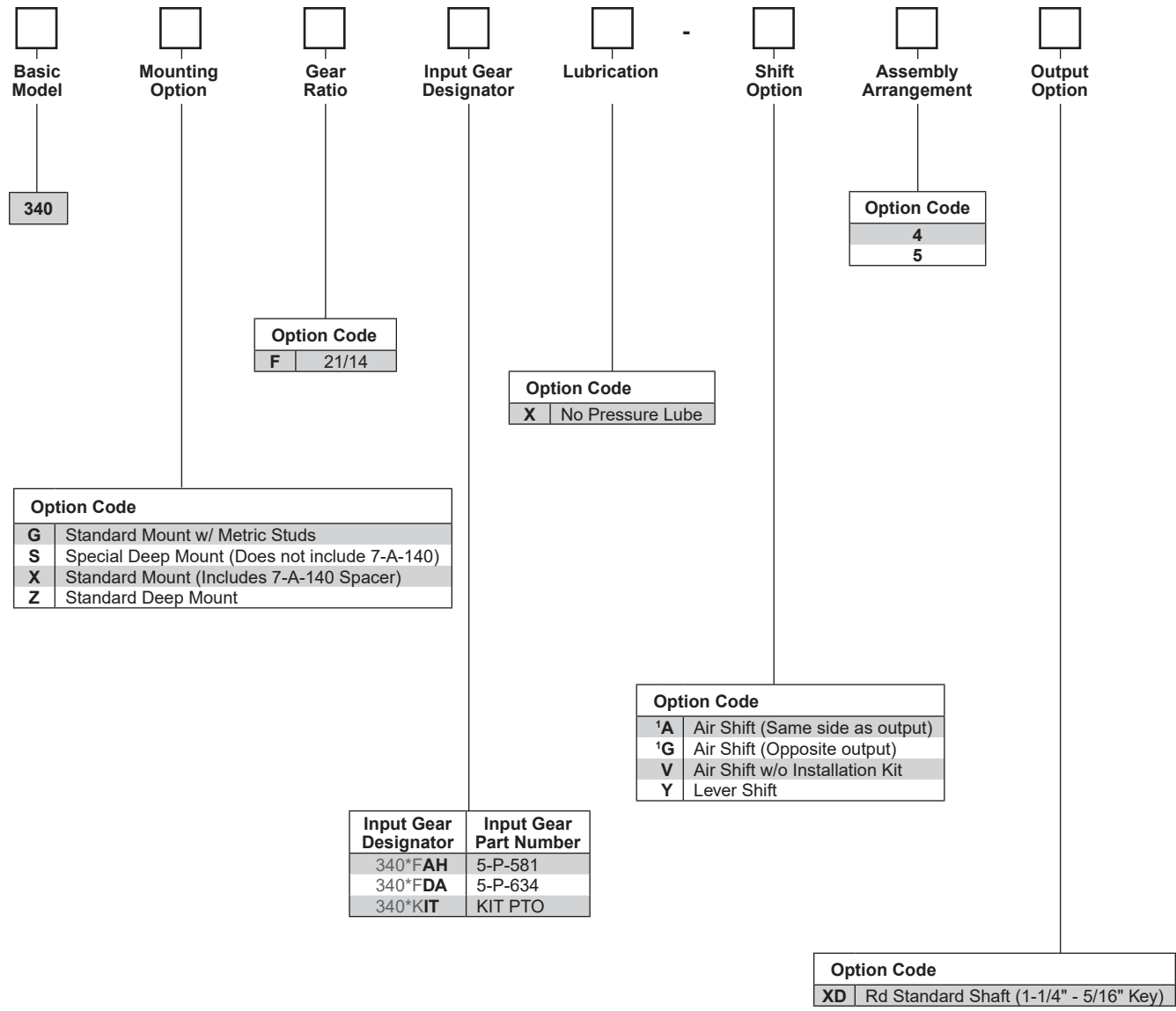

Assembly

¹ Includes mounting parts

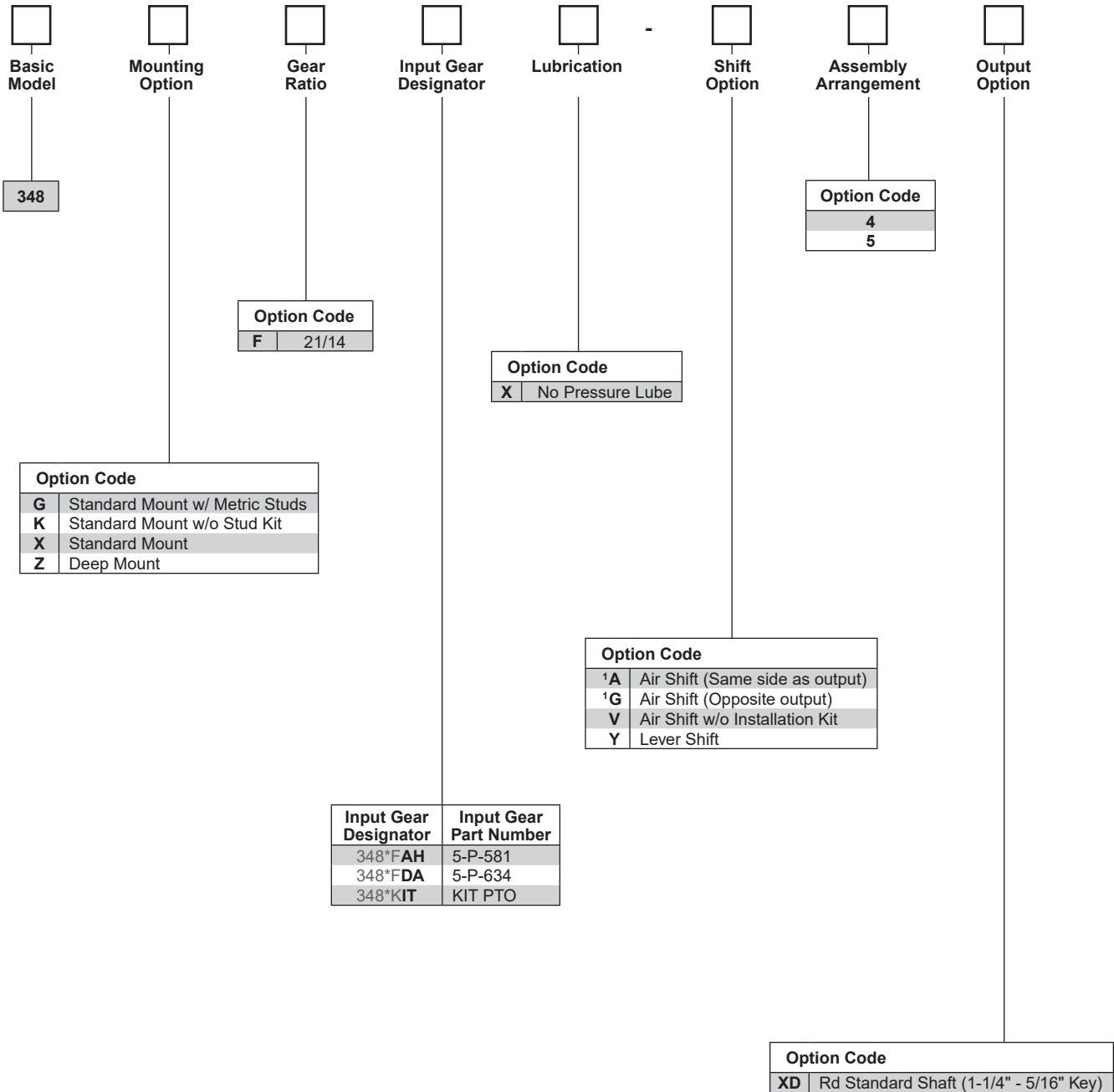

Assembly

¹ Includes mounting parts

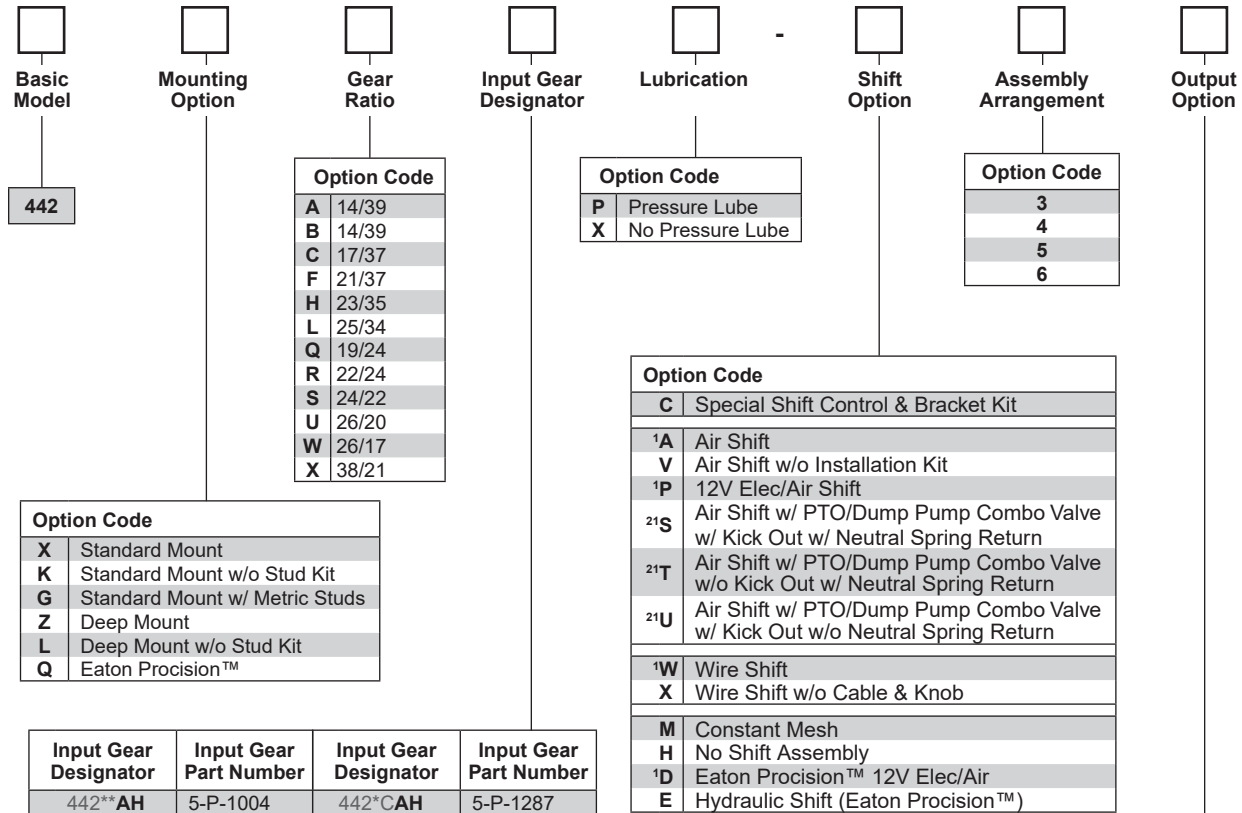

Option Code	
X	Standard Mount
K	Standard Mount w/o Stud Kit
G	Standard Mount w/ Metric Studs
Z	Deep Mount
L	Deep Mount w/o Stud Kit
Q	Eaton Procision™

Input Gear Designator	Input Gear Part Number	Input Gear Designator	Input Gear Part Number
442**AH	5-P-1004	442*CAH	5-P-1287
442**AR	5-P-1008	442*CAR	5-P-1290
442**BG	5-P-1015	442*CDA	5-P-1291
442**BQ	5-P-1023	442*FAH	5-P-1077
442**DA	5-P-1037	442*FAR	5-P-1080
442**DU	5-P-1050	442*FBG	5-P-1082
442**ES	5-P-1059	442*FBQ	5-P-1084
442**EV	5-P-1060	442*FDA	5-P-1085
442**EW	5-P-1061	442*FDU	5-P-1088
442**FN	5-P-1070	442*FES	5-P-1092
442**GR	5-P-1157	442*FEV	5-P-1094
442**GS	5-P-1152	442*FEW	5-P-1095
442**GZ	5-P-1185	442*FFN	5-P-1097
442**HH	5-P-1193	442*FGS	5-P-1151
442**HL	5-P-1196	442*FHV	5-P-1300
442**HQ	5-P-1200	442*FJU	5-P-1317
442**HY	5-P-1237	442*FJW	5-P-1320
442**JE	5-P-1249	442*HAH	5-P-1364
442**JG	5-P-1256	442*HDA	5-P-1365
442**JH	5-P-1257	442*AIT	KIT PTO
442**JK	5-P-1261	442*BIT	KIT PTO
442**JU	5-P-1316	442*CIT	KIT PTO
442**JW	5-P-1319	442*FIT	KIT PTO
442**KH	5-P-1343	442*HIT	KIT PTO
442**LP	5-P-1459	442*LIT	KIT PTO
442**LQ	5-P-1460	442*QIT	KIT PTO
442**AAH	5-P-1280	442*RIT	KIT PTO
442**AAR	5-P-1283	442*SIT	KIT PTO
442**ADA	5-P-1284	442*UIT	KIT PTO
442**AES	5-P-1285	442*WIT	KIT PTO
⁷⁶ 442**BAH	5-P-1418	442*XIT	KIT PTO
⁷⁶ 442**BHV	5-P-1358		

Option Code	
C	Special Shift Control & Bracket Kit
¹ A	Air Shift
V	Air Shift w/o Installation Kit
¹ P	12V Elec/Air Shift
²¹ S	Air Shift w/ PTO/Dump Pump Combo Valve w/ Kick Out w/ Neutral Spring Return
²¹ T	Air Shift w/ PTO/Dump Pump Combo Valve w/o Kick Out w/ Neutral Spring Return
²¹ U	Air Shift w/ PTO/Dump Pump Combo Valve w/ Kick Out w/o Neutral Spring Return
¹ W	Wire Shift
X	Wire Shift w/o Cable & Knob
M	Constant Mesh
H	No Shift Assembly
¹ D	Eaton Procision™ 12V Elec/Air
E	Hydraulic Shift (Eaton Procision™)

Option Code	
AF	SAE B 2 or 4-Bolt Flange, SAE BB Shaft (1" - 15T)
AK	SAE B 2-Bolt Flange, SAE B Shaft (7/8" - 13T)
AZ	SAE B 4-Bolt Flange, SAE C Shaft (1-1/4" - 14T)
SQ	SAE B 4-Bolt Flange, SAE B Shaft (7/8" - 13T)
XD	Rd Standard Shaft (1-1/4" - 5/16" Key)
XE	SAE A 2 or 4-Bolt Flange, SAE A Shaft (5/8" - 9T)
XK	SAE B 2 or 4-Bolt Flange, SAE B Shaft (7/8" - 13T)
⁵⁹ XQ	SAE B 2 or 4-Bolt Flange, SAE B Shaft (7/8" - 13T)
XR	Chelsea Special (Cloverleaf), SAE B Shaft (7/8" - 13T)
XX	1-1/4" Tapered Output Shaft w/ Keyway
XY	ISO 7653 Pump Mount DIN 5462 Shaft
RA	Rotatable SAE B 2-Bolt Flange, SAE B Shaft (7/8" - 13T)
RB	Rotatable SAE B 4-Bolt Flange, SAE B Shaft (7/8" - 13T)
RC	Rotatable SAE A 2-Bolt Flange, SAE A Shaft (5/8" - 9T)
RD	Rotatable SAE A 2-Bolt Flange, SAE B Shaft (7/8" - 13T)
RE	Rotatable SAE B 4-Bolt Flange, SAE BB Shaft (1" - 15T)
RF	Rotatable SAE B 2-Bolt Flange, SAE BB Shaft (1" - 15T)
RK	Rotatable SAE B 2 or 4-Bolt Flange, SAE B Shaft (7/8" - 13T)
⁷⁹ RY	Rotatable ISO 7653 Pump Mount DIN 5462 Shaft
GA	Greaseable SAE B 2-Bolt Rotatable Flange, SAE B Shaft (7/8" - 13T)
GB	Greaseable SAE B 4-Bolt Rotatable Flange, SAE B Shaft (7/8" - 13T)
GF	Greaseable SAE B 2 or 4-Bolt Flange, SAE BB Shaft (1" - 15T)
GK	Greaseable SAE B 2 or 4-Bolt Flange, SAE B Shaft (7/8" - 13T)
⁵⁹ GQ	Greaseable SAE B 2 or 4-Bolt Flange, SAE B Shaft (7/8" - 13T)
GR	Greaseable Chelsea Special (Cloverleaf), SAE B Shaft (7/8" - 13T)

Assembly

¹ Includes mounting parts
²¹ Includes installation kit, console sold separately
⁵⁹ Same as XK except rotated 90°
⁷⁶ B ratio NOT available with AF, AZ, GA, GB, GF, GK, GQ, GR, RC, RE, RF, XE or XX output options
⁷⁹ Flooded cavity

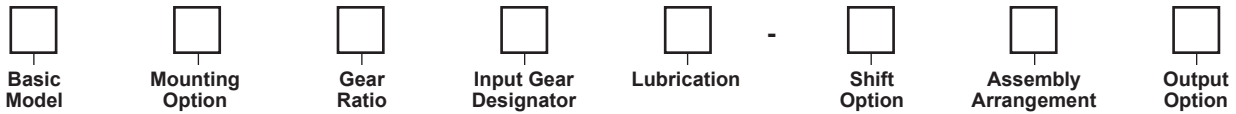

447

Option Code	
Q	19/24
S	24/22
U	26/20
W	26/17

Option Code	
P	Pressure Lube
X	No Pressure Lube

Option Code	
3	
4	
5	
6	

Option Code	
G	Standard Mount w/ Metric Studs
K	Standard Mount w/o Stud Kit
L	Deep Mount w/o Stud Kit
X	Standard Mount
Z	Deep Mount

Input Gear Designator	Input Gear Part Number
447*QET	5-P-865
447*SES	5-P-870
447*SET	5-P-866
447*UES	5-P-871
447*UET	5-P-867
447*WES	5-P-872
447*QIT	KIT PTO
447*SIT	KIT PTO
447*UIT	KIT PTO
447*WIT	KIT PTO

Option Code	
C	Special Shift Control & Bracket Kit
1A	Air Shift
V	Air Shift w/o Installation Kit
1P	12V Elec/Air Shift
21S	Air Shift w/ PTO/Dump Pump Combo Valve w/ Kick Out w/ Neutral Spring Return
21T	Air Shift w/ PTO/Dump Pump Combo Valve w/o Kick Out w/ Neutral Spring Return
21U	Air Shift w/ PTO/Dump Pump Combo Valve w/ Kick Out w/o Neutral Spring Return
1W	Wire Shift
X	Wire Shift w/o Cable & Knob
H	No Shift Assembly
M	Constant Mesh

Option Code	
AF	SAE B 2 or 4-Bolt Flange, SAE BB Shaft (1" - 15T)
AK	SAE B 2-Bolt Flange, SAE B Shaft (7/8" - 13T)
AZ	SAE B 4-Bolt Flange, SAE C Shaft (1-1/4" - 14T)
XD	Rd Standard Shaft (1-1/4" - 5/16" Key)
XE	SAE A 2 or 4-Bolt Flange, SAE A Shaft (5/8" - 9T)
XK	SAE B 2 or 4-Bolt Flange, SAE B Shaft (7/8" - 13T)
59XQ	SAE B 2 or 4-Bolt Flange, SAE B Shaft (7/8" - 13T)
XR	Chelsea Special (Cloverleaf), SAE B Shaft (7/8" - 13T)
XX	1-1/4" Tapered Output Shaft w/ Keyway
XY	ISO 7653 Pump Mount DIN 5462 Shaft
RA	Rotatable SAE B 2-Bolt Flange, SAE B Shaft (7/8" - 13T)
RB	Rotatable SAE B 4-Bolt Flange, SAE B Shaft (7/8" - 13T)
RC	Rotatable SAE A 2-Bolt Flange, SAE A Shaft (5/8" - 9T)
RD	Rotatable SAE A 2-Bolt Flange, SAE B Shaft (7/8" - 13T)
RE	Rotatable SAE B 4-Bolt Flange, SAE BB Shaft (1" - 15T)
RF	Rotatable SAE B 2-Bolt Flange, SAE BB Shaft (1" - 15T)
RK	Rotatable SAE B 2 or 4-Bolt Flange, SAE B Shaft (7/8" - 13T)
79RY	Rotatable ISO 7653 Pump Mount DIN 5462 Shaft
GA	Greaseable SAE B 2-Bolt Rotatable Flange, SAE B Shaft (7/8" - 13T)
GB	Greaseable SAE B 4-Bolt Rotatable Flange, SAE B Shaft (7/8" - 13T)
GF	Greaseable SAE B 2 or 4-Bolt Flange, SAE BB Shaft (1" - 15T)
GK	Greaseable SAE B 2 or 4-Bolt Flange, SAE B Shaft (7/8" - 13T)
59GQ	Greaseable SAE B 2 or 4-Bolt Flange, SAE B Shaft (7/8" - 13T)
GR	Greaseable Chelsea Special (Cloverleaf), SAE B Shaft (7/8" - 13T)

Assembly

¹ Includes mounting parts
²¹ Includes installation kit, console sold separately
⁵⁹ Same as XK except rotated 90°
⁷⁹ Flooded cavity

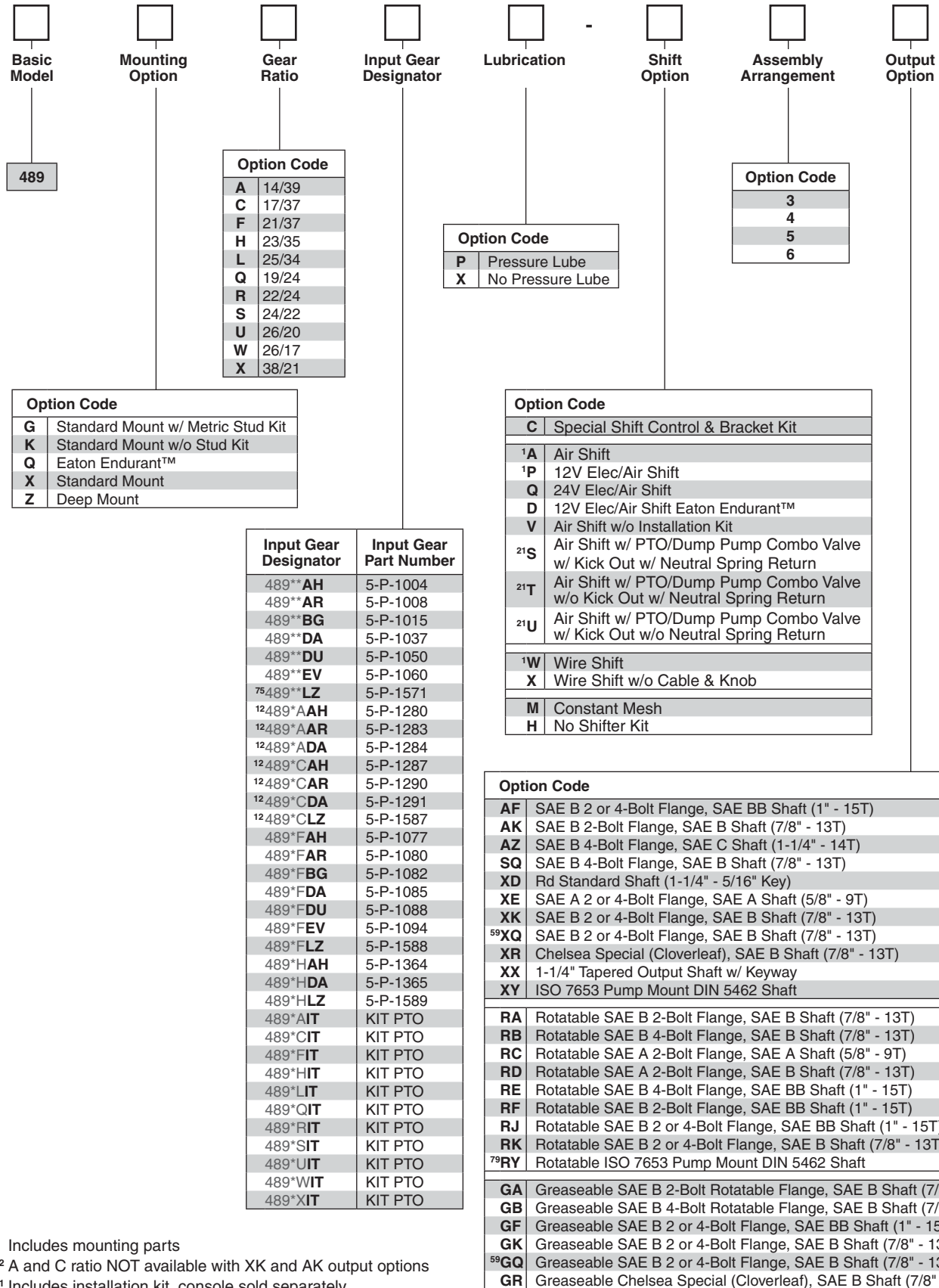

Assembly

¹ Includes mounting parts

¹² A and C ratio NOT available with XK and AK output options

²¹ Includes installation kit, console sold separately

⁵⁹ Same as XK except rotated 90°

⁷⁵ Must use D or V shift options only

⁷⁹ Flooded cavity

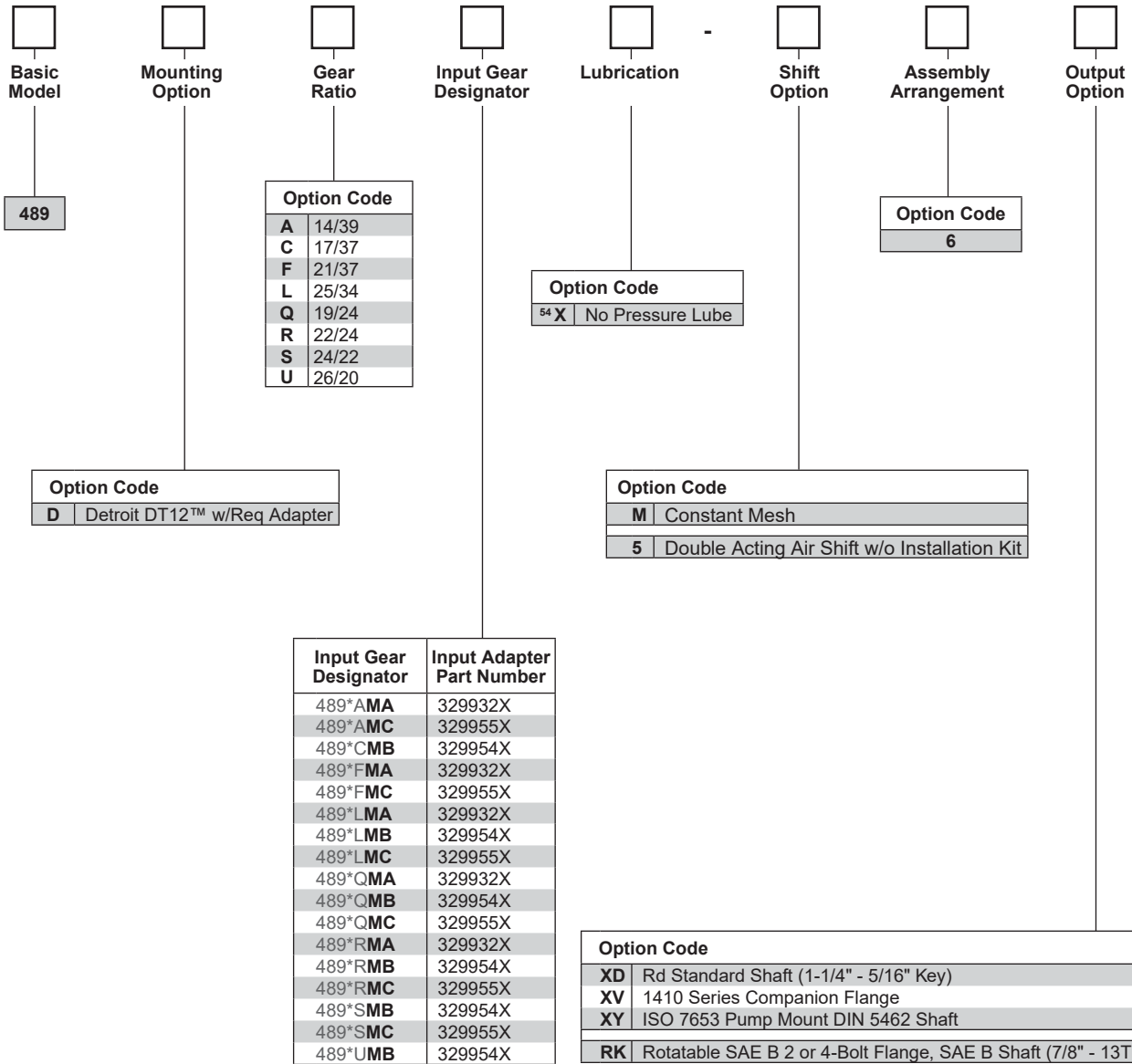

Assembly

¹ Includes mounting parts

⁵⁴ X Lube option only

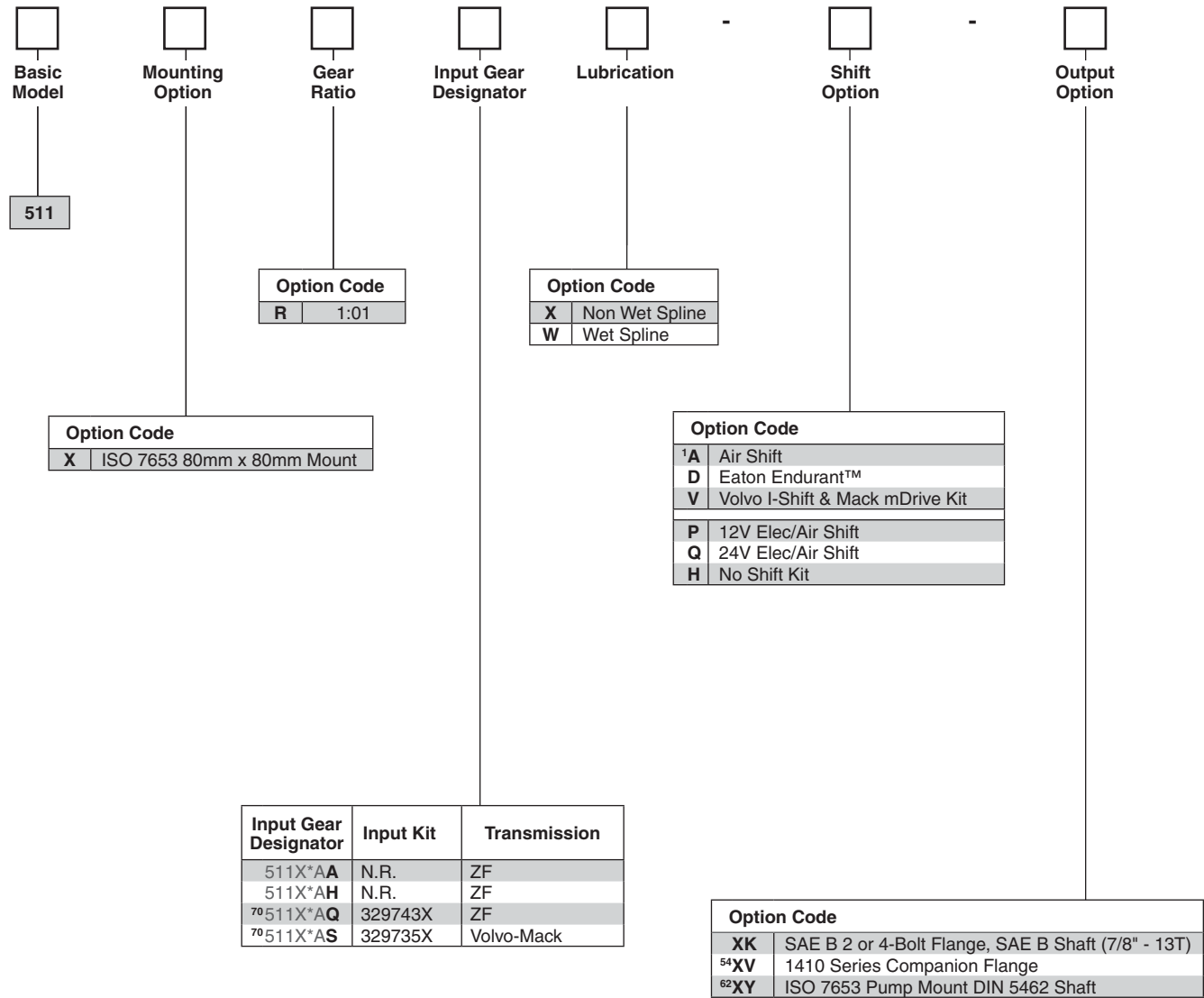

Assembly

¹ Includes mounting parts

⁵⁴ X Lube option only

⁶² Wet Spline only

⁷⁰ Input kits are included with PTO assembly

N.R. = Not Required

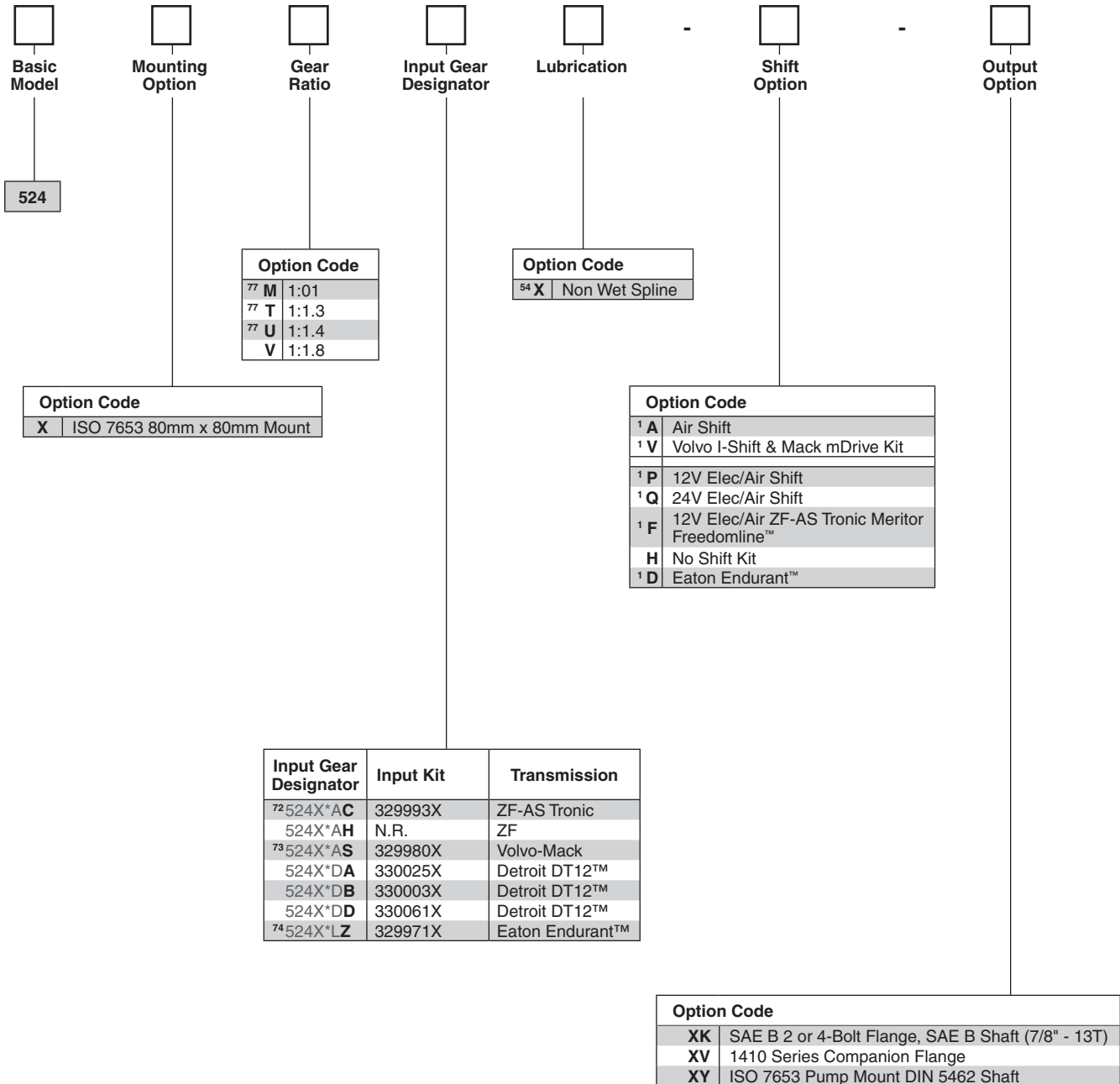

Assembly

¹ Includes mounting parts

⁵⁴ X Lube option only

⁷² AC Input Gear can use H or F Shift Options Only

⁷³ AS Input Gear can use H or V Shift Options Only

⁷⁴ LZ Input Gear can use H or D Shift Options Only

⁷⁷ Ships with sculpted housing for DT12 applications (DA and DB Input Kits)

N.R. = Not Required

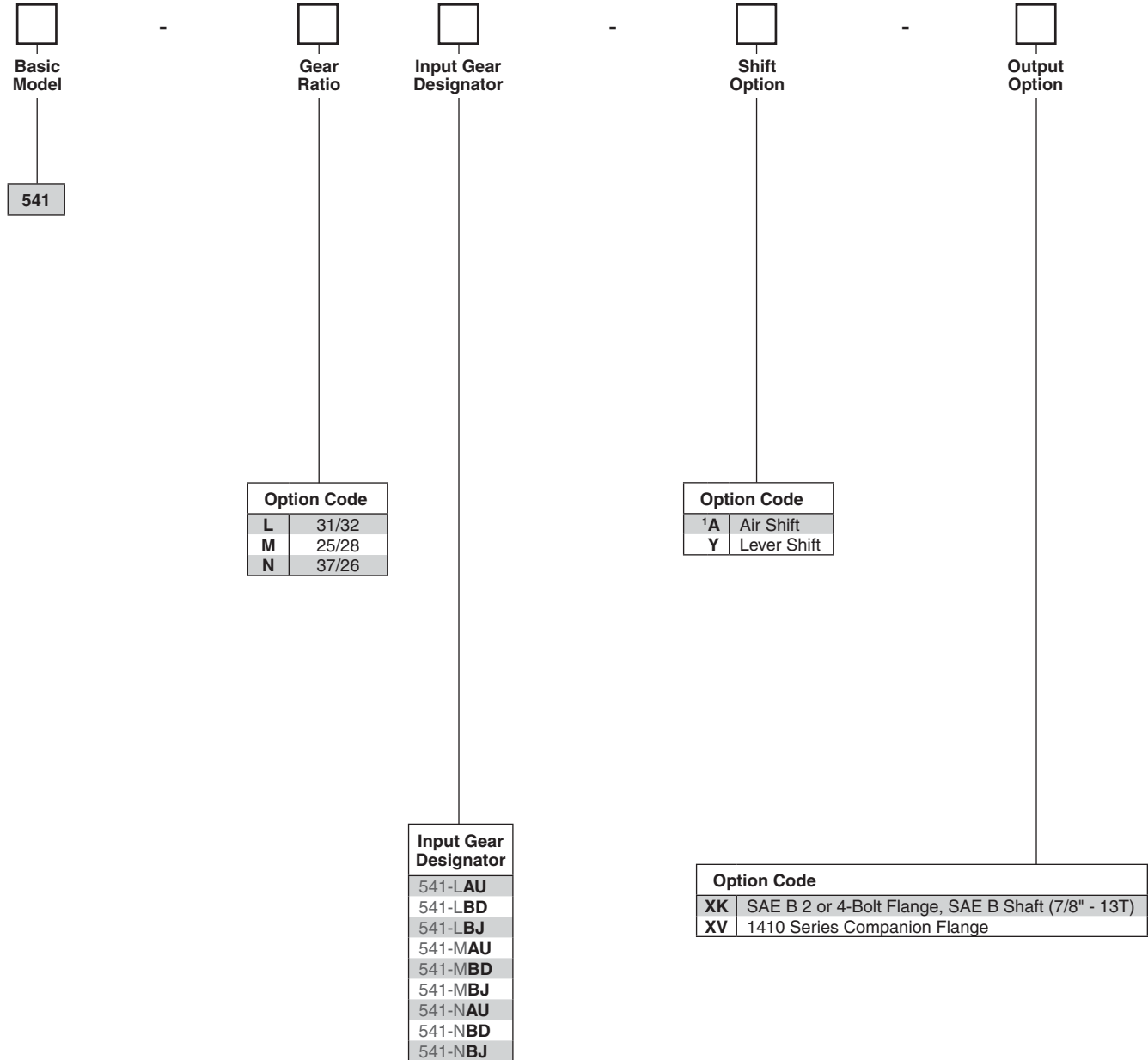

Assembly

¹ Includes mounting parts

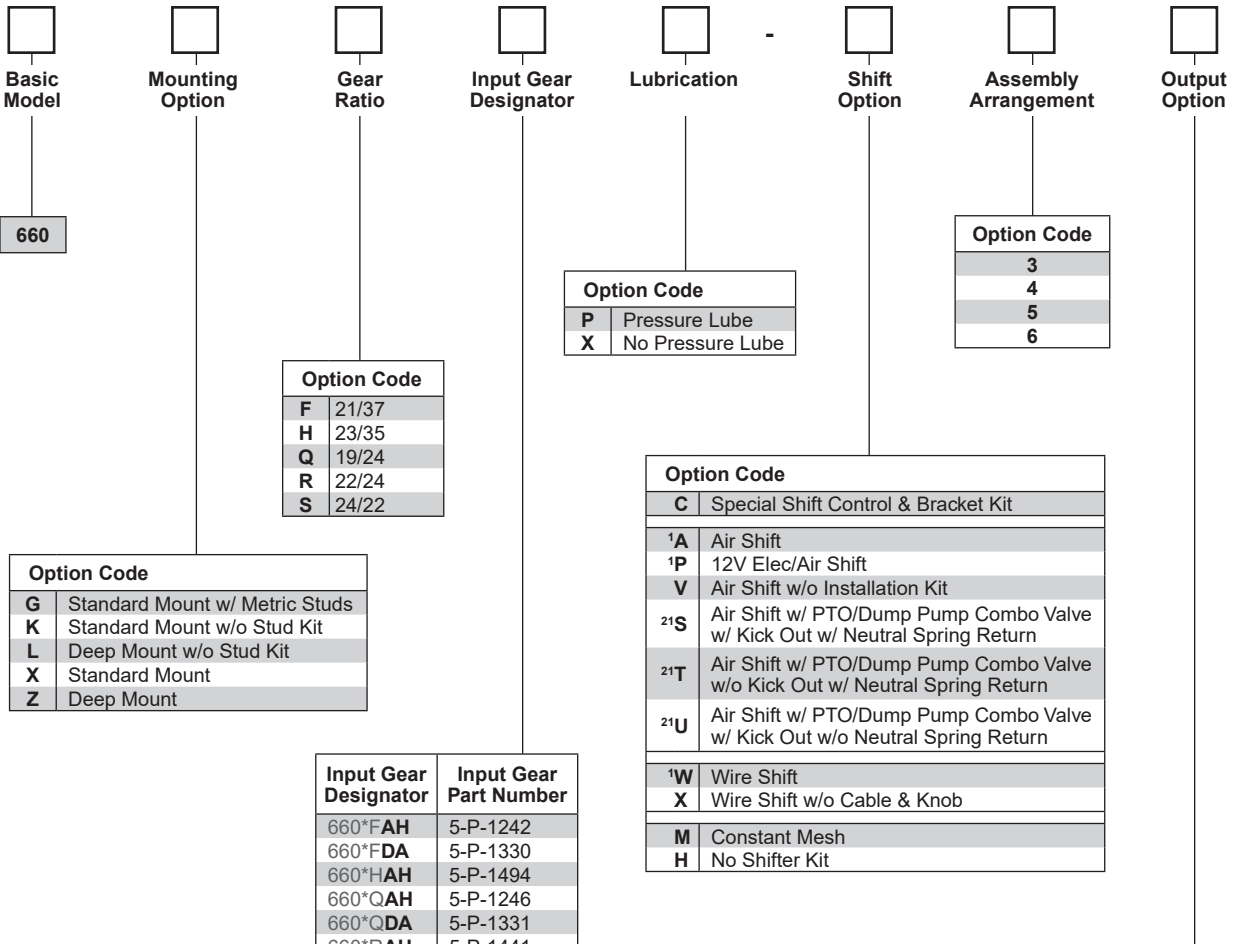

660

Option Code	
F	21/37
H	23/35
Q	19/24
R	22/24
S	24/22

Option Code	
G	Standard Mount w/ Metric Studs
K	Standard Mount w/o Stud Kit
L	Deep Mount w/o Stud Kit
X	Standard Mount
Z	Deep Mount

Input Gear Designator	Input Gear Part Number
660*FAH	5-P-1242
660*FDA	5-P-1330
660*HAH	5-P-1494
660*QAH	5-P-1246
660*QDA	5-P-1331
660*RAH	5-P-1441
660*SAH	5-P-1322
660*SDA	5-P-1332

Option Code	
P	Pressure Lube
X	No Pressure Lube

Option Code	
3	
4	
5	
6	

Option Code	
C	Special Shift Control & Bracket Kit
¹ A	Air Shift
¹ P	12V Elec/Air Shift
V	Air Shift w/o Installation Kit
²¹ S	Air Shift w/ PTO/Dump Pump Combo Valve w/ Kick Out w/ Neutral Spring Return
²¹ T	Air Shift w/ PTO/Dump Pump Combo Valve w/o Kick Out w/ Neutral Spring Return
²¹ U	Air Shift w/ PTO/Dump Pump Combo Valve w/ Kick Out w/o Neutral Spring Return
¹ W	Wire Shift
X	Wire Shift w/o Cable & Knob
M	Constant Mesh
H	No Shifter Kit

Option Code	
AF	SAE B 2 or 4-Bolt Flange, SAE BB Shaft (1" - 15T)
AK	SAE B 2-Bolt Flange, SAE B Shaft (7/8" - 13T)
AZ	SAE B 4-Bolt Flange, SAE C Shaft (1-1/4" - 14T)
XD	Rd Standard Shaft (1-1/4" - 5/16" Key)
XE	SAE A 2 or 4-Bolt Flange, SAE A Shaft (5/8" - 9T)
XK	SAE B 2 or 4-Bolt Flange, SAE B Shaft (7/8" - 13T)
⁵⁹ XQ	SAE B 2 or 4-Bolt Flange, SAE B Shaft (7/8" - 13T)
XR	Chelsea Special (Cloverleaf), SAE B Shaft (7/8" - 13T)
XV	1410 Series Companion Flange
XX	1-1/4" Tapered Output Shaft w/ Keyway
XY	ISO 7653 Pump Mount DIN 5462 Shaft
RA	Rotatable SAE B 2-Bolt Flange, SAE B Shaft (7/8" - 13T)
RB	Rotatable SAE B 4-Bolt Flange, SAE B Shaft (7/8" - 13T)
RC	Rotatable SAE A 2-Bolt Flange, SAE A Shaft (5/8" - 9T)
RD	Rotatable SAE A 2-Bolt Flange, SAE B Shaft (7/8" - 13T)
RE	Rotatable SAE B 4-Bolt Flange, SAE BB Shaft (1" - 15T)
RF	Rotatable SAE B 2-Bolt Flange, SAE BB Shaft (1" - 15T)
RJ	Rotatable SAE B 2 or 4-Bolt Flange, SAE BB Shaft (1" - 15T)
RK	Rotatable SAE B 2 or 4-Bolt Flange, SAE B Shaft (7/8" - 13T)
⁷⁹ RY	Rotatable ISO 7653 Pump Mount DIN 5462 Shaft
GA	Greaseable SAE B 2-Bolt Rotatable Flange, SAE B Shaft (7/8" - 13T)
GB	Greaseable SAE B 4-Bolt Rotatable Flange, SAE B Shaft (7/8" - 13T)
GF	Greaseable SAE B 2 or 4-Bolt Flange, SAE BB Shaft (1" - 15T)
GH	Greaseable SAE B 2-Bolt Rotatable Flange, SAE BB Shaft (1" - 15T)
GK	Greaseable SAE B 2 or 4-Bolt Flange, SAE B Shaft (7/8" - 13T)
⁵⁹ GQ	Greaseable SAE B 2 or 4-Bolt Flange, SAE B Shaft (7/8" - 13T)
GR	Greaseable Chelsea Special (Cloverleaf), SAE B Shaft (7/8" - 13T)
GY	Greaseable ISO 7653 Pump Mount DIN 5462 Shaft
GZ	Greaseable SAE B 2 or 4-Bolt Flange, SAE C Shaft (1-1/4" - 14T)

¹ Includes mounting parts
²¹ Includes installation kit, console sold separately
⁵⁹ Same as XK except rotated 90°
⁷⁹ Flooded cavity

Assembly

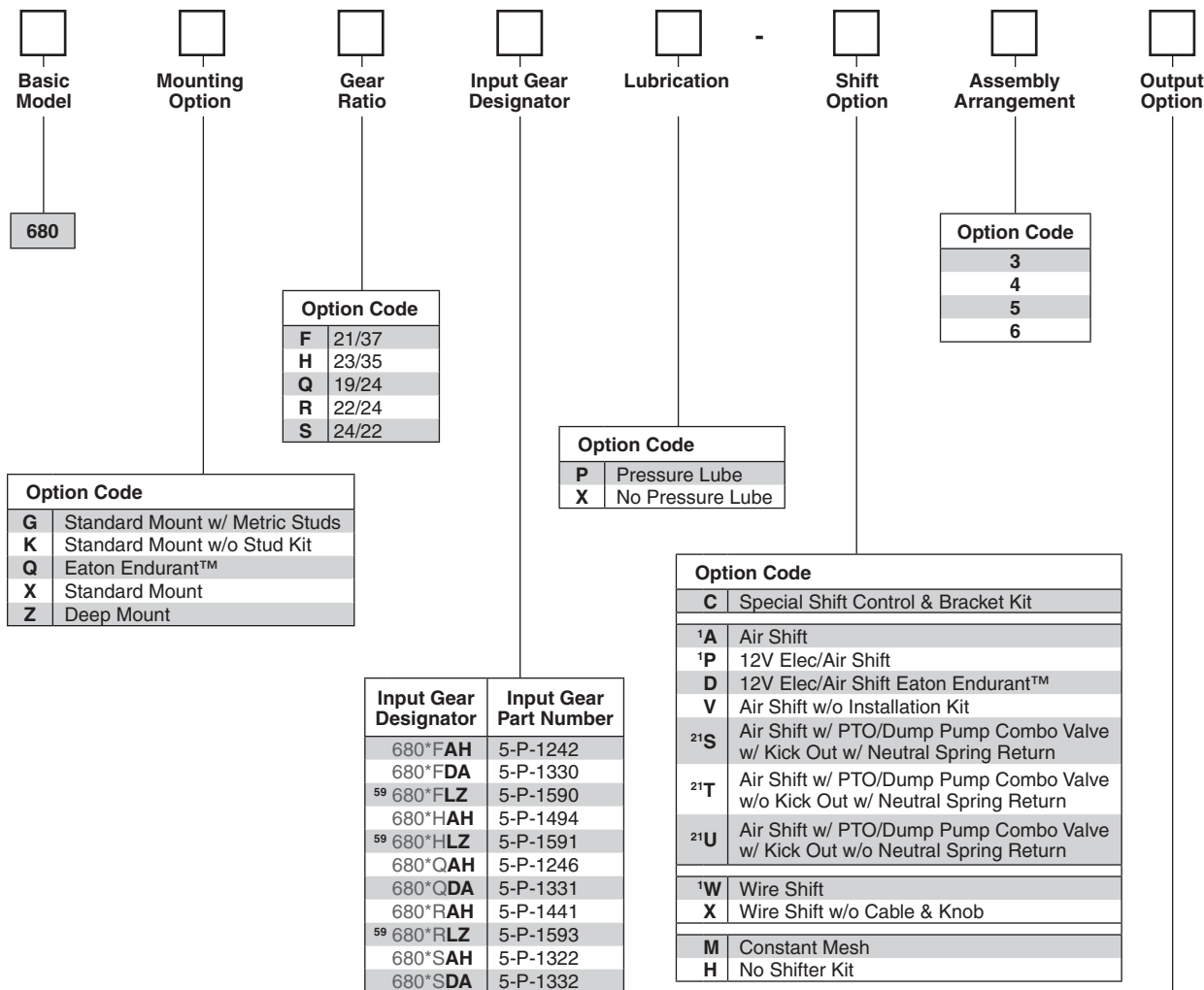

¹ Includes mounting parts

²¹ Includes installation kit, console sold separately

⁵⁹ Same as XK except rotated 90°

⁷⁵ Must use D or V shift options only

⁷⁹ Flooded cavity

Assembly

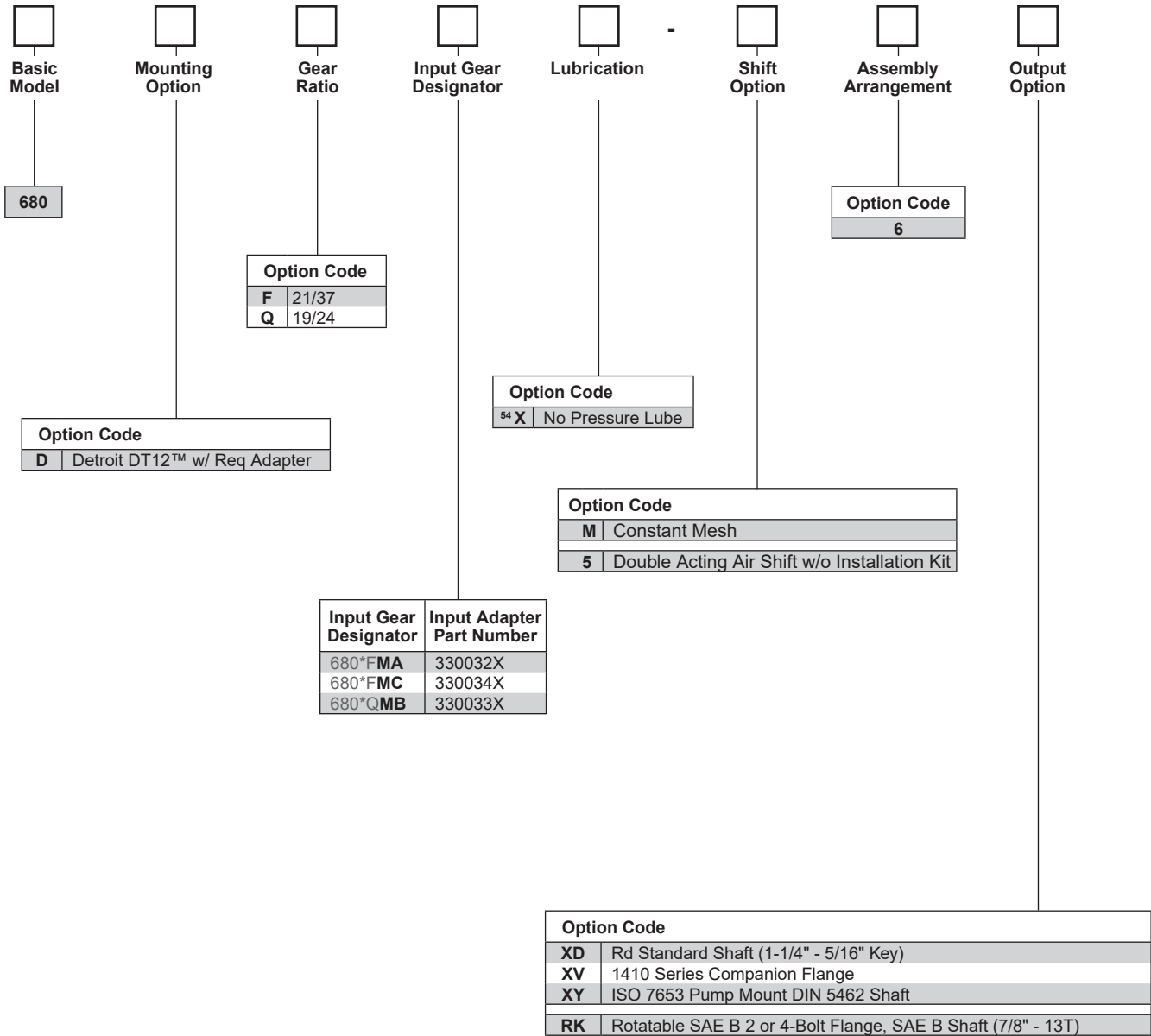

Assembly

¹ Includes mounting parts

⁵⁴ X Lube option only

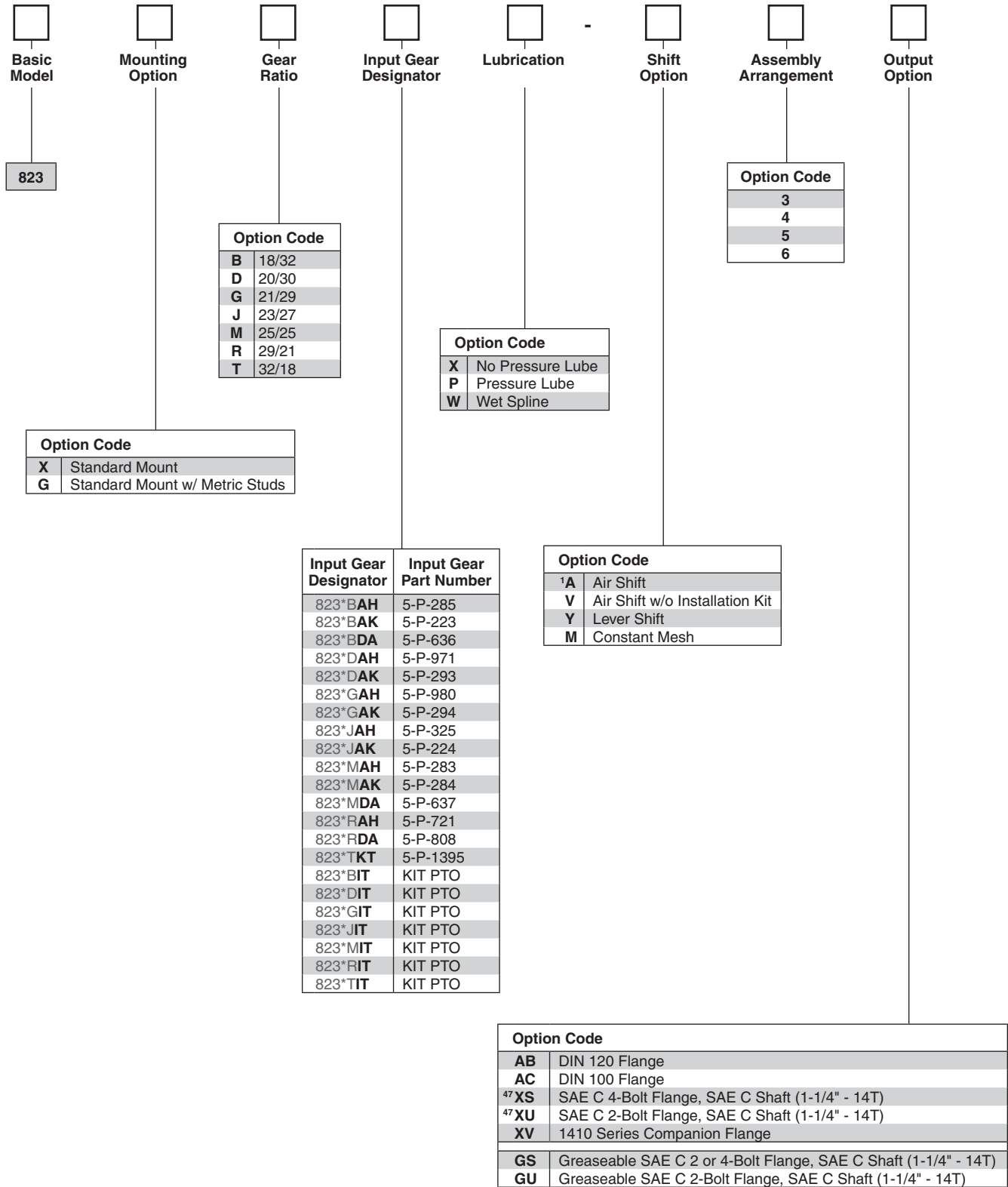

Assembly

¹ Includes mounting parts

⁴⁷ Available with Wet Spline

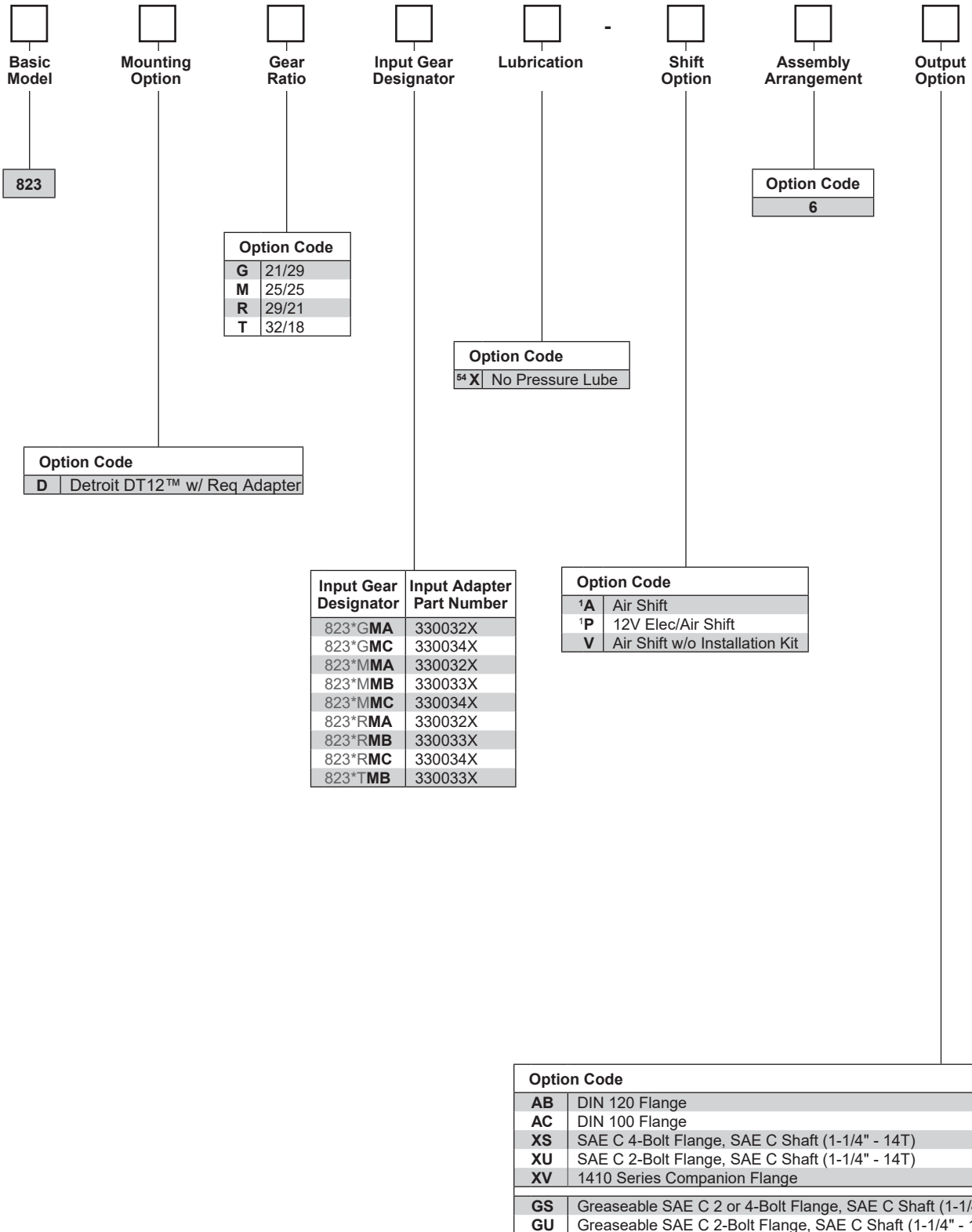

Assembly

¹ Includes mounting parts

⁵⁴ X Lube option only

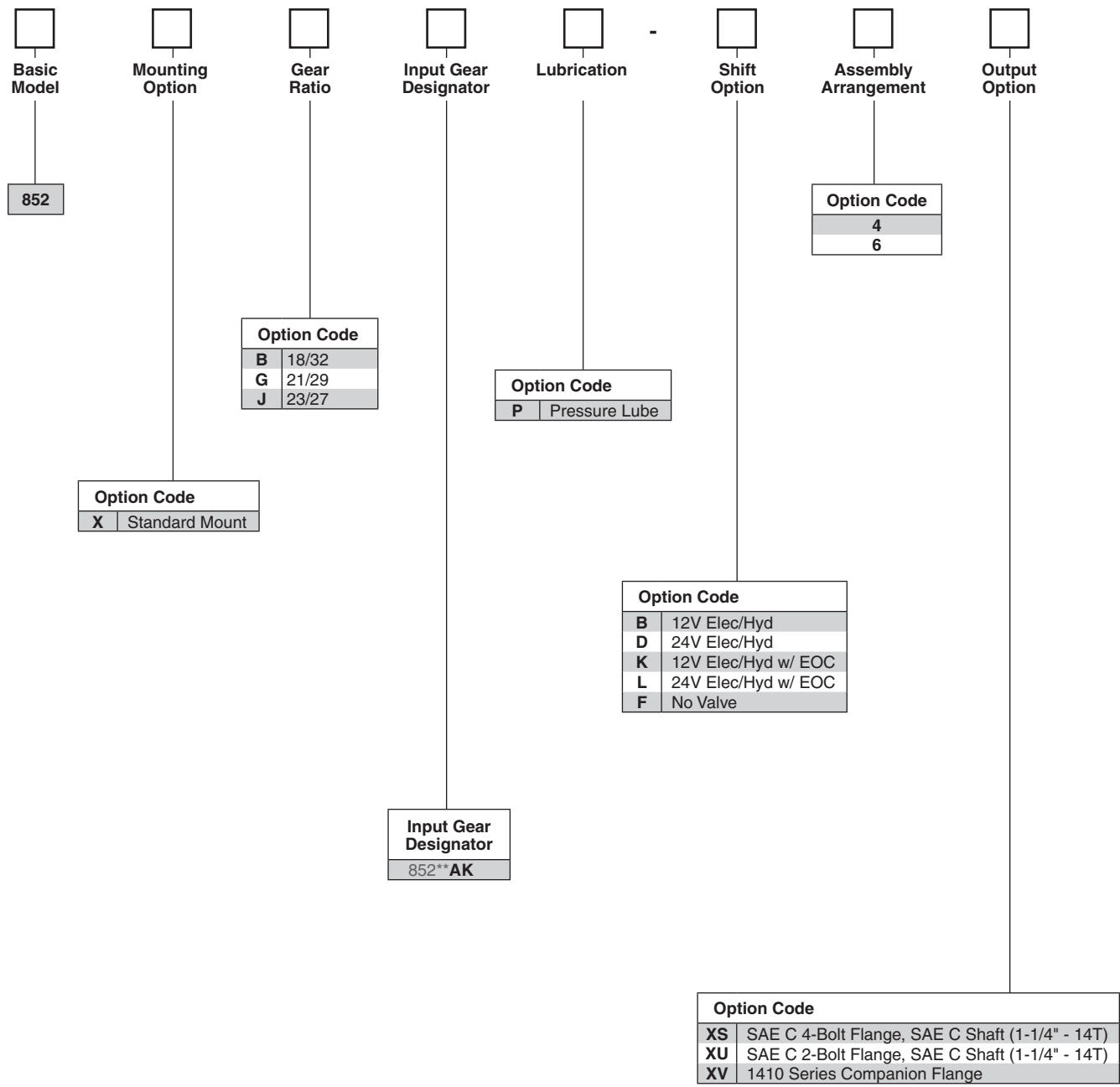

Assembly

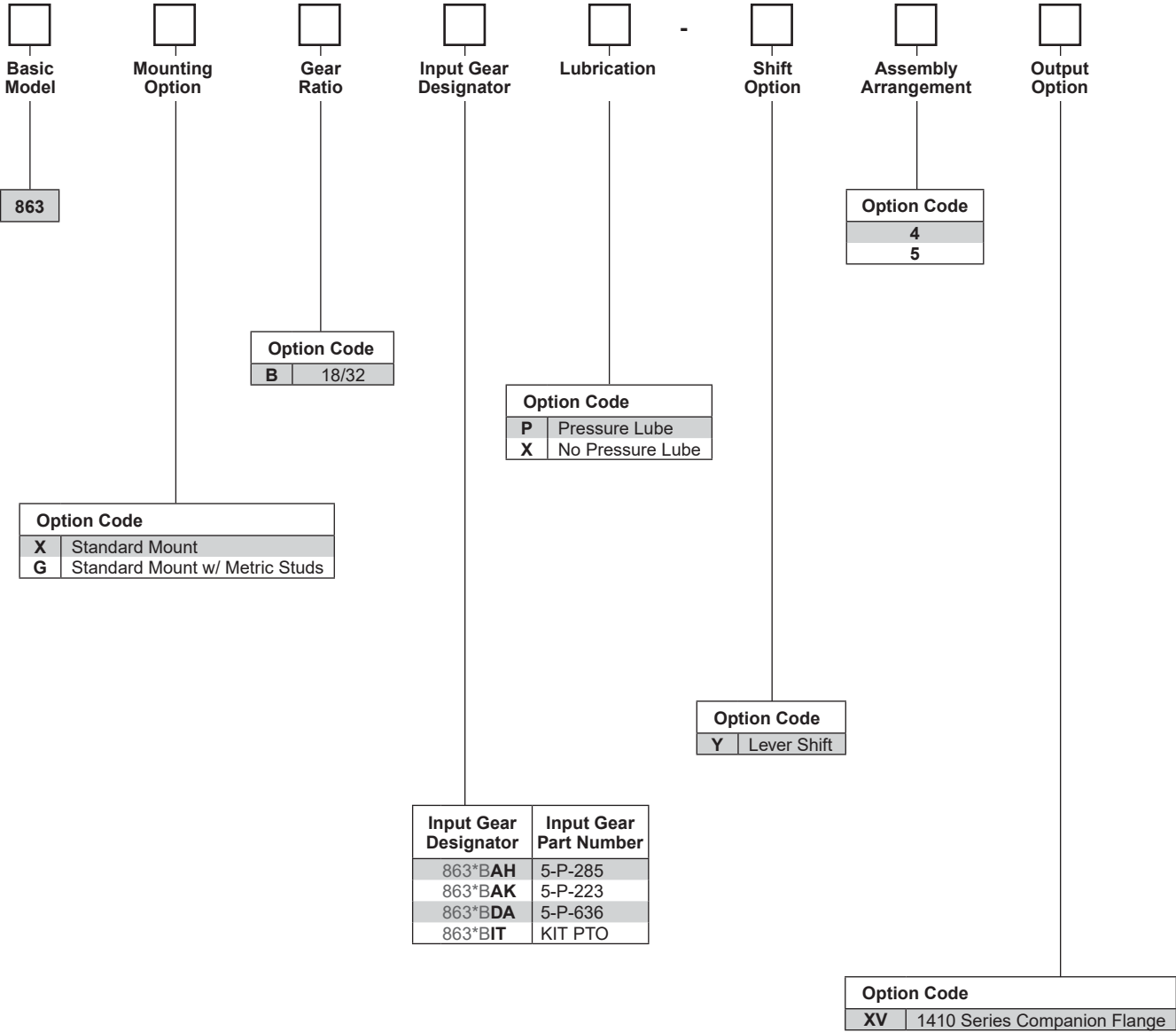

Assembly

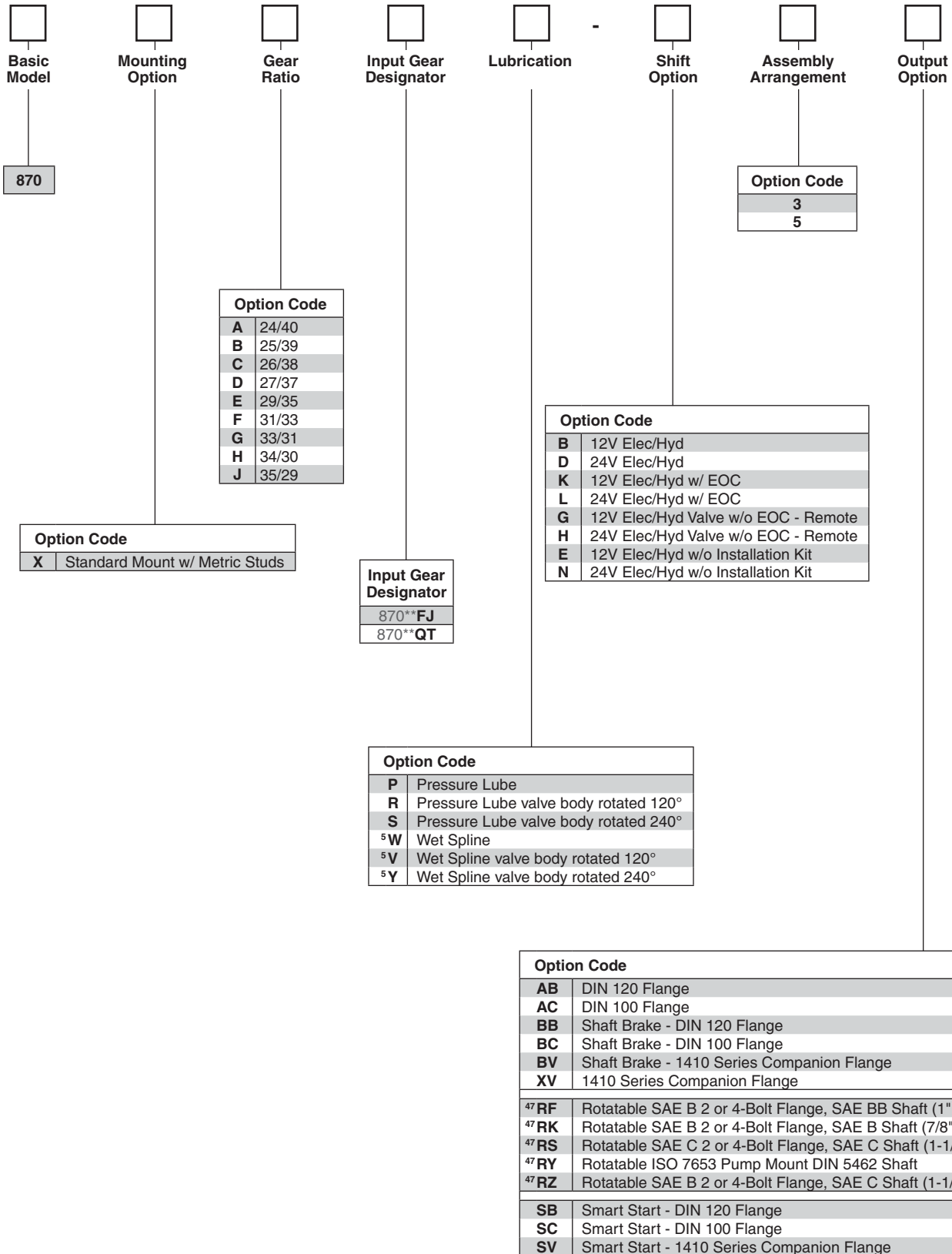

⁵ Automatically pressure lubed

⁴⁷ Available with Wet Spline

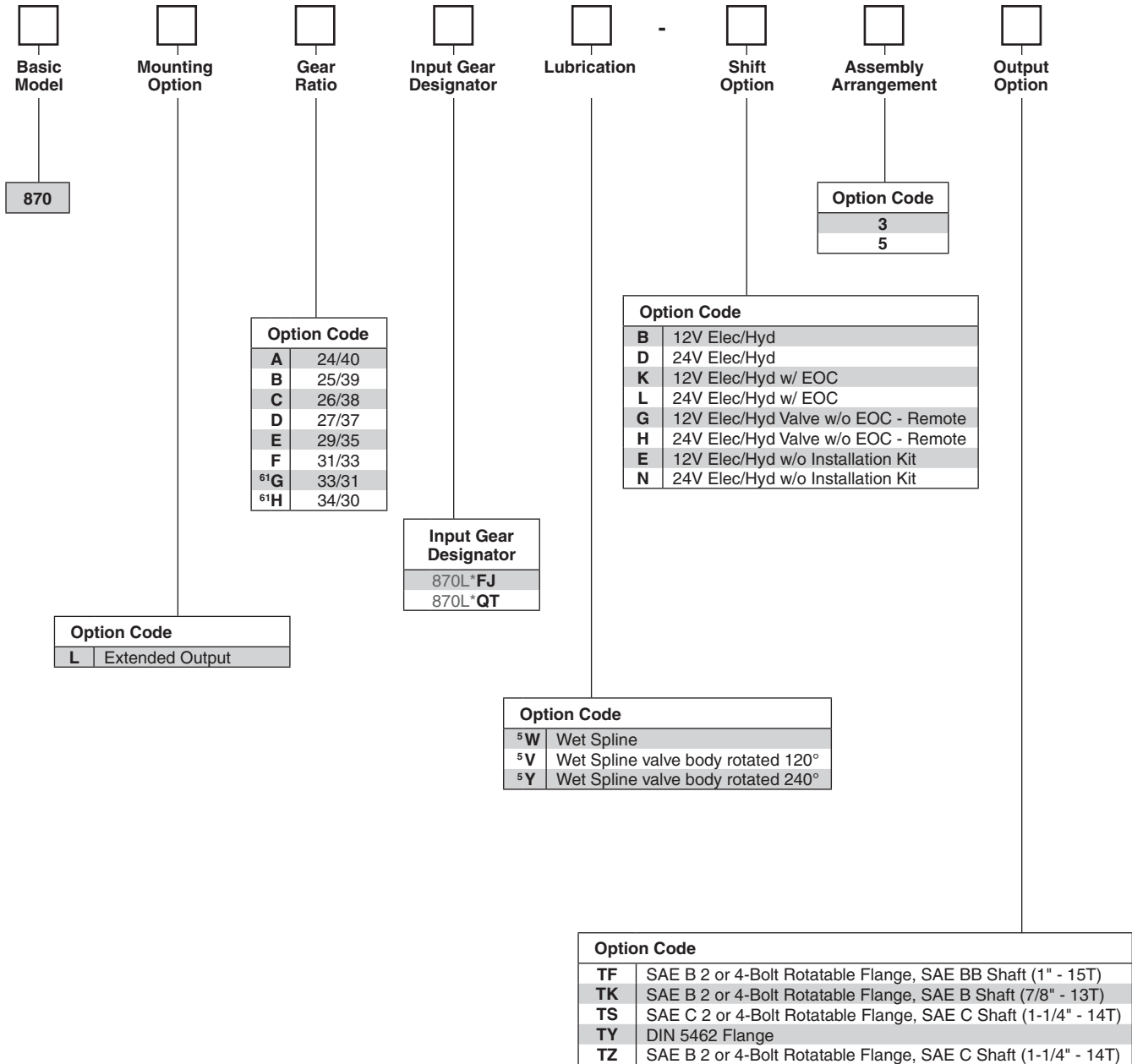

Assembly

⁵ Automatically pressure lubed

⁶¹ For the Allison 4000 Series Engineering Approval required

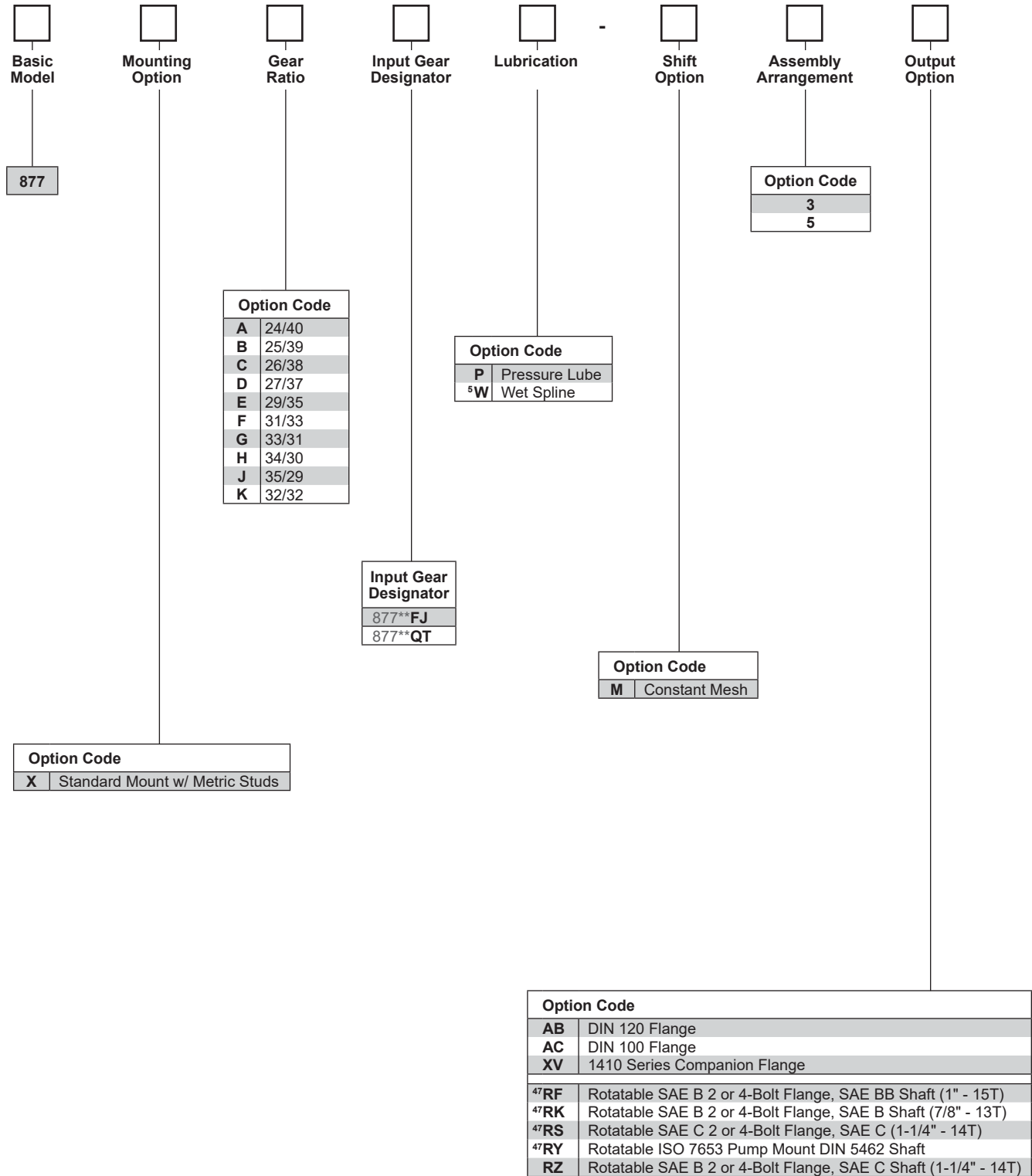

Assembly

⁵ Automatically pressure lubed

⁴⁷ Available with Wet Spline

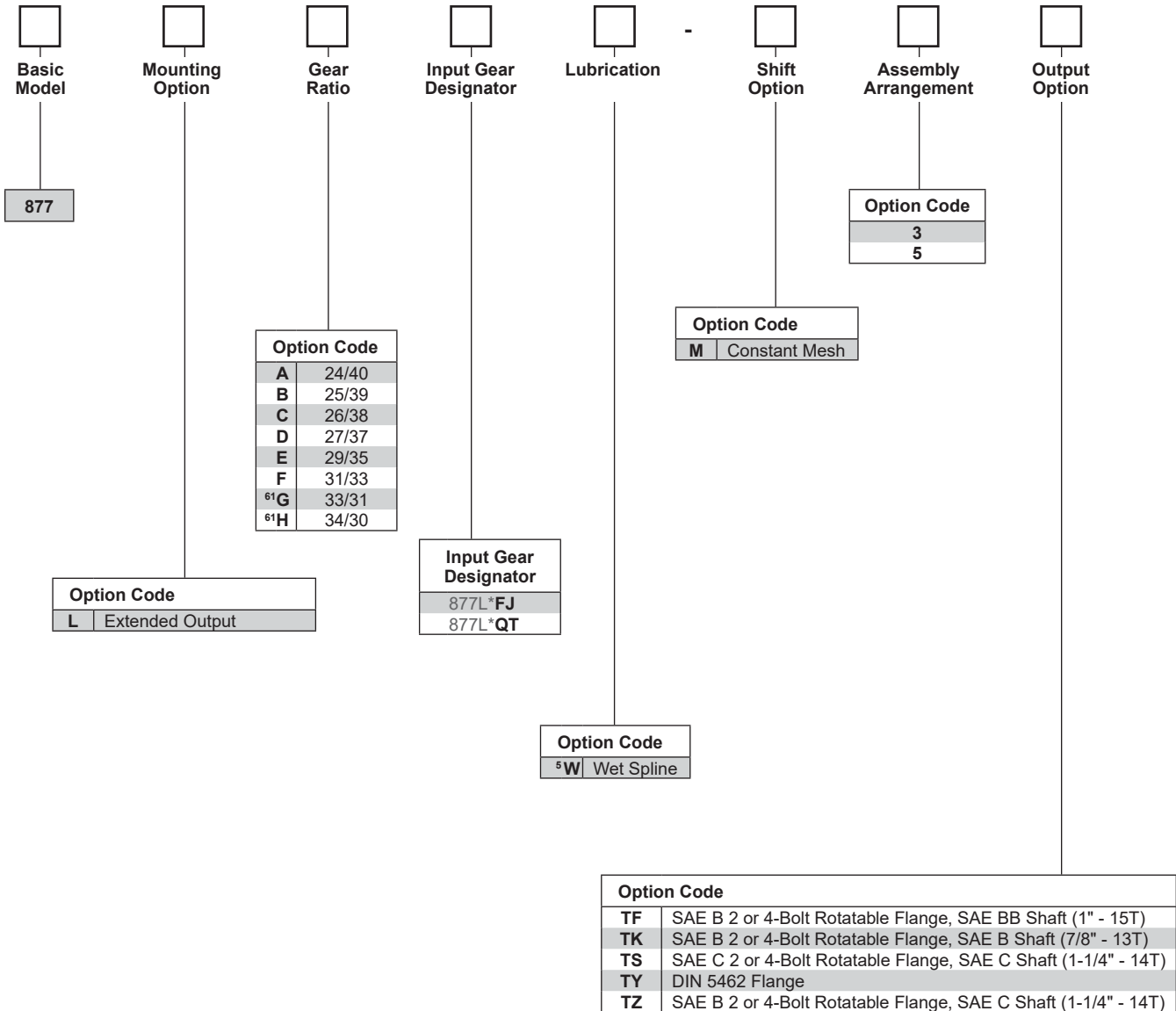

Assembly

⁵ Automatically pressure lubed

⁶¹ For the Allison 4000 Series Engineering Approval required

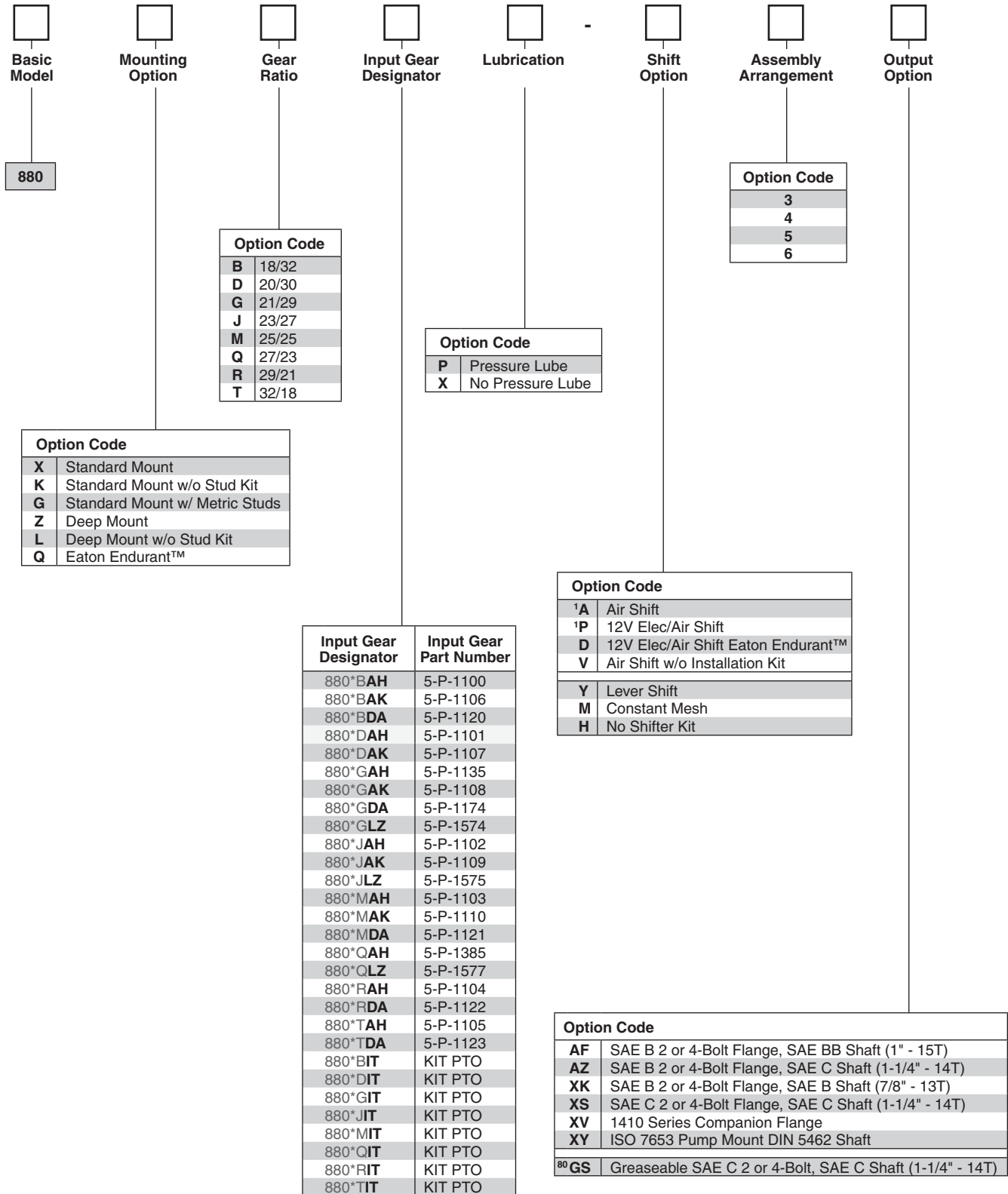

Assembly

¹ Includes mounting parts

⁸⁰ No Pressure Lube Only

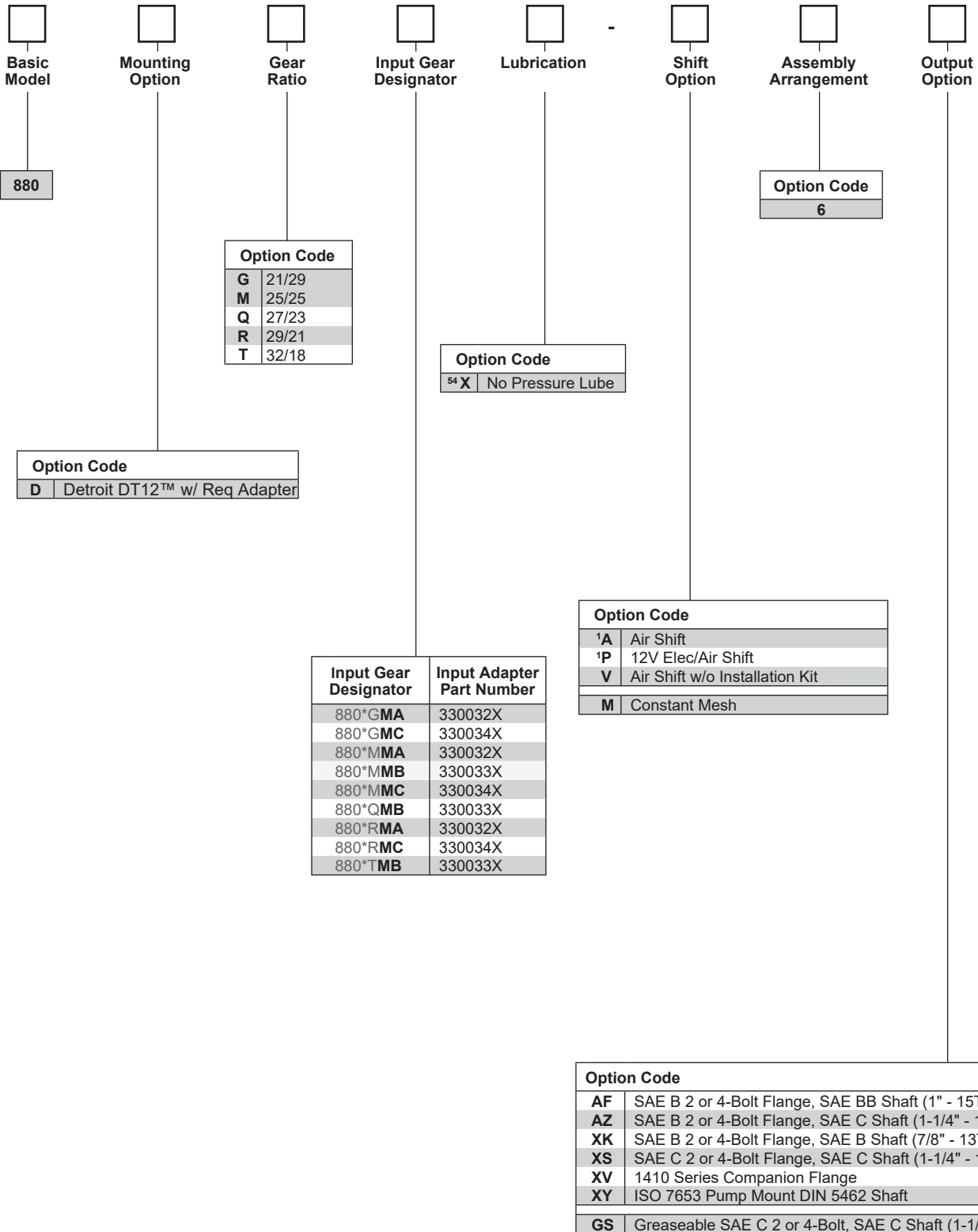

Assembly

¹ Includes mounting parts

⁵⁴ X Lube option only

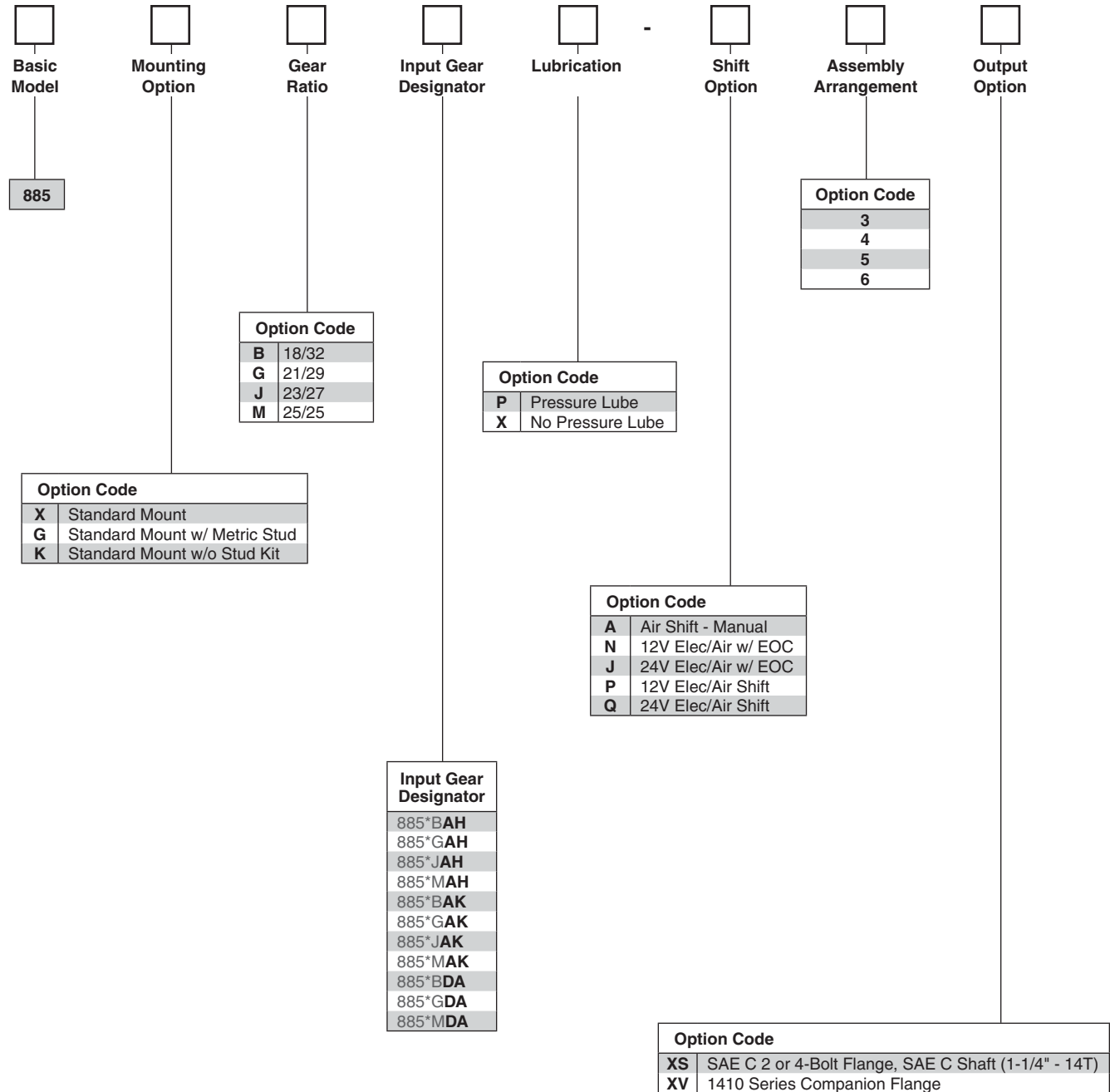

Assembly

Assembly

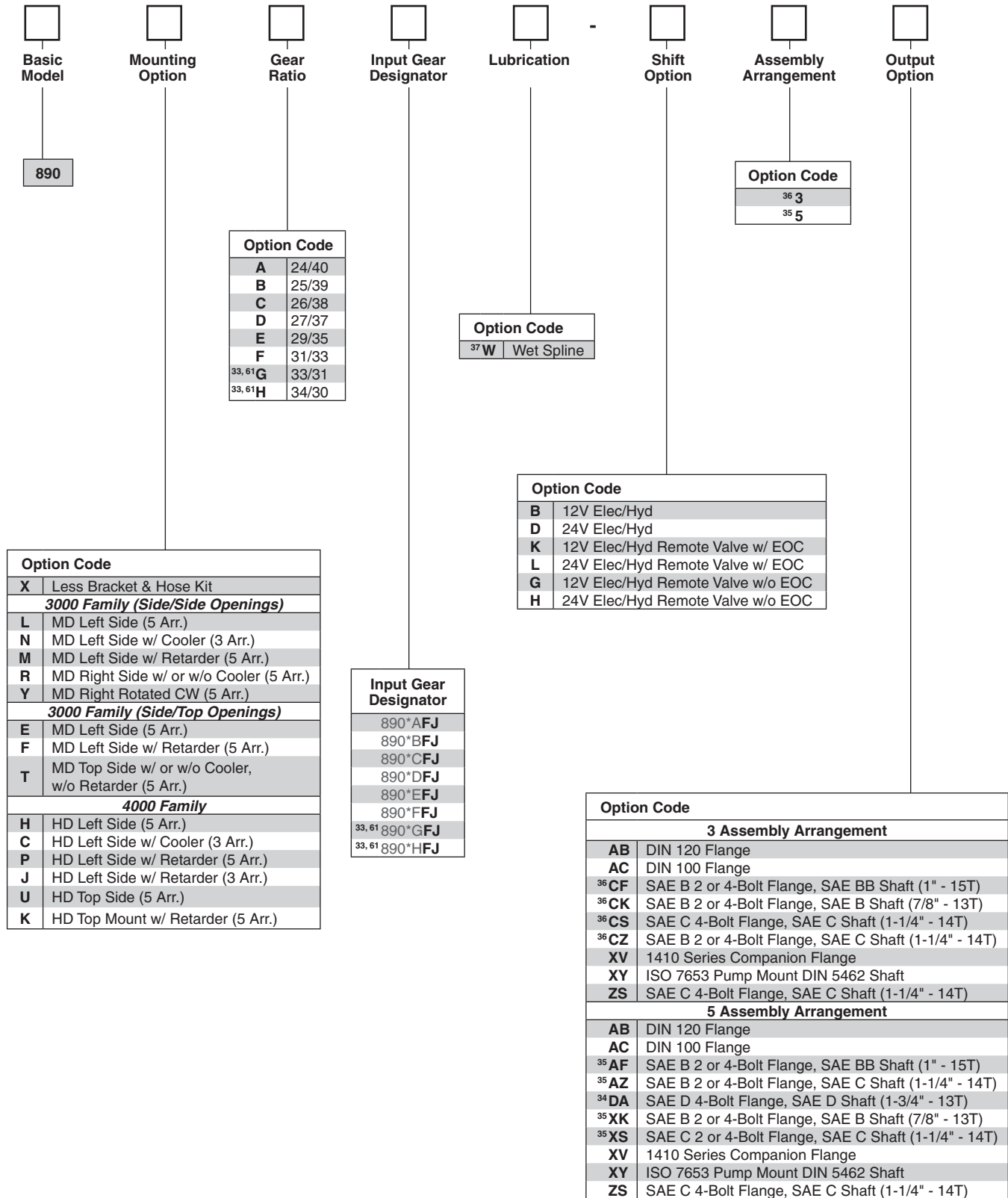

³³ G & H ratio for Allison 3000 Series only
³⁴ DA output is not available for transmission with a retarder or cooler
³⁵ XS, XK, AF, AZ outputs available with 5 ass'y arrangement
³⁶ CS, CK, CF, CZ outputs only available with 3 ass'y arrangement
³⁷ Automatically pressure lubed with Wet Spline
⁶¹ For the Allison 4000 Series Engineering Approval required

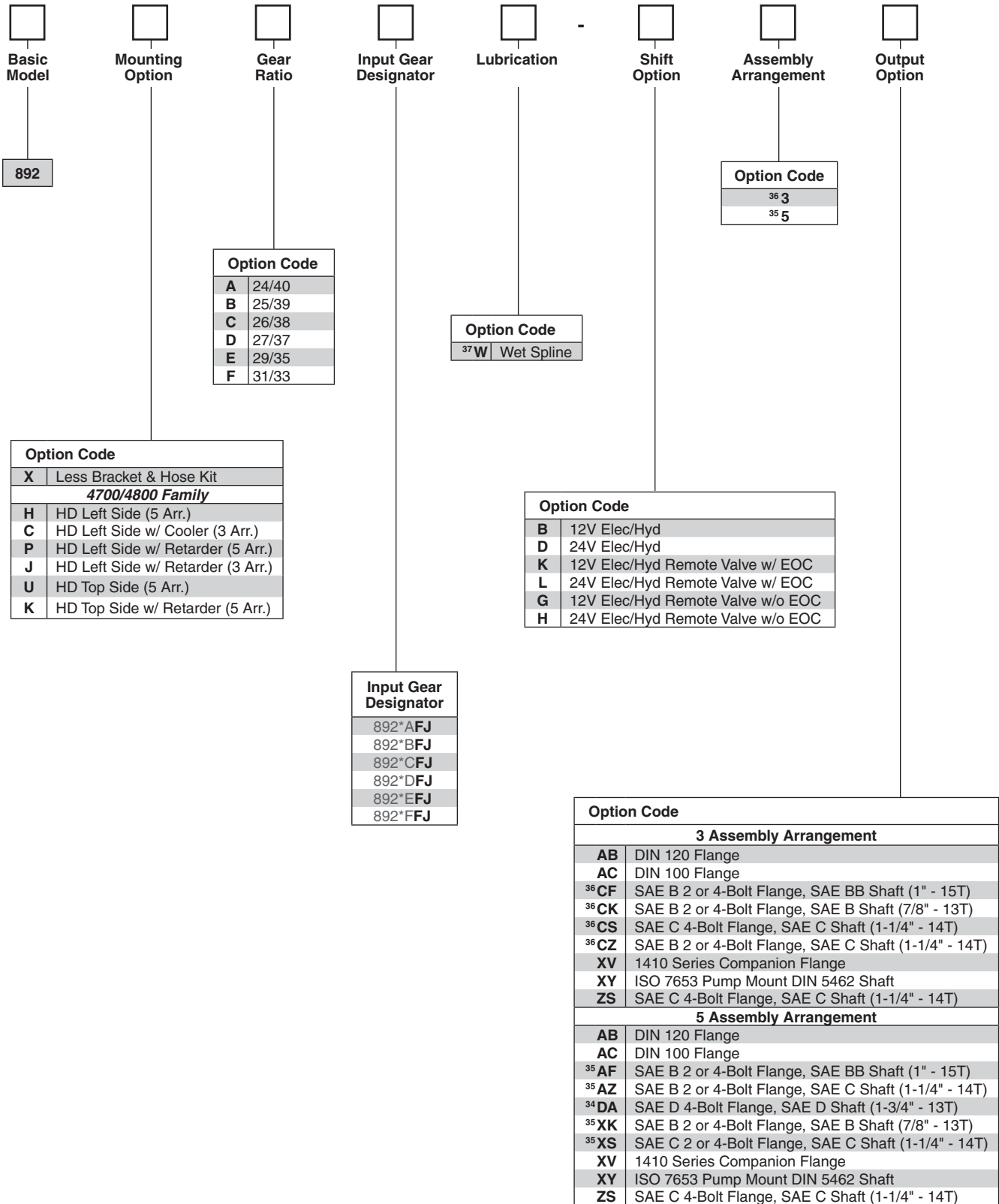

³⁴ DA output is not available for transmission with a retarder or cooler

³⁵ XS, XK, AF, AZ outputs available with 5 ass'y arrangement

³⁶ CS, CK, CF, CZ outputs only available with 3 ass'y arrangement

³⁷ Automatically pressure lubed with Wet Spline

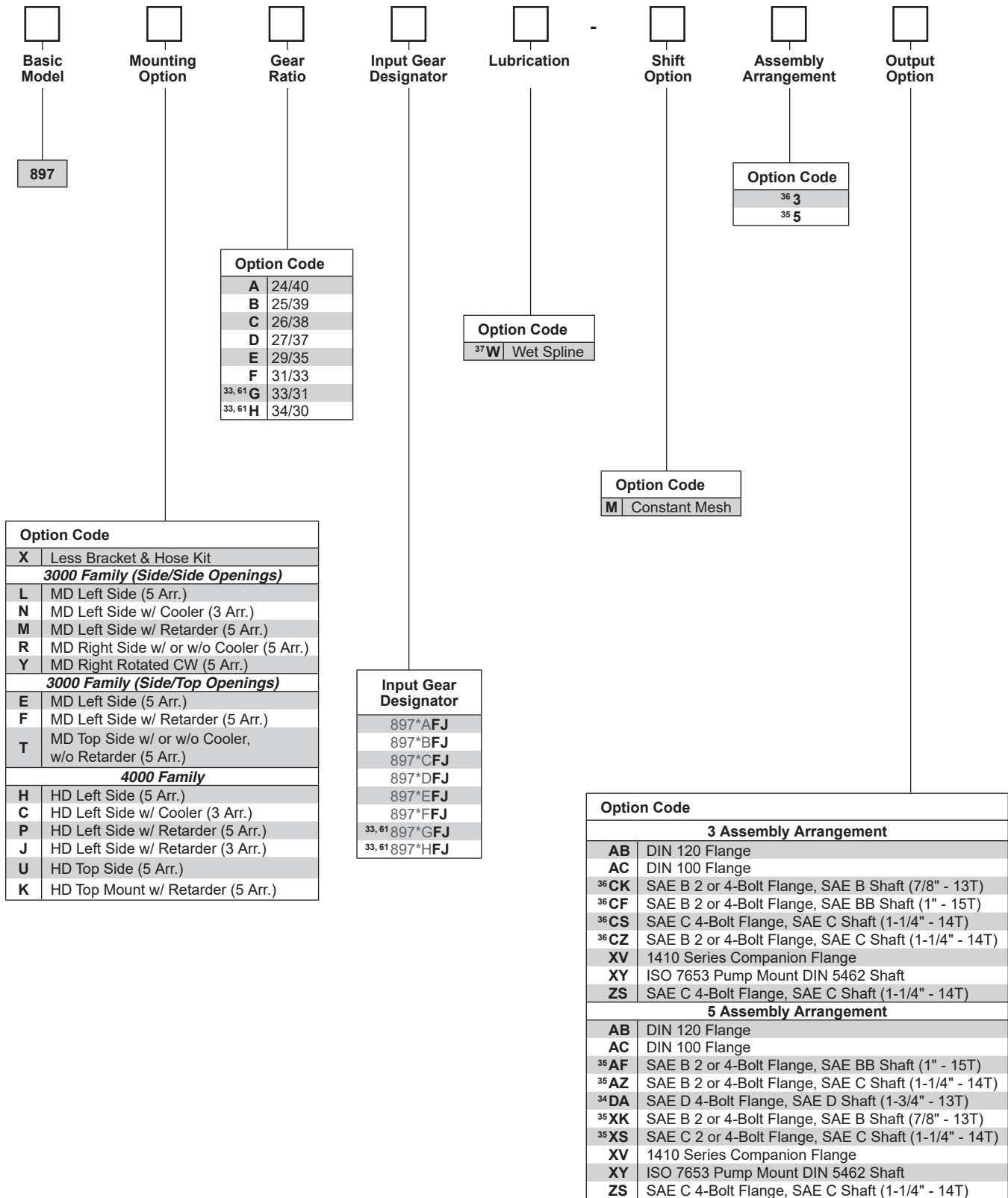

Assembly

³³ G & H ratio for Allison 3000 Series only
³⁴ DA output is not available for transmission with a retarder or cooler
³⁵ XS, XK, AF, AZ outputs available with 5 ass'y arrangement
³⁶ CS, CK, CF, CZ outputs only available with 3 ass'y arrangement
³⁷ Automatically pressure lubed with Wet Spline
⁶¹ For the Allison 4000 Series Engineering Approval required

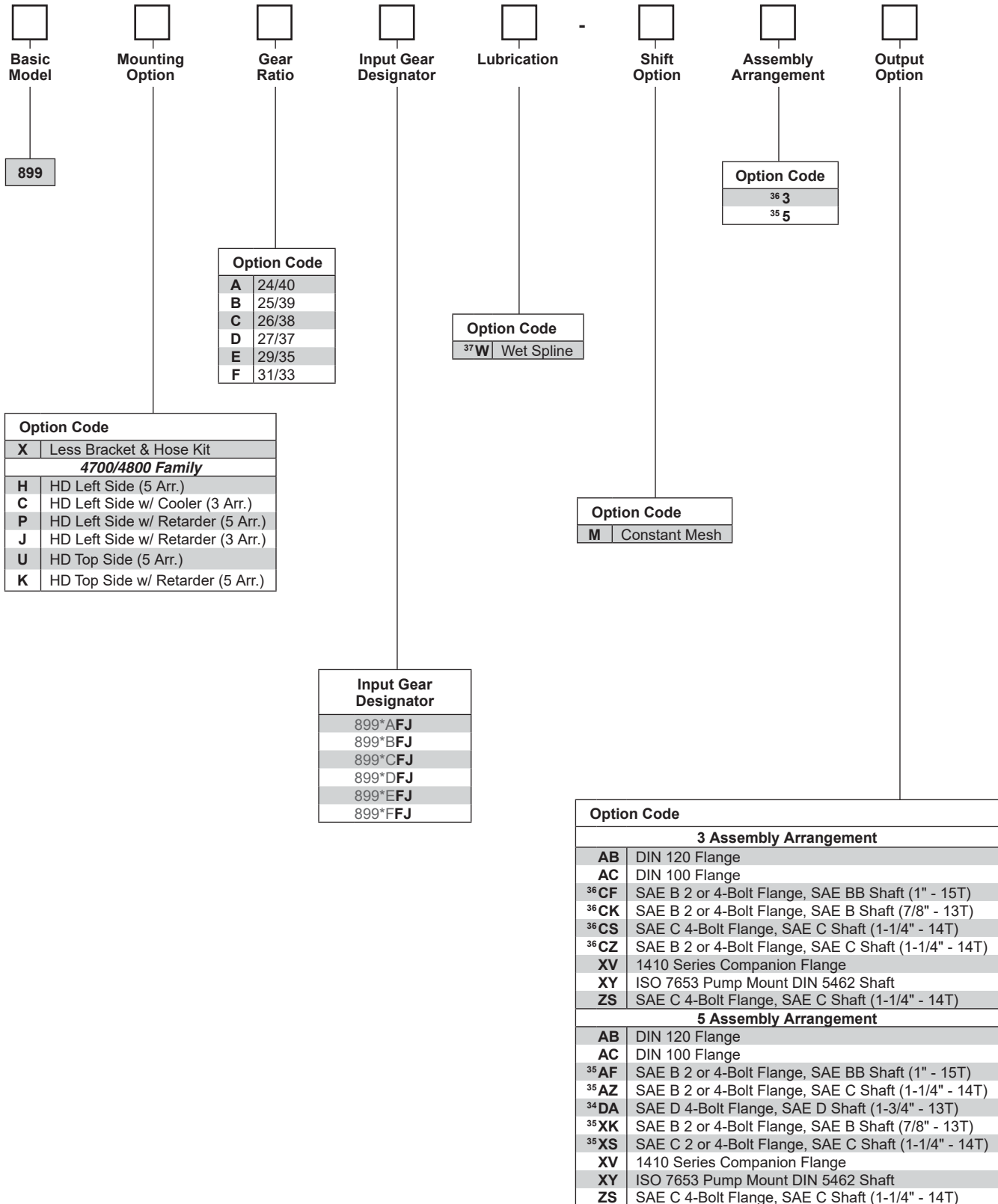

Assembly

³⁴ DA output is not available for transmission with a retarder or cooler

³⁵ XS, XK, AF, AZ outputs available with 5 ass'y arrangement

³⁶ CS, CF, CZ outputs only available with 3 ass'y arrangement

³⁷ Automatically pressure lubed with Wet Spline

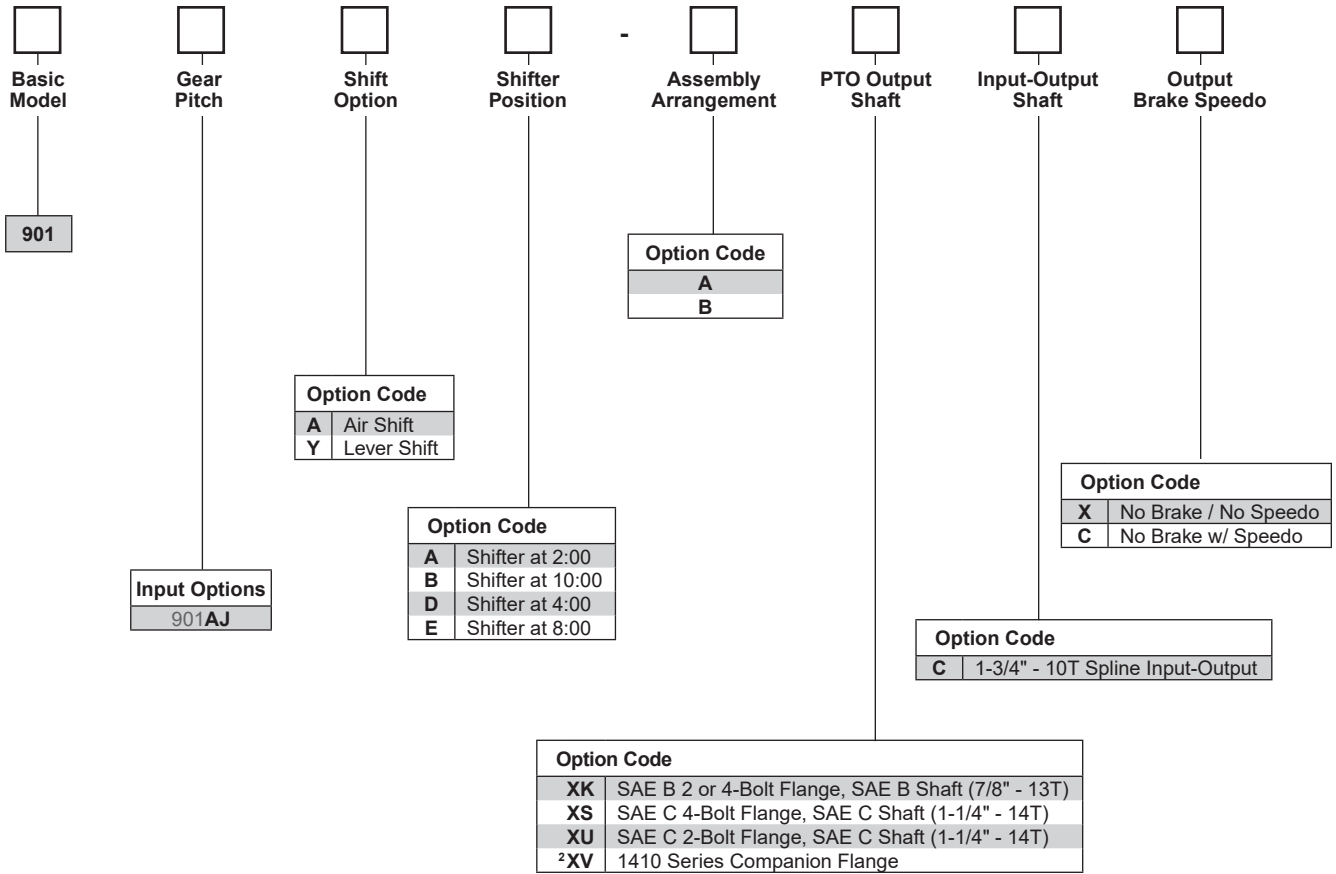

Assembly

² Standard shaft

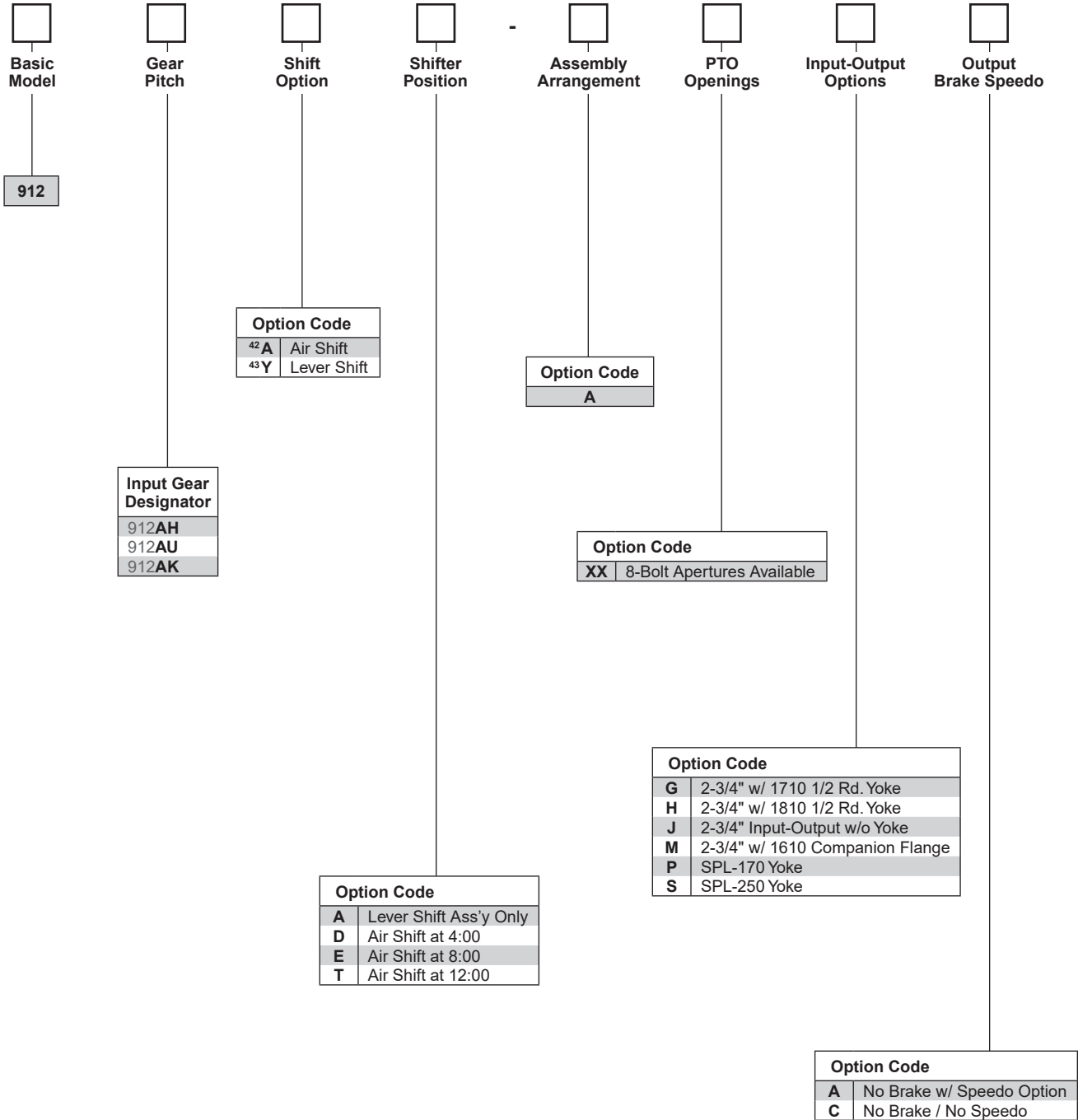

Assembly

⁴² Air Shift, two 8-Bolt opening available
⁴³ Lever Shift, three 8-Bolt opening available



Option Code	
F	21/37
L	25/34
Q	19/24
S	24/22
U	26/20
W	26/17
X	38/21

Option Code	
1	Output Opposite Input
2	Output Same Side as Input

Option Code	
¹ A	Air Shift
¹ P	12V Elec/Air Shift
²¹ S	Air Shift w/ PTO/Dump Pump Combo Valve w/ Kick Out w/ Neutral Spring Return
²¹ T	Air Shift w/ PTO/Dump Pump Combo Valve w/o Kick Out w/ Neutral Spring Return
²¹ U	Air Shift w/ PTO/Dump Pump Combo Valve w/ Kick Out w/o Neutral Spring Return
V	Air Shift w/o Installation Kit
¹ W	Cable Shift
X	Wire Shift w/o Cable & Knob
C	Heavy Duty Bracket Less Cable
H	No Shift Assembly
M	Constant Mesh

Option Code	
AF	SAE B 2 or 4-Bolt Flange, SAE BB Shaft (1" - 15T)
AK	SAE B 2-Bolt Flange, SAE B Shaft (7/8" - 13T)
AZ	SAE B 4-Bolt Flange, SAE C Shaft (1-1/4" - 14T)
SQ	SAE B 4-Bolt Flange, SAE B Shaft (7/8" - 13T)
XD	Rd Standard Shaft (1-1/4" - 5/16" Key)
XE	SAE A 2 or 4-Bolt Flange, SAE A Shaft (5/8" - 9T)
XK	SAE B 2 or 4-Bolt Flange, SAE B Shaft (7/8" - 13T)
⁵⁹ XQ	SAE B 2 or 4-Bolt Flange, SAE B Shaft (7/8" - 13T)
XR	Chelsea Special (Cloverleaf), SAE B Shaft (7/8" - 13T)
XX	1-1/4" Tapered Output Shaft w/ Keyway
XY	ISO 7653 Pump Mount DIN 5462 Shaft
RA	Rotatable SAE B 2-Bolt Flange, SAE B Shaft (7/8" - 13T)
RB	Rotatable SAE B 4-Bolt Flange, SAE B Shaft (7/8" - 13T)
RC	Rotatable SAE A 2-Bolt Flange, SAE A Shaft (5/8" - 9T)
RD	Rotatable SAE A 2-Bolt Flange, SAE B Shaft (7/8" - 13T)
RE	Rotatable SAE B 4-Bolt Flange, SAE BB Shaft (1" - 15T)
RF	Rotatable SAE B 2-Bolt Flange, SAE BB Shaft (1" - 15T)
RK	Rotatable SAE B 2 or 4-Bolt Flange, SAE B Shaft (7/8" - 13T)
RY	Rotatable ISO 7653 Pump Mount DIN 5462 Shaft
GA	Greaseable SAE B 2-Bolt Rotatable Flange, SAE B Shaft (7/8" - 13T)
GB	Greaseable SAE B 4-Bolt Rotatable Flange, SAE B Shaft (7/8" - 13T)
GF	Greaseable SAE B 2 or 4-Bolt Flange, SAE BB Shaft (1" - 15T)
GK	Greaseable SAE B 2 or 4-Bolt Flange, SAE B Shaft (7/8" - 13T)
⁵⁹ GQ	Greaseable SAE B 2 or 4-Bolt Flange, SAE B Shaft (7/8" - 13T)
GR	Greaseable Chelsea Special (Cloverleaf), SAE B Shaft (7/8" - 13T)

¹ Includes mounting parts

²¹ Includes installation kit, console sold separately

⁵⁹ Same as XK except rotated 90°

Assembly

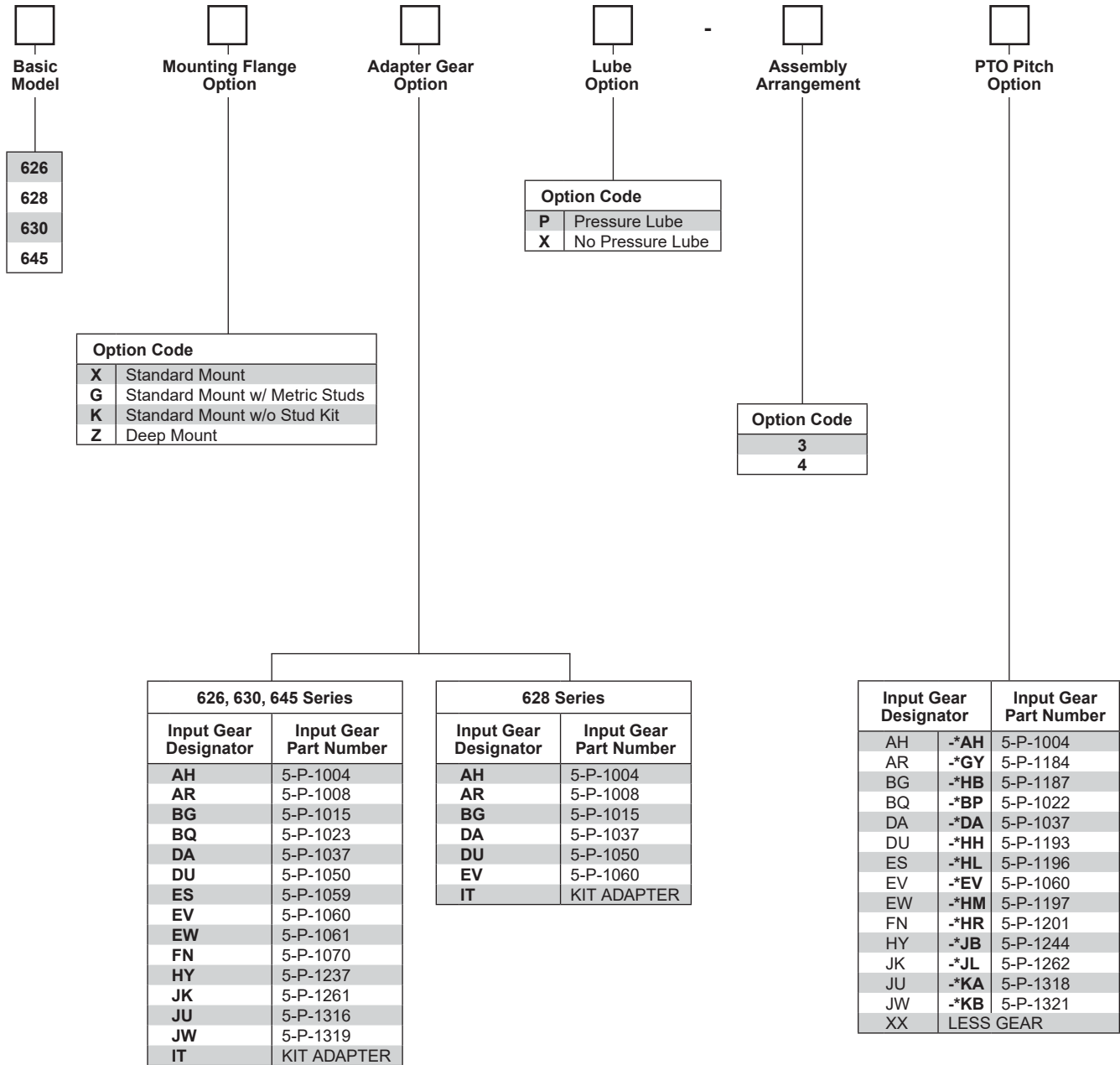

Assembly

NOTES



Assembly

APPLICATIONS



**WARNING — User Responsibility**

FAILURE OR IMPROPER SELECTION OR IMPROPER USE OF THE PRODUCTS DESCRIBED HEREIN OR RELATED ITEMS CAN CAUSE DEATH, PERSONAL INJURY AND PROPERTY DAMAGE.

This document and other information from Parker Hannifin Corporation, its subsidiaries and authorized distributors provide product or system options for further investigation by users having technical expertise.

The user, through its own analysis and testing, is solely responsible for making the final selection of the system and components and assuring that all performance, endurance, maintenance, safety and warning requirements of the application are met. The user must analyze all aspects of the application, follow applicable industry standards, and follow the information concerning the product in the current product catalog and in any other materials provided from Parker or its subsidiaries or authorized distributors.

To the extent that Parker or its subsidiaries or authorized distributors provide component or system options based upon data or specifications provided by the user, the user is responsible for determining that such data and specifications are suitable and sufficient for all applications and reasonably foreseeable uses of the components or systems.

Offer of Sale

The items described in this document are hereby offered for sale by Parker Hannifin Corporation, its subsidiaries or its authorized distributors. This offer and its acceptance are governed by the provisions stated in the "Offer of Sale".



WARNING: This product can expose you to chemicals including Lead and Lead Compounds, and Di(2-ethylhexyl)phthalate (DEHP) which are known to the State of California to cause cancer and birth defects or other reproductive harm. For more information go to www.P65Warnings.ca.gov

© Copyright 2022, Parker Hannifin Corporation, All Rights Reserved

Aisin.....	5.1.1 thru 5.1.6
Allison.....	5.2.1 thru 5.2.74
Chelsea.....	5.3.1 thru 5.3.6
Dodge/RAM.....	5.4.1 thru 5.4.10
Eaton Fuller.....	5.5.1 thru 5.5.94
Ford.....	5.6.1 thru 5.6.18
GM.....	5.7.1 thru 5.7.6
Hino.....	5.8.1 thru 5.8.8
Isuzu.....	5.9.1 thru 5.9.6
Mack.....	5.10.1 thru 5.10.48
Mercedes/Daimler/Detroit.....	5.11.1 thru 5.11.14
Meritor/Rockwell.....	5.12.1 thru 5.12.26
Paccar.....	5.13.1 thru 5.13.4
Tremec/TTC/Spicer.....	5.14.1 thru 5.14.18
Volvo.....	5.15.1 thru 5.15.8
ZF.....	5.16.1 thru 5.16.36

AISIN

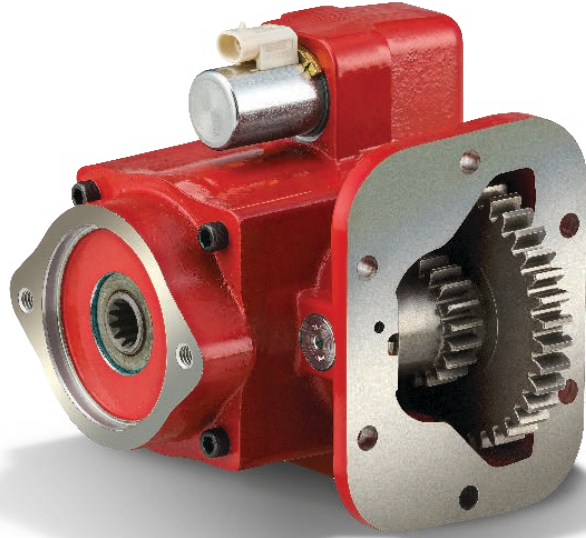
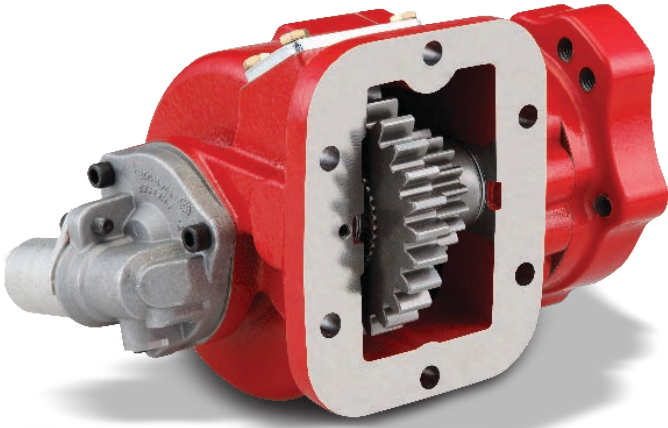

Parker | Chelsea

ENGINEERING YOUR SUCCESS.

**WARNING — User Responsibility**

FAILURE OR IMPROPER SELECTION OR IMPROPER USE OF THE PRODUCTS DESCRIBED HEREIN OR RELATED ITEMS CAN CAUSE DEATH, PERSONAL INJURY AND PROPERTY DAMAGE.

This document and other information from Parker Hannifin Corporation, its subsidiaries and authorized distributors provide product or system options for further investigation by users having technical expertise.

The user, through its own analysis and testing, is solely responsible for making the final selection of the system and components and assuring that all performance, endurance, maintenance, safety and warning requirements of the application are met. The user must analyze all aspects of the application, follow applicable industry standards, and follow the information concerning the product in the current product catalog and in any other materials provided from Parker or its subsidiaries or authorized distributors.

To the extent that Parker or its subsidiaries or authorized distributors provide component or system options based upon data or specifications provided by the user, the user is responsible for determining that such data and specifications are suitable and sufficient for all applications and reasonably foreseeable uses of the components or systems.

Offer of Sale

The items described in this document are hereby offered for sale by Parker Hannifin Corporation, its subsidiaries or its authorized distributors. This offer and its acceptance are governed by the provisions stated in the "Offer of Sale".



WARNING: This product can expose you to chemicals including Lead and Lead Compounds, and Di(2-ethylhexyl)phthalate (DEHP) which are known to the State of California to cause cancer and birth defects or other reproductive harm. For more information go to www.P65Warnings.ca.gov

© Copyright 2022, Parker Hannifin Corporation, All Rights Reserved

Transmission Make and Model	PTO Appl. Number	Number Forward Speeds	Teeth in PTO Driver
A443E	AIS-1	4	L58
A445	AIS-1	4	L58
A460 (Isuzu Number for MY400)	AIS-4	6	L63
A465 (Isuzu Number for MY600)	AIS-2	6	L69
A465HD	AIS-5	6	L69
A465ID	AIS-5	6	L69
A860E (Hino Number for MY400)	AIS-4	6	L63
A860F (Hino Number for MY400)	AIS-4	6	L63
MO35A4 (Mitsubishi/Fuso)	AIS-1	4	L58
MO36A6 (Mitsubishi/Fuso Number for MY600)	AIS-2	6	L69
MY400	AIS-4	6	L63
MY600	AIS-2	6	L69



IMPORTANT: See Safety Information in Section 1 of the Chelsea Applications catalog HY25-3000/US

Transmission PTO Driver & Apertures (Viewed from Rear of Transmission)
L-Left Side R-Right Side B-Bottom Side T-Top Side CS-Countershaft
For transmissions not listed, contact your authorized Chelsea Distributor.

AIS-1

AISIN

CHELSEA®

A443E
A445
MO35A4 (Mitsubishi/Fuso)

LEFT SIDE ONLY

TRANSMISSION GEAR DATA:

L.S. 06-BOLT Opening Gear FORWARD of Centerline
58 Teeth - SPUR

PITCH LINE TO APERTURE FACE:

1.0880" (27.6352MM)

CAUTION: Application Approval Required for PTO Output Shaft Speeds Above 2500 RPM

PTO Model	Torq	Dir Rot	Engine %		Filler Block	Adapter Assy	Stud Kit	PTO Model	Torq	Dir Rot	Engine %		Filler Block	Adapter Assy	Stud Kit
	I / C †		Fwd	Rev					I / C †		Fwd	Rev			

ONE SPEED - TWO GEAR POWERSHIFT (AIR OR HYDRAULIC)

272AAKUP-*5 (1)	199 C	Eng	58				Furnished
272ABKUP-*5 (2)	162 C	Eng	71				Furnished
272ACKUP-*5 (3)	134 C	Eng	86				Furnished
272ADKUP-*5 (4)	112 C	Eng	103				Furnished

† I = Intermittent Torque Only - De-rate Torque Rating 30% for Continuous Duty.

C = Continuous or Intermittent Torque - No need to De-Rate Torque Rating.

IMPORTANT: Refer to the back of this transmission section and read all notes associated with this application page. Some notes may affect the proper PTO selection.

Aisin

- (1) Input Gear Part No. 5-P-1515-1X
- (2) Input Gear Part No. 5-P-1515-2X
- (3) Input Gear Part No. 5-P-1515-3X
- (4) Input Gear Part No. 5-P-1515-4X

CHELSEA®

AISIN

AIS-2

A465 (Isuzu Number for MY600)
MO36A6 (Mitsubishi/Fuso Number for MY600)
MY600

LEFT SIDE ONLY

TRANSMISSION GEAR DATA:

L.S. 06-BOLT Opening Gear FORWARD of Centerline
69 Teeth - SPUR

PITCH LINE TO APERTURE FACE:

1.0880" (27.6352MM)

CAUTION: Application Approval Required for PTO Output Shaft Speeds Above 2500 RPM

PTO Model	Torq	Dir Rot	Engine %		Filler Block	Adapter Assy	Stud Kit	PTO Model	Torq	Dir Rot	Engine %		Filler Block	Adapter Assy	Stud Kit
	I / C †		Fwd	Rev					I / C †		Fwd	Rev			

ONE SPEED - TWO GEAR POWERSHIFT (AIR OR HYDRAULIC)

272AAKUP-*5 (1)	158 C	Eng	69				Furnished
272ABKUP-*5 (2)	129 C	Eng	84				Furnished
272ACKUP-*5 (3)	106 C	Eng	102				Furnished
272ADKUP-*5 (4)	89 C	Eng	122				Furnished

† I = Intermittent Torque Only - De-rate Torque Rating 30% for Continuous Duty.

C = Continuous or Intermittent Torque - No need to De-Rate Torque Rating.

IMPORTANT: Refer to the back of this transmission section and read all notes associated with this application page. Some notes may affect the proper PTO selection.

- (1) Input Gear Part No. 5-P-1515-1X
- (2) Input Gear Part No. 5-P-1515-2X
- (3) Input Gear Part No. 5-P-1515-3X
- (4) Input Gear Part No. 5-P-1515-4X

AIS-4

AISIN

CHELSEA®

A460 (Isuzu Number for MY400)
A880E (Hino Number for MY400)
A880F (Hino Number for MY400)
MY400

LEFT SIDE ONLY

TRANSMISSION GEAR DATA:

L.S. 06-BOLT Opening Gear FORWARD of Centerline
63 Teeth - SPUR

PITCH LINE TO APERTURE FACE:

1.1" (27.6MM)

CAUTION: Application Approval Required for PTO Output Shaft Speeds Above 2500 RPM

PTO Model	Torq	Dir Rot	Engine %		Filler Block	Adapter Assy	Stud Kit	PTO Model	Torq	Dir Rot	Engine %		Filler Block	Adapter Assy	Stud Kit
	I / C †		Fwd	Rev					I / C †		Fwd	Rev			

ONE SPEED - TWO GEAR POWERSHIFT (AIR OR HYDRAULIC)

272AAKUP-*5 (1)	173 C	Eng	63				Furnished
272ABKUP-*5 (2)	141 C	Eng	77				Furnished
272ACKUP-*5 (3)	117 C	Eng	93				Furnished
272ADKUP-*5 (4)	97 C	Eng	111				Furnished

† I = Intermittent Torque Only - De-rate Torque Rating 30% for Continuous Duty.

C = Continuous or Intermittent Torque - No need to De-Rate Torque Rating.

IMPORTANT: Refer to the back of this transmission section and read all notes associated with this application page. Some notes may affect the proper PTO selection.

Aisin

- (1) Input Gear Part No. 5-P-1515-1X
- (2) Input Gear Part No. 5-P-1515-2X
- (3) Input Gear Part No. 5-P-1515-3X
- (4) Input Gear Part No. 5-P-1515-4X

CHELSEA®

AISIN

AIS-5

A465HD
A465ID

LEFT SIDE ONLY

TRANSMISSION GEAR DATA:

L.S. 06-BOLT Opening Gear FORWARD of Centerline
69 Teeth - SPUR

PITCH LINE TO APERTURE FACE:

1.0880" (27.6352MM)

CAUTION: Application Approval Required for PTO Output Shaft Speeds Above 2500 RPM

PTO Model	Torq	Dir Rot	Engine %		Filler Block	Adapter Assy	Stud Kit	PTO Model	Torq	Dir Rot	Engine %		Filler Block	Adapter Assy	Stud Kit
	I / C †		Fwd	Rev					I / C †		Fwd	Rev			

ONE SPEED - TWO GEAR POWERSHIFT (AIR OR HYDRAULIC)

272AAKUP-*5 (1)	196 C	Eng	69				Furnished
272ABKUP-*5 (2)	160 C	Eng	84				Furnished
272ACKUP-*5 (3)	132 C	Eng	102				Furnished
272ADKUP-*5 (4)	111 C	Eng	122				Furnished
272AGKUP-*5 (5)	93 C	Eng	145				Furnished
272AKKUP-*5 (6)	83 C	Eng	162				Furnished
272AMKUP-*5 (7)	74 C	Eng	181				Furnished
272APKUP-*5 (8)	67 C	Eng	203				Furnished

† I = Intermittent Torque Only - De-rate Torque Rating 30% for Continuous Duty.

C = Continuous or Intermittent Torque - No need to De-Rate Torque Rating.

IMPORTANT: Refer to the back of this transmission section and read all notes associated with this application page. Some notes may affect the proper PTO selection.

- (1) Input Gear Part No. 5-P-1515-1X
- (2) Input Gear Part No. 5-P-1515-2X
- (3) Input Gear Part No. 5-P-1515-3X
- (4) Input Gear Part No. 5-P-1515-4X
- (5) Input Gear Part No. 5-P-1515-5X
- (6) Input Gear Part No. 5-P-1515-6X
- (7) Input Gear Part No. 5-P-1515-7X
- (8) Input Gear Part No. 5-P-1515-8X

Aisin Notes

AIS-1

1. The torque ratings shown are based on the maximum allowable torque capacity of the PTO drive gear in the transmission.
-

AIS-2

1. The A465 (MY600) transmissions in Isuzu trucks started TCC Lock-up in PTO Mode in MY2010. The transmission build start dates were June 2010. The vehicle code for MY2010 is "VN60."
 2. The A460 (MY400) and A465 (MY600) share the same transmission housing and both have a "shelf" in the aperture that interferes with the ratio gear of the 272, starting with the K ratio. The older 270 series fit with higher ratios because the input ratio gear was not as wide.
-

AIS-4

1. The A460 (MY400) and A465 (MY600) share the same transmission housing and both have a "shelf" in the aperture that interferes with the ratio gear of the 272, starting with the K ratio. The older 270 series fit with higher ratios because the input ratio gear was not as wide.
-

AIS-5

1. The A465D (Isuzu Diesel) and A465HD (Hino Diesel) transmissions are available for MY20+

ALLISON

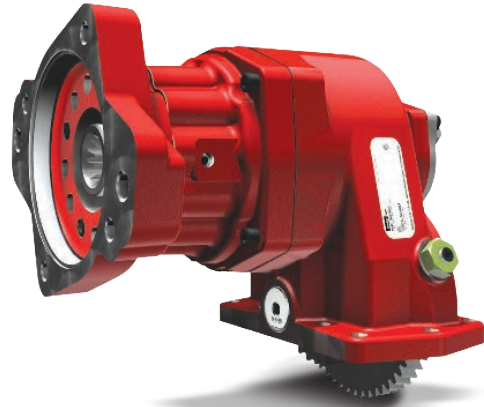
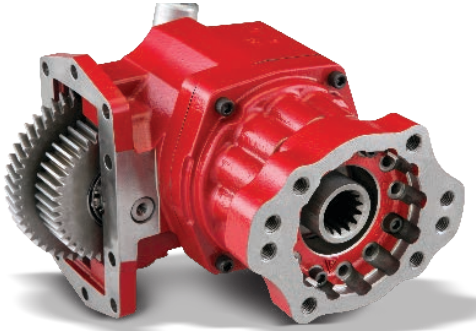
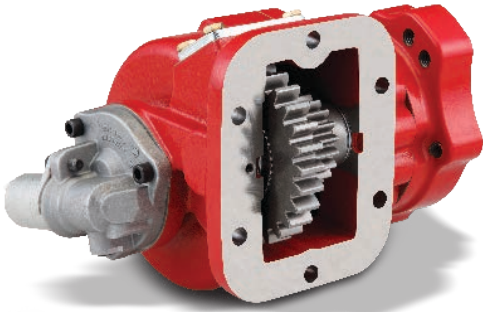

Parker | Chelsea

ENGINEERING YOUR SUCCESS.

**WARNING — User Responsibility**

FAILURE OR IMPROPER SELECTION OR IMPROPER USE OF THE PRODUCTS DESCRIBED HEREIN OR RELATED ITEMS CAN CAUSE DEATH, PERSONAL INJURY AND PROPERTY DAMAGE.

This document and other information from Parker Hannifin Corporation, its subsidiaries and authorized distributors provide product or system options for further investigation by users having technical expertise.

The user, through its own analysis and testing, is solely responsible for making the final selection of the system and components and assuring that all performance, endurance, maintenance, safety and warning requirements of the application are met. The user must analyze all aspects of the application, follow applicable industry standards, and follow the information concerning the product in the current product catalog and in any other materials provided from Parker or its subsidiaries or authorized distributors.

To the extent that Parker or its subsidiaries or authorized distributors provide component or system options based upon data or specifications provided by the user, the user is responsible for determining that such data and specifications are suitable and sufficient for all applications and reasonably foreseeable uses of the components or systems.

Offer of Sale

The items described in this document are hereby offered for sale by Parker Hannifin Corporation, its subsidiaries or its authorized distributors. This offer and its acceptance are governed by the provisions stated in the "Offer of Sale".



WARNING: This product can expose you to chemicals including Lead and Lead Compounds, and Di(2-ethylhexyl)phthalate (DEHP) which are known to the State of California to cause cancer and birth defects or other reproductive harm. For more information go to www.P65Warnings.ca.gov

© Copyright 2022, Parker Hannifin Corporation, All Rights Reserved

Allison Transmission Identification

In July 2005 Allison Transmission redesigned the transmission nameplates for all 1000/2000 and 3000/4000 Product Family transmissions. The new nameplate design contains only the information essential to the identification of the transmission. The transmission model number will no longer appear on the nameplate, it has been replaced by the serial number.

The transmission product family is identified by the first two digits of the transmission serial number:

Serial Number

63xxxxxxx
65xxxxxxx
66xxxxxxx

Product Family

1000 and 2000 Product Family
3000 Product Family
4000 Product Family

“SP” models will contain additional information to accommodate military applications. The transmission E-number is embossed on the “SP” models and when required for other models sold to the military. The transmission model number is embossed on the nameplate for “SP” model and “MD” and “HD” models sold to the military. The model number will not be embossed for any other model. (Ref: Allison Watch #335 Rev. A)

For further assistance contact Allison Technical Assistance at (800) 252-5283.

The Allison transmission serial number can be used to verify transmissions options. Use the link below to determine the options. Contact Allison Transmission for any questions regarding their options.
<https://www.allisontransmission.com/parts-service/my-transmission>

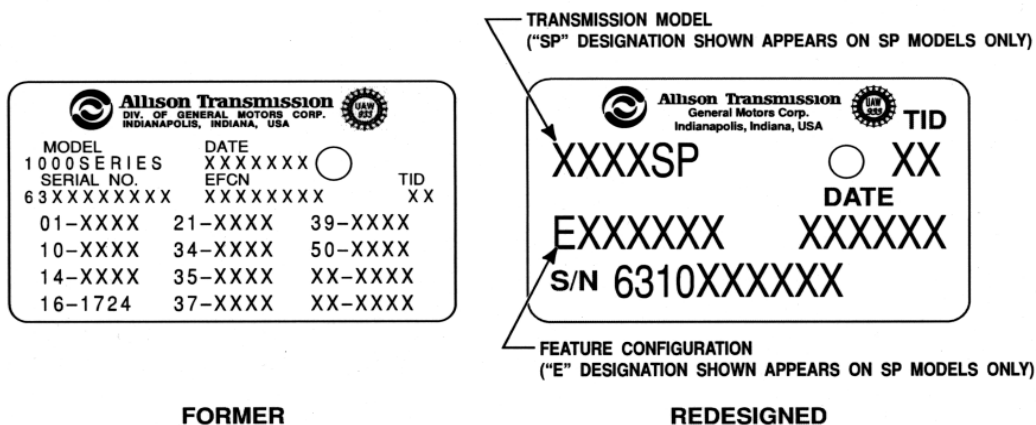

Figure 1. 1000 and 2000 Product Families Nameplates

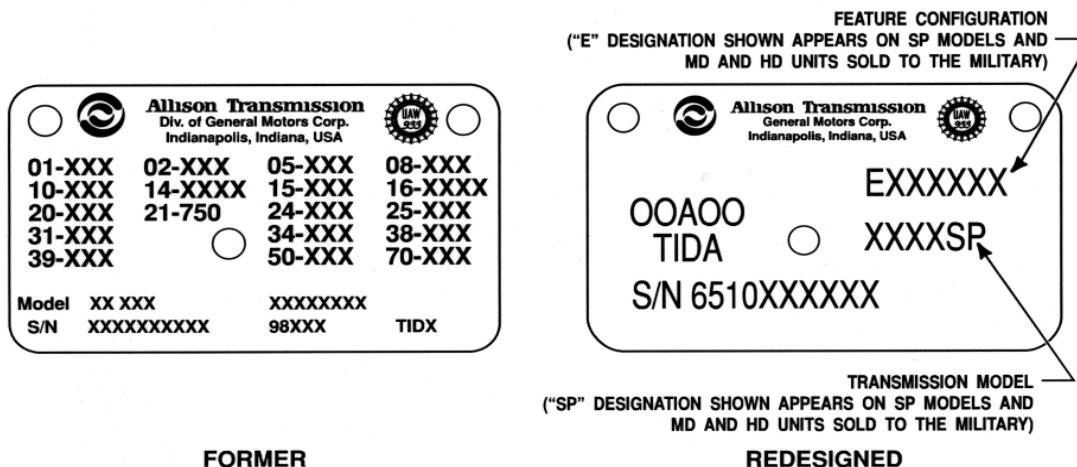

Figure 2. 3000 and 4000 Product Families Nameplates



ALLISON TRANSMISSION INDEX

890 Family Fitment to Transmission										
Application Page	Arr.	Mounting PTO Code	Transmission Location	Flange Options						
				XS	XK/AF/AZ	XY	DA	ZS/TS	CS/ES	CK/CF/CZ
3000 Series Side/Side										
All-13	5	L	Left side	L	L	L	L	L		
All-13	5	R	Right side	R	R	R	R	R		
All-13C	3	N	Left side w/ Cooler			N		N	N	N
All-13C	5	R	Right side w/ Cooler	R	R	R		R		
All-13R	5	M	Left side w/ Retarder	M	M	M				
All-13R	3	A	Left side w/ Retarder, and Cooler							
All-13R		N/A	Right side w/ Retarder							
3000 Series Side/Top										
All-16	5	E	Left side	E	E	E	E			
All-16	5	T	Right Top side	T	T	T	T			
All-16EV	5	E	Left side (w/o cooler or retarder)	E	E	E	E			
All-16EV	5	T	Right Top side (w/o cooler or retarder)	T	T	T	T			
All-16C	3	D	Left side w/ Cooler			D		D	D	D
All-16C	5	T	Right Top side w/ Cooler	T	T	T	T			
All-16R	5	F	Left side w/ Retarder	F	F	F				
All-16R	3	B	Left side w/ Retarder, and Cooler							
All-16R	5	G	Right Top side w/ Retarder							
4000 Series 6-Speed										
All-14	5	H	Left side	H	H	H	H			
All-14	5	U	Right Top side	U	U	U	U			
All-14C	3	C	Left side w/ Cooler			C		C	C	C
All-14C	5	U	Right Top side w/ Cooler	U	U	U	U			
All-14R	5	P	Left side w/ Retarder		P	P		P		
All-14R	3	J	Left side w/ Retarder			J		J	J	J
All-14R	5	K	Right Top side w/ Retarder	K	K	K				
4000 Series 7-Speed										
All-19	5	H	Left side	H	H	H	H			
All-19	5	U	Right Top side	U	U	U	U			
All-19C	3	C	Left side w/ Cooler			C		C	C	C
All-19C	5	U	Right Top side w/ Cooler	U	U	U	U			
All-19R	5	P	Left side w/ Retarder		P	P		P		
All-19R	3	J	Left side w/ Retarder			J		J	J	J
All-19R	5	K	Right Top side w/ Retarder	K	K	K				

N/A = No Application

Arr. = Assembly Arrangement

Transmission Make and Model	PTO Appl. Number	Number Forward Speeds	Teeth in PTO Driver
1000	ALL-15	5	L64-R64
1000 (GM 3600 Cab-Chassis)	ALL-17	5	R64
1000 EVS (Emergency Vehicles Only)	ALL-15	5	L64-R64
1000 MH (Motorhome)	ALL-15	5	L64-R64
1000 RDS (Rugged Duty Service)	ALL-15	5	L64-R64
1350 (Available in 4,5 & 6 Speed)	ALL-15	6	L64-R64
1350 EVS (Emergency Vehicles Only Available in 4,5 & 6 Speed)	ALL-15	6	L64-R64
1350 MH (Motorhome) (Available in 4,5 & 6 Speed)	ALL-15	6	L64-R64
1350 RDS (Rugged Duty Service Available in 4,5 & 6 Speed)	ALL-15	6	L64-R64
1350 SP (Specialty Series) (Available in 4,5 & 6 Speed)	ALL-15	6	L64-R64
1700	ALL-21	6	L64-R64
1750	ALL-21	6	L64-R64
2000	ALL-15	5	L64-R64
2100 EVS (Emergency Vehicles Only)	ALL-15	5	L64-R64
2100 MH (Motorhome)	ALL-15	5	L64-R64
2100 RDS (Rugged Duty Service)	ALL-15	5	L64-R64
2200 EVS (Emergency Vehicles Only)	ALL-15	5	L64-R64
2200 MH (Motorhome)	ALL-15	5	L64-R64
2200 RDS (Rugged Duty Service)	ALL-15	5	L64-R64
2300 RDS (Rugged Duty Service)	ALL-15	6	L64-R64
2400	ALL-15	5	L64-R64
2500 EVS (Emergency Vehicles Only)	ALL-15	5	L64-R64
2500 MH (Motorhome)	ALL-15	5	L64-R64
2500 RDS (Rugged Duty Service)	ALL-15	5	L64-R64
2700	ALL-21	6	L64-R64
2750	ALL-21	6	L64-R64
3000 (3000 Family - Side/Top PTO Provision w/ Retarder)	ALL-16R	6	L83-T83
3000 (3000 Family- Side/Side PTO Provision w/ Retarder)	ALL-13R	6	L68-R68
3000 (3000 Family Side/Top PTO Provision w/ Integral Cooler)	ALL-16C	6	L83-T83
3000 (3000 Family-Side/Side PTO Provision w/ Integral Cooler)	ALL-13C	6	L68-R68
3000 (Econic) (3000 Family-Side/Side PTO Provision w/ Integral Cooler Daimler Econic)	ALL-13EC	6	L68
3000 (International - Side/Side PTO Provision)	ALL-13	6	L68-R68
3000 (International - Side/Top PTO Provision)	ALL-16	6	L83-T83
3000 EVS (Emergency Vehicles Only Top/Side PTO Provisions)	ALL-16EV	6	L83-T83
3000 EVS (Emergency Vehicles Only Side/Side Power Take-Off Provisions)	ALL-13	6	L68-R68
3000 MH (Motorhome)	ALL-13	6	L68-R68



IMPORTANT: See Safety Information in Section 1 of the Chelsea Applications catalog HY25-3000/US

Transmission PTO Driver & Apertures (Viewed from Rear of Transmission)
L-Left Side R-Right Side B-Bottom Side T-Top Side CS-Countershaft
For transmissions not listed, contact your authorized Chelsea Distributor.

ALLISON TRANSMISSION INDEX

Transmission Make and Model	PTO Appl. Number	Number Forward Speeds	Teeth in PTO Driver
3000 ORS (Off Road Service Side/Side Power Take Off - Provisions)	ALL-13	6	L68-R68
3000 ORS (Off Road Service Side/Top PTO Provision)	ALL-16	6	L83-T83
3000 RDS (Rugged Duty Service)	ALL-13	6	L68-R68
3000 RDS (Rugged Duty Service Side/Top PTO Provision)	ALL-16	5	L83-T83
3000 SP (Specialty Series) (Side/Side PTO Option)	ALL-13	6	L68-R68
3000 SP (Specialty Series) (Side/Top PTO Provision)	ALL-16	6	L83-T83
3000 TRV (Truck RV)	ALL-13	6	L68-R68
3200 (International - Side/Side PTO Provision)	ALL-13	6	L68-R68
3200 (International - Side/Top PTO Provision)	ALL-16	6	L83-T83
3200 ORS (Off Road Service Side/Side PTO Provision)	ALL-13	6	L68-R68
3200 ORS (Off Road Service Side/Top PTO Provision)	ALL-16	6	L83-T83
3200 SP (Specialty Series) (Side/Side PTO Provision)	ALL-13	6	L68-R68
3200 SP (Specialty Series) (Side/Top PTO Provision)	ALL-16	6	L83-T83
3200 TRV (Truck RV)	ALL-13	6	L68-R68
3414	ALL-13	6	L68-R68
3500 (International - Side/Side PTO Provision)	ALL-13	6	L68-R68
3500 (International - Side/Top PTO Provision)	ALL-16	6	L83-T83
3500 EVS (Emergency Vehicles Only Top/Side PTO Provisions)	ALL-16EV	6	L83-T83
3500 EVS (Emergency Vehicles Only Side/Side Power Take-Off Provisions)	ALL-13	6	L68-R68
3500 OFS (Oil Field Service)	ALL-13	6	L68-R68
3500 ORS (Off Road Service Side/Side PTO Provision)	ALL-13	6	L68-R68
3500 ORS (Off Road Service Side/Top PTO Provision)	ALL-16	6	L83-T83
3500 RDS (Rugged Duty Service)	ALL-13	6	L68-R68
3500 RDS (Rugged Duty Service Side/Top PTO Provision)	ALL-16	6	L83-T83
3500 SP (Specialty Series) (Side/Side PTO Provision)	ALL-13	6	L68-R68
3500 SP (Specialty Series) (Side/Top PTO Provision)	ALL-16	6	L83-T83
3700	ALL-18	7	L68-R68
3700 SP (Specialty Series)	ALL-18	7	L68-R68
4000 (4000 Family w/ Integral Cooler)	ALL-14C	6	L97-T97
4000 (4000 Family w/ Retarder)	ALL-14R	6	L97-T97
4000 EVS (Emergency Vehicles Only)	ALL-14	6	L97-T97
4000 MH (Motorhome)	ALL-14	6	L97-T97
4000 RDS (Rugged Duty Service)	ALL-14	6	L97-T97
4000 TRV (Truck RV)	ALL-14	6	L97-T97
4430	ALL-14	6	L97-T97
4430 ORS (Off Road Service)	ALL-14	6	L97-T97
4430 SP (Specialty Series)	ALL-14	6	L97-T97

Allison



IMPORTANT: See Safety Information
in Section 1 of the Chelsea Applications
catalog HY25-3000/US

Transmission PTO Driver & Apertures (Viewed from Rear of Transmission)
L-Left Side R-Right Side B-Bottom Side T-Top Side CS-Countershaft
For transmissions not listed, contact your authorized Chelsea Distributor.

Transmission Make and Model	PTO Appl. Number	Number Forward Speeds	Teeth in PTO Driver
4440	ALL-14	6	L97-T97
4500 EVS (Emergency Vehicles Only)	ALL-14	6	L97-T97
4500 RDS (Rugged Duty Service)	ALL-14	6	L97-T97
4700	ALL-19	7	L97-T97
4700 (4700 Family w/ Integral Cooler)	ALL-19C	7	L97-T97
4700 (4700 Family w/ Retarder)	ALL-19R	7	L97-T97
4700 EVS (Emergency Vehicles Only)	ALL-19	7	L97-T97
4700 OFS (Oil Field Service)	ALL-19	7	L97-T97
4700 RDS (Rugged Duty Service)	ALL-19	7	L97-T97
4700 SP (Specialty Series)	ALL-19	7	L97-T97
4800	ALL-19	7	L97-T97
4800 (4800 Family w/ Integral Cooler)	ALL-19C	7	L97-T97
4800 (4800 Family w/ Retarder)	ALL-19R	7	L97-T97
4800 EVS (Emergency Vehicles Only)	ALL-19	7	L97-T97
4800 SP (Specialty Series)	ALL-19	7	L97-T97
4850 EVS (Emergency Vehicles Only)	ALL-19	7	L97-T97
5620 OFS (Oil Field Service)	ALL-8	6	R46-T46
6620 OFS (Oil Field Service)	ALL-8	6	R46-T46
6625 ORS (Off Road Service)	ALL-8	6	R46-T46
8610 OFS (Oil Field Service)	ALL-11	6	R59-T59
8610 ORS (Off Road Service)	ALL-11	6	R59-T59
8610 SP (Specialty Series)	ALL-11	6	R59-T59
9610 OFS (Oil Field Service)	ALL-11	6	R59-T59
9610 ORS (Off Road Service)	ALL-11	6	R59-T59
9610 SP (Specialty Series)	ALL-11	6	R59-T59
9800 OFS (Oil Field Service)	ALL-11	8	R59-T59
9817 OFS (Oil Field Service)	ALL-11	8	R59-T59
9823 OFS (Oil Field Service)	ALL-11	8	R59-T59
9826 OFS (Oil Field Service)	ALL-11	8	R59-T59
9832 OFS (Oil Field Service)	ALL-11	8	R59-T59
9832 OFSD (Oil Field Service)	ALL-11	8	R59-T59
9832 OFSI (Oil Field Service)	ALL-11	8	R59-T59
AT-1542	ALL-4	4	R55
AT-1545	ALL-4	4	R55
AT-540	ALL-4	4	R55
AT-542	ALL-4	4	R55



IMPORTANT: See Safety Information in Section 1 of the Chelsea Applications catalog HY25-3000/US

Transmission PTO Driver & Apertures (Viewed from Rear of Transmission)
L-Left Side R-Right Side B-Bottom Side T-Top Side CS-Countershaft
For transmissions not listed, contact your authorized Chelsea Distributor.

ALLISON TRANSMISSION INDEX

Transmission Make and Model	PTO Appl. Number	Number Forward Speeds	Teeth in PTO Driver
AT-543	ALL-4	4	R55
AT-545	ALL-4	4	R55
B 300	ALL-13	6	L68-R68
B 400	ALL-13	6	L68-R68
B 500	ALL-14	6	L97-T97
CLBT-750	ALL-6	5	L78
CLBT-750 (With Optional 8-Bolt Opening Ahead of Torque Converter)	ALL-12	5	L64-T40
CLBT-754	ALL-6	5	L78
CLBT-754 (With Optional 8-Bolt Opening Ahead of Torque Converter)	ALL-12	5	L64-T40
CLT-750	ALL-6	5	L78
CLT-750 (With Optional 8-Bolt Opening Ahead of Torque Converter)	ALL-12	5	L64-T40
CLT-754	ALL-6	5	L78
CLT-754 (With Optional 8-Bolt Opening Ahead of Torque Converter)	ALL-12	5	L64-T40
H8610 (H = Hauling Mode)	ALL-11	8	R59-T59
HD-4060P (Close Ratio)	ALL-14	6	L97-T97
HD-4070P	ALL-14	7	L97-T97
HD-4560P (Wide Ratio)	ALL-14	6	L97-T97
HT-740CRD	ALL-6	4	L78
HT-740D	ALL-6	4	L78
HT-740DRD	ALL-6	4	L78
HT-740T	ALL-6	4	L78
HT-750CRD	ALL-6	5	L78
HT-750CRD (W/Optional 8-Bolt Opening Ahead of Torque Converter)	ALL-12	5	L64-T40
HT-750D	ALL-6	5	L78
HT-750DP	ALL-6	5	L78
HT-750DRD	ALL-6	5	L78
HT-750DT	ALL-6	5	L78
HT-750HT	ALL-6	5	L78
HT-750T	ALL-6	5	L78
HT-754CR	ALL-6	5	L78
M5600 (M = Mobile Mode)	ALL-8	6	R46-T46
M5610 (M = Mobile Mode)	ALL-8	6	R46-T46
M5620 (M = Mobile Mode)	ALL-8	6	R46-T46
M6510 (M = Mobile Mode)	ALL-8	6	R46-T46
M6520 (M = Mobile Mode)	ALL-8	6	R46-T46
M6600 (M = Mobile Mode)	ALL-8	6	R46-T46

Allison



IMPORTANT: See Safety Information
in Section 1 of the Chelsea Applications
catalog HY25-3000/US

Transmission PTO Driver & Apertures (Viewed from Rear of Transmission)
L-Left Side R-Right Side B-Bottom Side T-Top Side CS-Countershaft
For transmissions not listed, contact your authorized Chelsea Distributor.

Transmission Make and Model	PTO Appl. Number	Number Forward Speeds	Teeth in PTO Driver
M8610 (M = Mobile Mode)	ALL-11	8	R59-T59
M9600 (M = Mobile Mode)	ALL-11	6	R59-T59
M9800 (M = Mobile Mode)	ALL-11	8	R59-T59
MD3050CR-P	ALL-13	5	L68-R68
MD-3060P (Close Ratio)	ALL-13	6	L68-R68
MD-3060PR (Close Ratio)	ALL-13	6	L68-R68
MD-3066P (Europe Only)	ALL-16	6	L83-T83
MD-3070P (Close Ratio)	ALL-18	7	L68-R68
MD-3560P (Wide Ratio)	ALL-13	6	L68-R68
MD-3560PR (Wide Ratio)	ALL-13	6	L68-R68
MT-640	ALL-5	4	R64
MT-643	ALL-5	4	R64
MT-644	ALL-5	4	R64
MT-650	ALL-5	5	R64
MT-653	ALL-5	5	R64
MT-654	ALL-5	5	R64
S5600 (S = Stationary Mode)	ALL-8	6	R46-T46
S5610 (S = Stationary Mode)	ALL-8	6	R46-T46
S5620 (S= Stationary Mode)	ALL-8	6	R46-T46
S6510 (S = Stationary Mode)	ALL-8	6	R46-T46
S6520 (S = Stationary Mode)	ALL-8	6	R46-T46
S6600 (S = Stationary Mode)	ALL-8	6	R46-T46
TC-10	ALL-20	10	CS



IMPORTANT: See Safety Information in Section 1 of the Chelsea Applications catalog HY25-3000/US

Transmission PTO Driver & Apertures (Viewed from Rear of Transmission)
L-Left Side R-Right Side B-Bottom Side T-Top Side CS-Countershaft
For transmissions not listed, contact your authorized Chelsea Distributor.

ALL-4

ALLISON

CHELSEA®

AT-1542
AT-1545
AT-540
AT-542
AT-543
AT-545

RIGHT SIDE ONLY

TRANSMISSION GEAR DATA:
R.S. 06-BOLT Opening Gear FORWARD of Centerline
55 Teeth - SPUR
PITCH LINE TO APERTURE FACE:
1.0850" (27.5600MM)

CAUTION: Application Approval Required for PTO Output Shaft Speeds Above 2500 RPM

PTO Model	Torq	Dir Rot	Engine %		Filler Block	Adapter Assy	Stud Kit	PTO Model	Torq	Dir Rot	Engine %		Filler Block	Adapter Assy	Stud Kit
	I / C †		Fwd	Rev					I / C †		Fwd	Rev			

ONE SPEED - TWO GEAR - MECHANICAL SHIFT

221XCAJP-*3 (8)	235 I	Eng	106	Furnished
221XEAJP-*3 (8)	212 I	Eng	118	Furnished
442XBAHP-*3 (1)	250 I	Eng	90	Furnished

ONE SPEED - TWO GEAR POWERSHIFT (AIR OR HYDRAULIC)

272XAAJP-*3 (2)	300 C	Eng	79	Furnished
272XBAJP-*3 (3)	258 C	Eng	97	Furnished
272XCAJP-*3 (4)	214 C	Eng	117	Furnished
272XDAJP-*3 (5)	179 C	Eng	140	Furnished
272XGAJP-*3 (6)	150 C	Eng	166	Furnished
272XKAJP-*3 (7)	134 C	Eng	186	Furnished

ONE SPEED - POWERSHIFT LOW PROFILE (AIR OR HYDRAULIC)

272MAAJP-*5 (2)	300 C	Eng	79	Furnished
272MBAJP-*5 (3)	258 C	Eng	97	Furnished
272MCAJP-*5 (4)	214 C	Eng	117	Furnished
272MDAJP-*5 (5)	179 C	Eng	140	Furnished
272MGAJP-*5 (6)	150 C	Eng	166	Furnished
272MKAJP-*5 (7)	134 C	Eng	186	Furnished

† I = Intermittent Torque Only - De-rate Torque Rating 30% for Continuous Duty.

C = Continuous or Intermittent Torque - No need to De-Rate Torque Rating.

IMPORTANT: Refer to the back of this transmission section and read all notes associated with this application page. Some notes may affect the proper PTO selection.

CAUTION: PTO output shaft torque ratings are based on the maximum intermittent torque rating of 250 lb-ft torque for the 55 tooth gear in the AT-540 series transmission.

- (1) Input Gear Part No. 5-P-1418
- (2) Input Gear Part No. 5-P-1510-1X
- (3) Input Gear Part No. 5-P-1510-2X
- (4) Input Gear Part No. 5-P-1510-3X
- (5) Input Gear Part No. 5-P-1510-4X
- (6) Input Gear Part No. 5-P-1510-5X
- (7) Input Gear Part No. 5-P-1510-6X
- (8) Input Gear Part No. 5-P-569

Allison

CHELSEA®

ALLISON

ALL-5

MT-640
MT-643
MT-644
MT-650
MT-653
MT-654

RIGHT SIDE ONLY

TRANSMISSION GEAR DATA:

R.S. 06-BOLT Opening Gear FORWARD of Centerline
64 Teeth - SPUR

PITCH LINE TO APERTURE FACE:

1.0850" (27.5600MM)

CAUTION: Application Approval Required for PTO Output Shaft Speeds Above 2500 RPM

PTO Model	Torq	Dir Rot	Engine %		Filler Block	Adapter Assy	Stud Kit	PTO Model	Torq	Dir Rot	Engine %		Filler Block	Adapter Assy	Stud Kit
	I / C †		Fwd	Rev					I / C †		Fwd	Rev			

ONE SPEED - TWO GEAR - MECHANICAL SHIFT

221XCAJP-*3	250 I	Eng	124	Furnished
221XEAJJP-*3	250 I	Eng	137	Furnished
442XBAHP-*5 (1)	250 I	Eng	104	Furnished

ONE SPEED - TWO GEAR POWERSHIFT (AIR OR HYDRAULIC)

272XAAJP-*3 (2)	300 C	Eng	92	Furnished
272XBAJP-*3 (3)	266 C	Eng	113	Furnished
272XCAJP-*3 (4)	220 C	Eng	136	Furnished
272XDAJP-*3 (5)	184 C	Eng	164	Furnished
272XGAJP-*3 (6)	155 C	Eng	194	Furnished

ONE SPEED - POWERSHIFT LOW PROFILE (AIR OR HYDRAULIC)

272MAAJP-*5 (2)	300 C	Eng	92	Furnished
272MBAJP-*5 (3)	266 C	Eng	113	Furnished
272MCAJP-*5 (4)	220 C	Eng	136	Furnished
272MDAJP-*5 (5)	184 C	Eng	164	Furnished
272MGAJP-*5 (6)	155 C	Eng	194	Furnished

† I = Intermittent Torque Only - De-rate Torque Rating 30% for Continuous Duty.

C = Continuous or Intermittent Torque - No need to De-Rate Torque Rating.

IMPORTANT: Refer to the back of this transmission section and read all notes associated with this application page. Some notes may affect the proper PTO selection.

- (1) Input Gear Part No. 5-P-1418
(2) Input Gear Part No. 5-P-1510-1X
(3) Input Gear Part No. 5-P-1510-2X
(4) Input Gear Part No. 5-P-1510-3X
(5) Input Gear Part No. 5-P-1510-4X
(6) Input Gear Part No. 5-P-1510-5X

ALL-6

ALLISON

CHELSEA®

CLBT-750	HT-750D
CLT-750	HT-750DP
CLT-754	HT-750DRD
HT-740CRD	HT-750DT
HT-740D	HT-750HT
HT-740DRD	HT-750T
HT-740T	HT-754CR
HT-750CRD	CLBT-754

LEFT SIDE ONLY**TRANSMISSION GEAR DATA:**L.S. 06-BOLT Opening Gear FORWARD of Centerline
78 Teeth - SPUR**PITCH LINE TO APERTURE FACE:**

1.0850" (27.5600MM)

CAUTION: Application Approval Required for PTO Output Shaft Speeds Above 2500 RPM

PTO Model	Torq	Dir Rot	Engine %		Filler Block	Adapter Assy	Stud Kit	PTO Model	Torq	Dir Rot	Engine %		Filler Block	Adapter Assy	Stud Kit
	I / C †		Fwd	Rev					I / C †		Fwd	Rev			

ONE SPEED - TWO GEAR - MECHANICAL SHIFT

221XCAJP-*5	250 I	Eng	151			Furnished
221XEAJP-*5	250 I	Eng	167			Furnished
442XBAHP-*5 (1)	250 I	Eng	127			Furnished

ONE SPEED - TWO GEAR POWERSHIFT (AIR OR HYDRAULIC)

272XAAJP-*5 (2)	300 C	Eng	112			Furnished
272XBAJP-*5 (3)	300 C	Eng	137			Furnished
272XCAJP-*5 (4)	300 C	Eng	166			Furnished

ONE SPEED - POWERSHIFT LOW PROFILE (AIR OR HYDRAULIC)

272MAAJP-*5 (2)	300 C	Eng	112			Furnished
272MBAJP-*5 (3)	300 C	Eng	137			Furnished
272MCAJP-*5 (4)	300 C	Eng	166			Furnished

† I = Intermittent Torque Only - De-rate Torque Rating 30% for Continuous Duty.

C = Continuous or Intermittent Torque - No need to De-Rate Torque Rating.

IMPORTANT: Refer to the back of this transmission section and read all notes associated with this application page. Some notes may affect the proper PTO selection.

- (1) Input Gear Part No. 5-P-1418
(2) Input Gear Part No. 5-P-1510-1X
(3) Input Gear Part No. 5-P-1510-2X
(4) Input Gear Part No. 5-P-1510-3X

CHELSEA®

ALLISON

ALL-8

5620 OFS	M6600 (M = Mobile Mode)
6620 OFS	S5600 (S = Stationary Mode)
6625 ORS	S5610 (S = Stationary Mode)
M5600 (M = Mobile Mode)	S5620 (S = Stationary Mode)
M5610 (M = Mobile Mode)	S6510 (S = Stationary Mode)
M5620 (M = Mobile Mode)	S6520 (S = Stationary Mode)
M6510 (M = Mobile Mode)	S6600 (S = Stationary Mode)
M6520 (M = Mobile Mode)	

TOP SIDE ONLY

RIGHT SIDE ONLY

TRANSMISSION GEAR DATA:

TOP 08-BOLT Opening Gear REAR of Centerline
46 Teeth - SPUR

PITCH LINE TO APERTURE FACE:

0.8020" (20.3708MM)

TRANSMISSION GEAR DATA:

R.S. 08-BOLT Opening Gear REAR of Centerline
46 Teeth - SPUR

PITCH LINE TO APERTURE FACE:

0.8020" (20.3708MM)

CAUTION: Application Approval Required for PTO Output Shaft Speeds Above 2500 RPM

PTO Model	Torq I / C †	Dir Rot	Engine %		Filler Block	Adapter Assy	Stud Kit	PTO Model	Torq I / C †	Dir Rot	Engine %		Filler Block	Adapter Assy	Stud Kit
			Fwd	Rev							Fwd	Rev			
ONE SPEED - TWO GEAR - MECHANICAL SHIFT															
221ZCAKP-*6	250 I	Opp	89			328564X	Furnished	221ZCAKP-*4	250 I	Eng	89			328564X	Furnished
221ZEAKP-*6	250 I	Opp	99			328564X	Furnished	221ZEAKP-*4	250 I	Eng	99			328564X	Furnished
823XBAKP-*6 (6)	500 I	Opp	81				Furnished	823XBAKP-*4 (6)	500 I	Eng	81				Furnished
823XDAKP-*6 (9)	500 I	Opp	96				Furnished	823XDAKP-*4 (9)	500 I	Eng	96				Furnished
823XGAKP-*6 (10)	500 I	Opp	104				Furnished	823XGAKP-*4 (10)	500 I	Eng	104				Furnished
823XJAKP-*6 (7)	500 I	Opp	122				Furnished	880XBAKP-*4 (1)	500 I	Eng	81				Furnished
823XMAKP-*6 (8)	500 I	Opp	144				Furnished	880XDAKP-*4 (2)	500 I	Eng	96				Furnished
880XBAKP-*6 (1)	500 I	Opp	81				Furnished	880XGAKP-*4 (3)	500 I	Eng	104				Furnished
880XDAKP-*6 (2)	500 I	Opp	96				Furnished								
880XGAKP-*6 (3)	500 I	Opp	104				Furnished								
880XJAKP-*6 (4)	500 I	Opp	122				Furnished								
880XMAKP-*6 (5)	500 I	Opp	144				Furnished								

ONE SPEED - TWO GEAR - POWERSHIFT (AIR)

885XBAKP-*6 (1)	500 I	Opp	81				Furnished	885XBAKP-*4 (1)	500 I	Eng	81				Furnished
885XGAKP-*6 (3)	500 I	Opp	104				Furnished	885XGAKP-*4 (3)	500 I	Eng	104				Furnished
885XJAKP-*6 (4)	500 I	Opp	122				Furnished								
885XMAKP-*6 (5)	500 I	Opp	144				Furnished								

ONE SPEED - TWO GEAR - POWERSHIFT (HYDRAULIC)

852XBAKP-*6	500 I	Opp	81				Furnished	852XBAKP-*4	500 I	Eng	81				Furnished
852XGAKP-*6	500 I	Opp	104				Furnished	852XGAKP-*4	500 I	Eng	104				Furnished
852XJAKP-*6	500 I	Opp	122				Furnished	852XJAKP-*4	500 I	Eng	122				Furnished

† I = Intermittent Torque Only - De-rate Torque Rating 30% for Continuous Duty.

C = Continuous or Intermittent Torque - No need to De-Rate Torque Rating.

IMPORTANT: Refer to the back of this transmission section and read all notes associated with this application page. Some notes may affect the proper PTO selection.

CAUTION: Maximum PTO Continuous torque allowed is 313 lb-ft [424 Nm] due to the transmission manufacturer PTO driver gear limit.

- (1) Input Gear Part No. 5-P-1106
 (2) Input Gear Part No. 5-P-1107
 (3) Input Gear Part No. 5-P-1108
 (4) Input Gear Part No. 5-P-1109
 (5) Input Gear Part No. 5-P-1110
 (6) Input Gear Part No. 5-P-223

- (7) Input Gear Part No. 5-P-224
 (8) Input Gear Part No. 5-P-284
 (9) Input Gear Part No. 5-P-293
 (10) Input Gear Part No. 5-P-294

ALL-11

ALLISON

CHELSEA®

8610 OFS (Oil Field Service) 8610 ORS (Off Road Service) 8610 SP (Specialty Series) 9610 OFS (Oil Field Service) 9610 ORS (Off Road Service) 9610 SP (Specialty Series) 9800 OFS (Oil Field Service) 9817 OFS (Oil Field Service)	9823 OFS (Oil Field Service) 9826 OFS (Oil Field Service) 9832 OFS (Oil Field Service) 9832 OFSD (Oil Field Service) 9832 OFSI (Oil Field Service) H8610 (H = Hauling Mode) M8610 (M = Mobile Mode) M9600 (M = Mobile Mode)	M9800 (M = Mobile Mode)
--	--	-------------------------

TOP SIDE ONLY	RIGHT SIDE ONLY
TRANSMISSION GEAR DATA: TOP 08-BOLT Opening Gear REAR of Centerline 59 Teeth - SPUR PITCH LINE TO APERTURE FACE: 0.8100" (20.5740MM)	TRANSMISSION GEAR DATA: R.S. 08-BOLT Opening Gear REAR of Centerline 59 Teeth - SPUR PITCH LINE TO APERTURE FACE: 0.8100" (20.5740MM)

CAUTION: Application Approval Required for PTO Output Shaft Speeds Above 2500 RPM

PTO Model	Torq		Dir Rot	Engine %		Filler Block	Adapter Assy	Stud Kit	PTO Model	Torq		Dir Rot	Engine %		Filler Block	Adapter Assy	Stud Kit
	I	C †		Fwd	Rev					I	C †		Fwd	Rev			

ONE SPEED - TWO GEAR - MECHANICAL SHIFT

823XBAKP-*6 (6)	500 I	Opp	104					Furnished	823XBAKP-*4 (6)	500 I	Eng	104					Furnished
823XDAKP-*6 (9)	500 I	Opp	123					Furnished	823XDAKP-*4 (9)	500 I	Eng	123					Furnished
823XGAKP-*6 (10)	500 I	Opp	134					Furnished	880XBAKP-*4 (1)	500 I	Eng	104					Furnished
823XJAKP-*6 (7)	500 I	Opp	157					Furnished	880XDAKP-*4 (2)	500 I	Eng	123					Furnished
823XMAKP-*6 (8)	500 I	Opp	185					Furnished	880XGAKP-*4 (3)	500 I	Eng	134					Furnished
880XBAKP-*6 (1)	500 I	Opp	104					Furnished	880XJAKP-*4 (4)	500 I	Eng	157					Furnished
880XDAKP-*6 (2)	500 I	Opp	123					Furnished									
880XGAKP-*6 (3)	500 I	Opp	134					Furnished									
880XJAKP-*6 (4)	500 I	Opp	157					Furnished									
880XMAKP-*6 (5)	500 I	Opp	185					Furnished									

ONE SPEED - TWO GEAR - POWERSHIFT (HYDRAULIC)

852XBAKP-*6	500 I	Opp	104					Furnished	852XBAKP-*4	500 I	Eng	104					Furnished
852XGAKP-*6	500 I	Opp	134					Furnished	852XGAKP-*4	500 I	Eng	134					Furnished
852XJAKP-*6	500 I	Opp	157					Furnished	852XJAKP-*4	500 I	Eng	157					Furnished

† I = Intermittent Torque Only - De-rate Torque Rating 30% for Continuous Duty.

C = Continuous or Intermittent Torque - No need to De-Rate Torque Rating.

IMPORTANT: Refer to the back of this transmission section and read all notes associated with this application page. Some notes may affect the proper PTO selection.

Allison

- (1) Input Gear Part No. 5-P-1106
- (2) Input Gear Part No. 5-P-1107
- (3) Input Gear Part No. 5-P-1108
- (4) Input Gear Part No. 5-P-1109
- (5) Input Gear Part No. 5-P-1110
- (6) Input Gear Part No. 5-P-223

- (7) Input Gear Part No. 5-P-224
- (8) Input Gear Part No. 5-P-284
- (9) Input Gear Part No. 5-P-293
- (10) Input Gear Part No. 5-P-294

CHELSEA®

ALLISON

ALL-12

CLT-750 (With Optional 8-Bolt Opening Ahead of Torque Converter)
 CLT-754 (With Optional 8-Bolt Opening Ahead of Torque Converter)
 HT-750CRD (W/Optional 8-Bolt Opening Ahead of Torque Converter)
 CLBT-750 (With Optional 8-Bolt Opening Ahead of Torque Converter)
 CLBT-754 (With Optional 8-Bolt Opening Ahead of Torque Converter)

LEFT SIDE ONLY

TOP SIDE ONLY

TRANSMISSION GEAR DATA:

L.S. 08-BOLT Opening Gear REAR of Centerline
 64 Teeth - SPUR

PITCH LINE TO APERTURE FACE:

0.8100" (20.5740MM)

TRANSMISSION GEAR DATA:

TOP 08-BOLT Opening Gear REAR of Centerline
 40 Teeth - SPUR

PITCH LINE TO APERTURE FACE:

0.8100" (20.5740MM)

CAUTION: Application Approval Required for PTO Output Shaft Speeds Above 2500 RPM

PTO Model	Torq I / C †	Dir Rot	Engine %		Filler Block	Adapter Assy	Stud Kit	PTO Model	Torq I / C †	Dir Rot	Engine %		Filler Block	Adapter Assy	Stud Kit
			Fwd	Rev							Fwd	Rev			
ONE SPEED - TWO GEAR - MECHANICAL SHIFT															
221ZCAKX-*6	250 I	Opp	104			328564X	Furnished	221ZCAKP-*4	250 I	Opp	104			328564X	Furnished
221ZEAKX-*6	250 I	Opp	116			328564X	Furnished	221ZEAKP-*4	250 I	Opp	116			328564X	Furnished
823XBAKX-*6 (6)	500 I	Opp	95				Furnished	823XBAKP-*4 (6)	500 I	Opp	95				Furnished
823XDAKX-*6 (9)	500 I	Opp	113				Furnished	823XDAKP-*4 (9)	500 I	Opp	113				Furnished
823XGAKX-*6 (10)	500 I	Opp	122				Furnished	823XGAKP-*4 (10)	500 I	Opp	122				Furnished
823XJAKX-*6 (7)	500 I	Opp	144				Furnished	823XJAKP-*4 (7)	500 I	Opp	144				Furnished
823XMAKX-*6 (8)	500 I	Opp	169				Furnished	823XMAKP-*4 (8)	500 I	Opp	169				Furnished
880XBAKX-*6 (1)	500 I	Opp	95				Furnished	880XBAKP-*4 (1)	500 I	Opp	95				Furnished
880XDAKX-*6 (2)	500 I	Opp	113				Furnished	880XDAKP-*4 (2)	500 I	Opp	113				Furnished
880XGAKX-*6 (3)	500 I	Opp	122				Furnished	880XGAKP-*4 (3)	500 I	Opp	122				Furnished
880XJAKX-*6 (4)	500 I	Opp	144				Furnished	880XJAKP-*4 (4)	500 I	Opp	144				Furnished
880XMAKX-*6 (5)	500 I	Opp	169				Furnished	880XMAKP-*4 (5)	500 I	Opp	169				Furnished

ONE SPEED - TWO GEAR - POWERSHIFT (AIR)

885XBAKX-*6 (1)	500 I	Opp	95				Furnished	885XBAKP-*4 (1)	500 I	Opp	95				Furnished
885XGAKX-*6 (3)	500 I	Opp	122				Furnished	885XGAKP-*4 (3)	500 I	Opp	122				Furnished
885XJAKX-*6 (4)	500 I	Opp	144				Furnished	885XJAKP-*4 (4)	500 I	Opp	144				Furnished
885XMAKX-*6 (5)	500 I	Opp	169				Furnished	885XMAKP-*4 (5)	500 I	Opp	169				Furnished

ONE SPEED - TWO GEAR - POWERSHIFT (HYDRAULIC)

852XBAKP-*6	500 I	Opp	95				Furnished	852XBAKP-*4	500 I	Opp	95				Furnished
852XGAKP-*6	500 I	Opp	122				Furnished	852XGAKP-*4	500 I	Opp	122				Furnished
852XJAKP-*6	500 I	Opp	144				Furnished	852XJAKP-*4	500 I	Opp	144				Furnished

ONE SPEED - FORWARD & REVERSE

863XBAKX-*4	500 I	Opp	95	118				Furnished							
-------------	-------	-----	----	-----	--	--	--	-----------	--	--	--	--	--	--	--

† I = Intermittent Torque Only - De-rate Torque Rating 30% for Continuous Duty.

C = Continuous or Intermittent Torque - No need to De-Rate Torque Rating.

IMPORTANT: Refer to the back of this transmission section and read all notes associated with this application page.
 Some notes may affect the proper PTO selection.

(1) Input Gear Part No. 5-P-1106
 (2) Input Gear Part No. 5-P-1107
 (3) Input Gear Part No. 5-P-1108
 (4) Input Gear Part No. 5-P-1109
 (5) Input Gear Part No. 5-P-1110
 (6) Input Gear Part No. 5-P-223

(7) Input Gear Part No. 5-P-224
 (8) Input Gear Part No. 5-P-284
 (9) Input Gear Part No. 5-P-293
 (10) Input Gear Part No. 5-P-294

ALL-13

ALLISON

CHELSEA®

3000 (International - Side/Side PTO Provision)	3200 ORS (Side/Side PTO Provision)	3500 RDS
3000 EVS (Side/Side Power Take-Off Provisions)	3200 SP (Side/Side PTO Provision)	3500 SP (Side/Side PTO Provision)
3000 MH	3200 TRV	B 300
3000 ORS (Side/Side Power Take Off - Provisions)	3414	B 400
3000 RDS	3500 (International - Side/Side PTO Provision)	MD-3060P (Close Ratio)
3000 SP (Side/Side PTO Option)	3500 EVS (Side/Side Power Take-Off Provisions)	MD-3560P (Wide Ratio)
3000 TRV	3500 OFS	MD3050CR-P
3200 (International - Side/Side PTO Provision)	3500 ORS (Side/Side PTO Provision)	

LEFT SIDE ONLY	RIGHT SIDE ONLY
TRANSMISSION GEAR DATA: L.S. 10-BOLT Opening Gear FORWARD of Centerline 68 Teeth - L.H. HELIX PITCH LINE TO APERTURE FACE: 1.7800" (45.2100MM)	TRANSMISSION GEAR DATA: R.S. 10-BOLT Opening Gear FORWARD of Centerline 68 Teeth - L.H. HELIX PITCH LINE TO APERTURE FACE: 1.7800" (45.2100MM)

CAUTION: Application Approval Required for PTO Output Shaft Speeds Above 2500 RPM

PTO Model	Torq I / C †	Dir Rot	Engine %		Filler Block	Adapter Assy	Stud Kit	PTO Model	Torq I / C †	Dir Rot	Engine %		Filler Block	Adapter Assy	Stud Kit
			Fwd	Rev							Fwd	Rev			

ONE SPEED - TWO GEAR - CONSTANT MESH

267SBFJP-5 (4)	402 I	Eng	72			Furnished	267SBFJP-3 (4)	402 I	Eng	72					Furnished
267SDFJP-5 (3)	390 I	Eng	87			Furnished	267SDFJP-3 (3)	390 I	Eng	87					Furnished
267SGFJP-5 (2)	360 I	Eng	103			Furnished	267SGFJP-3 (2)	360 I	Eng	103					Furnished
267SMFJP-5 (5)	318 I	Eng	129			Furnished	267SMFJP-3 (5)	318 I	Eng	129					Furnished
267SSFJP-5 (1)	265 I	Eng	161			Furnished	267SSFJP-3 (1)	265 I	Eng	161					Furnished
267XBFJP-5 (26)	335 I	Eng	72			Furnished	267XBFJP-3 (26)	335 I	Eng	72					Furnished
267XDFJP-5 (27)	325 I	Eng	87			Furnished	267XDFJP-3 (27)	325 I	Eng	87					Furnished
267XGFJP-5 (28)	300 I	Eng	103			Furnished	267XGFJP-3 (28)	300 I	Eng	103					Furnished
267XMFJP-5 (29)	265 I	Eng	129			Furnished	267XMFJP-3 (29)	265 I	Eng	129					Furnished
267XSFJP-5 (1)	250 I	Eng	161			Furnished	267XSFJP-3 (1)	250 I	Eng	161					Furnished
287GBFJP-5 (17)	300 C	Eng	60			Furnished	287GBFJP-3 (17)	300 C	Eng	60					Furnished
287GBFJP-8 (17)	300 C	Eng	56			Furnished	287GBFJP-8 (17)	300 C	Eng	56					Furnished
287GCFJP-5 (18)	390 C	Eng	72			Furnished	287GCFJP-3 (18)	390 C	Eng	72					Furnished
287GCFJP-8 (18)	390 C	Eng	68			Furnished	287GCFJP-8 (18)	390 C	Eng	68					Furnished
287GDFJP-5 (19)	390 C	Eng	87			Furnished	287GDFJP-3 (19)	390 C	Eng	87					Furnished
287GDFJP-8 (19)	390 C	Eng	81			Furnished	287GDFJP-8 (19)	390 C	Eng	81					Furnished
287GGFJP-5 (20)	360 C	Eng	103			Furnished	287GGFJP-3 (20)	360 C	Eng	103					Furnished
287GGFJP-8 (20)	360 C	Eng	96			Furnished	287GGFJP-8 (20)	360 C	Eng	96					Furnished
287GKFJP-5 (21)	340 C	Eng	115			Furnished	287GKFJP-3 (21)	340 C	Eng	115					Furnished
287GMFJP-5 (22)	318 C	Eng	129			Furnished	287GMFJP-3 (22)	318 C	Eng	129					Furnished
287GMFJP-8 (22)	318 C	Eng	119			Furnished	287GMFJP-8 (22)	318 C	Eng	119					Furnished
287GPFJP-5 (23)	290 C	Eng	144			Furnished	287GPFJP-3 (23)	290 C	Eng	144					Furnished
287GPFJP-8 (23)	290 C	Eng	132			Furnished	287GPFJP-8 (23)	290 C	Eng	132					Furnished
287GSFJP-5 (24)	265 C	Eng	161			Furnished	287GSFJP-3 (24)	265 C	Eng	161					Furnished
287GSFJP-8 (24)	265 C	Eng	147			Furnished	287GSFJP-8 (24)	265 C	Eng	147					Furnished
287GTFJP-5 (25)	240 C	Eng	180			Furnished	287GTFJP-3 (25)	240 C	Eng	180					Furnished
287GTFJP-8 (16)	240 C	Eng	173			Furnished	287GTFJP-8 (16)	240 C	Eng	173					Furnished
877XAFJP-5 (7)	591 C	Eng	82			Furnished	877XAFJP-3 (7)	591 C	Eng	82					Furnished
877XBFJP-5 (8)	557 C	Eng	87			Furnished	877XBFJP-3 (8)	557 C	Eng	87					Furnished
877XCFJP-5 (9)	522 C	Eng	93			Furnished	877XCFJP-3 (9)	522 C	Eng	93					Furnished
877XDFJP-5 (10)	490 C	Eng	99			Furnished	877XDFJP-3 (10)	490 C	Eng	99					Furnished
877XEFJP-5 (11)	429 C	Eng	113			Furnished	877XEFJP-3 (11)	429 C	Eng	113					Furnished

Continued on Next Page

† I = Intermittent Torque Only - De-rate Torque Rating 30% for Continuous Duty. C = Continuous or Intermittent Torque - No need to De-Rate Torque Rating.

IMPORTANT: Refer to the back of this transmission section and read all notes associated with this application page. Some notes may affect the proper PTO selection.

CAUTION: Chelsea Recommends the Power Take-Off (PTO) installation on the 3000/4000 Series Transmissions to utilize a Vehicle Interface Module, or Chassis Manufacturer's equivalent controller to incorporate all the PTO control features available, this includes the "PTO Request" and "PTO Enable Output" feature. The "PTO Enable" circuit signals the Transmission Control Module (TCM) to maintain line pressure to the PTO. Failure to provide this signal may not be sufficient to the PTO. This may cause damage to the PTO and /or Transmission. Please see the Allison Transmission website and individual chassis manufacturer for installation details.

- | | | | |
|--------------------------------------|---------------------------------------|--------------------------------------|--------------------------------------|
| 1) Input Gear Part No. 5-P-1173 | (8) Input Gear Part No. 5-P-1428-12X | (18) Input Gear Part No. 5-P-1491-2X | (24) Input Gear Part No. 5-P-1491-8X |
| (2) Input Gear Part No. 5-P-1225 | (9) Input Gear Part No. 5-P-1428-3X | (19) Input Gear Part No. 5-P-1491-3X | (25) Input Gear Part No. 5-P-1491-9X |
| (3) Input Gear Part No. 5-P-1293 | (10) Input Gear Part No. 5-P-1428-4X | (20) Input Gear Part No. 5-P-1491-4X | (26) Input Gear Part No. 5-P-912 |
| (4) Input Gear Part No. 5-P-1350 | (11) Input Gear Part No. 5-P-1428-5X | (21) Input Gear Part No. 5-P-1491-5X | (27) Input Gear Part No. 5-P-913 |
| (5) Input Gear Part No. 5-P-1351 | (16) Input Gear Part No. 5-P-1491-10X | (22) Input Gear Part No. 5-P-1491-6X | (28) Input Gear Part No. 5-P-914 |
| (7) Input Gear Part No. 5-P-1428-11X | (17) Input Gear Part No. 5-P-1491-1X | (23) Input Gear Part No. 5-P-1491-7X | (29) Input Gear Part No. 5-P-915 |

CHELSEA®

ALLISON

ALL-13

3000 (International - Side/Side PTO Provision)	3200 ORS (Side/Side PTO Provision)	3500 SP (Side/Side PTO Provision)
3000 EVS (Side/Side Power Take-Off Provisions)	3200 SP (Side/Side PTO Provision)	B 300
3000 MH	3200 TRV	B 400
3000 ORS (Side/Side Power Take Off - Provisions)	3500 (International - Side/Side PTO Provision)	MD-3060P (Close Ratio)
3000 RDS	3500 EVS (Side/Side Power Take-Off Provisions)	MD-3560P (Wide Ratio)
3000 SP (Side/Side PTO Option)	3500 OFS	MD3050CR-P
3000 TRV	3500 ORS (Side/Side PTO Provision)	
3200 (International - Side/Side PTO Provision)	3500 RDS	

LEFT SIDE ONLY

RIGHT SIDE ONLY

TRANSMISSION GEAR DATA:

L.S. 10-BOLT Opening Gear FORWARD of Centerline
68 Teeth - L.H. HELIX

PITCH LINE TO APERTURE FACE:

1.7800" (45.2100MM)

TRANSMISSION GEAR DATA:

R.S. 10-BOLT Opening Gear FORWARD of Centerline
68 Teeth - L.H. HELIX

PITCH LINE TO APERTURE FACE:

1.7800" (45.2100MM)

CAUTION: Application Approval Required for PTO Output Shaft Speeds Above 2500 RPM

PTO Model	Torq I / C †	Dir Rot	Engine %		Filler Block	Adapter Assy	Stud Kit	PTO Model	Torq I / C †	Dir Rot	Engine %		Filler Block	Adapter Assy	Stud Kit
			Fwd	Rev							Fwd	Rev			

ONE SPEED - TWO GEAR - CONSTANT MESH

877XFFJP-5 (12)	379 C	Eng	128				Furnished	877XFFJP-3 (12)	379 C	Eng	128				Furnished
877XGFP-5 (13)	334 C	Eng	145				Furnished	877XGFP-3 (13)	334 C	Eng	145				Furnished
877XHFJP-5 (14)	315 C	Eng	154				Furnished	877XHFJP-3 (14)	315 C	Eng	154				Furnished
877XJFP-5 (15)	295 C	Eng	164				Furnished	877XJFP-3 (15)	295 C	Eng	164				Furnished
877XKFP-5 (6)	357 C	Eng	136				Furnished	877XKFP-3 (6)	357 C	Eng	136				Furnished

ONE SPEED - TWO GEAR - POWERSHIFT (HYDRAULIC)

280GBFJP-5 (17)	300 C	Eng	60				Furnished	280GBFJP-3 (17)	300 C	Eng	60				Furnished
280GBFJP-8 (17)	300 C	Eng	56				Furnished	280GBFJP-3 (17)	300 C	Eng	56				Furnished
280GCFJP-5 (18)	390 C	Eng	72				Furnished	280GCFJP-3 (18)	390 C	Eng	72				Furnished
280GCFJP-8 (18)	390 C	Eng	68				Furnished	280GCFJP-3 (18)	390 C	Eng	68				Furnished
280GDFJP-5 (19)	390 C	Eng	87				Furnished	280GDFJP-3 (19)	390 C	Eng	87				Furnished
280GDFJP-8 (19)	390 C	Eng	81				Furnished	280GDFJP-3 (19)	390 C	Eng	81				Furnished
280GGFJP-5 (20)	360 C	Eng	103				Furnished	280GGFJP-3 (20)	360 C	Eng	103				Furnished
280GGFJP-8 (20)	360 C	Eng	96				Furnished	280GGFJP-3 (20)	360 C	Eng	96				Furnished
280GKFP-5 (21)	340 C	Eng	115				Furnished	280GKFP-3 (21)	340 C	Eng	115				Furnished
280GMFP-5 (22)	318 C	Eng	129				Furnished	280GMFP-3 (22)	318 C	Eng	129				Furnished
280GMFP-8 (22)	318 C	Eng	119				Furnished	280GMFP-3 (22)	318 C	Eng	119				Furnished
280GPFJP-5 (23)	290 C	Eng	144				Furnished	280GPFJP-3 (23)	290 C	Eng	144				Furnished
280GPFJP-8 (23)	290 C	Eng	132				Furnished	280GPFJP-3 (23)	290 C	Eng	132				Furnished
280GSFJP-5 (24)	265 C	Eng	161				Furnished	280GSFJP-3 (24)	265 C	Eng	161				Furnished
280GSFJP-8 (24)	265 C	Eng	147				Furnished	280GSFJP-3 (24)	265 C	Eng	147				Furnished
280GTFJP-5 (25)	240 C	Eng	180				Furnished	280GTFJP-3 (25)	240 C	Eng	180				Furnished
280GTFJP-8 (16)	240 C	Eng	173				Furnished	280GTFJP-3 (25)	240 C	Eng	173				Furnished
870XAFJP-5 (7)	591 C	Eng	82				Furnished	870XAFJP-3 (7)	591 C	Eng	82				Furnished
870XBFJP-5 (8)	557 C	Eng	87				Furnished	870XBFJP-3 (8)	557 C	Eng	87				Furnished
870XCFJP-5 (9)	522 C	Eng	93				Furnished	870XCFJP-3 (9)	522 C	Eng	93				Furnished
870XDFJP-5 (10)	490 C	Eng	99				Furnished	870XDFJP-3 (10)	490 C	Eng	99				Furnished
870XEFJP-5 (11)	429 C	Eng	113				Furnished	870XEFJP-3 (11)	429 C	Eng	113				Furnished
870XFFJP-5 (12)	379 C	Eng	128				Furnished	870XFFJP-3 (12)	379 C	Eng	128				Furnished
870XGFP-5 (13)	334 C	Eng	145				Furnished	870XGFP-3 (13)	334 C	Eng	145				Furnished

Continued on Next Page

† I = Intermittent Torque Only - De-rate Torque Rating 30% for Continuous Duty.

C = Continuous or Intermittent Torque - No need to De-Rate Torque Rating.

IMPORTANT: Refer to the back of this transmission section and read all notes associated with this application page. Some notes may affect the proper PTO selection.

CAUTION: Chelsea Recommends the Power Take-Off (PTO) installation on the 3000/4000 Series Transmissions to utilize a Vehicle Interface Module, or Chassis Manufacturer's equivalent controller to incorporate all the PTO control features available, this includes the "PTO Request" and "PTO Enable Output" feature. The "PTO Enable" circuit signals the Transmission Control Module (TCM) to maintain line pressure to the PTO. Failure to provide this signal may not be sufficient to the PTO. This may cause damage to the PTO and /or Transmission. Please see the Allison Transmission website and individual chassis manufacturer for installation details.

(6) Input Gear Part No. 5-P-1428-10X
(7) Input Gear Part No. 5-P-1428-11X
(8) Input Gear Part No. 5-P-1428-12X
(9) Input Gear Part No. 5-P-1428-3X
(10) Input Gear Part No. 5-P-1428-4X
(11) Input Gear Part No. 5-P-1428-5X

(12) Input Gear Part No. 5-P-1428-6X
(13) Input Gear Part No. 5-P-1428-7X
(14) Input Gear Part No. 5-P-1428-8X
(15) Input Gear Part No. 5-P-1428-9X
(16) Input Gear Part No. 5-P-1491-10X
(17) Input Gear Part No. 5-P-1491-1X

(18) Input Gear Part No. 5-P-1491-2X
(19) Input Gear Part No. 5-P-1491-3X
(20) Input Gear Part No. 5-P-1491-4X
(21) Input Gear Part No. 5-P-1491-5X
(22) Input Gear Part No. 5-P-1491-6X
(23) Input Gear Part No. 5-P-1491-7X

(24) Input Gear Part No. 5-P-1491-8X
(25) Input Gear Part No. 5-P-1491-9X

ALL-13

ALLISON

CHELSEA®

3000 (International - Side/Side PTO Provision)	3200 ORS (Side/Side PTO Provision)	3500 SP (Side/Side PTO Provision)
3000 EVS (Side/Side Power Take-Off Provisions)	3200 SP (Side/Side PTO Provision)	B 300
3000 MH	3200 TRV	B 400
3000 ORS (Side/Side Power Take Off - Provisions)	3500 (International - Side/Side PTO Provision)	MD-3060P (Close Ratio)
3000 RDS	3500 EVS (Side/Side Power Take-Off Provisions)	MD-3560P (Wide Ratio)
3000 SP (Side/Side PTO Option)	3500 OFS	MD3050CR-P
3000 TRV	3500 ORS (Side/Side PTO Provision)	
3200 (International - Side/Side PTO Provision)	3500 RDS	

LEFT SIDE ONLY

RIGHT SIDE ONLY

<p>TRANSMISSION GEAR DATA: L.S. 10-BOLT Opening Gear FORWARD of Centerline 68 Teeth - L.H. HELIX PITCH LINE TO APERTURE FACE: 1.7800" (45.2100MM)</p>	<p>TRANSMISSION GEAR DATA: R.S. 10-BOLT Opening Gear FORWARD of Centerline 68 Teeth - L.H. HELIX PITCH LINE TO APERTURE FACE: 1.7800" (45.2100MM)</p>
---	---

CAUTION: Application Approval Required for PTO Output Shaft Speeds Above 2500 RPM

PTO Model	Torq I / C †	Dir Rot	Engine %		Filler Block	Adapter Assy	Stud Kit	PTO Model	Torq I / C †	Dir Rot	Engine %		Filler Block	Adapter Assy	Stud Kit
			Fwd	Rev							Fwd	Rev			

ONE SPEED - TWO GEAR - POWERSHIFT (HYDRAULIC)

870XHFJP-*5 (14)	315 C	Eng	154			Furnished	870XHFJP-*3 (14)	315 C	Eng	154					Furnished
870XJFJP-*5 (15)	295 C	Eng	164				870XJFJP-*3 (15)	295 C	Eng	164					Furnished

ONE SPEED - POWERSHIFT (HYDRAULIC) EXTENDED SHAFT

870LAFJW-*5 (7)	591 C	Eng	82			Furnished	870LAFJW-*3 (7)	591 C	Eng	82					Furnished
870LBFJW-*5 (8)	557 C	Eng	87			Furnished	870LBFJW-*3 (8)	557 C	Eng	87					Furnished
870LCFJW-*5 (9)	522 C	Eng	93			Furnished	870LCFJW-*3 (9)	522 C	Eng	93					Furnished
870LDFJW-*5 (10)	490 C	Eng	99			Furnished	870LDFJW-*3 (10)	490 C	Eng	99					Furnished
870LEFJW-*5 (11)	429 C	Eng	113			Furnished	870LEFJW-*3 (11)	429 C	Eng	113					Furnished
870LFFJW-*5 (12)	379 C	Eng	128			Furnished	870LFFJW-*3 (12)	379 C	Eng	128					Furnished
870LGFJW-*5 (13)	334 C	Eng	145			Furnished	870LGFJW-*3 (13)	334 C	Eng	145					Furnished
870LHFJW-*5 (14)	315 C	Eng	154			Furnished	870LHFJW-*3 (14)	315 C	Eng	154					Furnished
890LAFJW-*5 (7)	591 C	Eng	82			Furnished	890RAFJW-*5 (7)	591 C	Eng	82					Furnished
890LBFJW-*5 (8)	557 C	Eng	87			Furnished	890RBFJW-*5 (8)	557 C	Eng	87					Furnished
890LCFJW-*5 (9)	522 C	Eng	93			Furnished	890RCFJW-*5 (9)	522 C	Eng	93					Furnished
890LDFJW-*5 (10)	490 C	Eng	99			Furnished	890RDFJW-*5 (10)	490 C	Eng	99					Furnished
890LEFJW-*5 (11)	429 C	Eng	113			Furnished	890REFJW-*5 (11)	429 C	Eng	113					Furnished
890LFFJW-*5 (12)	379 C	Eng	128			Furnished	890RFFJW-*5 (12)	379 C	Eng	128					Furnished
890LGFJW-*5 (13)	334 C	Eng	145			Furnished	890RGFJW-*5 (13)	334 C	Eng	145					Furnished
890LHFJW-*5 (14)	315 C	Eng	154			Furnished	890RHFJW-*5 (14)	315 C	Eng	154					Furnished

ONE SPEED - CONSTANT MESH EXTENDED SHAFT

877LAFJW-*5 (7)	591 C	Eng	82			Furnished	877LAFJW-*3 (7)	591 C	Eng	82					Furnished
877LBFJW-*5 (8)	557 C	Eng	87			Furnished	877LBFJW-*3 (8)	557 C	Eng	87					Furnished
877LCFJW-*5 (9)	522 C	Eng	93			Furnished	877LCFJW-*3 (9)	522 C	Eng	93					Furnished
877LDFJW-*5 (10)	490 C	Eng	99			Furnished	877LDFJW-*3 (10)	490 C	Eng	99					Furnished
877LEFJW-*5 (11)	429 C	Eng	113			Furnished	877LEFJW-*3 (11)	429 C	Eng	113					Furnished
877LFFJW-*5 (12)	379 C	Eng	128			Furnished	877LFFJW-*3 (12)	379 C	Eng	128					Furnished
877LGFJW-*5 (13)	334 C	Eng	145			Furnished	877LGFJW-*3 (13)	334 C	Eng	145					Furnished
877LHFJW-*5 (14)	315 C	Eng	154			Furnished	877LHFJW-*3 (14)	315 C	Eng	154					Furnished
897LAFJW-*5 (7)	591 C	Eng	82			Furnished	897RAFJW-*5 (7)	591 C	Eng	82					Furnished
897LBFJW-*5 (8)	557 C	Eng	87			Furnished	897RBFJW-*5 (8)	557 C	Eng	87					Furnished

Continued on Next Page

† I = Intermittent Torque Only - De-rate Torque Rating 30% for Continuous Duty.

C = Continuous or Intermittent Torque - No need to De-Rate Torque Rating.

IMPORTANT: Refer to the back of this transmission section and read all notes associated with this application page. Some notes may affect the proper PTO selection.

CAUTION: Chelsea Recommends the Power Take-Off (PTO) installation on the 3000/4000 Series Transmissions to utilize a Vehicle Interface Module, or Chassis Manufacturer's equivalent controller to incorporate all the PTO control features available, this includes the "PTO Request" and "PTO Enable Output" feature. The "PTO Enable" circuit signals the Transmission Control Module (TCM) to maintain line pressure to the PTO. Failure to provide this signal may not be sufficient to the PTO. This may cause damage to the PTO and /or Transmission. Please see the Allison Transmission website and individual chassis manufacturer for installation details.

- (7) Input Gear Part No. 5-P-1428-11X
- (8) Input Gear Part No. 5-P-1428-12X
- (9) Input Gear Part No. 5-P-1428-3X
- (10) Input Gear Part No. 5-P-1428-4X
- (11) Input Gear Part No. 5-P-1428-5X
- (12) Input Gear Part No. 5-P-1428-6X
- (13) Input Gear Part No. 5-P-1428-7X
- (14) Input Gear Part No. 5-P-1428-8X
- (15) Input Gear Part No. 5-P-1428-9X

Allison

CHELSEA®

ALLISON

ALL-13

3000 (International - Side/Side PTO Provision)	3200 ORS (Side/Side PTO Provision)	3500 SP (Side/Side PTO Provision)
3000 EVS (Side/Side Power Take-Off Provisions)	3200 SP (Side/Side PTO Provision)	B 300
3000 MH	3200 TRV	B 400
3000 ORS (Side/Side Power Take Off - Provisions)	3500 (International - Side/Side PTO Provision)	MD-3060P (Close Ratio)
3000 RDS	3500 EVS (Side/Side Power Take-Off Provisions)	MD-3560P (Wide Ratio)
3000 SP (Side/Side PTO Option)	3500 OFS	MD3050CR-P
3000 TRV	3500 ORS (Side/Side PTO Provision)	
3200 (International - Side/Side PTO Provision)	3500 RDS	

LEFT SIDE ONLY

RIGHT SIDE ONLY

TRANSMISSION GEAR DATA:

L.S. 10-BOLT Opening Gear FORWARD of Centerline
68 Teeth - L.H. HELIX

PITCH LINE TO APERTURE FACE:

1.7800" (45.2100MM)

TRANSMISSION GEAR DATA:

R.S. 10-BOLT Opening Gear FORWARD of Centerline
68 Teeth - L.H. HELIX

PITCH LINE TO APERTURE FACE:

1.7800" (45.2100MM)

CAUTION: Application Approval Required for PTO Output Shaft Speeds Above 2500 RPM

PTO Model	Torq I / C †	Dir Rot	Engine %		Filler Block	Adapter Assy	Stud Kit	PTO Model	Torq I / C †	Dir Rot	Engine %		Filler Block	Adapter Assy	Stud Kit
			Fwd	Rev							Fwd	Rev			

ONE SPEED - CONSTANT MESH EXTENDED SHAFT

897LCFJW-*5 (9)	522 C	Eng	93				Furnished	897RCFJW-*5 (9)	522 C	Eng	93				Furnished
897LDFJW-*5 (10)	490 C	Eng	99				Furnished	897RDFJW-*5 (10)	490 C	Eng	99				Furnished
897LEFJW-*5 (11)	429 C	Eng	113				Furnished	897REFJW-*5 (11)	429 C	Eng	113				Furnished
897LFFJW-*5 (12)	379 C	Eng	128				Furnished	897RFFJW-*5 (12)	379 C	Eng	128				Furnished
897LGFJW-*5 (13)	334 C	Eng	145				Furnished	897RGFJW-*5 (13)	334 C	Eng	145				Furnished
897LHFJW-*5 (14)	315 C	Eng	154				Furnished	897RHFJW-*5 (14)	315 C	Eng	154				Furnished

† I = Intermittent Torque Only - De-rate Torque Rating 30% for Continuous Duty.

C = Continuous or Intermittent Torque - No need to De-Rate Torque Rating.

IMPORTANT: Refer to the back of this transmission section and read all notes associated with this application page. Some notes may affect the proper PTO selection.

CAUTION: Chelsea Recommends the Power Take-Off (PTO) installation on the 3000/4000 Series Transmissions to utilize a Vehicle Interface Module, or Chassis Manufacturer's equivalent controller to incorporate all the PTO control features available, this includes the "PTO Request" and "PTO Enable Output" feature. The "PTO Enable" circuit signals the Transmission Control Module (TCM) to maintain line pressure to the PTO. Failure to provide this signal may not be sufficient to the PTO. This may cause damage to the PTO and /or Transmission. Please see the Allison Transmission website and individual chassis manufacturer for installation details.

(9) Input Gear Part No. 5-P-1428-3X
 (10) Input Gear Part No. 5-P-1428-4X
 (11) Input Gear Part No. 5-P-1428-5X
 (12) Input Gear Part No. 5-P-1428-6X
 (13) Input Gear Part No. 5-P-1428-7X
 (14) Input Gear Part No. 5-P-1428-8X

ALL-13C

ALLISON

CHELSEA®

3000 (3000 Family-Side / Side PTO Provision w/ Integral Cooler)

LEFT SIDE ONLY

RIGHT SIDE ONLY

TRANSMISSION GEAR DATA:

L.S. 10-BOLT Opening Gear FORWARD of Centerline
68 Teeth - L.H. HELIX

PITCH LINE TO APERTURE FACE:

1.7800" (45.2100MM)

TRANSMISSION GEAR DATA:

R.S. 10-BOLT Opening Gear FORWARD of Centerline
68 Teeth - L.H. HELIX

PITCH LINE TO APERTURE FACE:

1.7800" (45.2100MM)

CAUTION: Application Approval Required for PTO Output Shaft Speeds Above 2500 RPM

PTO Model	Torq l / C †	Dir Rot	Engine %		Filler Block	Adapter Assy	Stud Kit	PTO Model	Torq l / C †	Dir Rot	Engine %		Filler Block	Adapter Assy	Stud Kit
			Fwd	Rev							Fwd	Rev			

ONE SPEED - TWO GEAR - CONSTANT MESH

267SBFJP-5 (4)	402 I	Eng	72				Furnished	267SBFJP-3 (4)	402 I	Eng	72				Furnished
267SDFJP-5 (3)	390 I	Eng	87				Furnished	267SDFJP-3 (3)	390 I	Eng	87				Furnished
267SGFJP-5 (2)	360 I	Eng	103				Furnished	267SGFJP-3 (2)	360 I	Eng	103				Furnished
267SMFJP-5 (5)	318 I	Eng	129				Furnished	267SMFJP-3 (5)	318 I	Eng	129				Furnished
267SSFJP-5 (1)	265 I	Eng	161				Furnished	267SSFJP-3 (1)	265 I	Eng	161				Furnished
267XBFJP-5 (25)	335 I	Eng	72				Furnished	267XBFJP-3 (25)	335 I	Eng	72				Furnished
267XDFJP-5 (26)	325 I	Eng	87				Furnished	267XDFJP-3 (26)	325 I	Eng	87				Furnished
267XGFJP-5 (27)	300 I	Eng	103				Furnished	267XGFJP-3 (27)	300 I	Eng	103				Furnished
267XMFJP-5 (28)	265 I	Eng	129				Furnished	267XMFJP-3 (28)	265 I	Eng	129				Furnished
267XSFJP-5 (1)	250 I	Eng	161				Furnished	267XSFJP-3 (1)	250 I	Eng	161				Furnished
287GBFJP-5 (16)	300 C	Eng	60				Furnished	287GBFJP-3 (16)	300 C	Eng	60				Furnished
287GBFJP-8 (16)	300 C	Eng	56				Furnished	287GBFJP-8 (16)	300 C	Eng	56				Furnished
287GCFJP-5 (17)	390 C	Eng	72				Furnished	287GCFJP-3 (17)	390 C	Eng	72				Furnished
287GCFJP-8 (17)	390 C	Eng	68				Furnished	287GCFJP-8 (17)	390 C	Eng	68				Furnished
287GDFJP-5 (18)	390 C	Eng	87				Furnished	287GDFJP-3 (18)	390 C	Eng	87				Furnished
287GDFJP-8 (18)	390 C	Eng	81				Furnished	287GDFJP-8 (18)	390 C	Eng	81				Furnished
287GGFJP-5 (19)	360 C	Eng	103				Furnished	287GGFJP-3 (19)	360 C	Eng	103				Furnished
287GGFJP-8 (19)	360 C	Eng	96				Furnished	287GGFJP-8 (19)	360 C	Eng	96				Furnished
287GKFJP-5 (20)	340 C	Eng	115				Furnished	287GKFJP-3 (20)	340 C	Eng	115				Furnished
287GMFJP-5 (21)	318 C	Eng	129				Furnished	287GMFJP-3 (21)	318 C	Eng	129				Furnished
287GMFJP-8 (21)	318 C	Eng	119				Furnished	287GMFJP-8 (21)	318 C	Eng	119				Furnished
287GPFJP-5 (22)	290 C	Eng	144				Furnished	287GPFJP-3 (22)	290 C	Eng	144				Furnished
287GPFJP-8 (22)	290 C	Eng	132				Furnished	287GPFJP-8 (22)	290 C	Eng	132				Furnished
287GSFJP-5 (23)	265 C	Eng	161				Furnished	287GSFJP-3 (23)	265 C	Eng	161				Furnished
287GSFJP-8 (23)	265 C	Eng	147				Furnished	287GSFJP-8 (23)	265 C	Eng	147				Furnished
287GTFJP-5 (24)	240 C	Eng	180				Furnished	287GTFJP-3 (24)	240 C	Eng	180				Furnished
287GTFJP-8 (15)	240 C	Eng	173				Furnished	287GTFJP-8 (15)	240 C	Eng	173				Furnished
877XAFJP-5 (6)	591 C	Eng	82				Furnished	877XAFJP-3 (6)	591 C	Eng	82				Furnished
877XBFJP-5 (7)	557 C	Eng	87				Furnished	877XBFJP-3 (7)	557 C	Eng	87				Furnished
877XCFJP-5 (8)	522 C	Eng	93				Furnished	877XCFJP-3 (8)	522 C	Eng	93				Furnished
877XDFJP-5 (9)	490 C	Eng	99				Furnished	877XDFJP-3 (9)	490 C	Eng	99				Furnished
877XEFJP-5 (10)	429 C	Eng	113				Furnished	877XEFJP-3 (10)	429 C	Eng	113				Furnished

Continued on Next Page

† I = Intermittent Torque Only - De-rate Torque Rating 30% for Continuous Duty.

C = Continuous or Intermittent Torque - No need to De-Rate Torque Rating.

IMPORTANT: Refer to the back of this transmission section and read all notes associated with this application page. Some notes may affect the proper PTO selection.

CAUTION: Chelsea Recommends the Power Take-Off (PTO) installation on the 3000/4000 Series Transmissions to utilize a Vehicle Interface Module, or Chassis Manufacturer's equivalent controller to incorporate all the PTO control features available, this includes the "PTO Request" and "PTO Enable Output" feature. The "PTO Enable" circuit signals the Transmission Control Module (TCM) to maintain line pressure to the PTO. Failure to provide this signal may not be sufficient to the PTO. This may cause damage to the PTO and /or Transmission. Please see the Allison Transmission website and individual chassis manufacturer for installation details.

- | | | | |
|--------------------------------------|---------------------------------------|--------------------------------------|--------------------------------------|
| (1) Input Gear Part No. 5-P-1173 | (7) Input Gear Part No. 5-P-1428-12X | (17) Input Gear Part No. 5-P-1491-2X | (23) Input Gear Part No. 5-P-1491-8X |
| (2) Input Gear Part No. 5-P-1225 | (8) Input Gear Part No. 5-P-1428-3X | (18) Input Gear Part No. 5-P-1491-3X | (24) Input Gear Part No. 5-P-1491-9X |
| (3) Input Gear Part No. 5-P-1293 | (9) Input Gear Part No. 5-P-1428-4X | (19) Input Gear Part No. 5-P-1491-4X | (25) Input Gear Part No. 5-P-912 |
| (4) Input Gear Part No. 5-P-1350 | (10) Input Gear Part No. 5-P-1428-5X | (20) Input Gear Part No. 5-P-1491-5X | (26) Input Gear Part No. 5-P-913 |
| (5) Input Gear Part No. 5-P-1351 | (11) Input Gear Part No. 5-P-1491-10X | (21) Input Gear Part No. 5-P-1491-6X | (27) Input Gear Part No. 5-P-914 |
| (6) Input Gear Part No. 5-P-1428-11X | (16) Input Gear Part No. 5-P-1491-1X | (22) Input Gear Part No. 5-P-1491-7X | (28) Input Gear Part No. 5-P-915 |

Allison

CHELSEA®

ALLISON

ALL-13C

3000 (3000 Family-Side / Side PTO Provision w/ Integral Cooler)

LEFT SIDE ONLY

RIGHT SIDE ONLY

TRANSMISSION GEAR DATA:

L.S. 10-BOLT Opening Gear FORWARD of Centerline
68 Teeth - L.H. HELIX

PITCH LINE TO APERTURE FACE:

1.7800" (45.2100MM)

TRANSMISSION GEAR DATA:

R.S. 10-BOLT Opening Gear FORWARD of Centerline
68 Teeth - L.H. HELIX

PITCH LINE TO APERTURE FACE:

1.7800" (45.2100MM)

CAUTION: Application Approval Required for PTO Output Shaft Speeds Above 2500 RPM

PTO Model	Torq I / C †	Dir Rot	Engine %		Filler Block	Adapter Assy	Stud Kit	PTO Model	Torq I / C †	Dir Rot	Engine %		Filler Block	Adapter Assy	Stud Kit
			Fwd	Rev							Fwd	Rev			

ONE SPEED - TWO GEAR - CONSTANT MESH

877XFFJP-5 (11)	379 C	Eng	128				Furnished	877XFFJP-3 (11)	379 C	Eng	128				Furnished
877XGFJP-5 (12)	334 C	Eng	145				Furnished	877XGFJP-3 (12)	334 C	Eng	145				Furnished
877XHFJP-5 (13)	315 C	Eng	154				Furnished	877XHFJP-3 (13)	315 C	Eng	154				Furnished
877XJFJP-5 (14)	295 C	Eng	164				Furnished	877XJFJP-3 (14)	295 C	Eng	164				Furnished

ONE SPEED - TWO GEAR - POWERSHIFT (HYDRAULIC)

280GBFJP-5 (16)	300 C	Eng	60				Furnished	280GBFJP-3 (16)	300 C	Eng	60				Furnished
280GBFJP-8 (16)	300 C	Eng	56				Furnished	280GBFJP-8 (16)	300 C	Eng	56				Furnished
280GCFJP-5 (17)	390 C	Eng	72				Furnished	280GCFJP-3 (17)	390 C	Eng	72				Furnished
280GCFJP-8 (17)	390 C	Eng	68				Furnished	280GCFJP-8 (17)	390 C	Eng	68				Furnished
280GDFJP-5 (18)	390 C	Eng	87				Furnished	280GDFJP-3 (18)	390 C	Eng	87				Furnished
280GDFJP-8 (18)	390 C	Eng	81				Furnished	280GDFJP-8 (18)	390 C	Eng	81				Furnished
280GGFJP-5 (19)	360 C	Eng	103				Furnished	280GGFJP-3 (19)	360 C	Eng	103				Furnished
280GGFJP-8 (19)	360 C	Eng	96				Furnished	280GGFJP-8 (19)	360 C	Eng	96				Furnished
280GKFJP-5 (20)	340 C	Eng	115				Furnished	280GKFJP-3 (20)	340 C	Eng	115				Furnished
280GMFJP-5 (21)	318 C	Eng	129				Furnished	280GMFJP-3 (21)	318 C	Eng	129				Furnished
280GMFJP-8 (21)	318 C	Eng	119				Furnished	280GMFJP-8 (21)	318 C	Eng	119				Furnished
280GPFJP-5 (22)	290 C	Eng	144				Furnished	280GPFJP-3 (22)	290 C	Eng	144				Furnished
280GPFJP-8 (22)	290 C	Eng	132				Furnished	280GPFJP-8 (22)	290 C	Eng	132				Furnished
280GSFJP-5 (23)	265 C	Eng	161				Furnished	280GSFJP-3 (23)	265 C	Eng	161				Furnished
280GSFJP-8 (23)	265 C	Eng	147				Furnished	280GSFJP-8 (23)	265 C	Eng	147				Furnished
280GTFJP-5 (24)	240 C	Eng	180				Furnished	280GTFJP-3 (24)	240 C	Eng	180				Furnished
280GTFJP-8 (15)	240 C	Eng	173				Furnished	280GTFJP-8 (15)	240 C	Eng	173				Furnished
870XAFJP-5 (6)	591 C	Eng	82				Furnished	870XAFJP-3 (6)	591 C	Eng	82				Furnished
870XBFJP-5 (7)	557 C	Eng	87				Furnished	870XBFJP-3 (7)	557 C	Eng	87				Furnished
870XCFJP-5 (8)	522 C	Eng	93				Furnished	870XCFJP-3 (8)	522 C	Eng	93				Furnished
870XDFJP-5 (9)	490 C	Eng	99				Furnished	870XDFJP-3 (9)	490 C	Eng	99				Furnished
870XEFJP-5 (10)	429 C	Eng	113				Furnished	870XEFJP-3 (10)	429 C	Eng	113				Furnished
870XFFJP-5 (11)	379 C	Eng	128				Furnished	870XFFJP-3 (11)	379 C	Eng	128				Furnished
870XGFJP-5 (12)	334 C	Eng	145				Furnished	870XGFJP-3 (12)	334 C	Eng	145				Furnished
870XHFJP-5 (13)	315 C	Eng	154				Furnished	870XHFJP-3 (13)	315 C	Eng	154				Furnished
870XJFJP-5 (14)	295 C	Eng	164				Furnished	870XJFJP-3 (14)	295 C	Eng	164				Furnished

Continued on Next Page

† I = Intermittent Torque Only - De-rate Torque Rating 30% for Continuous Duty.

C = Continuous or Intermittent Torque - No need to De-Rate Torque Rating.

IMPORTANT: Refer to the back of this transmission section and read all notes associated with this application page. Some notes may affect the proper PTO selection.

CAUTION: Chelsea Recommends the Power Take-Off (PTO) installation on the 3000/4000 Series Transmissions to utilize a Vehicle Interface Module, or Chassis Manufacturer's equivalent controller to incorporate all the PTO control features available, this includes the "PTO Request" and "PTO Enable Output" feature. The "PTO Enable" circuit signals the Transmission Control Module (TCM) to maintain line pressure to the PTO. Failure to provide this signal may not be sufficient to the PTO. This may cause damage to the PTO and /or Transmission. Please see the Allison Transmission website and individual chassis manufacturer for installation details.

(6) Input Gear Part No. 5-P-1428-11x
(7) Input Gear Part No. 5-P-1428-12X
(8) Input Gear Part No. 5-P-1428-3X
(9) Input Gear Part No. 5-P-1428-4X
(10) Input Gear Part No. 5-P-1428-5X
(11) Input Gear Part No. 5-P-1428-6X

(12) Input Gear Part No. 5-P-1428-7X
(13) Input Gear Part No. 5-P-1428-8X
(14) Input Gear Part No. 5-P-1428-9X
(15) Input Gear Part No. 5-P-1491-10X
(16) Input Gear Part No. 5-P-1491-1X
(17) Input Gear Part No. 5-P-1491-2X

(18) Input Gear Part No. 5-P-1491-3X
(19) Input Gear Part No. 5-P-1491-4X
(20) Input Gear Part No. 5-P-1491-5X
(21) Input Gear Part No. 5-P-1491-6X
(22) Input Gear Part No. 5-P-1491-7X
(23) Input Gear Part No. 5-P-1491-8X

(24) Input Gear Part No. 5-P-1491-9X

ALL-13C

ALLISON

CHELSEA®

3000 (3000 Family-Side / Side PTO Provision w/ Integral Cooler)

LEFT SIDE ONLY

RIGHT SIDE ONLY

TRANSMISSION GEAR DATA:

L.S. 10-BOLT Opening Gear FORWARD of Centerline
68 Teeth - L.H. HELIX

PITCH LINE TO APERTURE FACE:

1.7800" (45.2100MM)

TRANSMISSION GEAR DATA:

R.S. 10-BOLT Opening Gear FORWARD of Centerline
68 Teeth - L.H. HELIX

PITCH LINE TO APERTURE FACE:

1.7800" (45.2100MM)

CAUTION: Application Approval Required for PTO Output Shaft Speeds Above 2500 RPM

PTO Model	Torq l / C †	Dir Rot	Engine %		Filler Block	Adapter Assy	Stud Kit	PTO Model	Torq l / C †	Dir Rot	Engine %		Filler Block	Adapter Assy	Stud Kit
			Fwd	Rev							Fwd	Rev			

ONE SPEED - POWERSHIFT (HYDRAULIC) EXTENDED SHAFT

870LAFJW-*5 (6)	591 C	Eng	82				Furnished	870LAFJW-*3 (6)	591 C	Eng	82				Furnished
870LBFJW-*5 (7)	557 C	Eng	87				Furnished	870LBFJW-*3 (7)	557 C	Eng	87				Furnished
870LCFJW-*5 (8)	522 C	Eng	93				Furnished	870LCFJW-*3 (8)	522 C	Eng	93				Furnished
870LDFJW-*5 (9)	490 C	Eng	99				Furnished	870LDFJW-*3 (9)	490 C	Eng	99				Furnished
870LEFJW-*5 (10)	429 C	Eng	113				Furnished	870LEFJW-*3 (10)	429 C	Eng	113				Furnished
870LFFJW-*5 (11)	379 C	Eng	128				Furnished	870LFFJW-*3 (11)	379 C	Eng	128				Furnished
870LGFJW-*5 (12)	334 C	Eng	145				Furnished	870LGFJW-*3 (12)	334 C	Eng	145				Furnished
870LHFJW-*5 (13)	315 C	Eng	154				Furnished	870LHFJW-*3 (13)	315 C	Eng	154				Furnished
890NAFJW-*3 (6)	591 C	Eng	82				Furnished	890RAFJW-*5 (6)	591 C	Eng	82				Furnished
890NBFJW-*3 (7)	557 C	Eng	87				Furnished	890RBFJW-*5 (7)	557 C	Eng	87				Furnished
890NCFJW-*3 (8)	522 C	Eng	93				Furnished	890RCFJW-*5 (8)	522 C	Eng	93				Furnished
890NDFJW-*3 (9)	490 C	Eng	99				Furnished	890RDFJW-*5 (9)	490 C	Eng	99				Furnished
890NEFJW-*3 (10)	429 C	Eng	113				Furnished	890REFJW-*5 (10)	429 C	Eng	113				Furnished
890NFFJW-*3 (11)	379 C	Eng	128				Furnished	890RFFJW-*5 (11)	379 C	Eng	128				Furnished
890NGFJW-*3 (12)	334 C	Eng	145				Furnished	890RGFJW-*5 (12)	334 C	Eng	145				Furnished
890NHJW-*3 (13)	315 C	Eng	154				Furnished	890RHFJW-*5 (13)	315 C	Eng	154				Furnished

ONE SPEED - CONSTANT MESH EXTENDED SHAFT

877LAFJW-*5 (6)	591 C	Eng	82				Furnished	877LAFJW-*3 (6)	591 C	Eng	82				Furnished
877LBFJW-*5 (7)	557 C	Eng	87				Furnished	877LBFJW-*3 (7)	557 C	Eng	87				Furnished
877LCFJW-*5 (8)	522 C	Eng	93				Furnished	877LCFJW-*3 (8)	522 C	Eng	93				Furnished
877LDFJW-*5 (9)	490 C	Eng	99				Furnished	877LDFJW-*3 (9)	490 C	Eng	99				Furnished
877LEFJW-*5 (10)	429 C	Eng	113				Furnished	877LEFJW-*3 (10)	429 C	Eng	113				Furnished
877LFFJW-*5 (11)	379 C	Eng	128				Furnished	877LFFJW-*3 (11)	379 C	Eng	128				Furnished
877LGFJW-*5 (12)	334 C	Eng	145				Furnished	877LGFJW-*3 (12)	334 C	Eng	145				Furnished
877LHFJW-*5 (13)	315 C	Eng	154				Furnished	877LHFJW-*3 (13)	315 C	Eng	154				Furnished
897NAFJW-*3 (6)	591 C	Eng	82				Furnished	897RAFJW-*5 (6)	591 C	Eng	82				Furnished
897NBFJW-*3 (7)	557 C	Eng	87				Furnished	897RBFJW-*5 (7)	557 C	Eng	87				Furnished
897NCFJW-*3 (8)	522 C	Eng	93				Furnished	897RCFJW-*5 (8)	522 C	Eng	93				Furnished
897NDFJW-*3 (9)	490 C	Eng	99				Furnished	897RDFJW-*5 (9)	490 C	Eng	99				Furnished
897NEFJW-*3 (10)	429 C	Eng	113				Furnished	897REFJW-*5 (10)	429 C	Eng	113				Furnished
897NFFJW-*3 (11)	379 C	Eng	128				Furnished	897RFFJW-*5 (11)	379 C	Eng	128				Furnished

Continued on Next Page

† I = Intermittent Torque Only - De-rate Torque Rating 30% for Continuous Duty.

C = Continuous or Intermittent Torque - No need to De-Rate Torque Rating.

IMPORTANT: Refer to the back of this transmission section and read all notes associated with this application page. Some notes may affect the proper PTO selection.

CAUTION: Chelsea Recommends the Power Take-Off (PTO) installation on the 3000/4000 Series Transmissions to utilize a Vehicle Interface Module, or Chassis Manufacturer's equivalent controller to incorporate all the PTO control features available, this includes the "PTO Request" and "PTO Enable Output" feature. The "PTO Enable" circuit signals the Transmission Control Module (TCM) to maintain line pressure to the PTO. Failure to provide this signal may not be sufficient to the PTO. This may cause damage to the PTO and /or Transmission. Please see the Allison Transmission website and individual chassis manufacturer for installation details.

- (6) Input Gear Part No. 5-P-1428-11x
- (7) Input Gear Part No. 5-P-1428-12X
- (8) Input Gear Part No. 5-P-1428-3X
- (9) Input Gear Part No. 5-P-1428-4X
- (10) Input Gear Part No. 5-P-1428-5X
- (11) Input Gear Part No. 5-P-1428-6X

- (12) Input Gear Part No. 5-P-1428-7X
- (13) Input Gear Part No. 5-P-1428-8X

CHELSEA®

ALLISON

ALL-13C

3000 (3000 Family-Side / Side PTO Provision w/ Integral Cooler)

LEFT SIDE ONLY

RIGHT SIDE ONLY

TRANSMISSION GEAR DATA:L.S. 10-BOLT Opening Gear FORWARD of Centerline
68 Teeth - L.H. HELIX**PITCH LINE TO APERTURE FACE:**

1.7800" (45.2100MM)

TRANSMISSION GEAR DATA:R.S. 10-BOLT Opening Gear FORWARD of Centerline
68 Teeth - L.H. HELIX**PITCH LINE TO APERTURE FACE:**

1.7800" (45.2100MM)

CAUTION: Application Approval Required for PTO Output Shaft Speeds Above 2500 RPM

PTO Model	Torq	Dir Rot	Engine %		Filler Block	Adapter Assy	Stud Kit	PTO Model	Torq	Dir Rot	Engine %		Filler Block	Adapter Assy	Stud Kit
	I / C †		Fwd	Rev					I / C †		Fwd	Rev			

ONE SPEED - CONSTANT MESH EXTENDED SHAFT

897NGFJW-*3 (12)	334 C	Eng	145				Furnished	897RGFJW-*5 (12)	334 C	Eng	145				Furnished
897NHFJW-*3 (13)	315 C	Eng	154				Furnished	897RHFJW-*5 (13)	315 C	Eng	154				Furnished

† I = Intermittent Torque Only - De-rate Torque Rating 30% for Continuous Duty.

C = Continuous or Intermittent Torque - No need to De-Rate Torque Rating.

IMPORTANT: Refer to the back of this transmission section and read all notes associated with this application page. Some notes may affect the proper PTO selection.

CAUTION: Chelsea Recommends the Power Take-Off (PTO) installation on the 3000/4000 Series Transmissions to utilize a Vehicle Interface Module, or Chassis Manufacturer's equivalent controller to incorporate all the PTO control features available, this includes the "PTO Request" and "PTO Enable Output" feature. The "PTO Enable" circuit signals the Transmission Control Module (TCM) to maintain line pressure to the PTO. Failure to provide this signal may not be sufficient to the PTO. This may cause damage to the PTO and /or Transmission. Please see the Allison Transmission website and individual chassis manufacturer for installation details.

(12) Input Gear Part No. 5-P-1428-7X
(13) Input Gear Part No. 5-P-1428-8X

ALL-13EC

ALLISON

CHELSEA®

3000 (Econic) (3000 Family-Side / Side PTO Provision w/ Integral Cooler
Daimler Econic)

LEFT SIDE ONLY

TRANSMISSION GEAR DATA:

L.S. 10-BOLT Opening Gear FORWARD of Centerline
68 Teeth - L.H. HELIX

PITCH LINE TO APERTURE FACE:

1.7800" (45.2100MM)

CAUTION: Application Approval Required for PTO Output Shaft Speeds Above 2500 RPM

PTO Model	Torq	Dir Rot	Engine %		Filler Block	Adapter Assy	Stud Kit	PTO Model	Torq	Dir Rot	Engine %		Filler Block	Adapter Assy	Stud Kit
	I / C †		Fwd	Rev					I / C †		Fwd	Rev			

ONE SPEED - POWERSHIFT (HYDRAULIC) EXTENDED SHAFT

870LAFJW-*3 (1)	591 C	Eng	82				Furnished
870LBFJW-*3 (2)	557 C	Eng	87				Furnished
870LCFJW-*3 (3)	522 C	Eng	93				Furnished
870LDFJW-*3 (4)	490 C	Eng	99				Furnished
870LEFJW-*3 (5)	429 C	Eng	113				Furnished
870LFFJW-*3 (6)	379 C	Eng	128				Furnished
870LGFJW-*3 (7)	334 C	Eng	145				Furnished
870LHFJW-*3 (8)	315 C	Eng	154				Furnished

ONE SPEED - CONSTANT MESH EXTENDED SHAFT

877LAFJW-*3 (1)	591 C	Eng	82				Furnished
877LBFJW-*3 (2)	557 C	Eng	87				Furnished
877LCFJW-*3 (3)	522 C	Eng	93				Furnished
877LDFJW-*3 (4)	490 C	Eng	99				Furnished
877LEFJW-*3 (5)	429 C	Eng	113				Furnished
877LFFJW-*3 (6)	379 C	Eng	128				Furnished
877LGFJW-*3 (7)	334 C	Eng	145				Furnished
877LHFJW-*3 (8)	315 C	Eng	154				Furnished

† I = Intermittent Torque Only - De-rate Torque Rating 30% for Continuous Duty.

C = Continuous or Intermittent Torque - No need to De-Rate Torque Rating.

IMPORTANT: Refer to the back of this transmission section and read all notes associated with this application page. Some notes may affect the proper PTO selection.

CAUTION: Chelsea Recommends the Power Take-Off (PTO) installation on the 3000/4000 Series Transmissions to utilize a Vehicle Interface Module, or Chassis Manufacturer's equivalent controller to incorporate all the PTO control features available, this includes the "PTO Request" and "PTO Enable Output" feature. The "PTO Enable" circuit signals the Transmission Control Module (TCM) to maintain line pressure to the PTO. Failure to provide this signal may not be sufficient to the PTO. This may cause damage to the PTO and /or Transmission. Please see the Allison Transmission website and individual chassis manufacturer for installation details.

(1) Input Gear Part No. 5-P-1428-11X
 (2) Input Gear Part No. 5-P-1428-12X
 (3) Input Gear Part No. 5-P-1428-3X
 (4) Input Gear Part No. 5-P-1428-4X
 (5) Input Gear Part No. 5-P-1428-5X
 (6) Input Gear Part No. 5-P-1428-6X

(7) Input Gear Part No. 5-P-1428-7X
 (8) Input Gear Part No. 5-P-1428-8X

CHELSEA®

ALLISON

ALL-13R

3000 (3000 Family- Side/Side PTO Provision w/ Retarder)

LEFT SIDE ONLY

RIGHT SIDE ONLY

TRANSMISSION GEAR DATA:

L.S. 10-BOLT Opening Gear FORWARD of Centerline
68 Teeth - L.H. HELIX

PITCH LINE TO APERTURE FACE:

1.7800" (45.2100MM)

TRANSMISSION GEAR DATA:

R.S. 10-BOLT Opening Gear FORWARD of Centerline
68 Teeth - L.H. HELIX

PITCH LINE TO APERTURE FACE:

1.7800" (45.2100MM)

CAUTION: Application Approval Required for PTO Output Shaft Speeds Above 2500 RPM

PTO Model	Torq I / C †	Dir Rot	Engine %		Filler Block	Adapter Assy	Stud Kit	PTO Model	Torq I / C †	Dir Rot	Engine %		Filler Block	Adapter Assy	Stud Kit
			Fwd	Rev							Fwd	Rev			

ONE SPEED - TWO GEAR - CONSTANT MESH

267SBFJP-5 (4)	402 I	Eng	72				Furnished	267SBFJP-3 (4)	402 I	Eng	72				Furnished
267SDFJP-5 (3)	390 I	Eng	87				Furnished	267SDFJP-3 (3)	390 I	Eng	87				Furnished
267SGFJP-5 (2)	360 I	Eng	103				Furnished	267SGFJP-3 (2)	360 I	Eng	103				Furnished
267SMFJP-5 (5)	318 I	Eng	129				Furnished	267SMFJP-3 (5)	318 I	Eng	129				Furnished
267SSFJP-5 (1)	265 I	Eng	161				Furnished	267SSFJP-3 (1)	265 I	Eng	161				Furnished
267XBFJP-5 (25)	335 I	Eng	72				Furnished	267XBFJP-3 (25)	335 I	Eng	72				Furnished
267XDFJP-5 (26)	325 I	Eng	87				Furnished	267XDFJP-3 (26)	325 I	Eng	87				Furnished
267XGFJP-5 (27)	300 I	Eng	103				Furnished	267XGFJP-3 (27)	300 I	Eng	103				Furnished
267XMFJP-5 (28)	265 I	Eng	129				Furnished	267XMFJP-3 (28)	265 I	Eng	129				Furnished
267XSFJP-5 (1)	250 I	Eng	161				Furnished	267XSFJP-3 (1)	250 I	Eng	161				Furnished
287GBFJP-5 (16)	300 C	Eng	60				Furnished	287GBFJP-3 (16)	300 C	Eng	60				Furnished
287GBFJP-8 (16)	300 C	Eng	56				Furnished	287GBFJP-3 (16)	300 C	Eng	56				Furnished
287GCFJP-5 (17)	390 C	Eng	72				Furnished	287GCFJP-3 (17)	390 C	Eng	72				Furnished
287GCFJP-8 (17)	390 C	Eng	68				Furnished	287GCFJP-3 (17)	390 C	Eng	68				Furnished
287GDFJP-5 (18)	390 C	Eng	87				Furnished	287GDFJP-3 (18)	390 C	Eng	87				Furnished
287GDFJP-8 (18)	390 C	Eng	81				Furnished	287GDFJP-3 (18)	390 C	Eng	81				Furnished
287GGFJP-5 (19)	360 C	Eng	103				Furnished	287GGFJP-3 (19)	360 C	Eng	103				Furnished
287GGFJP-8 (19)	360 C	Eng	96				Furnished	287GGFJP-3 (19)	360 C	Eng	96				Furnished
287GKFJP-5 (20)	340 C	Eng	115				Furnished	287GKFJP-3 (20)	340 C	Eng	115				Furnished
287GMFJP-5 (21)	318 C	Eng	129				Furnished	287GMFJP-3 (21)	318 C	Eng	129				Furnished
287GMFJP-8 (21)	318 C	Eng	119				Furnished	287GMFJP-3 (21)	318 C	Eng	119				Furnished
287GPFJP-5 (22)	290 C	Eng	144				Furnished	287GPFJP-3 (22)	290 C	Eng	144				Furnished
287GPFJP-8 (22)	290 C	Eng	132				Furnished	287GPFJP-3 (22)	290 C	Eng	132				Furnished
287GSFJP-5 (23)	265 C	Eng	161				Furnished	287GSFJP-3 (23)	265 C	Eng	161				Furnished
287GSFJP-8 (23)	265 C	Eng	147				Furnished	287GSFJP-3 (23)	265 C	Eng	147				Furnished
287GTFJP-5 (24)	240 C	Eng	180				Furnished	287GTFJP-3 (24)	240 C	Eng	180				Furnished
287GTFJP-8 (15)	240 C	Eng	173				Furnished	287GTFJP-3 (15)	240 C	Eng	173				Furnished
877XAFJP-5 (6)	591 C	Eng	82				Furnished	877XAFJP-3 (6)	591 C	Eng	82				Furnished
877XBFJP-5 (7)	557 C	Eng	87				Furnished	877XBFJP-3 (7)	557 C	Eng	87				Furnished
877XCFJP-5 (8)	522 C	Eng	93				Furnished	877XCFJP-3 (8)	522 C	Eng	93				Furnished
877XDFJP-5 (9)	490 C	Eng	99				Furnished	877XDFJP-3 (9)	490 C	Eng	99				Furnished
877XEFJP-5 (10)	429 C	Eng	113				Furnished	877XEFJP-3 (10)	429 C	Eng	113				Furnished

Continued on Next Page

† I = Intermittent Torque Only - De-rate Torque Rating 30% for Continuous Duty.

C = Continuous or Intermittent Torque - No need to De-Rate Torque Rating.

IMPORTANT: Refer to the back of this transmission section and read all notes associated with this application page. Some notes may affect the proper PTO selection.

CAUTION: Chelsea Recommends the Power Take-Off (PTO) installation on the 3000/4000 Series Transmissions to utilize a Vehicle Interface Module, or Chassis Manufacturer's equivalent controller to incorporate all the PTO control features available, this includes the "PTO Request" and "PTO Enable Output" feature. The "PTO Enable" circuit signals the Transmission Control Module (TCM) to maintain line pressure to the PTO. Failure to provide this signal may not be sufficient to the PTO. This may cause damage to the PTO and /or Transmission. Please see the Allison Transmission website and individual chassis manufacturer for installation details.

(1) Input Gear Part No. 5-P-1173
 (2) Input Gear Part No. 5-P-1225
 (3) Input Gear Part No. 5-P-1293
 (4) Input Gear Part No. 5-P-1350
 (5) Input Gear Part No. 5-P-1351
 (6) Input Gear Part No. 5-P-1428-11X

(7) Input Gear Part No. 5-P-1428-12X
 (8) Input Gear Part No. 5-P-1428-3X
 (9) Input Gear Part No. 5-P-1428-4X
 (10) Input Gear Part No. 5-P-1428-5X
 (15) Input Gear Part No. 5-P-1491-10X
 (16) Input Gear Part No. 5-P-1491-1X

(17) Input Gear Part No. 5-P-1491-2X
 (18) Input Gear Part No. 5-P-1491-3X
 (19) Input Gear Part No. 5-P-1491-4X
 (20) Input Gear Part No. 5-P-1491-5X
 (21) Input Gear Part No. 5-P-1491-6X
 (22) Input Gear Part No. 5-P-1491-7X

(23) Input Gear Part No. 5-P-1491-8X
 (24) Input Gear Part No. 5-P-1491-9X
 (25) Input Gear Part No. 5-P-912
 (26) Input Gear Part No. 5-P-913
 (27) Input Gear Part No. 5-P-914
 (28) Input Gear Part No. 5-P-915

ALL-13R

ALLISON

CHELSEA®

3000 (3000 Family- Side/Side PTO Provision w/ Retarder)

LEFT SIDE ONLY

RIGHT SIDE ONLY

TRANSMISSION GEAR DATA:

L.S. 10-BOLT Opening Gear FORWARD of Centerline
68 Teeth - L.H. HELIX

PITCH LINE TO APERTURE FACE:

1.7800" (45.2100MM)

TRANSMISSION GEAR DATA:

R.S. 10-BOLT Opening Gear FORWARD of Centerline
68 Teeth - L.H. HELIX

PITCH LINE TO APERTURE FACE:

1.7800" (45.2100MM)

CAUTION: Application Approval Required for PTO Output Shaft Speeds Above 2500 RPM

PTO Model	Torq	Dir Rot	Engine %		Filler Block	Adapter Assy	Stud Kit	PTO Model	Torq	Dir Rot	Engine %		Filler Block	Adapter Assy	Stud Kit
	I / C †		Fwd	Rev					I / C †		Fwd	Rev			

ONE SPEED - TWO GEAR - CONSTANT MESH

877XFFJP-*5 (11)	379 C	Eng	128			Furnished	877XFFJP-*3 (11)	379 C	Eng	128					Furnished
877XGFJP-*5 (12)	334 C	Eng	145			Furnished	877XGFJP-*3 (12)	334 C	Eng	145					Furnished
877XHFJP-*5 (13)	315 C	Eng	154			Furnished	877XHFJP-*3 (13)	315 C	Eng	154					Furnished
877XJFJP-*5 (14)	295 C	Eng	164			Furnished	877XJFJP-*3 (14)	295 C	Eng	164					Furnished

ONE SPEED - TWO GEAR - POWERSHIFT (HYDRAULIC)

280GBFJP-*5 (16)	300 C	Eng	60			Furnished	280GBFJP-*3 (16)	300 C	Eng	60					Furnished
280GBFJP-*8 (16)	300 C	Eng	56			Furnished	280GBFJP-*8 (16)	300 C	Eng	56					Furnished
280GCFJP-*5 (17)	390 C	Eng	72			Furnished	280GCFJP-*3 (17)	390 C	Eng	72					Furnished
280GCFJP-*8 (17)	390 C	Eng	68			Furnished	280GCFJP-*8 (17)	390 C	Eng	68					Furnished
280GDFJP-*5 (18)	390 C	Eng	87			Furnished	280GDFJP-*3 (18)	390 C	Eng	87					Furnished
280GDFJP-*8 (18)	390 C	Eng	81			Furnished	280GDFJP-*8 (18)	390 C	Eng	81					Furnished
280GGFJP-*5 (19)	360 C	Eng	103			Furnished	280GGFJP-*3 (19)	360 C	Eng	103					Furnished
280GGFJP-*8 (19)	360 C	Eng	96			Furnished	280GGFJP-*8 (19)	360 C	Eng	96					Furnished
280GKFJP-*5 (20)	340 C	Eng	115			Furnished	280GKFJP-*3 (20)	340 C	Eng	115					Furnished
280GMFJP-*5 (21)	318 C	Eng	129			Furnished	280GMFJP-*3 (21)	318 C	Eng	129					Furnished
280GMFJP-*8 (21)	318 C	Eng	119			Furnished	280GMFJP-*8 (21)	318 C	Eng	119					Furnished
280GPFJP-*5 (22)	290 C	Eng	144			Furnished	280GPFJP-*3 (22)	290 C	Eng	144					Furnished
280GPFJP-*8 (22)	290 C	Eng	132			Furnished	280GPFJP-*8 (22)	290 C	Eng	132					Furnished
280GSFJP-*5 (23)	265 C	Eng	161			Furnished	280GSFJP-*3 (23)	265 C	Eng	161					Furnished
280GSFJP-*8 (23)	265 C	Eng	147			Furnished	280GSFJP-*8 (23)	265 C	Eng	147					Furnished
280GTFJP-*5 (24)	240 C	Eng	180			Furnished	280GTFJP-*3 (24)	240 C	Eng	180					Furnished
280GTFJP-*8 (15)	240 C	Eng	173			Furnished	280GTFJP-*8 (15)	240 C	Eng	173					Furnished
870XAFJP-*5 (6)	591 C	Eng	82			Furnished	870XAFJP-*3 (6)	591 C	Eng	82					Furnished
870XBFJP-*5 (7)	557 C	Eng	87			Furnished	870XBFJP-*3 (7)	557 C	Eng	87					Furnished
870XCFJP-*5 (8)	522 C	Eng	93			Furnished	870XCFJP-*3 (8)	522 C	Eng	93					Furnished
870XDFJP-*5 (9)	490 C	Eng	99			Furnished	870XDFJP-*3 (9)	490 C	Eng	99					Furnished
870XEFJP-*5 (10)	429 C	Eng	113			Furnished	870XEFJP-*3 (10)	429 C	Eng	113					Furnished
870XFFJP-*5 (11)	379 C	Eng	128			Furnished	870XFFJP-*3 (11)	379 C	Eng	128					Furnished
870XGFJP-*5 (12)	334 C	Eng	145			Furnished	870XGFJP-*3 (12)	334 C	Eng	145					Furnished
870XHFJP-*5 (13)	315 C	Eng	154			Furnished	870XHFJP-*3 (13)	315 C	Eng	154					Furnished
870XJFJP-*5 (14)	295 C	Eng	164			Furnished	870XJFJP-*3 (14)	295 C	Eng	164					Furnished

Continued on Next Page

† I = Intermittent Torque Only - De-rate Torque Rating 30% for Continuous Duty.

C = Continuous or Intermittent Torque - No need to De-Rate Torque Rating.

IMPORTANT: Refer to the back of this transmission section and read all notes associated with this application page. Some notes may affect the proper PTO selection.

CAUTION: Chelsea Recommends the Power Take-Off (PTO) installation on the 3000/4000 Series Transmissions to utilize a Vehicle Interface Module, or Chassis Manufacturer's equivalent controller to incorporate all the PTO control features available, this includes the "PTO Request" and "PTO Enable Output" feature. The "PTO Enable" circuit signals the Transmission Control Module (TCM) to maintain line pressure to the PTO. Failure to provide this signal may not be sufficient to the PTO. This may cause damage to the PTO and /or Transmission. Please see the Allison Transmission website and individual chassis manufacturer for installation details.

- (6) Input Gear Part No. 5-P-1428-11X
- (7) Input Gear Part No. 5-P-1428-12X
- (8) Input Gear Part No. 5-P-1428-3X
- (9) Input Gear Part No. 5-P-1428-4X
- (10) Input Gear Part No. 5-P-1428-5X
- (11) Input Gear Part No. 5-P-1428-6X
- (12) Input Gear Part No. 5-P-1428-7X
- (13) Input Gear Part No. 5-P-1428-8X
- (14) Input Gear Part No. 5-P-1428-9X
- (15) Input Gear Part No. 5-P-1491-10X
- (16) Input Gear Part No. 5-P-1491-1X
- (17) Input Gear Part No. 5-P-1491-2X
- (18) Input Gear Part No. 5-P-1491-3X
- (19) Input Gear Part No. 5-P-1491-4X
- (20) Input Gear Part No. 5-P-1491-5X
- (21) Input Gear Part No. 5-P-1491-6X
- (22) Input Gear Part No. 5-P-1491-7X
- (23) Input Gear Part No. 5-P-1491-8X
- (24) Input Gear Part No. 5-P-1491-9X

Allison

CHELSEA®

ALLISON

ALL-13R

3000 (3000 Family- Side/Side PTO Provision w/ Retarder)

LEFT SIDE ONLY

RIGHT SIDE ONLY

TRANSMISSION GEAR DATA:

L.S. 10-BOLT Opening Gear FORWARD of Centerline
68 Teeth - L.H. HELIX

PITCH LINE TO APERTURE FACE:

1.7800" (45.2100MM)

TRANSMISSION GEAR DATA:

R.S. 10-BOLT Opening Gear FORWARD of Centerline
68 Teeth - L.H. HELIX

PITCH LINE TO APERTURE FACE:

1.7800" (45.2100MM)

CAUTION: Application Approval Required for PTO Output Shaft Speeds Above 2500 RPM

PTO Model	Torq I / C †	Dir Rot	Engine %		Filler Block	Adapter Assy	Stud Kit	PTO Model	Torq I / C †	Dir Rot	Engine %		Filler Block	Adapter Assy	Stud Kit
			Fwd	Rev							Fwd	Rev			

ONE SPEED - POWERSHIFT (HYDRAULIC) EXTENDED SHAFT

870LAFJW-*5 (6)	591 C	Eng	82				Furnished	870LAFJW-*3 (6)	591 C	Eng	82				Furnished
870LBFJW-*5 (7)	557 C	Eng	87				Furnished	870LBFJW-*3 (7)	557 C	Eng	87				Furnished
870LCFJW-*5 (8)	522 C	Eng	93				Furnished	870LCFJW-*3 (8)	522 C	Eng	93				Furnished
870LDFJW-*5 (9)	490 C	Eng	99				Furnished	870LDFJW-*3 (9)	490 C	Eng	99				Furnished
870LEFJW-*5 (10)	429 C	Eng	113				Furnished	870LEFJW-*3 (10)	429 C	Eng	113				Furnished
870LFFJW-*5 (11)	379 C	Eng	128				Furnished	870LFFJW-*3 (11)	379 C	Eng	128				Furnished
870LGFJW-*5 (12)	334 C	Eng	145				Furnished	870LGFJW-*3 (12)	334 C	Eng	145				Furnished
870LHFJW-*5 (13)	315 C	Eng	154				Furnished	870LHFJW-*3 (13)	315 C	Eng	154				Furnished
890MAFJW-*5 (6)	591 C	Eng	82				Furnished								
890MBFJW-*5 (7)	557 C	Eng	87				Furnished								
890MCFJW-*5 (8)	522 C	Eng	93				Furnished								
890MDFJW-*5 (9)	490 C	Eng	99				Furnished								
890MEFJW-*5 (10)	429 C	Eng	113				Furnished								
890MFFJW-*5 (11)	379 C	Eng	128				Furnished								
890MGFJW-*5 (12)	334 C	Eng	145				Furnished								
890MHFJW-*5 (13)	315 C	Eng	154				Furnished								

ONE SPEED - CONSTANT MESH EXTENDED SHAFT

877LAFJW-*5 (6)	591 C	Eng	82				Furnished	877LAFJW-*3 (6)	591 C	Eng	82				Furnished
877LBFJW-*5 (7)	557 C	Eng	87				Furnished	877LBFJW-*3 (7)	557 C	Eng	87				Furnished
877LCFJW-*5 (8)	522 C	Eng	93				Furnished	877LCFJW-*3 (8)	522 C	Eng	93				Furnished
877LDFJW-*5 (9)	490 C	Eng	99				Furnished	877LDFJW-*3 (9)	490 C	Eng	99				Furnished
877LEFJW-*5 (10)	429 C	Eng	113				Furnished	877LEFJW-*3 (10)	429 C	Eng	113				Furnished
877LFFJW-*5 (11)	379 C	Eng	128				Furnished	877LFFJW-*3 (11)	379 C	Eng	128				Furnished
877LGFJW-*5 (12)	334 C	Eng	145				Furnished	877LGFJW-*3 (12)	334 C	Eng	145				Furnished
877LHFJW-*5 (13)	315 C	Eng	154				Furnished	877LHFJW-*3 (13)	315 C	Eng	154				Furnished
897MAFJW-*5 (6)	591 C	Eng	82				Furnished								
897MBFJW-*5 (7)	557 C	Eng	87				Furnished								
897MCFJW-*5 (8)	522 C	Eng	93				Furnished								
897MDFJW-*5 (9)	490 C	Eng	99				Furnished								
897MEFJW-*5 (10)	429 C	Eng	113				Furnished								
897MFFJW-*5 (11)	379 C	Eng	128				Furnished								

Continued on Next Page

† I = Intermittent Torque Only - De-rate Torque Rating 30% for Continuous Duty.

C = Continuous or Intermittent Torque - No need to De-Rate Torque Rating.

IMPORTANT: Refer to the back of this transmission section and read all notes associated with this application page. Some notes may affect the proper PTO selection.

CAUTION: Chelsea Recommends the Power Take-Off (PTO) installation on the 3000/4000 Series Transmissions to utilize a Vehicle Interface Module, or Chassis Manufacturer's equivalent controller to incorporate all the PTO control features available, this includes the "PTO Request" and "PTO Enable Output" feature. The "PTO Enable" circuit signals the Transmission Control Module (TCM) to maintain line pressure to the PTO. Failure to provide this signal may not be sufficient to the PTO. This may cause damage to the PTO and /or Transmission. Please see the Allison Transmission website and individual chassis manufacturer for installation details.

(6) Input Gear Part No. 5-P-1428-11X
(7) Input Gear Part No. 5-P-1428-12X
(8) Input Gear Part No. 5-P-1428-3X
(9) Input Gear Part No. 5-P-1428-4X
(10) Input Gear Part No. 5-P-1428-5X
(11) Input Gear Part No. 5-P-1428-6X

(12) Input Gear Part No. 5-P-1428-7X
(13) Input Gear Part No. 5-P-1428-8X

ALL-13R

ALLISON

CHELSEA®

3000 (3000 Family- Side/Side PTO Provision w/ Retarder)

LEFT SIDE ONLY

RIGHT SIDE ONLY

TRANSMISSION GEAR DATA:L.S. 10-BOLT Opening Gear FORWARD of Centerline
68 Teeth - L.H. HELIX**PITCH LINE TO APERTURE FACE:**

1.7800" (45.2100MM)

TRANSMISSION GEAR DATA:R.S. 10-BOLT Opening Gear FORWARD of Centerline
68 Teeth - L.H. HELIX**PITCH LINE TO APERTURE FACE:**

1.7800" (45.2100MM)

CAUTION: Application Approval Required for PTO Output Shaft Speeds Above 2500 RPM

PTO Model	Torq	Dir Rot	Engine %		Filler Block	Adapter Assy	Stud Kit	PTO Model	Torq	Dir Rot	Engine %		Filler Block	Adapter Assy	Stud Kit
	I / C †		Fwd	Rev					I / C †		Fwd	Rev			

ONE SPEED - CONSTANT MESH EXTENDED SHAFT

897MGFJW-*5 (12)	334 C	Eng	145												Furnished
897MHFJW-*5 (13)	315 C	Eng	154												Furnished

† I = Intermittent Torque Only - De-rate Torque Rating 30% for Continuous Duty.

C = Continuous or Intermittent Torque - No need to De-Rate Torque Rating.

IMPORTANT: Refer to the back of this transmission section and read all notes associated with this application page. Some notes may affect the proper PTO selection.

CAUTION: Chelsea Recommends the Power Take-Off (PTO) installation on the 3000/4000 Series Transmissions to utilize a Vehicle Interface Module, or Chassis Manufacturer's equivalent controller to incorporate all the PTO control features available, this includes the "PTO Request" and "PTO Enable Output" feature. The "PTO Enable" circuit signals the Transmission Control Module (TCM) to maintain line pressure to the PTO. Failure to provide this signal may not be sufficient to the PTO. This may cause damage to the PTO and /or Transmission. Please see the Allison Transmission website and individual chassis manufacturer for installation details.

(12) Input Gear Part No. 5-P-1428-7X
(13) Input Gear Part No. 5-P-1428-8X

Allison

CHELSEA®

ALLISON

ALL-14

4000 EVS 4000 MH 4000 RDS 4000 TRV 4430 4430 SP 4440 4500 EVS	4500 RDS B 500 HD-4060P (Close Ratio) HD-4070P HD-4560P (Wide Ratio)
--	--

LEFT SIDE ONLY

TOP SIDE ONLY

TRANSMISSION GEAR DATA:

L.S. 10-BOLT Opening Gear FORWARD of Centerline
97 Teeth - L.H. HELIX

PITCH LINE TO APERTURE FACE:

1.7799" (45.2100MM)

TRANSMISSION GEAR DATA:

TOP 10-BOLT Opening Gear FORWARD of Centerline
97 Teeth - L.H. HELIX

PITCH LINE TO APERTURE FACE:

1.7799" (45.2100MM)

CAUTION: Application Approval Required for PTO Output Shaft Speeds Above 2500 RPM

PTO Model	Torq I / C †	Dir Rot	Engine %		Filler Block	Adapter Assy	Stud Kit	PTO Model	Torq I / C †	Dir Rot	Engine %		Filler Block	Adapter Assy	Stud Kit
			Fwd	Rev							Fwd	Rev			

ONE SPEED - TWO GEAR - CONSTANT MESH

267SBFJP-5 (4)	402 I	Eng	103				Furnished	267SBFJP-3 (4)	402 I	Eng	103				Furnished
267SDFJP-5 (3)	390 I	Eng	123				Furnished	267SDFJP-3 (4)	390 I	Eng	123				Furnished
267SGFJP-5 (2)	360 I	Eng	147				Furnished	267SGFJP-3 (2)	360 I	Eng	147				Furnished
267SMFJP-5 (5)	318 I	Eng	184				Furnished	267SMFJP-3 (5)	318 I	Eng	184				Furnished
267SSFJP-5 (1)	265 I	Eng	229				Furnished	267SSFJP-3 (1)	265 I	Eng	229				Furnished
267XBFJP-5 (23)	335 I	Eng	103				Furnished	267XBFJP-3 (23)	335 I	Eng	103				Furnished
267XDFJP-5 (24)	325 I	Eng	123				Furnished	267XDFJP-3 (24)	325 I	Eng	123				Furnished
267XGFJP-5 (25)	300 I	Eng	147				Furnished	267XGFJP-3 (25)	300 I	Eng	147				Furnished
267XMFJP-5 (26)	265 I	Eng	184				Furnished	267XMFJP-3 (26)	265 I	Eng	184				Furnished
267XSFJP-5 (1)	250 I	Eng	229				Furnished	267XSFJP-3 (1)	250 I	Eng	229				Furnished
287GBFJP-5 (15)	300 C	Eng	85				Furnished	287GBFJP-5 (15)	300 C	Eng	85				Furnished
287GBFJP-8 (15)	300 C	Eng	81				Furnished	287GBFJP-8 (15)	300 C	Eng	81				Furnished
287GCFJP-5 (16)	390 C	Eng	103				Furnished	287GCFJP-5 (16)	390 C	Eng	103				Furnished
287GCFJP-8 (16)	390 C	Eng	97				Furnished	287GCFJP-8 (16)	390 C	Eng	97				Furnished
287GDFJP-5 (17)	390 C	Eng	123				Furnished	287GDFJP-5 (17)	390 C	Eng	123				Furnished
287GDFJP-8 (17)	390 C	Eng	116				Furnished	287GDFJP-8 (17)	390 C	Eng	116				Furnished
287GGFJP-5 (18)	360 C	Eng	147				Furnished	287GGFJP-5 (18)	360 C	Eng	147				Furnished
287GGFJP-8 (18)	360 C	Eng	137				Furnished	287GGFJP-8 (18)	360 C	Eng	137				Furnished
287GKFJP-5 (19)	340 C	Eng	164				Furnished	287GKFJP-5 (19)	340 C	Eng	164				Furnished
287GMFJP-5 (20)	318 C	Eng	184				Furnished	287GMFJP-5 (20)	318 C	Eng	184				Furnished
287GMFJP-8 (20)	318 C	Eng	170				Furnished	287GMFJP-8 (20)	318 C	Eng	170				Furnished
287GPFJP-5 (21)	290 C	Eng	205				Furnished	287GPFJP-5 (21)	290 C	Eng	205				Furnished
287GPFJP-8 (21)	290 C	Eng	189				Furnished	287GPFJP-8 (21)	290 C	Eng	189				Furnished
287GSFJP-5 (22)	265 C	Eng	229				Furnished	287GSFJP-5 (22)	265 C	Eng	229				Furnished
287GSFJP-8 (22)	265 C	Eng	210				Furnished	287GSFJP-8 (22)	265 C	Eng	210				Furnished
877XAFJP-5 (6)	591 C	Eng	116				Furnished	877XAFJP-3 (6)	591 C	Eng	116				Furnished
877XBFJP-5 (7)	552 C	Eng	124				Furnished	877XBFJP-3 (7)	552 C	Eng	124				Furnished
877XCFJP-5 (8)	515 C	Eng	133				Furnished	877XCFJP-3 (8)	515 C	Eng	133				Furnished
877XDFJP-5 (9)	482 C	Eng	142				Furnished	877XDFJP-3 (9)	482 C	Eng	142				Furnished
877XEFJP-5 (10)	425 C	Eng	161				Furnished	877XEFJP-3 (10)	425 C	Eng	161				Furnished
877XFFJP-5 (11)	376 C	Eng	182				Furnished	877XFFJP-3 (11)	376 C	Eng	182				Furnished
877XGFJP-5 (12)	332 C	Eng	207				Furnished	877XGFJP-3 (12)	332 C	Eng	207				Furnished

Continued on Next Page

† I = Intermittent Torque Only - De-rate Torque Rating 30% for Continuous Duty.

C = Continuous or Intermittent Torque - No need to De-Rate Torque Rating.

IMPORTANT: Refer to the back of this transmission section and read all notes associated with this application page. Some notes may affect the proper PTO selection.

CAUTION: Chelsea Recommends the Power Take-Off (PTO) installation on the 3000/4000 Series Transmissions to utilize a Vehicle Interface Module, or Chassis Manufacturer's equivalent controller to incorporate all the PTO control features available, this includes the "PTO Request" and "PTO Enable Output" feature. The "PTO Enable" circuit signals the Transmission Control Module (TCM) to maintain line pressure to the PTO. Failure to provide this signal may not be sufficient to the PTO. This may cause damage to the PTO and /or Transmission. Please see the Allison Transmission website and individual chassis manufacturer for installation details.

CAUTION: The torque values given for specific application pages may be limited to the rated torque of the Allison transmission.

- (1) Input Gear Part No. 5-P-1173
(2) Input Gear Part No. 5-P-1225
(3) Input Gear Part No. 5-P-1293
(4) Input Gear Part No. 5-P-1350
(5) Input Gear Part No. 5-P-1351
(6) Input Gear Part No. 5-P-1428-11X

- (7) Input Gear Part No. 5-P-1428-12X
(8) Input Gear Part No. 5-P-1428-3X
(9) Input Gear Part No. 5-P-1428-4X
(10) Input Gear Part No. 5-P-1428-5X
(11) Input Gear Part No. 5-P-1428-6X
(12) Input Gear Part No. 5-P-1428-7X

- (15) Input Gear Part No. 5-P-1491-1X
(16) Input Gear Part No. 5-P-1491-2X
(17) Input Gear Part No. 5-P-1491-3X
(18) Input Gear Part No. 5-P-1491-4X
(19) Input Gear Part No. 5-P-1491-5X
(20) Input Gear Part No. 5-P-1491-6X

- (21) Input Gear Part No. 5-P-1491-7X
(22) Input Gear Part No. 5-P-1491-8X
(23) Input Gear Part No. 5-P-912
(24) Input Gear Part No. 5-P-913
(25) Input Gear Part No. 5-P-914
(26) Input Gear Part No. 5-P-915

ALL-14

ALLISON

CHELSEA®

4000 EVS 4000 MH 4000 RDS 4000 TRV 4430 4430 ORS 4430 SP 4440	4500 EVS 4500 RDS B 500 HD-4060P (Close Ratio) HD-4070P HD-4560P (Wide Ratio)
--	--

LEFT SIDE ONLY	TOP SIDE ONLY
TRANSMISSION GEAR DATA: L.S. 10-BOLT Opening Gear FORWARD of Centerline 97 Teeth - L.H. HELIX PITCH LINE TO APERTURE FACE: 1.7799" (45.2100MM)	TRANSMISSION GEAR DATA: TOP 10-BOLT Opening Gear FORWARD of Centerline 97 Teeth - L.H. HELIX PITCH LINE TO APERTURE FACE: 1.7799" (45.2100MM)

CAUTION: Application Approval Required for PTO Output Shaft Speeds Above 2500 RPM

PTO Model	Torq l / C †	Dir Rot	Engine %		Filler Block	Adapter Assy	Stud Kit	PTO Model	Torq l / C †	Dir Rot	Engine %		Filler Block	Adapter Assy	Stud Kit
			Fwd	Rev							Fwd	Rev			

ONE SPEED - TWO GEAR - CONSTANT MESH

877XHFJP-*5 (13)	312 C	Eng	220				Furnished	877XHFJP-*3 (13)	312 C	Eng	220				Furnished
877XJFJP-*5 (14)	293 C	Eng	234				Furnished	877XJFJP-*3 (14)	293 C	Eng	234				Furnished

ONE SPEED - TWO GEAR - POWERSHIFT (HYDRAULIC)

280GBFJP-*5 (15)	300 C	Eng	85				Furnished	280GBFJP-*5 (15)	300 C	Eng	85				Furnished
280GBFJP-*8 (15)	300 C	Eng	81				Furnished	280GBFJP-*8 (15)	300 C	Eng	81				Furnished
280GCFJP-*5 (16)	390 C	Eng	103				Furnished	280GCFJP-*5 (16)	390 C	Eng	103				Furnished
280GCFJP-*8 (16)	390 C	Eng	97				Furnished	280GCFJP-*8 (16)	390 C	Eng	97				Furnished
280GDFJP-*5 (17)	390 C	Eng	123				Furnished	280GDFJP-*5 (17)	390 C	Eng	123				Furnished
280GDFJP-*8 (17)	390 C	Eng	116				Furnished	280GDFJP-*8 (17)	390 C	Eng	116				Furnished
280GGFJP-*5 (18)	360 C	Eng	147				Furnished	280GGFJP-*5 (18)	360 C	Eng	147				Furnished
280GGFJP-*8 (18)	360 C	Eng	137				Furnished	280GGFJP-*8 (18)	360 C	Eng	137				Furnished
280GKFJP-*5 (19)	340 C	Eng	164				Furnished	280GKFJP-*5 (19)	340 C	Eng	164				Furnished
280GMFJP-*5 (20)	318 C	Eng	184				Furnished	280GMFJP-*5 (20)	318 C	Eng	184				Furnished
280GMFJP-*8 (20)	318 C	Eng	170				Furnished	280GMFJP-*8 (20)	318 C	Eng	170				Furnished
280GPFJP-*5 (21)	290 C	Eng	205				Furnished	280GPFJP-*5 (21)	290 C	Eng	205				Furnished
280GPFJP-*8 (21)	290 C	Eng	189				Furnished	280GPFJP-*8 (21)	290 C	Eng	189				Furnished
280GSFJP-*5 (22)	265 C	Eng	229				Furnished	280GSFJP-*5 (22)	265 C	Eng	229				Furnished
280GSFJP-*8 (22)	265 C	Eng	210				Furnished	280GSFJP-*8 (22)	265 C	Eng	210				Furnished
870XAFJP-*5 (6)	591 C	Eng	116				Furnished	870XAFJP-*5 (6)	591 C	Eng	116				Furnished
870XBFJP-*5 (7)	552 C	Eng	124				Furnished	870XBFJP-*5 (7)	552 C	Eng	124				Furnished
870XCFJP-*5 (8)	515 C	Eng	133				Furnished	870XCFJP-*5 (8)	515 C	Eng	133				Furnished
870XDFJP-*5 (9)	482 C	Eng	142				Furnished	870XDFJP-*5 (9)	482 C	Eng	142				Furnished
870XEFJP-*5 (10)	425 C	Eng	161				Furnished	870XEFJP-*5 (10)	425 C	Eng	161				Furnished
870XFFJP-*5 (11)	376 C	Eng	182				Furnished	870XFFJP-*5 (11)	376 C	Eng	182				Furnished
870XGFJP-*5 (12)	332 C	Eng	207				Furnished	870XGFJP-*5 (12)	332 C	Eng	207				Furnished
870XHFJP-*5 (13)	312 C	Eng	220				Furnished	870XHFJP-*5 (13)	312 C	Eng	220				Furnished
870XJFJP-*5 (14)	293 C	Eng	234				Furnished	870XJFJP-*5 (14)	293 C	Eng	234				Furnished

ONE SPEED - POWERSHIFT (HYDRAULIC) EXTENDED SHAFT

870LAFJW-*5 (6)	591	Eng	116				Furnished	890UAFJW-*5 (6)	591	Eng	116				Furnished
870LBFJW-*5 (7)	552	Eng	124				Furnished	890UBFJW-*5 (7)	552	Eng	124				Furnished

Continued on Next Page

† I = Intermittent Torque Only - De-rate Torque Rating 30% for Continuous Duty.

C = Continuous or Intermittent Torque - No need to De-Rate Torque Rating.

IMPORTANT: Refer to the back of this transmission section and read all notes associated with this application page. Some notes may affect the proper PTO selection.

CAUTION: Chelsea Recommends the Power Take-Off (PTO) installation on the 3000/4000 Series Transmissions to utilize a Vehicle Interface Module, or Chassis Manufacturer's equivalent controller to incorporate all the PTO control features available, this includes the "PTO Request" and "PTO Enable Output" feature. The "PTO Enable" circuit signals the Transmission Control Module (TCM) to maintain line pressure to the PTO. Failure to provide this signal may not be sufficient to the PTO. This may cause damage to the PTO and /or Transmission. Please see the Allison Transmission website and individual chassis manufacturer for installation details.

CAUTION: The torque values given for specific application pages may be limited to the rated torque of the Allison transmission.

- | | | |
|--------------------------------------|--------------------------------------|--------------------------------------|
| (6) Input Gear Part No. 5-P-1428-11X | (12) Input Gear Part No. 5-P-1428-7X | (18) Input Gear Part No. 5-P-1491-4X |
| (7) Input Gear Part No. 5-P-1428-12X | (13) Input Gear Part No. 5-P-1428-8X | (19) Input Gear Part No. 5-P-1491-5X |
| (8) Input Gear Part No. 5-P-1428-3X | (14) Input Gear Part No. 5-P-1428-9X | (20) Input Gear Part No. 5-P-1491-6X |
| (9) Input Gear Part No. 5-P-1428-4X | (15) Input Gear Part No. 5-P-1491-1X | (21) Input Gear Part No. 5-P-1491-7X |
| (10) Input Gear Part No. 5-P-1428-5X | (16) Input Gear Part No. 5-P-1491-2X | (22) Input Gear Part No. 5-P-1491-8X |
| (11) Input Gear Part No. 5-P-1428-6X | (17) Input Gear Part No. 5-P-1491-3X | |

Allison

CHELSEA®

ALLISON

ALL-14

4000 EVS	4500 EVS
4000 MH	4500 RDS
4000 RDS	B 500
4000 TRV	HD-4060P (Close Ratio)
4430	HD-4070P
4430 ORS	HD-4560P (Wide Ratio)
4430 SP	
4440	

LEFT SIDE ONLY

TOP SIDE ONLY

TRANSMISSION GEAR DATA:

L.S. 10-BOLT Opening Gear FORWARD of Centerline
97 Teeth - L.H. HELIX

PITCH LINE TO APERTURE FACE:

1.7799" (45.2100MM)

TRANSMISSION GEAR DATA:

TOP 10-BOLT Opening Gear FORWARD of Centerline
97 Teeth - L.H. HELIX

PITCH LINE TO APERTURE FACE:

1.7799" (45.2100MM)

CAUTION: Application Approval Required for PTO Output Shaft Speeds Above 2500 RPM

PTO Model	Torq I / C †	Dir Rot	Engine %		Filler Block	Adapter Assy	Stud Kit	PTO Model	Torq I / C †	Dir Rot	Engine %		Filler Block	Adapter Assy	Stud Kit
			Fwd	Rev							Fwd	Rev			

ONE SPEED - POWERSHIFT (HYDRAULIC) EXTENDED SHAFT

870LCFJW-*5 (8)	515	Eng	133				Furnished	890UCFJW-*5 (8)	515 C	Eng	133				Furnished
870LDFJW-*5 (9)	482	Eng	142				Furnished	890UDFJW-*5 (9)	482 C	Eng	142				Furnished
870LEFJW-*5 (10)	425	Eng	161				Furnished	890UEFJW-*5 (10)	425 C	Eng	161				Furnished
870LFFJW-*5 (11)	376	Eng	182				Furnished	890UFFJW-*5 (11)	376 C	Eng	182				Furnished
890HAFJW-*5 (6)	591 C	Eng	116				Furnished								
890HBFJW-*5 (7)	552 C	Eng	124				Furnished								
890HCFJW-*5 (8)	515 C	Eng	133				Furnished								
890HDFJW-*5 (9)	482 C	Eng	142				Furnished								
890HEFJW-*5 (10)	425 C	Eng	161				Furnished								
890HFFJW-*5 (11)	376 C	Eng	182				Furnished								

ONE SPEED - CONSTANT MESH EXTENDED SHAFT

877LAFJW-*5 (6)	591	Eng	116				Furnished	897UAFJW-*5 (6)	591 C	Eng	116				Furnished
877LBFJW-*5 (7)	552	Eng	124				Furnished	897UBFJW-*5 (7)	552 C	Eng	124				Furnished
877LCFJW-*5 (8)	515	Eng	133				Furnished	897UCFJW-*5 (8)	515 C	Eng	133				Furnished
877LDFJW-*5 (9)	482	Eng	142				Furnished	897UDFJW-*5 (9)	482 C	Eng	142				Furnished
877LEFJW-*5 (10)	425	Eng	161				Furnished	897UEFJW-*5 (10)	425 C	Eng	161				Furnished
877LFFJW-*5 (11)	376	Eng	182				Furnished	897UFFJW-*5 (11)	376 C	Eng	182				Furnished
897HAFJW-*5 (6)	591 C	Eng	116				Furnished								
897HBFJW-*5 (7)	552 C	Eng	124				Furnished								
897HCFJW-*5 (8)	515 C	Eng	133				Furnished								
897HDFJW-*5 (9)	482 C	Eng	142				Furnished								
897HEFJW-*5 (10)	425 C	Eng	161				Furnished								
897HFFJW-*5 (11)	376 C	Eng	182				Furnished								

† I = Intermittent Torque Only - De-rate Torque Rating 30% for Continuous Duty.

C = Continuous or Intermittent Torque - No need to De-Rate Torque Rating.

IMPORTANT: Refer to the back of this transmission section and read all notes associated with this application page. Some notes may affect the proper PTO selection.

CAUTION: Chelsea Recommends the Power Take-Off (PTO) installation on the 3000/4000 Series Transmissions to utilize a Vehicle Interface Module, or Chassis Manufacturer's equivalent controller to incorporate all the PTO control features available, this includes the "PTO Request" and "PTO Enable Output" feature. The "PTO Enable" circuit signals the Transmission Control Module (TCM) to maintain line pressure to the PTO. Failure to provide this signal may not be sufficient to the PTO. This may cause damage to the PTO and /or Transmission. Please see the Allison Transmission website and individual chassis manufacturer for installation details.

CAUTION: The torque values given for specific application pages may be limited to the rated torque of the Allison transmission.

(6) Input Gear Part No. 5-P-1428-11X
 (7) Input Gear Part No. 5-P-1428-12X
 (8) Input Gear Part No. 5-P-1428-3X
 (9) Input Gear Part No. 5-P-1428-4X
 (10) Input Gear Part No. 5-P-1428-5X
 (11) Input Gear Part No. 5-P-1428-6X

ALL-14C

ALLISON

CHELSEA®

4000 (4000 Family w/ Integral Cooler)

LEFT SIDE ONLY

TOP SIDE ONLY

TRANSMISSION GEAR DATA:

L.S. 10-BOLT Opening Gear FORWARD of Centerline
97 Teeth - L.H. HELIX

PITCH LINE TO APERTURE FACE:

1.7799" (45.2100MM)

TRANSMISSION GEAR DATA:

TOP 10-BOLT Opening Gear FORWARD of Centerline
97 Teeth - L.H. HELIX

PITCH LINE TO APERTURE FACE:

1.7799" (45.2100MM)

CAUTION: Application Approval Required for PTO Output Shaft Speeds Above 2500 RPM

PTO Model	Torq l / C †	Dir Rot	Engine %		Filler Block	Adapter Assy	Stud Kit	PTO Model	Torq l / C †	Dir Rot	Engine %		Filler Block	Adapter Assy	Stud Kit
			Fwd	Rev							Fwd	Rev			

ONE SPEED - TWO GEAR - CONSTANT MESH

267SBFJP-5 (4)	402 l	Eng	103				Furnished	267SBFJP-3 (4)	402 l	Eng	103				Furnished
267SDFJP-5 (3)	390 l	Eng	123				Furnished	267SDFJP-3 (4)	390 l	Eng	123				Furnished
267SGFJP-5 (2)	360 l	Eng	147				Furnished	267SGFJP-3 (2)	360 l	Eng	147				Furnished
267SMFJP-5 (5)	318 l	Eng	184				Furnished	267SMFJP-3 (5)	318 l	Eng	184				Furnished
267SSFJP-5 (1)	265 l	Eng	229				Furnished	267SSFJP-3 (1)	265 l	Eng	229				Furnished
267XBFJP-5 (23)	335 l	Eng	103				Furnished	267XBFJP-3 (23)	335 l	Eng	103				Furnished
267XDFJP-5 (24)	325 l	Eng	123				Furnished	267XDFJP-3 (24)	325 l	Eng	123				Furnished
267XGFJP-5 (25)	300 l	Eng	147				Furnished	267XGFJP-3 (25)	300 l	Eng	147				Furnished
267XMFJP-5 (26)	265 l	Eng	184				Furnished	267XMFJP-3 (26)	265 l	Eng	184				Furnished
267XSFJP-5 (1)	250 l	Eng	229				Furnished	267XSFJP-3 (1)	250 l	Eng	229				Furnished
287GBFJP-5 (15)	300 C	Eng	85				Furnished	287GBFJP-5 (15)	300 C	Eng	85				Furnished
287GBFJP-8 (15)	300 C	Eng	81				Furnished	287GBFJP-8 (15)	300 C	Eng	81				Furnished
287GCFJP-5 (16)	390 C	Eng	103				Furnished	287GCFJP-5 (16)	390 C	Eng	103				Furnished
287GCFJP-8 (16)	390 C	Eng	97				Furnished	287GCFJP-8 (16)	390 C	Eng	97				Furnished
287GDFJP-5 (17)	390 C	Eng	123				Furnished	287GDFJP-5 (17)	390 C	Eng	123				Furnished
287GDFJP-8 (17)	390 C	Eng	116				Furnished	287GDFJP-8 (17)	390 C	Eng	116				Furnished
287GGFJP-5 (18)	360 C	Eng	147				Furnished	287GGFJP-5 (18)	360 C	Eng	147				Furnished
287GGFJP-8 (18)	360 C	Eng	137				Furnished	287GGFJP-8 (18)	360 C	Eng	137				Furnished
287GKFJP-5 (19)	340 C	Eng	164				Furnished	287GKFJP-5 (19)	340 C	Eng	164				Furnished
287GMFJP-5 (20)	318 C	Eng	184				Furnished	287GMFJP-5 (20)	318 C	Eng	184				Furnished
287GMFJP-8 (20)	318 C	Eng	170				Furnished	287GMFJP-8 (20)	318 C	Eng	170				Furnished
287GPFJP-5 (21)	290 C	Eng	205				Furnished	287GPFJP-5 (21)	290 C	Eng	205				Furnished
287GPFJP-8 (21)	290 C	Eng	189				Furnished	287GPFJP-8 (21)	290 C	Eng	189				Furnished
287GSFJP-5 (22)	265 C	Eng	229				Furnished	287GSFJP-5 (22)	265 C	Eng	229				Furnished
287GSFJP-8 (22)	265 C	Eng	210				Furnished	287GSFJP-8 (22)	265 C	Eng	210				Furnished
877XAFJP-5 (6)	591 C	Eng	116				Furnished	877XAFJP-3 (6)	591 C	Eng	116				Furnished
877XBFJP-5 (7)	552 C	Eng	124				Furnished	877XBFJP-3 (7)	552 C	Eng	124				Furnished
877XCFJP-5 (8)	515 C	Eng	133				Furnished	877XCFJP-3 (8)	515 C	Eng	133				Furnished
877XDFJP-5 (9)	482 C	Eng	142				Furnished	877XDFJP-3 (9)	482 C	Eng	142				Furnished
877XEFJP-5 (10)	425 C	Eng	161				Furnished	877XEFJP-3 (10)	425 C	Eng	161				Furnished
877XFFJP-5 (11)	376 C	Eng	182				Furnished	877XFFJP-3 (11)	376 C	Eng	182				Furnished
877XGFJP-5 (12)	332 C	Eng	207				Furnished	877XGFJP-3 (12)	332 C	Eng	207				Furnished

Continued on Next Page

† I = Intermittent Torque Only - De-rate Torque Rating 30% for Continuous Duty.

C = Continuous or Intermittent Torque - No need to De-Rate Torque Rating.

IMPORTANT: Refer to the back of this transmission section and read all notes associated with this application page. Some notes may affect the proper PTO selection.

CAUTION: Chelsea Recommends the Power Take-Off (PTO) installation on the 3000/4000 Series Transmissions to utilize a Vehicle Interface Module, or Chassis Manufacturer's equivalent controller to incorporate all the PTO control features available, this includes the "PTO Request" and "PTO Enable Output" feature. The "PTO Enable" circuit signals the Transmission Control Module (TCM) to maintain line pressure to the PTO. Failure to provide this signal may not be sufficient to the PTO. This may cause damage to the PTO and /or Transmission. Please see the Allison Transmission website and individual chassis manufacturer for installation details.

CAUTION: The torque values given for specific application pages may be limited to the rated torque of the Allison transmission.

- | | | | |
|--------------------------------------|--------------------------------------|--------------------------------------|--------------------------------------|
| (1) Input Gear Part No. 5-P-1173 | (7) Input Gear Part No. 5-P-1428-12X | (15) Input Gear Part No. 5-P-1491-1X | (21) Input Gear Part No. 5-P-1491-7X |
| (2) Input Gear Part No. 5-P-1225 | (8) Input Gear Part No. 5-P-1428-3X | (16) Input Gear Part No. 5-P-1491-2X | (22) Input Gear Part No. 5-P-1491-8X |
| (3) Input Gear Part No. 5-P-1293 | (9) Input Gear Part No. 5-P-1428-4X | (17) Input Gear Part No. 5-P-1491-3X | (23) Input Gear Part No. 5-P-912 |
| (4) Input Gear Part No. 5-P-1350 | (10) Input Gear Part No. 5-P-1428-5X | (18) Input Gear Part No. 5-P-1491-4X | (24) Input Gear Part No. 5-P-913 |
| (5) Input Gear Part No. 5-P-1351 | (11) Input Gear Part No. 5-P-1428-6X | (19) Input Gear Part No. 5-P-1491-5X | (25) Input Gear Part No. 5-P-914 |
| (6) Input Gear Part No. 5-P-1428-11X | (12) Input Gear Part No. 5-P-1428-7X | (20) Input Gear Part No. 5-P-1491-6X | (26) Input Gear Part No. 5-P-915 |

Allison



October 2022
5.2.30

Parker Hannifin Corporation
Chelsea Products Division
Olive Branch, MS 38654 USA

4000 (4000 Family w/ Integral Cooler)

LEFT SIDE ONLY

TOP SIDE ONLY

TRANSMISSION GEAR DATA:

L.S. 10-BOLT Opening Gear FORWARD of Centerline
97 Teeth - L.H. HELIX

PITCH LINE TO APERTURE FACE:

1.7799" (45.2100MM)

TRANSMISSION GEAR DATA:

TOP 10-BOLT Opening Gear FORWARD of Centerline
97 Teeth - L.H. HELIX

PITCH LINE TO APERTURE FACE:

1.7799" (45.2100MM)

CAUTION: Application Approval Required for PTO Output Shaft Speeds Above 2500 RPM

PTO Model	Torq I / C †	Dir Rot	Engine %		Filler Block	Adapter Assy	Stud Kit	PTO Model	Torq I / C †	Dir Rot	Engine %		Filler Block	Adapter Assy	Stud Kit
			Fwd	Rev							Fwd	Rev			

ONE SPEED - TWO GEAR - CONSTANT MESH

877XHFJP-*5 (13)	312 C	Eng	220				Furnished	877XHFJP-*3 (13)	312 C	Eng	220				Furnished
877XJFJP-*5 (14)	293 C	Eng	234				Furnished	877XJFJP-*3 (14)	293 C	Eng	234				Furnished

ONE SPEED - TWO GEAR - POWERSHIFT (HYDRAULIC)

280GBFJP-*5 (15)	300 C	Eng	85				Furnished	280GBFJP-*5 (15)	300 C	Eng	85				Furnished
280GBFJP-*8 (15)	300 C	Eng	81				Furnished	8280GBFJP-*8 (15)	300 C	Eng	81				Furnished
280GCFJP-*5 (16)	390 C	Eng	103				Furnished	280GCFJP-*5 (16)	390 C	Eng	103				Furnished
280GCFJP-*8 (16)	390 C	Eng	97				Furnished	280GCFJP-*8 (16)	390 C	Eng	97				Furnished
280GDFJP-*5 (17)	390 C	Eng	123				Furnished	280GDFJP-*5 (17)	390 C	Eng	123				Furnished
280GDFJP-*8 (17)	390 C	Eng	116				Furnished	280GDFJP-*8 (17)	390 C	Eng	116				Furnished
280GGFJP-*5 (18)	360 C	Eng	147				Furnished	280GGFJP-*5 (18)	360 C	Eng	147				Furnished
280GGFJP-*8 (18)	360 C	Eng	137				Furnished	280GGFJP-*8 (18)	360 C	Eng	137				Furnished
280GKFJP-*5 (19)	340 C	Eng	164				Furnished	280GKFJP-*5 (19)	340 C	Eng	164				Furnished
280GMFJP-*5 (20)	318 C	Eng	184				Furnished	280GMFJP-*5 (20)	318 C	Eng	184				Furnished
280GMFJP-*8 (20)	318 C	Eng	170				Furnished	280GMFJP-*8 (20)	318 C	Eng	170				Furnished
280GPFJP-*5 (21)	290 C	Eng	205				Furnished	280GPFJP-*5 (21)	290 C	Eng	205				Furnished
280GPFJP-*8 (21)	290 C	Eng	189				Furnished	280GPFJP-*8 (21)	290 C	Eng	189				Furnished
280GSFJP-*5 (22)	265 C	Eng	229				Furnished	280GSFJP-*5 (22)	265 C	Eng	229				Furnished
280GSFJP-*8 (22)	265 C	Eng	210				Furnished	280GSFJP-*8 (22)	265 C	Eng	210				Furnished
870XAFJP-*5 (6)	591 C	Eng	116				Furnished	870XAFJP-*3 (6)	591 C	Eng	116				Furnished
870XBFJP-*5 (7)	552 C	Eng	124				Furnished	870XBFJP-*3 (7)	552 C	Eng	124				Furnished
870XCFJP-*5 (8)	515 C	Eng	133				Furnished	870XCFJP-*3 (8)	515 C	Eng	133				Furnished
870XDFJP-*5 (9)	482 C	Eng	142				Furnished	870XDFJP-*3 (9)	482 C	Eng	142				Furnished
870XEFJP-*5 (10)	425 C	Eng	161				Furnished	870XEFJP-*3 (10)	425 C	Eng	161				Furnished
870XFFJP-*5 (11)	376 C	Eng	182				Furnished	870XFFJP-*3 (11)	376 C	Eng	182				Furnished
870XGFJP-*5 (12)	332 C	Eng	207				Furnished	870XGFJP-*3 (12)	332 C	Eng	207				Furnished
870XHFJP-*5 (13)	312 C	Eng	220				Furnished	870XHFJP-*3 (13)	312 C	Eng	220				Furnished
870XJFJP-*5 (14)	293 C	Eng	234				Furnished	870XJFJP-*3 (14)	293 C	Eng	234				Furnished

ONE SPEED - POWERSHIFT (HYDRAULIC) EXTENDED SHAFT

870LAFJW-*3 (6)	591 C	Eng	116				Furnished	890UAFJW-*5 (6)	591 C	Eng	116				Furnished
870LBFJW-*3 (7)	552 C	Eng	124				Furnished	890UBFJW-*5 (7)	552 C	Eng	124				Furnished

Continued on Next Page

† I = Intermittent Torque Only - De-rate Torque Rating 30% for Continuous Duty.

C = Continuous or Intermittent Torque - No need to De-Rate Torque Rating.

IMPORTANT: Refer to the back of this transmission section and read all notes associated with this application page. Some notes may affect the proper PTO selection.

CAUTION: Chelsea Recommends the Power Take-Off (PTO) installation on the 3000/4000 Series Transmissions to utilize a Vehicle Interface Module, or Chassis Manufacturer's equivalent controller to incorporate all the PTO control features available, this includes the "PTO Request" and "PTO Enable Output" feature. The "PTO Enable" circuit signals the Transmission Control Module (TCM) to maintain line pressure to the PTO. Failure to provide this signal may not be sufficient to the PTO. This may cause damage to the PTO and /or Transmission. Please see the Allison Transmission website and individual chassis manufacturer for installation details.

CAUTION: The torque values given for specific application pages may be limited to the rated torque of the Allison transmission.

- | | | |
|--------------------------------------|--------------------------------------|--------------------------------------|
| (6) Input Gear Part No. 5-P-1428-11X | (12) Input Gear Part No. 5-P-1428-7X | (18) Input Gear Part No. 5-P-1491-4X |
| (7) Input Gear Part No. 5-P-1428-12X | (13) Input Gear Part No. 5-P-1428-8X | (19) Input Gear Part No. 5-P-1491-5X |
| (8) Input Gear Part No. 5-P-1428-3X | (14) Input Gear Part No. 5-P-1428-9X | (20) Input Gear Part No. 5-P-1491-6X |
| (9) Input Gear Part No. 5-P-1428-4X | (15) Input Gear Part No. 5-P-1491-1X | (21) Input Gear Part No. 5-P-1491-7X |
| (10) Input Gear Part No. 5-P-1428-5X | (16) Input Gear Part No. 5-P-1491-2X | (22) Input Gear Part No. 5-P-1491-8X |
| (11) Input Gear Part No. 5-P-1428-6X | (17) Input Gear Part No. 5-P-1491-3X | |

ALL-14C

ALLISON

CHELSEA®

4000 (4000 Family w/ Integral Cooler)

LEFT SIDE ONLY

TOP SIDE ONLY

TRANSMISSION GEAR DATA:

L.S. 10-BOLT Opening Gear FORWARD of Centerline
97 Teeth - L.H. HELIX

PITCH LINE TO APERTURE FACE:

1.7799" (45.2100MM)

TRANSMISSION GEAR DATA:

TOP 10-BOLT Opening Gear FORWARD of Centerline
97 Teeth - L.H. HELIX

PITCH LINE TO APERTURE FACE:

1.7799" (45.2100MM)

CAUTION: Application Approval Required for PTO Output Shaft Speeds Above 2500 RPM

PTO Model	Torq I / C †	Dir Rot	Engine %		Filler Block	Adapter Assy	Stud Kit	PTO Model	Torq I / C †	Dir Rot	Engine %		Filler Block	Adapter Assy	Stud Kit
			Fwd	Rev							Fwd	Rev			

ONE SPEED - POWERSHIFT (HYDRAULIC) EXTENDED SHAFT

870LCFJP-*3 (8)	515 C	Eng	133				Furnished	890UCFJW-*5 (8)	515 C	Eng	133				Furnished
870LDFJW-*3 (9)	482 C	Eng	142				Furnished	890UDFJW-*5 (9)	482 C	Eng	142				Furnished
870LEFJW-*3 (10)	425 C	Eng	161				Furnished	890UEFJW-*5 (10)	425 C	Eng	161				Furnished
870LFFJW-*3 (11)	376 C	Eng	182				Furnished	890UFFJW-*5 (11)	376 C	Eng	182				Furnished
890CAFJW-*3 (6)	591 C	Eng	116				Furnished								
890CBFJW-*3 (7)	552 C	Eng	124				Furnished								
890CCFJW-*3 (8)	515 C	Eng	133				Furnished								
890CDFJW-*3 (9)	482 C	Eng	142				Furnished								
890CEFJW-*3 (10)	425 C	Eng	161				Furnished								
890CFJW-*3 (11)	376 C	Eng	182				Furnished								

ONE SPEED - CONSTANT MESH EXTENDED SHAFT

877LAFJW-*3 (6)	591 C	Eng	116				Furnished	897UAFJW-*3 (6)	591 C	Eng	116				Furnished
877LBFJW-*3 (7)	552 C	Eng	124				Furnished	897UBFJW-*5 (7)	552 C	Eng	124				Furnished
877LCFJW-*3 (8)	515 C	Eng	133				Furnished	897UCFJW-*5 (8)	515 C	Eng	133				Furnished
877LDFJW-*3 (9)	482 C	Eng	142				Furnished	897UDFJW-*5 (9)	482 C	Eng	142				Furnished
877LEFJW-*3 (10)	425 C	Eng	161				Furnished	897UEFJW-*5 (10)	425 C	Eng	161				Furnished
877LFFJW-*3 (11)	376 C	Eng	182				Furnished	897UFFJW-*5 (11)	376 C	Eng	182				Furnished
897CAFJW-*3 (6)	591 C	Eng	116				Furnished								
897CBFJW-*3 (7)	552 C	Eng	124				Furnished								
897CCFJW-*3 (8)	515 C	Eng	133				Furnished								
897CDFJW-*3 (9)	482 C	Eng	142				Furnished								
897CEFJW-*3 (10)	425 C	Eng	161				Furnished								
897CFJW-*3 (11)	376 C	Eng	182				Furnished								

† I = Intermittent Torque Only - De-rate Torque Rating 30% for Continuous Duty.

C = Continuous or Intermittent Torque - No need to De-Rate Torque Rating.

IMPORTANT: Refer to the back of this transmission section and read all notes associated with this application page. Some notes may affect the proper PTO selection.

CAUTION: Chelsea Recommends the Power Take-Off (PTO) installation on the 3000/4000 Series Transmissions to utilize a Vehicle Interface Module, or Chassis Manufacturer's equivalent controller to incorporate all the PTO control features available, this includes the "PTO Request" and "PTO Enable Output" feature. The "PTO Enable" circuit signals the Transmission Control Module (TCM) to maintain line pressure to the PTO. Failure to provide this signal may not be sufficient to the PTO. This may cause damage to the PTO and /or Transmission. Please see the Allison Transmission website and individual chassis manufacturer for installation details.

CAUTION: The torque values given for specific application pages may be limited to the rated torque of the Allison transmission.

- (6) Input Gear Part No. 5-P-1428-11X
 (7) Input Gear Part No. 5-P-1428-12X
 (8) Input Gear Part No. 5-P-1428-3X
 (9) Input Gear Part No. 5-P-1428-4X
 (10) Input Gear Part No. 5-P-1428-5X
 (11) Input Gear Part No. 5-P-1428-6X

4000 (4000 Family w/ Retarder)

LEFT SIDE ONLY

TOP SIDE ONLY

TRANSMISSION GEAR DATA:

L.S. 10-BOLT Opening Gear FORWARD of Centerline
97 Teeth - L.H. HELIX

PITCH LINE TO APERTURE FACE:

1.7799" (45.2100MM)

TRANSMISSION GEAR DATA:

TOP 10-BOLT Opening Gear FORWARD of Centerline
97 Teeth - L.H. HELIX

PITCH LINE TO APERTURE FACE:

1.7799" (45.2100MM)

CAUTION: Application Approval Required for PTO Output Shaft Speeds Above 2500 RPM

PTO Model	Torq I / C †	Dir Rot	Engine %		Filler Block	Adapter Assy	Stud Kit	PTO Model	Torq I / C †	Dir Rot	Engine %		Filler Block	Adapter Assy	Stud Kit
			Fwd	Rev							Fwd	Rev			

ONE SPEED - TWO GEAR - CONSTANT MESH

267SBFJP-*5 (4)	402 I	Eng	103				Furnished	267SBFJP-*3 (4)	402 I	Eng	103				Furnished
267SDFJP-*5 (3)	390 I	Eng	123				Furnished	267SDFJP-*3 (4)	390 I	Eng	123				Furnished
267SGFJP-*5 (2)	360 I	Eng	147				Furnished	267SGFJP-*3 (2)	360 I	Eng	147				Furnished
267SMFJP-*5 (5)	318 I	Eng	184				Furnished	267SMFJP-*3 (5)	318 I	Eng	184				Furnished
267SSFJP-*5 (1)	265 I	Eng	229				Furnished	267SSFJP-*3 (1)	265 I	Eng	229				Furnished
267XBFJP-*5 (23)	335 I	Eng	103				Furnished	267XBFJP-*3 (23)	335 I	Eng	103				Furnished
267XDFJP-*5 (24)	325 I	Eng	123				Furnished	267XDFJP-*5 (24)	325 I	Eng	123				Furnished
267XGFJP-*5 (25)	300 I	Eng	147				Furnished	267XGFJP-*3 (25)	300 I	Eng	147				Furnished
267XMFJP-*5 (26)	265 I	Eng	184				Furnished	267XMFJP-*3 (26)	265 I	Eng	184				Furnished
267XSFJP-*5 (1)	250 I	Eng	229				Furnished	267XSFJP-*3 (1)	250 I	Eng	229				Furnished
287GBFJP-*5 (15)	300 C	Eng	85				Furnished	287GBFJP-*5 (15)	300 C	Eng	85				Furnished
287GBFJP-*8 (15)	300 C	Eng	81				Furnished	287GBFJP-*8 (15)	300 C	Eng	81				Furnished
287GCFJP-*5 (16)	390 C	Eng	103				Furnished	287GCFJP-*5 (16)	390 C	Eng	103				Furnished
287GCFJP-*8 (16)	390 C	Eng	97				Furnished	287GCFJP-*8 (16)	390 C	Eng	97				Furnished
287GDFJP-*5 (17)	390 C	Eng	123				Furnished	287GDFJP-*5 (17)	390 C	Eng	123				Furnished
287GDFJP-*8 (17)	390 C	Eng	116				Furnished	287GDFJP-*8 (17)	390 C	Eng	116				Furnished
287GGFJP-*5 (18)	360 C	Eng	147				Furnished	287GGFJP-*5 (18)	360 C	Eng	147				Furnished
287GGFJP-*8 (18)	360 C	Eng	137				Furnished	287GGFJP-*8 (18)	360 C	Eng	137				Furnished
287GKFJP-*5 (19)	340 C	Eng	164				Furnished	287GKFJP-*5 (19)	340 C	Eng	164				Furnished
287GMFJP-*5 (20)	318 C	Eng	184				Furnished	287GMFJP-*5 (20)	318 C	Eng	184				Furnished
287GMFJP-*8 (20)	318 C	Eng	170				Furnished	287GMFJP-*8 (20)	318 C	Eng	170				Furnished
287GPFJP-*5 (21)	290 C	Eng	205				Furnished	287GPFJP-*5 (21)	290 C	Eng	205				Furnished
287GPFJP-*8 (21)	290 C	Eng	189				Furnished	287GPFJP-*8 (21)	290 C	Eng	189				Furnished
287GSFJP-*5 (22)	265 C	Eng	229				Furnished	287GSFJP-*5 (22)	265 C	Eng	229				Furnished
287GSFJP-*8 (22)	265 C	Eng	210				Furnished	287GSFJP-*8 (22)	265 C	Eng	210				Furnished
877XAFJP-*5 (6)	591 C	Eng	116				Furnished	877XAFJP-*3 (6)	591 C	Eng	116				Furnished
877XBFJP-*5 (7)	552 C	Eng	124				Furnished	877XBFJP-*3 (7)	552 C	Eng	124				Furnished
877XCFJP-*5 (8)	515 C	Eng	133				Furnished	877XCFJP-*3 (8)	515 C	Eng	133				Furnished
877XDFJP-*5 (9)	482 C	Eng	142				Furnished	877XDFJP-*3 (9)	482 C	Eng	142				Furnished
877XEFJP-*5 (10)	425 C	Eng	161				Furnished	877XEFJP-*3 (10)	425 C	Eng	161				Furnished
877XFFJP-*5 (11)	376 C	Eng	182				Furnished	877XFFJP-*3 (11)	376 C	Eng	182				Furnished
877XGFJP-*5 (12)	332 C	Eng	207				Furnished	877XGFJP-*3 (12)	332 C	Eng	207				Furnished

Continued on Next Page

† I = Intermittent Torque Only - De-rate Torque Rating 30% for Continuous Duty.

C = Continuous or Intermittent Torque - No need to De-Rate Torque Rating.

IMPORTANT: Refer to the back of this transmission section and read all notes associated with this application page. Some notes may affect the proper PTO selection.

CAUTION: Chelsea Recommends the Power Take-Off (PTO) installation on the 3000/4000 Series Transmissions to utilize a Vehicle Interface Module, or Chassis Manufacturer's equivalent controller to incorporate all the PTO control features available, this includes the "PTO Request" and "PTO Enable Output" feature. The "PTO Enable" circuit signals the Transmission Control Module (TCM) to maintain line pressure to the PTO. Failure to provide this signal may not be sufficient to the PTO. This may cause damage to the PTO and /or Transmission. Please see the Allison Transmission website and individual chassis manufacturer for installation details.

CAUTION: The torque values given for specific application pages may be limited to the rated torque of the Allison transmission.

- (1) Input Gear Part No. 5-P-1173
- (2) Input Gear Part No. 5-P-1225
- (3) Input Gear Part No. 5-P-1293
- (4) Input Gear Part No. 5-P-1350
- (5) Input Gear Part No. 5-P-1351
- (6) Input Gear Part No. 5-P-1428-11X

- (7) Input Gear Part No. 5-P-1428-12X
- (8) Input Gear Part No. 5-P-1428-3X
- (9) Input Gear Part No. 5-P-1428-4X
- (10) Input Gear Part No. 5-P-1428-5X
- (11) Input Gear Part No. 5-P-1428-6X
- (12) Input Gear Part No. 5-P-1428-7X

- (15) Input Gear Part No. 5-P-1491-1X
- (16) Input Gear Part No. 5-P-1491-2X
- (17) Input Gear Part No. 5-P-1491-3X
- (18) Input Gear Part No. 5-P-1491-4X
- (19) Input Gear Part No. 5-P-1491-5X
- (20) Input Gear Part No. 5-P-1491-6X

- (21) Input Gear Part No. 5-P-1491-7X
- (22) Input Gear Part No. 5-P-1491-8X
- (23) Input Gear Part No. 5-P-912
- (24) Input Gear Part No. 5-P-913
- (25) Input Gear Part No. 5-P-914
- (26) Input Gear Part No. 5-P-915

4000 (4000 Family w/ Retarder)

LEFT SIDE ONLY

TOP SIDE ONLY

TRANSMISSION GEAR DATA:

L.S. 10-BOLT Opening Gear FORWARD of Centerline
97 Teeth - L.H. HELIX

PITCH LINE TO APERTURE FACE:

1.7799" (45.2100MM)

TRANSMISSION GEAR DATA:

TOP 10-BOLT Opening Gear FORWARD of Centerline
97 Teeth - L.H. HELIX

PITCH LINE TO APERTURE FACE:

1.7799" (45.2100MM)

CAUTION: Application Approval Required for PTO Output Shaft Speeds Above 2500 RPM

PTO Model	Torq l / C †	Dir Rot	Engine %		Filler Block	Adapter Assy	Stud Kit	PTO Model	Torq l / C †	Dir Rot	Engine %		Filler Block	Adapter Assy	Stud Kit
			Fwd	Rev							Fwd	Rev			

ONE SPEED - TWO GEAR - CONSTANT MESH

877XHFJP-*5 (13)	312 C	Eng	220				Furnished	877XHFJP-*3 (13)	312 C	Eng	220				Furnished
877XJFJP-*5 (14)	293 C	Eng	234				Furnished	877XJFJP-*3 (14)	293 C	Eng	234				Furnished

ONE SPEED - TWO GEAR - POWERSHIFT (HYDRAULIC)

280GBFJP-*5 (15)	300 C	Eng	85				Furnished	280GBFJP-*5 (15)	300 C	Eng	85				Furnished
280GBFJP-*8 (15)	300 C	Eng	81				Furnished	280GBFJP-*8 (15)	300 C	Eng	81				Furnished
280GCFJP-*5 (16)	390 C	Eng	103				Furnished	280GCFJP-*5 (16)	390 C	Eng	103				Furnished
280GCFJP-*8 (16)	390 C	Eng	97				Furnished	280GCFJP-*8 (16)	390 C	Eng	97				Furnished
280GDFJP-*5 (17)	390 C	Eng	123				Furnished	280GDFJP-*5 (17)	390 C	Eng	123				Furnished
280GDFJP-*8 (17)	390 C	Eng	116				Furnished	280GDFJP-*8 (17)	390 C	Eng	116				Furnished
280GGFJP-*5 (18)	360 C	Eng	147				Furnished	280GGFJP-*5 (18)	360 C	Eng	147				Furnished
280GGFJP-*8 (18)	360 C	Eng	137				Furnished	280GGFJP-*8 (18)	360 C	Eng	137				Furnished
280GKFJP-*5 (19)	340 C	Eng	164				Furnished	280GKFJP-*5 (19)	340 C	Eng	164				Furnished
280GMFJP-*5 (20)	318 C	Eng	184				Furnished	280GMFJP-*5 (20)	318 C	Eng	184				Furnished
280GMFJP-*8 (20)	318 C	Eng	170				Furnished	280GMFJP-*8 (20)	318 C	Eng	170				Furnished
280GPFJP-*5 (21)	290 C	Eng	205				Furnished	280GPFJP-*5 (21)	290 C	Eng	205				Furnished
280GPFJP-*8 (21)	290 C	Eng	189				Furnished	280GPFJP-*8 (21)	290 C	Eng	189				Furnished
280GSFJP-*5 (22)	265 C	Eng	229				Furnished	280GSFJP-*5 (22)	265 C	Eng	229				Furnished
280GSFJP-*8 (22)	265 C	Eng	210				Furnished	280GSFJP-*8 (22)	265 C	Eng	210				Furnished
870XAFJP-*5 (6)	591 C	Eng	116				Furnished	870XAFJP-*3 (6)	591 C	Eng	116				Furnished
870XBFJP-*5 (7)	552 C	Eng	124				Furnished	870XBFJP-*3 (7)	552 C	Eng	124				Furnished
870XCFJP-*5 (8)	515 C	Eng	133				Furnished	870XCFJP-*3 (8)	515 C	Eng	133				Furnished
870XDFJP-*5 (9)	482 C	Eng	142				Furnished	870XDFJP-*3 (9)	482 C	Eng	142				Furnished
870XEFJP-*5 (10)	425 C	Eng	161				Furnished	870XEFJP-*3 (10)	425 C	Eng	161				Furnished
870XFFJP-*5 (11)	376 C	Eng	182				Furnished	870XFFJP-*3 (11)	376 C	Eng	182				Furnished
870XGFJP-*5 (12)	332 C	Eng	207				Furnished	870XGFJP-*3 (12)	332 C	Eng	207				Furnished
870XHFJP-*5 (13)	312 C	Eng	220				Furnished	870XHFJP-*3 (13)	312 C	Eng	220				Furnished
870XJFJP-*5 (14)	293 C	Eng	234				Furnished	870XJFJP-*3 (14)	293 C	Eng	234				Furnished

ONE SPEED - POWERSHIFT (HYDRAULIC) EXTENDED SHAFT

870LAFJW-*5 (6)	591	Eng	116				Furnished	890KAFJW-*5 (6)	591 C	Eng	116				Furnished
870LBFJW-*5 (7)	552	Eng	124				Furnished	890KBFJW-*5 (7)	552 C	Eng	124				Furnished

Continued on Next Page

† I = Intermittent Torque Only - De-rate Torque Rating 30% for Continuous Duty.

C = Continuous or Intermittent Torque - No need to De-Rate Torque Rating.

IMPORTANT: Refer to the back of this transmission section and read all notes associated with this application page. Some notes may affect the proper PTO selection.

CAUTION: Chelsea Recommends the Power Take-Off (PTO) installation on the 3000/4000 Series Transmissions to utilize a Vehicle Interface Module, or Chassis Manufacturer's equivalent controller to incorporate all the PTO control features available, this includes the "PTO Request" and "PTO Enable Output" feature. The "PTO Enable" circuit signals the Transmission Control Module (TCM) to maintain line pressure to the PTO. Failure to provide this signal may not be sufficient to the PTO. This may cause damage to the PTO and /or Transmission. Please see the Allison Transmission website and individual chassis manufacturer for installation details.

CAUTION: The torque values given for specific application pages may be limited to the rated torque of the Allison transmission.

- | | | |
|--------------------------------------|--------------------------------------|--------------------------------------|
| (6) Input Gear Part No. 5-P-1428-11X | (12) Input Gear Part No. 5-P-1428-7X | (18) Input Gear Part No. 5-P-1491-4X |
| (7) Input Gear Part No. 5-P-1428-12X | (13) Input Gear Part No. 5-P-1428-8X | (19) Input Gear Part No. 5-P-1491-5X |
| (8) Input Gear Part No. 5-P-1428-3X | (14) Input Gear Part No. 5-P-1428-9X | (20) Input Gear Part No. 5-P-1491-6X |
| (9) Input Gear Part No. 5-P-1428-4X | (15) Input Gear Part No. 5-P-1491-1X | (21) Input Gear Part No. 5-P-1491-7X |
| (10) Input Gear Part No. 5-P-1428-5X | (16) Input Gear Part No. 5-P-1491-2X | (22) Input Gear Part No. 5-P-1491-8X |
| (11) Input Gear Part No. 5-P-1428-6X | (17) Input Gear Part No. 5-P-1491-3X | |

CHELSEA®

ALLISON

ALL-14R

4000 (4000 Family w/ Retarder)

LEFT SIDE ONLY

TOP SIDE ONLY

TRANSMISSION GEAR DATA:

L.S. 10-BOLT Opening Gear FORWARD of Centerline
97 Teeth - L.H. HELIX

PITCH LINE TO APERTURE FACE:

1.7799" (45.2100MM)

TRANSMISSION GEAR DATA:

TOP 10-BOLT Opening Gear FORWARD of Centerline
97 Teeth - L.H. HELIX

PITCH LINE TO APERTURE FACE:

1.7799" (45.2100MM)

CAUTION: Application Approval Required for PTO Output Shaft Speeds Above 2500 RPM

PTO Model	Torq I / C †	Dir Rot	Engine %		Filler Block	Adapter Assy	Stud Kit	PTO Model	Torq I / C †	Dir Rot	Engine %		Filler Block	Adapter Assy	Stud Kit
			Fwd	Rev							Fwd	Rev			

ONE SPEED - POWERSHIFT (HYDRAULIC) EXTENDED SHAFT

870LCFJW-*5 (8)	515	Eng	133				Furnished	890KCFJW-*5 (8)	515 C	Eng	133				Furnished
870LDFJW-*5 (9)	482	Eng	142				Furnished	890KDFJW-*5 (9)	482 C	Eng	142				Furnished
870LEFJW-*5 (10)	425	Eng	161				Furnished	890KEFJW-*5 (10)	425 C	Eng	161				Furnished
870LFFJW-*5 (11)	376	Eng	182				Furnished	890KFFJW-*5 (11)	376 C	Eng	182				Furnished
890JAFJW-*3 (6)	591 C	Eng	116				Furnished								
890JBFJW-*3 (7)	552 C	Eng	124				Furnished								
890JCFJW-*3 (8)	515 C	Eng	133				Furnished								
890JDFJW-*3 (9)	482 C	Eng	142				Furnished								
890JEFJW-*3 (10)	425 C	Eng	161				Furnished								
890JFFJW-*3 (11)	376 C	Eng	182				Furnished								
890PAFJW-*5 (6)	591 C	Eng	116				Furnished								
890PBFJW-*5 (7)	552 C	Eng	124				Furnished								
890PCFJW-*5 (8)	515 C	Eng	133				Furnished								
890PDFJW-*5 (9)	482 C	Eng	142				Furnished								
890PEFJW-*5 (10)	425 C	Eng	161				Furnished								
890PFFJW-*5 (11)	376 C	Eng	182				Furnished								

ONE SPEED - CONSTANT MESH EXTENDED SHAFT

877LAFJW-*5 (6)	591	Eng	116				Furnished	897KAFJW-*5 (6)	591 C	Eng	116				Furnished
877LBFJW-*5 (7)	552	Eng	124				Furnished	897KBFJW-*5 (7)	552 C	Eng	124				Furnished
877LCFJW-*5 (8)	515	Eng	133				Furnished	897KCFJW-*5 (8)	515 C	Eng	133				Furnished
877LDFJW-*5 (9)	482	Eng	142				Furnished	897KDFJW-*5 (9)	482 C	Eng	142				Furnished
877LEFJW-*5 (10)	425	Eng	161				Furnished	897KEFJW-*5 (10)	425 C	Eng	161				Furnished
877LFFJW-*5 (11)	376	Eng	182				Furnished	897KFFJW-*5 (11)	376 C	Eng	182				Furnished
897JAFJW-*3 (6)	591 C	Eng	116				Furnished								
897JBFJW-*3 (7)	552 C	Eng	124				Furnished								
897JCFJW-*3 (8)	515 C	Eng	133				Furnished								
897JDFJW-*3 (9)	482 C	Eng	142				Furnished								
897JEFJW-*3 (10)	425 C	Eng	161				Furnished								
897JFFJW-*3 (11)	376 C	Eng	182				Furnished								
897PAFJW-*5 (6)	591 C	Eng	116				Furnished								
897PBFJW-*5 (7)	552 C	Eng	124				Furnished								

Continued on Next Page

† I = Intermittent Torque Only - De-rate Torque Rating 30% for Continuous Duty.

C = Continuous or Intermittent Torque - No need to De-Rate Torque Rating.

IMPORTANT: Refer to the back of this transmission section and read all notes associated with this application page. Some notes may affect the proper PTO selection.

CAUTION: Chelsea Recommends the Power Take-Off (PTO) installation on the 3000/4000 Series Transmissions to utilize a Vehicle Interface Module, or Chassis Manufacturer's equivalent controller to incorporate all the PTO control features available, this includes the "PTO Request" and "PTO Enable Output" feature. The "PTO Enable" circuit signals the Transmission Control Module (TCM) to maintain line pressure to the PTO. Failure to provide this signal may not be sufficient to the PTO. This may cause damage to the PTO and /or Transmission. Please see the Allison Transmission website and individual chassis manufacturer for installation details.

CAUTION: The torque values given for specific application pages may be limited to the rated torque of the Allison transmission.

(6) Input Gear Part No. 5-P-1428-11X
 (7) Input Gear Part No. 5-P-1428-12X
 (8) Input Gear Part No. 5-P-1428-3X
 (9) Input Gear Part No. 5-P-1428-4X
 (10) Input Gear Part No. 5-P-1428-5X
 (11) Input Gear Part No. 5-P-1428-6X

ALL-14R

ALLISON

CHELSEA®

4000 (4000 Family w/ Retarder)

LEFT SIDE ONLY

TOP SIDE ONLY

TRANSMISSION GEAR DATA:L.S. 10-BOLT Opening Gear FORWARD of Centerline
97 Teeth - L.H. HELIX**PITCH LINE TO APERTURE FACE:**

1.7799" (45.2100MM)

TRANSMISSION GEAR DATA:TOP 10-BOLT Opening Gear FORWARD of Centerline
97 Teeth - L.H. HELIX**PITCH LINE TO APERTURE FACE:**

1.7799" (45.2100MM)

CAUTION: Application Approval Required for PTO Output Shaft Speeds Above 2500 RPM

PTO Model	Torq	Dir Rot	Engine %		Filler Block	Adapter Assy	Stud Kit	PTO Model	Torq	Dir Rot	Engine %		Filler Block	Adapter Assy	Stud Kit
	I / C †		Fwd	Rev					I / C †		Fwd	Rev			

ONE SPEED - CONSTANT MESH EXTENDED SHAFT

897PCFJW-*5 (8)	515 C	Eng	133				Furnished
897PDFJW-*5 (9)	482 C	Eng	142				Furnished
897PEFJW-*5 (10)	425 C	Eng	161				Furnished
897PFJW-*5 (11)	376 C	Eng	182				Furnished

† I = Intermittent Torque Only - De-rate Torque Rating 30% for Continuous Duty.

C = Continuous or Intermittent Torque - No need to De-Rate Torque Rating.

IMPORTANT: Refer to the back of this transmission section and read all notes associated with this application page. Some notes may affect the proper PTO selection.

CAUTION: Chelsea Recommends the Power Take-Off (PTO) installation on the 3000/4000 Series Transmissions to utilize a Vehicle Interface Module, or Chassis Manufacturer's equivalent controller to incorporate all the PTO control features available, this includes the "PTO Request" and "PTO Enable Output" feature. The "PTO Enable" circuit signals the Transmission Control Module (TCM) to maintain line pressure to the PTO. Failure to provide this signal may not be sufficient to the PTO. This may cause damage to the PTO and /or Transmission. Please see the Allison Transmission website and individual chassis manufacturer for installation details.

CAUTION: The torque values given for specific application pages may be limited to the rated torque of the Allison transmission.

(8) Input Gear Part No. 5-P-1428-3X
 (9) Input Gear Part No. 5-P-1428-4X
 (10) Input Gear Part No. 5-P-1428-5X
 (11) Input Gear Part No. 5-P-1428-6X

CHELSEA®

ALLISON

ALL-15

1000 1000 EVS 1000 MH 1000 RDS 1350 (Available in 4,5 & 6 Speed) 1350 EVS (Available in 4,5 & 6 Speed) 1350 MH (Available in 4,5 & 6 Speed) 350 RDS (Available in 4,5 & 6 Speed)	1350 SP (Available in 4,5 & 6 Speed) 2000 2100 EVS 2100 MH 2100 RDS 2200 EVS 2200 MH 2200 RDS	2300 RDS 2400 2500 EVS 2500 MH 2500 RDS
---	--	---

LEFT SIDE ONLY

RIGHT SIDE ONLY

TRANSMISSION GEAR DATA:

L.S. 06-BOLT Opening Gear FORWARD of Centerline
64 Teeth - SPUR

PITCH LINE TO APERTURE FACE:

1.0080" (25.6000MM)

TRANSMISSION GEAR DATA:

R.S. 06-BOLT Opening Gear FORWARD of Centerline
64 Teeth - SPUR

PITCH LINE TO APERTURE FACE:

1.0080" (25.6032MM)

CAUTION: Application Approval Required for PTO Output Shaft Speeds Above 2500 RPM

PTO Model	Torq I / C †	Dir Rot	Engine %		Filler Block	Adapter Assy	Stud Kit	PTO Model	Torq I / C †	Dir Rot	Engine %		Filler Block	Adapter Assy	Stud Kit
			Fwd	Rev							Fwd	Rev			

ONE SPEED - TWO GEAR - MECHANICAL SHIFT

442GBHVP-*5 (3)	215 I	Eng	96				Furnished	442GBHVP-*3 (3)	215 I	Eng	96				Furnished
442GBHVX-*5 (3)	150 I	Eng	96				Furnished	442GBHVX-*3 (3)	150 I	Eng	96				Furnished
442GFHVP-*5 (2)	165 I	Eng	151				Furnished	442GFHVP-*3 (2)	165 I	Eng	151				Furnished

ONE SPEED - TWO GEAR POWERSHIFT (AIR OR HYDRAULIC)

272GAHVP-*5 (5)	294 C	Eng	85				Furnished	272GAHVP-*3 (5)	294 C	Eng	85				Furnished
272GBHVP-*5 (6)	240 C	Eng	104				Furnished	272GBHVP-*3 (6)	240 C	Eng	104				Furnished
272GCHVP-*5 (7)	198 C	Eng	126				Furnished	272GCHVP-*3 (7)	198 C	Eng	126				Furnished
272GDHVP-*5 (8)	166 C	Eng	151				Furnished	272GDHVP-*3 (8)	166 C	Eng	151				Furnished

ONE SPEED - POWERSHIFT LOW PROFILE (AIR OR HYDRAULIC)

272NAHVP-*3 (5)	294 C	Eng	85				Furnished	272NAHVP-*5 (5)	294 C	Eng	85				Furnished
272NBHVP-*3 (6)	240 C	Eng	104				Furnished	272NBHVP-*5 (6)	240 C	Eng	104				Furnished
272NCHVP-*3 (7)	198 C	Eng	126				Furnished	272NCHVP-*5 (7)	198 C	Eng	126				Furnished
272NDHVP-*3 (8)	166 C	Eng	151				Furnished	272NDHVP-*5 (8)	166 C	Eng	151				Furnished

ONE SPEED - TWO GEAR - POWERSHIFT (HYDRAULIC)

252GDHVP-*5 (1)	120 I	Eng	122				Furnished	252GDHVX-*5 (1)	120 I	Eng	122				Furnished
252GMHVP-*5 (4)	50 I	Eng	178				Furnished	252GMHVX-*5 (4)	50 I	Eng	178				Furnished

GEARED ADAPTERS

626GHVX-4HV (2)	250 I	Opp		7-A-140(P)(9)		Furnished	626GHVX-3HV (2)	250 I	Opp		7-A-140(P)(9)		Furnished
630GHVX-4HV (2)	250 I	Opp		7-A-140(P)(9)		Furnished	630GHVX-3HV (2)	250 I	Opp		7-A-140(P)(9)		Furnished
645GHVX-4HV (2)	250 I	Opp		7-A-140(P)(9)		Furnished	645GHVX-3HV (2)	250 I	Opp		7-A-140(P)(9)		Furnished

† I = Intermittent Torque Only - De-rate Torque Rating 30% for Continuous Duty.

C = Continuous or Intermittent Torque - No need to De-Rate Torque Rating.

IMPORTANT: Refer to the back of this transmission section and read all notes associated with this application page. Some notes may affect the proper PTO selection.

CAUTION: Chelsea Recommends the Power Take-Off (PTO) installation on the 3000/4000 Series Transmissions to utilize a Vehicle Interface Module, or Chassis Manufacturer's equivalent controller to incorporate all the PTO control features available, this includes the "PTO Request" and "PTO Enable Output" feature. The "PTO Enable" circuit signals the Transmission Control Module (TCM) to maintain line pressure to the PTO. Failure to provide this signal may not be sufficient to the PTO. This may cause damage to the PTO and /or Transmission. Please see the Allison Transmission website and individual chassis manufacturer for installation details.

- (1) Input Gear Part No. 5-P-1294
 (2) Input Gear Part No. 5-P-1300
 (3) Input Gear Part No. 5-P-1358
 (4) Input Gear Part No. 5-P-1386
 (5) Input Gear Part No. 5-P-1516-1X
 (6) Input Gear Part No. 5-P-1516-2X

- (7) Input Gear Part No. 5-P-1516-3X
 (8) Input Gear Part No. 5-P-1516-4X
 (9) Filler block furnished with PTO

ALL-16

ALLISON

CHELSEA®

MD-3066P (Europe Only)	3500 SP (Side/Top PTO Provision)
3000 RDS (Side/Top PTO Provision)	3000 (International - Side/Top PTO Provision)
3500 RDS (Side/Top PTO Provision)	3200 (International - Side/Top PTO Provision)
3500 ORS (Side/Top PTO Provision)	3500 (International - Side/Top PTO Provision)
3200 ORS (Side/Top PTO Provision)	
3000 ORS (Side/Top PTO Provision)	
3000 SP (Side/Top PTO Provision)	
3200 SP (Side/Top PTO Provision)	

LEFT SIDE ONLY

TOP SIDE ONLY

TRANSMISSION GEAR DATA:

L.S. 10-BOLT Opening Gear FORWARD of Centerline
83 Teeth - L.H. HELIX

PITCH LINE TO APERTURE FACE:

1.7800" (45.2100MM)

TRANSMISSION GEAR DATA:

TOP 10-BOLT Opening Gear FORWARD of Centerline
83 Teeth - L.H. HELIX

PITCH LINE TO APERTURE FACE:

1.7800" (45.2100MM)

CAUTION: Application Approval Required for PTO Output Shaft Speeds Above 2500 RPM

PTO Model	Torq I / C †	Dir Rot	Engine %		Filler Block	Adapter Assy	Stud Kit	PTO Model	Torq I / C †	Dir Rot	Engine %		Filler Block	Adapter Assy	Stud Kit
			Fwd	Rev							Fwd	Rev			

ONE SPEED - TWO GEAR - CONSTANT MESH

267SBFJP-5 (4)	402 I	Eng	88				Furnished	267SBFJP-3 (4)	402 I	Eng	88				Furnished
267SDFJP-5 (3)	390 I	Eng	106				Furnished	267SDFJP-3 (3)	390 I	Eng	106				Furnished
267SGFJP-5 (2)	360 I	Eng	126				Furnished	267SGFJP-3 (2)	360 I	Eng	126				Furnished
267SMFJP-5 (5)	309 I	Eng	157				Furnished	267SMFJP-3 (5)	309 I	Eng	157				Furnished
267SSFJP-5 (1)	247 I	Eng	196				Furnished	267SSFJP-3 (1)	247 I	Eng	196				Furnished
267XBFJP-5 (25)	335 I	Eng	88				Furnished	267XBFJP-3 (25)	335 I	Eng	88				Furnished
267XDFJP-5 (26)	325 I	Eng	106				Furnished	267XDFJP-3 (26)	325 I	Eng	106				Furnished
267XGFJP-5 (27)	300 I	Eng	126				Furnished	267XGFJP-3 (27)	300 I	Eng	126				Furnished
267XMFJP-5 (28)	265 I	Eng	157				Furnished	267XMFJP-3 (28)	265 I	Eng	157				Furnished
267XSFJP-5 (1)	247 I	Eng	196				Furnished	267XSFJP-3 (1)	247 I	Eng	196				Furnished
287GBFJP-5 (17)	300 C	Eng	73				Furnished	287GBFJP-3 (17)	300 C	Eng	73				Furnished
287GBFJP-8 (17)	300 C	Eng	69				Furnished	287GBFJP-8 (17)	300 C	Eng	69				Furnished
287GCFJP-5 (18)	390 C	Eng	88				Furnished	287GCFJP-3 (18)	390 C	Eng	88				Furnished
287GCFJP-8 (18)	390 C	Eng	83				Furnished	287GCFJP-8 (18)	390 C	Eng	83				Furnished
287GDFJP-5 (19)	390 C	Eng	87				Furnished	287GDFJP-3 (19)	390 C	Eng	87				Furnished
287GDFJP-8 (19)	390 C	Eng	99				Furnished	287GDFJP-8 (19)	390 C	Eng	99				Furnished
287GGFJP-5 (20)	360 C	Eng	126				Furnished	287GGFJP-3 (20)	360 C	Eng	126				Furnished
287GGFJP-8 (20)	360 C	Eng	117				Furnished	287GGFJP-8 (20)	360 C	Eng	117				Furnished
287GKFJP-5 (21)	340 C	Eng	140				Furnished	287GKFJP-3 (21)	340 C	Eng	140				Furnished
287GMFJP-5 (22)	309 C	Eng	157				Furnished	287GMFJP-3 (22)	309 C	Eng	157				Furnished
287GMFJP-8 (22)	318 C	Eng	145				Furnished	287GMFJP-8 (22)	318 C	Eng	145				Furnished
287GPFJP-5 (23)	275 C	Eng	175				Furnished	287GPFJP-3 (23)	275 C	Eng	175				Furnished
287GPFJP-8 (23)	290 C	Eng	162				Furnished	287GPFJP-8 (23)	290 C	Eng	162				Furnished
287GSFJP-5 (24)	247 C	Eng	196				Furnished	287GSFJP-3 (24)	247 C	Eng	196				Furnished
287GSFJP-8 (24)	265 C	Eng	180				Furnished	287GSFJP-8 (24)	265 C	Eng	180				Furnished
287GTFJP-8 (16)	230 C	Eng	211				Furnished	287GTFJP-8 (16)	230 C	Eng	211				Furnished
877XAFJP-5 (7)	485 C	Eng	100				Furnished	877XAFJP-3 (7)	485 C	Eng	100				Furnished
877XBFJP-5 (8)	458 C	Eng	106				Furnished	877XBFJP-3 (8)	458 C	Eng	106				Furnished
877XCFJP-5 (9)	425 C	Eng	114				Furnished	877XCFJP-3 (9)	425 C	Eng	114				Furnished
877XDFJP-5 (10)	401 C	Eng	121				Furnished	877XDFJP-3 (10)	401 C	Eng	121				Furnished
877XEFJP-5 (11)	351 C	Eng	138				Furnished	877XEFJP-3 (11)	351 C	Eng	138				Furnished
877XFFJP-5 (12)	311C	Eng	156				Furnished	877XFFJP-3 (12)	311C	Eng	156				Furnished

Continued on Next Page

† I = Intermittent Torque Only - De-rate Torque Rating 30% for Continuous Duty.

C = Continuous or Intermittent Torque - No need to De-Rate Torque Rating.

IMPORTANT: Refer to the back of this transmission section and read all notes associated with this application page. Some notes may affect the proper PTO selection.

CAUTION: Chelsea Recommends the Power Take-Off (PTO) installation on the 3000/4000 Series Transmissions to utilize a Vehicle Interface Module, or Chassis Manufacturer's equivalent controller to incorporate all the PTO control features available, this includes the "PTO Request" and "PTO Enable Output" feature. The "PTO Enable" circuit signals the Transmission Control Module (TCM) to maintain line pressure to the PTO. Failure to provide this signal may not be sufficient to the PTO. This may cause damage to the PTO and /or Transmission. Please see the Allison Transmission website and individual chassis manufacturer for installation details.

CAUTION: The torque values given for specific application pages may be limited to the rated torque of the Allison transmission.

- | | | | |
|--------------------------------------|---------------------------------------|--------------------------------------|--------------------------------------|
| (1) Input Gear Part No. 5-P-1173 | (8) Input Gear Part No. 5-P-1428-12X | (17) Input Gear Part No. 5-P-1491-1X | (23) Input Gear Part No. 5-P-1491-7X |
| (2) Input Gear Part No. 5-P-1225 | (9) Input Gear Part No. 5-P-1428-3X | (18) Input Gear Part No. 5-P-1491-2X | (24) Input Gear Part No. 5-P-1491-8X |
| (3) Input Gear Part No. 5-P-1293 | (10) Input Gear Part No. 5-P-1428-4X | (19) Input Gear Part No. 5-P-1491-3X | (25) Input Gear Part No. 5-P-912 |
| (4) Input Gear Part No. 5-P-1350 | (11) Input Gear Part No. 5-P-1428-5X | (20) Input Gear Part No. 5-P-1491-4X | (26) Input Gear Part No. 5-P-913 |
| (5) Input Gear Part No. 5-P-1351 | (12) Input Gear Part No. 5-P-1428-6X | (21) Input Gear Part No. 5-P-1491-5X | (27) Input Gear Part No. 5-P-914 |
| (7) Input Gear Part No. 5-P-1428-11X | (16) Input Gear Part No. 5-P-1491-10X | (22) Input Gear Part No. 5-P-1491-6X | (28) Input Gear Part No. 5-P-915 |

CHELSEA®

ALLISON

ALL-16

MD-3066P (Europe Only)	3500 SP (Side/Top PTO Provision)
3000 RDS (Side/Top PTO Provision)	3000 (International - Side/Top PTO Provision)
3500 RDS (Side/Top PTO Provision)	3200 (International - Side/Top PTO Provision)
3500 ORS (Side/Top PTO Provision)	3500 (International - Side/Top PTO Provision)
3200 ORS (Side/Top PTO Provision)	
3000 ORS (Side/Top PTO Provision)	
3000 SP (Side/Top PTO Provision)	
3200 SP (Side/Top PTO Provision)	

LEFT SIDE ONLY

TOP SIDE ONLY

TRANSMISSION GEAR DATA:

L.S. 10-BOLT Opening Gear FORWARD of Centerline
83 Teeth - L.H. HELIX

PITCH LINE TO APERTURE FACE:

1.7800" (45.2100MM)

TRANSMISSION GEAR DATA:

TOP 10-BOLT Opening Gear FORWARD of Centerline
83 Teeth - L.H. HELIX

PITCH LINE TO APERTURE FACE:

1.7800" (45.2100MM)

CAUTION: Application Approval Required for PTO Output Shaft Speeds Above 2500 RPM

PTO Model	Torq I / C †	Dir Rot	Engine %		Filler Block	Adapter Assy	Stud Kit	PTO Model	Torq I / C †	Dir Rot	Engine %		Filler Block	Adapter Assy	Stud Kit
			Fwd	Rev							Fwd	Rev			

ONE SPEED - TWO GEAR - CONSTANT MESH

877XGFJP-*5 (13)	274 C	Eng	177				Furnished	877XGFJP-*3 (13)	274 C	Eng	177				Furnished
877XHFJP-*5 (14)	258 C	Eng	188				Furnished	877XHFJP-*3 (14)	258 C	Eng	188				Furnished
877XJFJP-*5 (15)	242 C	Eng	200				Furnished	877XJFJP-*3 (15)	242 C	Eng	200				Furnished
877XKFJP-*5 (6)	292 C	Eng	166				Furnished	877XKFJP-*3 (6)	292 C	Eng	166				Furnished

ONE SPEED - TWO GEAR - POWERSHIFT (HYDRAULIC)

280GBFJP-*5 (17)	300 C	Eng	73				Furnished	280GBFJP-*3 (17)	300 C	Eng	73				Furnished
280GBFJP-*8 (17)	300 C	Eng	69				Furnished	280GBFJP-*8 (17)	300 C	Eng	69				Furnished
280GCFJP-*5 (18)	390 C	Eng	88				Furnished	280GCFJP-*3 (18)	390 C	Eng	88				Furnished
280GCFJP-*8 (18)	390 C	Eng	83				Furnished	280GCFJP-*8 (18)	390 C	Eng	83				Furnished
280GDFJP-*5 (19)	390 C	Eng	106				Furnished	280GDFJP-*3 (19)	390 C	Eng	106				Furnished
280GDFJP-*8 (19)	390 C	Eng	99				Furnished	280GDFJP-*8 (19)	390 C	Eng	99				Furnished
280GGFJP-*5 (20)	360 C	Eng	126				Furnished	280GGFJP-*3 (20)	360 C	Eng	126				Furnished
280GGFJP-*8 (20)	360 C	Eng	117				Furnished	280GGFJP-*8 (20)	360 C	Eng	117				Furnished
280GKFJP-*5 (21)	340 C	Eng	140				Furnished	280GKFJP-*3 (21)	340 C	Eng	140				Furnished
280GMFJP-*5 (22)	309 C	Eng	157				Furnished	280GMFJP-*3 (22)	309 C	Eng	157				Furnished
280GMFJP-*8 (22)	318 C	Eng	145				Furnished	280GMFJP-*8 (22)	318 C	Eng	145				Furnished
280GPFJP-*5 (23)	275 C	Eng	175				Furnished	280GPFJP-*3 (23)	275 C	Eng	175				Furnished
280GPFJP-*8 (23)	290 C	Eng	162				Furnished	280GPFJP-*8 (23)	290 C	Eng	162				Furnished
280GSFJP-*5 (24)	247 C	Eng	196				Furnished	280GSFJP-*3 (24)	247 C	Eng	196				Furnished
280GSFJP-*8 (24)	265 C	Eng	180				Furnished	280GSFJP-*8 (24)	265 C	Eng	180				Furnished
280GTFJP-*8 (16)	230 C	Eng	211				Furnished	280GTFJP-*8 (16)	230 C	Eng	211				Furnished
870XAFJP-*5 (7)	485 C	Eng	100				Furnished	870XAFJP-*3 (7)	485 C	Eng	100				Furnished
870XBFJP-*5 (8)	458 C	Eng	106				Furnished	870XBFJP-*3 (8)	458 C	Eng	106				Furnished
870XCFJP-*5 (9)	425 C	Eng	114				Furnished	870XCFJP-*3 (9)	425 C	Eng	114				Furnished
870XDFJP-*5 (10)	401 C	Eng	121				Furnished	870XDFJP-*3 (10)	401 C	Eng	121				Furnished
870XEFJP-*5 (11)	351 C	Eng	138				Furnished	870XEFJP-*3 (11)	351 C	Eng	138				Furnished
870XFFJP-*5 (12)	311 C	Eng	156				Furnished	870XFFJP-*3 (12)	311 C	Eng	156				Furnished
870XGFJP-*5 (13)	274 C	Eng	177				Furnished	870XGFJP-*3 (13)	274 C	Eng	177				Furnished
870XHFJP-*5 (14)	258 C	Eng	188				Furnished	870XHFJP-*3 (14)	258 C	Eng	188				Furnished
870XJFJP-*5 (15)	242 C	Eng	200				Furnished	870XJFJP-*3 (15)	242 C	Eng	200				Furnished

Continued on Next Page

† I = Intermittent Torque Only - De-rate Torque Rating 30% for Continuous Duty.

C = Continuous or Intermittent Torque - No need to De-Rate Torque Rating.

IMPORTANT: Refer to the back of this transmission section and read all notes associated with this application page. Some notes may affect the proper PTO selection.

CAUTION: Chelsea Recommends the Power Take-Off (PTO) installation on the 3000/4000 Series Transmissions to utilize a Vehicle Interface Module, or Chassis Manufacturer's equivalent controller to incorporate all the PTO control features available, this includes the "PTO Request" and "PTO Enable Output" feature. The "PTO Enable" circuit signals the Transmission Control Module (TCM) to maintain line pressure to the PTO. Failure to provide this signal may not be sufficient to the PTO. This may cause damage to the PTO and /or Transmission. Please see the Allison Transmission website and individual chassis manufacturer for installation details.

CAUTION: The torque values given for specific application pages may be limited to the rated torque of the Allison transmission.

(6) Input Gear Part No. 5-P-1428-10X	(12) Input Gear Part No. 5-P-1428-6X	(18) Input Gear Part No. 5-P-1491-2X	(24) Input Gear Part No. 5-P-1491-8X
(7) Input Gear Part No. 5-P-1428-11X	(13) Input Gear Part No. 5-P-1428-7X	(19) Input Gear Part No. 5-P-1491-3X	
(8) Input Gear Part No. 5-P-1428-12X	(14) Input Gear Part No. 5-P-1428-8X	(20) Input Gear Part No. 5-P-1491-4X	
(9) Input Gear Part No. 5-P-1428-3X	(15) Input Gear Part No. 5-P-1428-9X	(21) Input Gear Part No. 5-P-1491-5X	
(10) Input Gear Part No. 5-P-1428-4X	(16) Input Gear Part No. 5-P-1491-10X	(22) Input Gear Part No. 5-P-1491-6X	
(11) Input Gear Part No. 5-P-1428-5X	(17) Input Gear Part No. 5-P-1491-1X	(23) Input Gear Part No. 5-P-1491-7X	

ALL-16

ALLISON

CHELSEA®

MD-3066P (Europe Only)	3500 SP (Side/Top PTO Provision)
3000 RDS (Side/Top PTO Provision)	3000 (International - Side/Top PTO Provision)
3500 RDS (Side/Top PTO Provision)	3200 (International - Side/Top PTO Provision)
3500 ORS (Side/Top PTO Provision)	3500 (International - Side/Top PTO Provision)
3200 ORS (Side/Top PTO Provision)	
3000 ORS (Side/Top PTO Provision)	
3000 SP (Side/Top PTO Provision)	
3200 SP (Side/Top PTO Provision)	

LEFT SIDE ONLY

TOP SIDE ONLY

TRANSMISSION GEAR DATA:

L.S. 10-BOLT Opening Gear FORWARD of Centerline
83 Teeth - L.H. HELIX

PITCH LINE TO APERTURE FACE:

1.7800" (45.2100MM)

TRANSMISSION GEAR DATA:

TOP 10-BOLT Opening Gear FORWARD of Centerline
83 Teeth - L.H. HELIX

PITCH LINE TO APERTURE FACE:

1.7800" (45.2100MM)

CAUTION: Application Approval Required for PTO Output Shaft Speeds Above 2500 RPM

PTO Model	Torq I / C †	Dir Rot	Engine %		Filler Block	Adapter Assy	Stud Kit	PTO Model	Torq I / C †	Dir Rot	Engine %		Filler Block	Adapter Assy	Stud Kit
			Fwd	Rev							Fwd	Rev			

ONE SPEED - POWERSHIFT (HYDRAULIC) EXTENDED SHAFT

870LAFJW-*5 (7)	485 C	Eng	100				Furnished	890TAFJW-*5 (7)	485 C	Eng	100				Furnished
870LBFJW-*5 (8)	458 C	Eng	106				Furnished	890TBFJW-*5 (8)	458 C	Eng	106				Furnished
870LCFJW-*5 (9)	425 C	Eng	114				Furnished	890TCFJW-*5 (9)	425 C	Eng	114				Furnished
870LDFJW-*5 (10)	401 C	Eng	121				Furnished	890TDFJW-*5 (10)	401 C	Eng	121				Furnished
870LEFJW-*5 (11)	351 C	Eng	138				Furnished	890TEFJW-*5 (11)	351 C	Eng	138				Furnished
870LFFJW-*5 (12)	311 C	Eng	156				Furnished	890TFFJW-*5 (12)	311 C	Eng	156				Furnished
870LGFJW-*5 (13)	274 C	Eng	177				Furnished	890TGFJW-*5 (13)	274 C	Eng	177				Furnished
870LHFJW-*5 (14)	258 C	Eng	188				Furnished	890THFJW-*5 (14)	258 C	Eng	188				Furnished
890EAFJW-*5 (7)	485 C	Eng	100				Furnished								
890EBFJW-*5 (8)	458 C	Eng	106				Furnished								
890ECFJW-*5 (9)	425 C	Eng	114				Furnished								
890EDFJW-*5 (10)	401 C	Eng	121				Furnished								
890EEFJW-*5 (11)	351 C	Eng	138				Furnished								
890EFFJW-*5 (12)	311 C	Eng	156				Furnished								
890EGFJW-*5 (13)	274 C	Eng	177				Furnished								
890EHFJW-*5 (14)	258 C	Eng	188				Furnished								

ONE SPEED - CONSTANT MESH EXTENDED SHAFT

877LAFJW-*5 (7)	485 C	Eng	100				Furnished	897TAFJW-*5 (7)	485 C	Eng	100				Furnished
877LBFJW-*5 (8)	458 C	Eng	106				Furnished	897TBFJW-*5 (8)	458 C	Eng	106				Furnished
877LCFJW-*5 (9)	425 C	Eng	114				Furnished	897TCFJW-*5 (9)	425 C	Eng	114				Furnished
877LDFJW-*5 (10)	401 C	Eng	121				Furnished	897TDFJW-*5 (10)	401 C	Eng	121				Furnished
877LEFJW-*5 (11)	351 C	Eng	138				Furnished	897TEFJW-*5 (11)	351 C	Eng	138				Furnished
877LFFJW-*5 (12)	311 C	Eng	156				Furnished	897TFFJW-*5 (12)	311 C	Eng	156				Furnished
877LGFJW-*5 (13)	274 C	Eng	177				Furnished	897TGFJW-*5 (13)	274 C	Eng	177				Furnished
877LHFJW-*5 (14)	258 C	Eng	188				Furnished	897THFJW-*5 (14)	258 C	Eng	188				Furnished
897EAFJW-*5 (7)	485 C	Eng	100				Furnished								
897EBFJW-*5 (8)	458 C	Eng	106				Furnished								
897ECFJW-*5 (9)	425 C	Eng	114				Furnished								
897EDFJW-*5 (10)	401 C	Eng	121				Furnished								
897EEFJW-*5 (11)	351 C	Eng	138				Furnished								
897EFFJW-*5 (12)	311 C	Eng	156				Furnished								

Continued on Next Page

† I = Intermittent Torque Only - De-rate Torque Rating 30% for Continuous Duty.

C = Continuous or Intermittent Torque - No need to De-Rate Torque Rating.

IMPORTANT: Refer to the back of this transmission section and read all notes associated with this application page. Some notes may affect the proper PTO selection.

CAUTION: Chelsea Recommends the Power Take-Off (PTO) installation on the 3000/4000 Series Transmissions to utilize a Vehicle Interface Module, or Chassis Manufacturer's equivalent controller to incorporate all the PTO control features available, this includes the "PTO Request" and "PTO Enable Output" feature. The "PTO Enable" circuit signals the Transmission Control Module (TCM) to maintain line pressure to the PTO. Failure to provide this signal may not be sufficient to the PTO. This may cause damage to the PTO and /or Transmission. Please see the Allison Transmission website and individual chassis manufacturer for installation details.

CAUTION: The torque values given for specific application pages may be limited to the rated torque of the Allison transmission.

- (7) Input Gear Part No. 5-P-1428-11X
- (8) Input Gear Part No. 5-P-1428-12X
- (9) Input Gear Part No. 5-P-1428-3X
- (10) Input Gear Part No. 5-P-1428-4X
- (11) Input Gear Part No. 5-P-1428-5X
- (12) Input Gear Part No. 5-P-1428-6X
- (13) Input Gear Part No. 5-P-1428-7X
- (14) Input Gear Part No. 5-P-1428-8X

Allison

CHELSEA®

ALLISON

ALL-16

MD-3066P (Europe Only)	3500 SP (Side/Top PTO Provision)
3000 RDS (Side/Top PTO Provision)	3000 (International - Side/Top PTO Provision)
3500 RDS (Side/Top PTO Provision)	3200 (International - Side/Top PTO Provision)
3500 ORS (Side/Top PTO Provision)	3500 (International - Side/Top PTO Provision)
3200 ORS (Side/Top PTO Provision)	
3000 ORS (Side/Top PTO Provision)	
3000 SP (Side/Top PTO Provision)	
3200 SP (Side/Top PTO Provision)	

LEFT SIDE ONLY

TOP SIDE ONLY

TRANSMISSION GEAR DATA:
L.S. 10-BOLT Opening Gear FORWARD of Centerline
83 Teeth - L.H. HELIX
PITCH LINE TO APERTURE FACE:
1.7800" (45.2100MM)

TRANSMISSION GEAR DATA:
TOP 10-BOLT Opening Gear FORWARD of Centerline
83 Teeth - L.H. HELIX
PITCH LINE TO APERTURE FACE:
1.7800" (45.2100MM)

CAUTION: Application Approval Required for PTO Output Shaft Speeds Above 2500 RPM

PTO Model	Torq	Dir Rot	Engine %		Filler Block	Adapter Assy	Stud Kit	PTO Model	Torq	Dir Rot	Engine %		Filler Block	Adapter Assy	Stud Kit
	I / C †		Fwd	Rev					I / C †		Fwd	Rev			

ONE SPEED - CONSTANT MESH EXTENDED SHAFT

897EGFJW-*5 (13)	274 C	Eng	177				Furnished
897EHFJW-*5 (14)	258 C	Eng	188				Furnished

† I = Intermittent Torque Only - De-rate Torque Rating 30% for Continuous Duty.

C = Continuous or Intermittent Torque - No need to De-Rate Torque Rating.

IMPORTANT: Refer to the back of this transmission section and read all notes associated with this application page. Some notes may affect the proper PTO selection.

CAUTION: Chelsea Recommends the Power Take-Off (PTO) installation on the 3000/4000 Series Transmissions to utilize a Vehicle Interface Module, or Chassis Manufacturer's equivalent controller to incorporate all the PTO control features available, this includes the "PTO Request" and "PTO Enable Output" feature. The "PTO Enable" circuit signals the Transmission Control Module (TCM) to maintain line pressure to the PTO. Failure to provide this signal may not be sufficient to the PTO. This may cause damage to the PTO and /or Transmission. Please see the Allison Transmission website and individual chassis manufacturer for installation details.

CAUTION: The torque values given for specific application pages may be limited to the rated torque of the Allison transmission.

(13) Input Gear Part No. 5-P-1428-7X
(14) Input Gear Part No. 5-P-1428-8X

ALL-16C

ALLISON

CHELSEA®

3000 (3000 Family Side/Top PTO Provision w/ Integral Cooler)

LEFT SIDE ONLY

TOP SIDE ONLY

TRANSMISSION GEAR DATA:

L.S. 10-BOLT Opening Gear FORWARD of Centerline
83 Teeth - L.H. HELIX

PITCH LINE TO APERTURE FACE:

1.7800" (45.2100MM)

TRANSMISSION GEAR DATA:

TOP 10-BOLT Opening Gear FORWARD of Centerline
83 Teeth - L.H. HELIX

PITCH LINE TO APERTURE FACE:

1.7800" (45.2100MM)

CAUTION: Application Approval Required for PTO Output Shaft Speeds Above 2500 RPM

PTO Model	Torq l / C †	Dir Rot	Engine %		Filler Block	Adapter Assy	Stud Kit	PTO Model	Torq l / C †	Dir Rot	Engine %		Filler Block	Adapter Assy	Stud Kit
			Fwd	Rev							Fwd	Rev			

ONE SPEED - TWO GEAR - CONSTANT MESH

267SBFJP-*5 (4)	402 l	Eng	88				Furnished	267SBFJP-*3 (4)	402 l	Eng	88				Furnished
267SDFJP-*5 (3)	390 l	Eng	106				Furnished	267SDFJP-*3 (3)	390 l	Eng	106				Furnished
267SGFJP-*5 (2)	360 l	Eng	126				Furnished	267SGFJP-*3 (2)	360 l	Eng	126				Furnished
267SMFJP-*5 (5)	309 l	Eng	157				Furnished	267SMFJP-*3 (5)	309 l	Eng	157				Furnished
267SSFJP-*5 (1)	247 l	Eng	196				Furnished	267SSFJP-*3 (1)	247 l	Eng	196				Furnished
267XBFJP-*5 (25)	335 l	Eng	88				Furnished	267XBFJP-*3 (25)	335 l	Eng	88				Furnished
267XDFJP-*5 (26)	325 l	Eng	106				Furnished	267XDFJP-*3 (26)	325 l	Eng	106				Furnished
267XGFJP-*5 (27)	300 l	Eng	126				Furnished	267XGFJP-*3 (27)	300 l	Eng	126				Furnished
267XMFJP-*5 (28)	265 l	Eng	157				Furnished	267XMFJP-*3 (28)	265 l	Eng	157				Furnished
267XSFJP-*5 (1)	247 l	Eng	196				Furnished	267XSFJP-*3 (1)	247 l	Eng	196				Furnished
287GBFJP-*5 (17)	300 C	Eng	73				Furnished	287GBFJP-*3 (17)	300 C	Eng	73				Furnished
287GBFJP-*8 (17)	300 C	Eng	69				Furnished	287GBFJP-*8 (17)	300 C	Eng	69				Furnished
287GCFJP-*5 (18)	390 C	Eng	88				Furnished	287GCFJP-*3 (18)	390 C	Eng	88				Furnished
287GCFJP-*8 (18)	390 C	Eng	83				Furnished	287GCFJP-*8 (18)	390 C	Eng	83				Furnished
287GDFJP-*5 (19)	390 C	Eng	87				Furnished	287GDFJP-*3 (19)	390 C	Eng	87				Furnished
287GDFJP-*8 (19)	390 C	Eng	99				Furnished	287GDFJP-*8 (19)	390 C	Eng	99				Furnished
287GGFJP-*5 (20)	360 C	Eng	126				Furnished	287GGFJP-*3 (20)	360 C	Eng	126				Furnished
287GGFJP-*8 (20)	360 C	Eng	117				Furnished	287GGFJP-*8 (20)	360 C	Eng	117				Furnished
287GKFJP-*5 (21)	340 C	Eng	140				Furnished	287GKFJP-*3 (21)	340 C	Eng	140				Furnished
287GMFJP-*5 (22)	309 C	Eng	157				Furnished	287GMFJP-*3 (22)	309 C	Eng	157				Furnished
287GMFJP-*8 (22)	318 C	Eng	145				Furnished	287GMFJP-*8 (22)	318 C	Eng	145				Furnished
287GPFJP-*5 (23)	275 C	Eng	175				Furnished	287GPFJP-*3 (23)	275 C	Eng	175				Furnished
287GPFJP-*8 (23)	290 C	Eng	162				Furnished	287GPFJP-*8 (23)	290 C	Eng	162				Furnished
287GSFJP-*5 (24)	247 C	Eng	196				Furnished	287GSFJP-*3 (24)	247 C	Eng	196				Furnished
287GSFJP-*8 (24)	265 C	Eng	180				Furnished	287GSFJP-*8 (24)	265 C	Eng	180				Furnished
287GTFJP-*8 (16)	230 C	Eng	211				Furnished	287GTFJP-*8 (16)	230 C	Eng	211				Furnished
877XAFJP-*5 (7)	485 C	Eng	100				Furnished	877XAFJP-*3 (7)	485 C	Eng	100				Furnished
877XBFJP-*5 (8)	458 C	Eng	106				Furnished	877XBFJP-*3 (8)	458 C	Eng	106				Furnished
877XCFJP-*5 (9)	425 C	Eng	114				Furnished	877XCFJP-*3 (9)	425 C	Eng	114				Furnished
877XDFJP-*5 (10)	401 C	Eng	121				Furnished	877XDFJP-*3 (10)	401 C	Eng	121				Furnished
877XEFJP-*5 (11)	351 C	Eng	138				Furnished	877XEFJP-*3 (11)	351 C	Eng	138				Furnished
877XFFJP-*5 (12)	311C	Eng	156				Furnished	877XFFJP-*3 (12)	311C	Eng	156				Furnished

Continued on Next Page

† I = Intermittent Torque Only - De-rate Torque Rating 30% for Continuous Duty.

C = Continuous or Intermittent Torque - No need to De-Rate Torque Rating.

IMPORTANT: Refer to the back of this transmission section and read all notes associated with this application page. Some notes may affect the proper PTO selection.

CAUTION: Chelsea Recommends the Power Take-Off (PTO) installation on the 3000/4000 Series Transmissions to utilize a Vehicle Interface Module, or Chassis Manufacturer's equivalent controller to incorporate all the PTO control features available, this includes the "PTO Request" and "PTO Enable Output" feature. The "PTO Enable" circuit signals the Transmission Control Module (TCM) to maintain line pressure to the PTO. Failure to provide this signal may not be sufficient to the PTO. This may cause damage to the PTO and /or Transmission. Please see the Allison Transmission website and individual chassis manufacturer for installation details.

CAUTION: The torque values given for specific application pages may be limited to the rated torque of the Allison transmission.

- | | | | |
|-------------------------------------|---------------------------------------|--------------------------------------|--------------------------------------|
| 1) Input Gear Part No. 5-P-1173 | (8) Input Gear Part No. 5-P-1428-12X | (17) Input Gear Part No. 5-P-1491-1X | (23) Input Gear Part No. 5-P-1491-7X |
| 2) Input Gear Part No. 5-P-1225 | (9) Input Gear Part No. 5-P-1428-3X | (18) Input Gear Part No. 5-P-1491-2X | (24) Input Gear Part No. 5-P-1491-8X |
| 3) Input Gear Part No. 5-P-1293 | (10) Input Gear Part No. 5-P-1428-4X | (19) Input Gear Part No. 5-P-1491-3X | (25) Input Gear Part No. 5-P-912 |
| 4) Input Gear Part No. 5-P-1350 | (11) Input Gear Part No. 5-P-1428-5X | (20) Input Gear Part No. 5-P-1491-4X | (26) Input Gear Part No. 5-P-913 |
| 5) Input Gear Part No. 5-P-1351 | (12) Input Gear Part No. 5-P-1428-6X | (21) Input Gear Part No. 5-P-1491-5X | (27) Input Gear Part No. 5-P-914 |
| 7) Input Gear Part No. 5-P-1428-11X | (16) Input Gear Part No. 5-P-1491-10X | (22) Input Gear Part No. 5-P-1491-6X | (28) Input Gear Part No. 5-P-915 |

Allison



October 2022
5.2.42

Parker Hannifin Corporation
Chelsea Products Division
Olive Branch, MS 38654 USA

CHELSEA®

ALLISON

ALL-16C

3000 (3000 Family Side/Top PTO Provision w/ Integral Cooler)

LEFT SIDE ONLY

TOP SIDE ONLY

TRANSMISSION GEAR DATA:

L.S. 10-BOLT Opening Gear FORWARD of Centerline
83 Teeth - L.H. HELIX

PITCH LINE TO APERTURE FACE:

1.7800" (45.2100MM)

TRANSMISSION GEAR DATA:

TOP 10-BOLT Opening Gear FORWARD of Centerline
83 Teeth - L.H. HELIX

PITCH LINE TO APERTURE FACE:

1.7800" (45.2100MM)

CAUTION: Application Approval Required for PTO Output Shaft Speeds Above 2500 RPM

PTO Model	Torq I / C †	Dir Rot	Engine %		Filler Block	Adapter Assy	Stud Kit	PTO Model	Torq I / C †	Dir Rot	Engine %		Filler Block	Adapter Assy	Stud Kit
			Fwd	Rev							Fwd	Rev			

ONE SPEED - TWO GEAR - CONSTANT MESH

877XGFJP-*5 (13)	274 C	Eng	177				Furnished	877XGFJP-*3 (13)	274 C	Eng	177				Furnished
877XHFJP-*5 (14)	258 C	Eng	188				Furnished	877XHFJP-*3 (14)	258 C	Eng	188				Furnished
877XJFJP-*5 (15)	242 C	Eng	200				Furnished	877XJFJP-*3 (15)	242 C	Eng	200				Furnished
877XKFJP-*5 (6)	292 C	Eng	166				Furnished	877XKFJP-*3 (6)	292 C	Eng	166				Furnished

ONE SPEED - TWO GEAR - POWERSHIFT (HYDRAULIC)

280GBFJP-*5 (17)	300 C	Eng	73				Furnished	280GBFJP-*3 (17)	300 C	Eng	73				Furnished
280GBFJP-*8 (17)	300 C	Eng	69				Furnished	280GBFJP-*8 (17)	300 C	Eng	69				Furnished
280GCFJP-*5 (18)	390 C	Eng	88				Furnished	280GCFJP-*3 (18)	390 C	Eng	88				Furnished
280GCFJP-*8 (18)	390 C	Eng	83				Furnished	280GCFJP-*8 (18)	390 C	Eng	83				Furnished
280GDFJP-*5 (19)	390 C	Eng	106				Furnished	280GDFJP-*3 (19)	390 C	Eng	106				Furnished
280GDFJP-*8 (19)	390 C	Eng	99				Furnished	280GDFJP-*8 (19)	390 C	Eng	99				Furnished
280GGFJP-*5 (20)	360 C	Eng	126				Furnished	280GGFJP-*3 (20)	360 C	Eng	126				Furnished
280GGFJP-*8 (20)	360 C	Eng	117				Furnished	280GGFJP-*8 (20)	360 C	Eng	117				Furnished
280GKFJP-*5 (21)	340 C	Eng	140				Furnished	280GKFJP-*3 (21)	340 C	Eng	140				Furnished
280GMFJP-*5 (22)	309 C	Eng	157				Furnished	280GMFJP-*3 (22)	309 C	Eng	157				Furnished
280GMFJP-*8 (22)	318 C	Eng	145				Furnished	280GMFJP-*8 (22)	318 C	Eng	145				Furnished
280GPFJP-*5 (23)	275 C	Eng	175				Furnished	280GPFJP-*3 (23)	275 C	Eng	175				Furnished
280GPFJP-*8 (23)	290 C	Eng	162				Furnished	280GPFJP-*8 (23)	290 C	Eng	162				Furnished
280GSFJP-*5 (24)	247 C	Eng	196				Furnished	280GSFJP-*3 (24)	247 C	Eng	196				Furnished
280GSFJP-*8 (24)	265 C	Eng	180				Furnished	280GSFJP-*8 (24)	265 C	Eng	180				Furnished
280GTFJP-*8 (16)	230 C	Eng	211				Furnished	280GTFJP-*8 (16)	230 C	Eng	211				Furnished
870XAFJP-*5 (7)	485 C	Eng	100				Furnished	870XAFJP-*3 (7)	485 C	Eng	100				Furnished
870XBFJP-*5 (8)	458 C	Eng	106				Furnished	870XBFJP-*3 (8)	458 C	Eng	106				Furnished
870XCFJP-*5 (9)	425 C	Eng	114				Furnished	870XCFJP-*3 (9)	425 C	Eng	114				Furnished
870XDFJP-*5 (10)	401 C	Eng	121				Furnished	870XDFJP-*3 (10)	401 C	Eng	121				Furnished
870XEFJP-*5 (11)	351 C	Eng	138				Furnished	870XEFJP-*3 (11)	351 C	Eng	138				Furnished
870XFFJP-*5 (12)	311 C	Eng	156				Furnished	870XFFJP-*3 (12)	311 C	Eng	156				Furnished
870XGFJP-*5 (13)	274 C	Eng	177				Furnished	870XGFJP-*3 (13)	274 C	Eng	177				Furnished
870XHFJP-*5 (14)	258 C	Eng	188				Furnished	870XHFJP-*3 (14)	258 C	Eng	188				Furnished
870XJFJP-*5 (15)	242 C	Eng	200				Furnished	870XJFJP-*3 (15)	242 C	Eng	200				Furnished

Continued on Next Page

† I = Intermittent Torque Only - De-rate Torque Rating 30% for Continuous Duty.

C = Continuous or Intermittent Torque - No need to De-Rate Torque Rating.

IMPORTANT: Refer to the back of this transmission section and read all notes associated with this application page. Some notes may affect the proper PTO selection.

CAUTION: Chelsea Recommends the Power Take-Off (PTO) installation on the 3000/4000 Series Transmissions to utilize a Vehicle Interface Module, or Chassis Manufacturer's equivalent controller to incorporate all the PTO control features available, this includes the "PTO Request" and "PTO Enable Output" feature. The "PTO Enable" circuit signals the Transmission Control Module (TCM) to maintain line pressure to the PTO. Failure to provide this signal may not be sufficient to the PTO. This may cause damage to the PTO and /or Transmission. Please see the Allison Transmission website and individual chassis manufacturer for installation details.

CAUTION: The torque values given for specific application pages may be limited to the rated torque of the Allison transmission.

(6) Input Gear Part No. 5-P-1428-10X
(7) Input Gear Part No. 5-P-1428-11X
(8) Input Gear Part No. 5-P-1428-12X
(9) Input Gear Part No. 5-P-1428-3X
(10) Input Gear Part No. 5-P-1428-4X
(11) Input Gear Part No. 5-P-1428-5X

(12) Input Gear Part No. 5-P-1428-6X
(13) Input Gear Part No. 5-P-1428-7X
(14) Input Gear Part No. 5-P-1428-8X
(15) Input Gear Part No. 5-P-1428-9X
(16) Input Gear Part No. 5-P-1491-10X
(17) Input Gear Part No. 5-P-1491-1X

(18) Input Gear Part No. 5-P-1491-2X
(19) Input Gear Part No. 5-P-1491-3X
(20) Input Gear Part No. 5-P-1491-4X
(21) Input Gear Part No. 5-P-1491-5X
(22) Input Gear Part No. 5-P-1491-6X
(23) Input Gear Part No. 5-P-1491-7X

(24) Input Gear Part No. 5-P-1491-8X

ALL-16C

ALLISON

CHELSEA®

3000 (3000 Family Side/Top PTO Provision w/ Integral Cooler)

LEFT SIDE ONLY

TOP SIDE ONLY

TRANSMISSION GEAR DATA:

L.S. 10-BOLT Opening Gear FORWARD of Centerline
83 Teeth - L.H. HELIX

PITCH LINE TO APERTURE FACE:

1.7800" (45.2100MM)

TRANSMISSION GEAR DATA:

TOP 10-BOLT Opening Gear FORWARD of Centerline
83 Teeth - L.H. HELIX

PITCH LINE TO APERTURE FACE:

1.7800" (45.2100MM)

CAUTION: Application Approval Required for PTO Output Shaft Speeds Above 2500 RPM

PTO Model	Torq I / C †	Dir Rot	Engine %		Filler Block	Adapter Assy	Stud Kit	PTO Model	Torq I / C †	Dir Rot	Engine %		Filler Block	Adapter Assy	Stud Kit
			Fwd	Rev							Fwd	Rev			

ONE SPEED - POWERSHIFT (HYDRAULIC) EXTENDED SHAFT

870LAFJW-*5 (7)	485 C	Eng	100				Furnished	890TAFJW-*5 (7)	485 C	Eng	100				Furnished
870LBFJW-*5 (8)	458 C	Eng	106				Furnished	890TBFJW-*5 (8)	458 C	Eng	106				Furnished
870LCFJW-*5 (9)	425 C	Eng	114				Furnished	890TCFJW-*5 (9)	425 C	Eng	114				Furnished
870LDFJW-*5 (10)	401 C	Eng	121				Furnished	890TDFJW-*5 (10)	401 C	Eng	121				Furnished
870LEFJW-*5 (11)	351 C	Eng	138				Furnished	890TEFJW-*5 (11)	351 C	Eng	138				Furnished
870LFFJW-*5 (12)	311 C	Eng	156				Furnished	890TFFJW-*5 (12)	311 C	Eng	156				Furnished
870LGFJW-*5 (13)	274 C	Eng	177				Furnished	890TGFJW-*5 (13)	274 C	Eng	177				Furnished
870LHFJW-*5 (14)	258 C	Eng	188				Furnished	890THFJW-*5 (14)	258 C	Eng	188				Furnished

ONE SPEED - CONSTANT MESH EXTENDED SHAFT

877LAFJW-*5 (7)	485 C	Eng	100				Furnished	897TAFJW-*5 (7)	485 C	Eng	100				Furnished
877LBFJW-*5 (8)	458 C	Eng	106				Furnished	897TBFJW-*5 (8)	458 C	Eng	106				Furnished
877LCFJW-*5 (9)	425 C	Eng	114				Furnished	897TCFJW-*5 (9)	425 C	Eng	114				Furnished
877LDFJW-*5 (10)	401 C	Eng	121				Furnished	897TDFJW-*5 (10)	401 C	Eng	121				Furnished
877LEFJW-*5 (11)	351 C	Eng	138				Furnished	897TEFJW-*5 (11)	351 C	Eng	138				Furnished
877LFFJW-*5 (12)	311 C	Eng	156				Furnished	897TFFJW-*5 (12)	311 C	Eng	156				Furnished
877LGFJW-*5 (13)	274 C	Eng	177				Furnished	897TGFJW-*5 (13)	274 C	Eng	177				Furnished
877LHFJW-*5 (14)	258 C	Eng	188				Furnished	897THFJW-*5 (14)	258 C	Eng	188				Furnished

† I = Intermittent Torque Only - De-rate Torque Rating 30% for Continuous Duty.

C = Continuous or Intermittent Torque - No need to De-Rate Torque Rating.

IMPORTANT: Refer to the back of this transmission section and read all notes associated with this application page. Some notes may affect the proper PTO selection.

CAUTION: Chelsea Recommends the Power Take-Off (PTO) installation on the 3000/4000 Series Transmissions to utilize a Vehicle Interface Module, or Chassis Manufacturer's equivalent controller to incorporate all the PTO control features available, this includes the "PTO Request" and "PTO Enable Output" feature. The "PTO Enable" circuit signals the Transmission Control Module (TCM) to maintain line pressure to the PTO. Failure to provide this signal may not be sufficient to the PTO. This may cause damage to the PTO and /or Transmission. Please see the Allison Transmission website and individual chassis manufacturer for installation details.

CAUTION: The torque values given for specific application pages may be limited to the rated torque of the Allison transmission.

- (7) Input Gear Part No. 5-P-1428-11X
- (8) Input Gear Part No. 5-P-1428-12X
- (9) Input Gear Part No. 5-P-1428-3X
- (10) Input Gear Part No. 5-P-1428-4X
- (11) Input Gear Part No. 5-P-1428-5X
- (12) Input Gear Part No. 5-P-1428-6X

- (13) Input Gear Part No. 5-P-1428-7X
- (14) Input Gear Part No. 5-P-1428-8X

CHELSEA®

ALLISON

ALL-16EV

3000 EVS (Emergency Vehicles Only Top / Side PTO Provisions)
3500 EVS (Emergency Vehicles Only Top / Side PTO Provisions)

LEFT SIDE ONLY

TOP SIDE ONLY

TRANSMISSION GEAR DATA:

L.S. 10-BOLT Opening Gear FORWARD of Centerline
83 Teeth - L.H. HELIX

PITCH LINE TO APERTURE FACE:

1.7800" (45.2100MM)

TRANSMISSION GEAR DATA:

TOP 10-BOLT Opening Gear FORWARD of Centerline
83 Teeth - L.H. HELIX

PITCH LINE TO APERTURE FACE:

1.7800" (45.2100MM)

CAUTION: Application Approval Required for PTO Output Shaft Speeds Above 2500 RPM

PTO Model	Torq I / C †	Dir Rot	Engine %		Filler Block	Adapter Assy	Stud Kit	PTO Model	Torq I / C †	Dir Rot	Engine %		Filler Block	Adapter Assy	Stud Kit
			Fwd	Rev							Fwd	Rev			

ONE SPEED - TWO GEAR - CONSTANT MESH

267SBFJP-*5 (4)	402 I	Eng	88				Furnished	267SBFJP-*3 (4)	402 I	Eng	88				Furnished
267SDFJP-*5 (3)	390 I	Eng	106				Furnished	267SDFJP-*3 (3)	390 I	Eng	106				Furnished
267SGFJP-*5 (2)	360 I	Eng	126				Furnished	267SGFJP-*3 (2)	360 I	Eng	126				Furnished
267SMFJP-*5 (5)	309 I	Eng	157				Furnished	267SMFJP-*3 (5)	309 I	Eng	157				Furnished
267SSFJP-*5 (1)	247 I	Eng	196				Furnished	267SSFJP-*3 (1)	247 I	Eng	196				Furnished
267XBFJP-*5 (25)	335 I	Eng	88				Furnished	267XBFJP-*3 (25)	335 I	Eng	88				Furnished
267XDFJP-*5 (26)	325 I	Eng	106				Furnished	267XDFJP-*3 (26)	325 I	Eng	106				Furnished
267XGFJP-*5 (27)	300 I	Eng	126				Furnished	267XGFJP-*3 (27)	300 I	Eng	126				Furnished
267XMFJP-*5 (28)	265 I	Eng	157				Furnished	267XMFJP-*3 (28)	265 I	Eng	157				Furnished
267XSFJP-*5 (1)	247 I	Eng	196				Furnished	267XSFJP-*3 (1)	247 I	Eng	196				Furnished
287GBFJP-*5 (17)	300 C	Eng	73				Furnished	287GBFJP-*3 (17)	300 C	Eng	73				Furnished
287GBFJP-*8 (17)	300 C	Eng	69				Furnished	287GBFJP-*8 (17)	300 C	Eng	69				Furnished
287GCFJP-*5 (18)	390 C	Eng	88				Furnished	287GCFJP-*3 (18)	390 C	Eng	88				Furnished
287GCFJP-*8 (18)	390 C	Eng	83				Furnished	287GCFJP-*8 (18)	390 C	Eng	83				Furnished
287GDFJP-*5 (19)	390 C	Eng	87				Furnished	287GDFJP-*3 (19)	390 C	Eng	87				Furnished
287GDFJP-*8 (19)	390 C	Eng	99				Furnished	287GDFJP-*8 (19)	390 C	Eng	99				Furnished
287GGFJP-*5 (20)	360 C	Eng	126				Furnished	287GGFJP-*3 (20)	360 C	Eng	126				Furnished
287GGFJP-*8 (20)	360 C	Eng	117				Furnished	287GGFJP-*8 (20)	360 C	Eng	117				Furnished
287GKFJP-*5 (21)	340 C	Eng	140				Furnished	287GKFJP-*3 (21)	340 C	Eng	140				Furnished
287GMFJP-*5 (22)	318 C	Eng	157				Furnished	287GMFJP-*3 (22)	318 C	Eng	157				Furnished
287GMFJP-*8 (22)	318 C	Eng	145				Furnished	287GMFJP-*8 (22)	318 C	Eng	145				Furnished
287GPFJP-*5 (23)	290 C	Eng	175				Furnished	287GPFJP-*3 (23)	290 C	Eng	175				Furnished
287GPFJP-*8 (23)	290 C	Eng	162				Furnished	287GPFJP-*8 (23)	290 C	Eng	162				Furnished
287GSFJP-*5 (24)	265 C	Eng	196				Furnished	287GSFJP-*3 (24)	265 C	Eng	196				Furnished
287GSFJP-*8 (24)	265 C	Eng	180				Furnished	287GSFJP-*8 (24)	265 C	Eng	180				Furnished
287GTFJP-*8 (16)	230 C	Eng	211				Furnished	287GTFJP-*8 (16)	230 C	Eng	211				Furnished
877XAFJP-*5 (7)	670 C	Eng	100				Furnished	877XAFJP-*3 (7)	670 C	Eng	100				Furnished
877XBFJP-*5 (8)	632 C	Eng	106				Furnished	877XBFJP-*3 (8)	632 C	Eng	106				Furnished
877XCFJP-*5 (9)	588 C	Eng	114				Furnished	877XCFJP-*3 (9)	588 C	Eng	114				Furnished
877XDFJP-*5 (10)	554 C	Eng	121				Furnished	877XDFJP-*3 (10)	554 C	Eng	121				Furnished
877XEFJP-*5 (11)	486C	Eng	138				Furnished	877XEFJP-*3 (11)	486C	Eng	138				Furnished
877XFFJP-*5 (12)	429 C	Eng	156				Furnished	877XFFJP-*3 (12)	429 C	Eng	156				Furnished

Continued on Next Page

† I = Intermittent Torque Only - De-rate Torque Rating 30% for Continuous Duty.

C = Continuous or Intermittent Torque - No need to De-Rate Torque Rating.

IMPORTANT: Refer to the back of this transmission section and read all notes associated with this application page. Some notes may affect the proper PTO selection.

CAUTION: Chelsea Recommends the Power Take-Off (PTO) installation on the 3000/4000 Series Transmissions to utilize a Vehicle Interface Module, or Chassis Manufacturer's equivalent controller to incorporate all the PTO control features available, this includes the "PTO Request" and "PTO Enable Output" feature. The "PTO Enable" circuit signals the Transmission Control Module (TCM) to maintain line pressure to the PTO. Failure to provide this signal may not be sufficient to the PTO. This may cause damage to the PTO and /or Transmission. Please see the Allison Transmission website and individual chassis manufacturer for installation details.

(1) Input Gear Part No. 5-P-1173
(2) Input Gear Part No. 5-P-1225
(3) Input Gear Part No. 5-P-1293
(4) Input Gear Part No. 5-P-1350
(5) Input Gear Part No. 5-P-1351
(7) Input Gear Part No. 5-P-1428-11X

(8) Input Gear Part No. 5-P-1428-12X
(9) Input Gear Part No. 5-P-1428-3X
(10) Input Gear Part No. 5-P-1428-4X
(11) Input Gear Part No. 5-P-1428-5X
(12) Input Gear Part No. 5-P-1428-6X
(16) Input Gear Part No. 5-P-1491-10X

(17) Input Gear Part No. 5-P-1491-1X
(18) Input Gear Part No. 5-P-1491-2X
(19) Input Gear Part No. 5-P-1491-3X
(20) Input Gear Part No. 5-P-1491-4X
(21) Input Gear Part No. 5-P-1491-5X
(22) Input Gear Part No. 5-P-1491-6X

(23) Input Gear Part No. 5-P-1491-7X
(24) Input Gear Part No. 5-P-1491-8X
(25) Input Gear Part No. 5-P-912
(26) Input Gear Part No. 5-P-913
(27) Input Gear Part No. 5-P-914
(28) Input Gear Part No. 5-P-915

ALL-16EV

ALLISON

CHELSEA®

3000 EVS (Emergency Vehicles Only Top / Side PTO Provisions)
3500 EVS (Emergency Vehicles Only Top / Side PTO Provisions)

LEFT SIDE ONLY

TOP SIDE ONLY

TRANSMISSION GEAR DATA:

L.S. 10-BOLT Opening Gear FORWARD of Centerline
83 Teeth - L.H. HELIX

PITCH LINE TO APERTURE FACE:

1.7800" (45.2100MM)

TRANSMISSION GEAR DATA:

TOP 10-BOLT Opening Gear FORWARD of Centerline
83 Teeth - L.H. HELIX

PITCH LINE TO APERTURE FACE:

1.7800" (45.2100MM)

CAUTION: Application Approval Required for PTO Output Shaft Speeds Above 2500 RPM

PTO Model	Torq I / C †	Dir Rot	Engine %		Filler Block	Adapter Assy	Stud Kit	PTO Model	Torq I / C †	Dir Rot	Engine %		Filler Block	Adapter Assy	Stud Kit
			Fwd	Rev							Fwd	Rev			

ONE SPEED - TWO GEAR - CONSTANT MESH

877XGFJP-*5 (13)	379 C	Eng	177			Furnished	877XGFJP-*3 (13)	379 C	Eng	177					Furnished
877XHFJP-*5 (14)	356 C	Eng	188			Furnished	877XHFJP-*3 (14)	356 C	Eng	188					Furnished
877XJFJP-*5 (15)	334 C	Eng	200			Furnished	877XJFJP-*3 (15)	334 C	Eng	200					Furnished
877XKFJP-*5 (6)	404 C	Eng	166			Furnished	877XKFJP-*3 (6)	404 C	Eng	166					Furnished

ONE SPEED - TWO GEAR - POWERSHIFT (HYDRAULIC)

280GBFJP-*5 (17)	300 C	Eng	73			Furnished	280GBFJP-*3 (17)	300 C	Eng	73					Furnished
280GBFJP-*8 (17)	300 C	Eng	69			Furnished	280GBFJP-*8 (17)	300 C	Eng	69					Furnished
280GCFJP-*5 (18)	390 C	Eng	88			Furnished	280GCFJP-*3 (18)	390 C	Eng	88					Furnished
280GCFJP-*8 (18)	390 C	Eng	83			Furnished	280GCFJP-*8 (18)	390 C	Eng	83					Furnished
280GDFJP-*5 (19)	390 C	Eng	106			Furnished	280GDFJP-*3 (19)	390 C	Eng	106					Furnished
280GDFJP-*8 (19)	390 C	Eng	99			Furnished	280GDFJP-*8 (19)	390 C	Eng	99					Furnished
280GGFJP-*5 (20)	360 C	Eng	126			Furnished	280GGFJP-*3 (20)	360 C	Eng	126					Furnished
280GGFJP-*8 (20)	360 C	Eng	117			Furnished	280GGFJP-*8 (20)	360 C	Eng	117					Furnished
280GKFJP-*5 (21)	340 C	Eng	140			Furnished	280GKFJP-*3 (21)	340 C	Eng	140					Furnished
280GMFJP-*5 (22)	318 C	Eng	157			Furnished	280GMFJP-*3 (22)	318 C	Eng	157					Furnished
280GMFJP-*8 (22)	318 C	Eng	145			Furnished	280GMFJP-*8 (22)	318 C	Eng	145					Furnished
280GPFJP-*5 (23)	290 C	Eng	175			Furnished	280GPFJP-*3 (23)	290 C	Eng	175					Furnished
280GPFJP-*8 (23)	290 C	Eng	162			Furnished	280GPFJP-*8 (23)	290 C	Eng	162					Furnished
280GSFJP-*5 (24)	265 C	Eng	196			Furnished	280GSFJP-*3 (24)	265 C	Eng	196					Furnished
280GSFJP-*8 (24)	265 C	Eng	180			Furnished	280GSFJP-*8 (24)	265 C	Eng	180					Furnished
280GTFJP-*8 (16)	230 C	Eng	211			Furnished	280GTFJP-*8 (16)	230 C	Eng	211					Furnished
870XAFJP-*5 (7)	670 C	Eng	100			Furnished	870XAFJP-*3 (7)	670 C	Eng	100					Furnished
870XBFJP-*5 (8)	632 C	Eng	106			Furnished	870XBFJP-*3 (8)	632 C	Eng	106					Furnished
870XCFJP-*5 (9)	588 C	Eng	114			Furnished	870XCFJP-*3 (9)	588 C	Eng	114					Furnished
870XDFJP-*5 (10)	554 C	Eng	121			Furnished	870XDFJP-*3 (10)	554 C	Eng	121					Furnished
870XEFJP-*5 (11)	486 C	Eng	138			Furnished	870XEFJP-*3 (11)	486 C	Eng	138					Furnished
870XFFJP-*5 (12)	429 C	Eng	156			Furnished	870XFFJP-*3 (12)	429 C	Eng	156					Furnished
870XGFJP-*5 (13)	379 C	Eng	177			Furnished	870XGFJP-*3 (13)	379 C	Eng	177					Furnished
870XHFJP-*5 (14)	356 C	Eng	188			Furnished	870XHFJP-*3 (14)	356 C	Eng	188					Furnished
870XJFJP-*5 (15)	334 C	Eng	200			Furnished	870XJFJP-*3 (15)	334 C	Eng	200					Furnished

† I = Intermittent Torque Only - De-rate Torque Rating 30% for Continuous Duty.

C = Continuous or Intermittent Torque - No need to De-Rate Torque Rating.

IMPORTANT: Refer to the back of this transmission section and read all notes associated with this application page. Some notes may affect the proper PTO selection.

CAUTION: Chelsea Recommends the Power Take-Off (PTO) installation on the 3000/4000 Series Transmissions to utilize a Vehicle Interface Module, or Chassis Manufacturer's equivalent controller to incorporate all the PTO control features available, this includes the "PTO Request" and "PTO Enable Output" feature. The "PTO Enable" circuit signals the Transmission Control Module (TCM) to maintain line pressure to the PTO. Failure to provide this signal may not be sufficient to the PTO. This may cause damage to the PTO and /or Transmission. Please see the Allison Transmission website and individual chassis manufacturer for installation details.

- (6) Input Gear Part No. 5-P-1428-10X
- (7) Input Gear Part No. 5-P-1428-11X
- (8) Input Gear Part No. 5-P-1428-12X
- (9) Input Gear Part No. 5-P-1428-3X
- (10) Input Gear Part No. 5-P-1428-4X
- (11) Input Gear Part No. 5-P-1428-5X
- (12) Input Gear Part No. 5-P-1428-6X
- (13) Input Gear Part No. 5-P-1428-7X
- (14) Input Gear Part No. 5-P-1428-8X
- (15) Input Gear Part No. 5-P-1428-9X
- (16) Input Gear Part No. 5-P-1491-10X
- (17) Input Gear Part No. 5-P-1491-1X
- (18) Input Gear Part No. 5-P-1491-2X
- (19) Input Gear Part No. 5-P-1491-3X
- (20) Input Gear Part No. 5-P-1491-4X
- (21) Input Gear Part No. 5-P-1491-5X
- (22) Input Gear Part No. 5-P-1491-6X
- (23) Input Gear Part No. 5-P-1491-7X
- (24) Input Gear Part No. 5-P-1491-8X

Allison

CHELSEA®

ALLISON

ALL-16EV

3000 EVS (Emergency Vehicles Only Top / Side PTO Provisions)
3500 EVS (Emergency Vehicles Only Top / Side PTO Provisions)

LEFT SIDE ONLY

TOP SIDE ONLY

TRANSMISSION GEAR DATA:

L.S. 10-BOLT Opening Gear FORWARD of Centerline
83 Teeth - L.H. HELIX

PITCH LINE TO APERTURE FACE:

1.7800" (45.2100MM)

TRANSMISSION GEAR DATA:

TOP 10-BOLT Opening Gear FORWARD of Centerline
83 Teeth - L.H. HELIX

PITCH LINE TO APERTURE FACE:

1.7800" (45.2100MM)

CAUTION: Application Approval Required for PTO Output Shaft Speeds Above 2500 RPM

PTO Model	Torq I / C †	Dir Rot	Engine %		Filler Block	Adapter Assy	Stud Kit	PTO Model	Torq I / C †	Dir Rot	Engine %		Filler Block	Adapter Assy	Stud Kit
			Fwd	Rev							Fwd	Rev			

ONE SPEED - POWERSHIFT (HYDRAULIC) EXTENDED SHAFT

870LAFJW-*5 (7)	670 C	Eng	100				Furnished	890TAFJW-*5 (7)	670 C	Eng	100				Furnished
870LBFJW-*5 (8)	632 C	Eng	106				Furnished	890TBFJW-*5 (8)	632 C	Eng	106				Furnished
870LCFJW-*5 (9)	588 C	Eng	114				Furnished	890TCFJW-*5 (9)	588 C	Eng	114				Furnished
870LDFJW-*5 (10)	554 C	Eng	121				Furnished	890TDFJW-*5 (10)	554 C	Eng	121				Furnished
870LEFJW-*5 (11)	486 C	Eng	138				Furnished	890TEFJW-*5 (11)	486 C	Eng	138				Furnished
870LFFJW-*5 (12)	429 C	Eng	156				Furnished	890TFFJW-*5 (12)	429 C	Eng	156				Furnished
870LGFJW-*5 (13)	378 C	Eng	177				Furnished	890TGFJW-*5 (13)	378 C	Eng	177				Furnished
870LHFJW-*5 (14)	356 C	Eng	188				Furnished	890THFJW-*5 (14)	356 C	Eng	188				Furnished
890EAFJW-*5 (7)	670 C	Eng	100				Furnished								
890EBFJW-*5 (8)	632 C	Eng	106				Furnished								
890ECFJW-*5 (9)	588 C	Eng	114				Furnished								
890EDFJW-*5 (10)	554 C	Eng	121				Furnished								
890EEFJW-*5 (11)	486 C	Eng	138				Furnished								
890EFFJW-*5 (12)	429 C	Eng	156				Furnished								
890EGFJW-*5 (13)	378 C	Eng	177				Furnished								
890EHFJW-*5 (14)	356 C	Eng	188				Furnished								

ONE SPEED - CONSTANT MESH EXTENDED SHAFT

877LAFJW-*5 (7)	670 C	Eng	100				Furnished	897TAFJW-*5 (7)	670 C	Eng	100				Furnished
877LBFJW-*5 (8)	632 C	Eng	106				Furnished	897TBFJW-*5 (8)	632 C	Eng	106				Furnished
877LCFJW-*5 (9)	588 C	Eng	114				Furnished	897TCFJW-*5 (9)	588 C	Eng	114				Furnished
877LDFJW-*5 (10)	554 C	Eng	121				Furnished	897TDFJW-*5 (10)	554 C	Eng	121				Furnished
877LEFJW-*5 (11)	486 C	Eng	138				Furnished	897TEFJW-*5 (11)	486 C	Eng	138				Furnished
877LFFJW-*5 (12)	429 C	Eng	156				Furnished	897TFFJW-*5 (12)	429 C	Eng	156				Furnished
877LGFJW-*5 (13)	378 C	Eng	177				Furnished	897TGFJW-*5 (13)	378 C	Eng	177				Furnished
877LHFJW-*5 (14)	356 C	Eng	188				Furnished	897THFJW-*5 (14)	356 C	Eng	188				Furnished
897EAFJW-*5 (7)	670 C	Eng	100				Furnished								
897EBFJW-*5 (8)	632 C	Eng	106				Furnished								
897ECFJW-*5 (9)	588 C	Eng	114				Furnished								
897EDFJW-*5 (10)	554 C	Eng	121				Furnished								
897EEFJW-*5 (11)	486 C	Eng	138				Furnished								
897EFFJW-*5 (12)	429 C	Eng	156				Furnished								

Continued on Next Page

† I = Intermittent Torque Only - De-rate Torque Rating 30% for Continuous Duty.

C = Continuous or Intermittent Torque - No need to De-Rate Torque Rating.

IMPORTANT: Refer to the back of this transmission section and read all notes associated with this application page. Some notes may affect the proper PTO selection.

CAUTION: Chelsea Recommends the Power Take-Off (PTO) installation on the 3000/4000 Series Transmissions to utilize a Vehicle Interface Module, or Chassis Manufacturer's equivalent controller to incorporate all the PTO control features available, this includes the "PTO Request" and "PTO Enable Output" feature. The "PTO Enable" circuit signals the Transmission Control Module (TCM) to maintain line pressure to the PTO. Failure to provide this signal may not be sufficient to the PTO. This may cause damage to the PTO and /or Transmission. Please see the Allison Transmission website and individual chassis manufacturer for installation details.

(7) Input Gear Part No. 5-P-1428-11X
(8) Input Gear Part No. 5-P-1428-12X
(9) Input Gear Part No. 5-P-1428-3X
(10) Input Gear Part No. 5-P-1428-4X
(11) Input Gear Part No. 5-P-1428-5X
(12) Input Gear Part No. 5-P-1428-6X

(13) Input Gear Part No. 5-P-1428-7X
(14) Input Gear Part No. 5-P-1428-8X

ALL-16EV

ALLISON

CHELSEA®

3000 EVS (Emergency Vehicles Only Top / Side PTO Provisions)
3500 EVS (Emergency Vehicles Only Top / Side PTO Provisions)

LEFT SIDE ONLY

TOP SIDE ONLY

TRANSMISSION GEAR DATA:L.S. 10-BOLT Opening Gear FORWARD of Centerline
83 Teeth - L.H. HELIX**PITCH LINE TO APERTURE FACE:**

1.7800" (45.2100MM)

TRANSMISSION GEAR DATA:TOP 10-BOLT Opening Gear FORWARD of Centerline
83 Teeth - L.H. HELIX**PITCH LINE TO APERTURE FACE:**

1.7800" (45.2100MM)

CAUTION: Application Approval Required for PTO Output Shaft Speeds Above 2500 RPM

PTO Model	Torq	Dir Rot	Engine %		Filler Block	Adapter Assy	Stud Kit	PTO Model	Torq	Dir Rot	Engine %		Filler Block	Adapter Assy	Stud Kit
	I / C †		Fwd	Rev					I / C †		Fwd	Rev			

ONE SPEED - CONSTANT MESH EXTENDED SHAFT

897EGFJW-*5 (13)	378 C	Eng	177				Furnished
897EHFJW-*5 (14)	356 C	Eng	188				Furnished

Continued on Next Page

† I = Intermittent Torque Only - De-rate Torque Rating 30% for Continuous Duty.

C = Continuous or Intermittent Torque - No need to De-Rate Torque Rating.

IMPORTANT: Refer to the back of this transmission section and read all notes associated with this application page. Some notes may affect the proper PTO selection.

CAUTION: Chelsea Recommends the Power Take-Off (PTO) installation on the 3000/4000 Series Transmissions to utilize a Vehicle Interface Module, or Chassis Manufacturer's equivalent controller to incorporate all the PTO control features available, this includes the "PTO Request" and "PTO Enable Output" feature. The "PTO Enable" circuit signals the Transmission Control Module (TCM) to maintain line pressure to the PTO. Failure to provide this signal may not be sufficient to the PTO. This may cause damage to the PTO and /or Transmission. Please see the Allison Transmission website and individual chassis manufacturer for installation details.

(13) Input Gear Part No. 5-P-1428-7X
(14) Input Gear Part No. 5-P-1428-8X

Allison

3000 (3000 Family - Side/Top PTO Provision w/ Retarder)

LEFT SIDE ONLY

TOP SIDE ONLY

TRANSMISSION GEAR DATA:

L.S. 10-BOLT Opening Gear FORWARD of Centerline
83 Teeth - L.H. HELIX

PITCH LINE TO APERTURE FACE:

1.7800" (45.2100MM)

TRANSMISSION GEAR DATA:

TOP 10-BOLT Opening Gear FORWARD of Centerline
83 Teeth - L.H. HELIX

PITCH LINE TO APERTURE FACE:

1.7800" (45.2100MM)

CAUTION: Application Approval Required for PTO Output Shaft Speeds Above 2500 RPM

PTO Model	Torq I / C †	Dir Rot	Engine %		Filler Block	Adapter Assy	Stud Kit	PTO Model	Torq I / C †	Dir Rot	Engine %		Filler Block	Adapter Assy	Stud Kit
			Fwd	Rev							Fwd	Rev			

ONE SPEED - TWO GEAR - CONSTANT MESH

267SBFJP-5 (4)	402 I	Eng	88				Furnished	267SBFJP-3 (4)	402 I	Eng	88				Furnished
267SDFJP-5 (3)	390 I	Eng	106				Furnished	267SDFJP-3 (3)	390 I	Eng	106				Furnished
267SGFJP-5 (2)	360 I	Eng	126				Furnished	267SGFJP-3 (2)	360 I	Eng	126				Furnished
267SMFJP-5 (5)	309 I	Eng	157				Furnished	267SMFJP-3 (5)	309 I	Eng	157				Furnished
267SSFJP-5 (1)	247 I	Eng	196				Furnished	267SSFJP-3 (1)	247 I	Eng	196				Furnished
267XBFJP-5 (25)	335 I	Eng	88				Furnished	267XBFJP-3 (25)	335 I	Eng	88				Furnished
267XDFJP-5 (26)	325 I	Eng	106				Furnished	267XDFJP-3 (26)	325 I	Eng	106				Furnished
267XGFJP-5 (27)	300 I	Eng	126				Furnished	267XGFJP-3 (27)	300 I	Eng	126				Furnished
267XMFJP-5 (28)	265 I	Eng	157				Furnished	267XMFJP-3 (28)	265 I	Eng	157				Furnished
267XSFJP-5 (1)	247 I	Eng	196				Furnished	267XSFJP-3 (1)	247 I	Eng	196				Furnished
287GBFJP-5 (17)	300 C	Eng	73				Furnished	287GBFJP-3 (17)	300 C	Eng	73				Furnished
287GBFJP-8 (17)	300 C	Eng	69				Furnished	287GBFJP-3 (17)	300 C	Eng	69				Furnished
287GCFJP-5 (18)	390 C	Eng	88				Furnished	287GCFJP-3 (18)	390 C	Eng	88				Furnished
287GCFJP-8 (18)	390 C	Eng	83				Furnished	287GCFJP-3 (18)	390 C	Eng	83				Furnished
287GDFJP-5 (19)	390 C	Eng	87				Furnished	287GDFJP-3 (19)	390 C	Eng	87				Furnished
287GDFJP-8 (19)	390 C	Eng	99				Furnished	287GDFJP-3 (19)	390 C	Eng	99				Furnished
287GGFJP-5 (20)	360 C	Eng	126				Furnished	287GGFJP-3 (20)	360 C	Eng	126				Furnished
287GGFJP-8 (20)	360 C	Eng	117				Furnished	287GGFJP-3 (20)	360 C	Eng	117				Furnished
287GKFJP-5 (21)	340 C	Eng	140				Furnished	287GKFJP-3 (21)	340 C	Eng	140				Furnished
287GMFJP-5 (22)	309 C	Eng	157				Furnished	287GMFJP-3 (22)	309 C	Eng	157				Furnished
287GMFJP-8 (22)	318 C	Eng	145				Furnished	287GMFJP-3 (22)	318 C	Eng	145				Furnished
287GPFJP-5 (23)	275 C	Eng	175				Furnished	287GPFJP-3 (23)	275 C	Eng	175				Furnished
287GPFJP-8 (23)	290 C	Eng	162				Furnished	287GPFJP-3 (23)	290 C	Eng	162				Furnished
287GSFJP-5 (24)	247 C	Eng	196				Furnished	287GSFJP-3 (24)	247 C	Eng	196				Furnished
287GSFJP-8 (24)	265 C	Eng	180				Furnished	287GSFJP-3 (24)	265 C	Eng	180				Furnished
287GTFJP-8 (16)	230 C	Eng	211				Furnished	287GTFJP-3 (16)	230 C	Eng	211				Furnished
877XAFJP-5 (7)	485 C	Eng	100				Furnished	877XAFJP-3 (7)	485 C	Eng	100				Furnished
877XBFJP-5 (8)	458 C	Eng	106				Furnished	877XBFJP-3 (8)	458 C	Eng	106				Furnished
877XCFJP-5 (9)	425 C	Eng	114				Furnished	877XCFJP-3 (9)	425 C	Eng	114				Furnished
877XDFJP-5 (10)	401 C	Eng	121				Furnished	877XDFJP-3 (10)	401 C	Eng	121				Furnished
877XEFJP-5 (11)	351 C	Eng	138				Furnished	877XEFJP-3 (11)	351 C	Eng	138				Furnished
877XFFJP-5 (12)	311 C	Eng	158				Furnished	877XFFJP-3 (12)	311 C	Eng	158				Furnished

Continued on Next Page

† I = Intermittent Torque Only - De-rate Torque Rating 30% for Continuous Duty.

C = Continuous or Intermittent Torque - No need to De-Rate Torque Rating.

IMPORTANT: Refer to the back of this transmission section and read all notes associated with this application page. Some notes may affect the proper PTO selection.

CAUTION: Chelsea Recommends the Power Take-Off (PTO) installation on the 3000/4000 Series Transmissions to utilize a Vehicle Interface Module, or Chassis Manufacturer's equivalent controller to incorporate all the PTO control features available, this includes the "PTO Request" and "PTO Enable Output" feature. The "PTO Enable" circuit signals the Transmission Control Module (TCM) to maintain line pressure to the PTO. Failure to provide this signal may not be sufficient to the PTO. This may cause damage to the PTO and /or Transmission. Please see the Allison Transmission website and individual chassis manufacturer for installation details.

CAUTION: The torque values given for specific application pages may be limited to the rated torque of the Allison transmission.

- (1) Input Gear Part No. 5-P-1173
- (2) Input Gear Part No. 5-P-1225
- (3) Input Gear Part No. 5-P-1293
- (4) Input Gear Part No. 5-P-1350
- (5) Input Gear Part No. 5-P-1351
- (7) Input Gear Part No. 5-P-1428-11X

- (8) Input Gear Part No. 5-P-1428-12X
- (9) Input Gear Part No. 5-P-1428-3X
- (10) Input Gear Part No. 5-P-1428-4X
- (11) Input Gear Part No. 5-P-1428-5X
- (12) Input Gear Part No. 5-P-1428-6X
- (16) Input Gear Part No. 5-P-1491-10X

- (17) Input Gear Part No. 5-P-1491-1X
- (18) Input Gear Part No. 5-P-1491-2X
- (19) Input Gear Part No. 5-P-1491-3X
- (20) Input Gear Part No. 5-P-1491-4X
- (21) Input Gear Part No. 5-P-1491-5X
- (22) Input Gear Part No. 5-P-1491-6X

- (23) Input Gear Part No. 5-P-1491-7X
- (24) Input Gear Part No. 5-P-1491-8X
- (25) Input Gear Part No. 5-P-912
- (26) Input Gear Part No. 5-P-913
- (27) Input Gear Part No. 5-P-914
- (28) Input Gear Part No. 5-P-915

ALL-16R

ALLISON

CHELSEA®

3000 (3000 Family - Side/Top PTO Provision w/ Retarder)

LEFT SIDE ONLY

TOP SIDE ONLY

TRANSMISSION GEAR DATA:

L.S. 10-BOLT Opening Gear FORWARD of Centerline
83 Teeth - L.H. HELIX

PITCH LINE TO APERTURE FACE:

1.7800" (45.2100MM)

TRANSMISSION GEAR DATA:

TOP 10-BOLT Opening Gear FORWARD of Centerline
83 Teeth - L.H. HELIX

PITCH LINE TO APERTURE FACE:

1.7800" (45.2100MM)

CAUTION: Application Approval Required for PTO Output Shaft Speeds Above 2500 RPM

PTO Model	Torq	Dir Rot	Engine %		Filler Block	Adapter Assy	Stud Kit	PTO Model	Torq	Dir Rot	Engine %		Filler Block	Adapter Assy	Stud Kit
	I / C †		Fwd	Rev					I / C †		Fwd	Rev			

ONE SPEED - TWO GEAR - CONSTANT MESH

877XGFJP-*5 (13)	274 C	Eng	177			Furnished	877XGFJP-*3 (13)	274 C	Eng	177					Furnished
877XHFJP-*5 (14)	258 C	Eng	188			Furnished	877XHFJP-*3 (14)	258 C	Eng	188					Furnished
877XJFJP-*5 (15)	242 C	Eng	200			Furnished	877XJFJP-*3 (15)	242 C	Eng	200					Furnished
877XKFJP-*5 (6)	292 C	Eng	166			Furnished	877XKFJP-*3 (6)	292 C	Eng	166					Furnished

ONE SPEED - TWO GEAR - POWERSHIFT (HYDRAULIC)

280GBFJP-*5 (17)	300 C	Eng	73			Furnished	280GBFJP-*3 (17)	300 C	Eng	73					Furnished
280GBFJP-*8 (17)	300 C	Eng	69			Furnished	280GBFJP-*8 (17)	300 C	Eng	69					Furnished
280GCFJP-*5 (18)	390 C	Eng	88			Furnished	280GCFJP-*3 (18)	390 C	Eng	88					Furnished
280GCFJP-*8 (18)	390 C	Eng	83			Furnished	280GCFJP-*8 (18)	390 C	Eng	83					Furnished
280GDFJP-*5 (19)	390 C	Eng	106			Furnished	280GDFJP-*3 (19)	390 C	Eng	106					Furnished
280GDFJP-*8 (19)	390 C	Eng	99			Furnished	280GDFJP-*8 (19)	390 C	Eng	99					Furnished
280GGFJP-*5 (20)	360 C	Eng	126			Furnished	280GGFJP-*3 (20)	360 C	Eng	126					Furnished
280GGFJP-*8 (20)	360 C	Eng	117			Furnished	280GGFJP-*8 (20)	360 C	Eng	117					Furnished
280GKFJP-*5 (21)	340 C	Eng	140			Furnished	280GKFJP-*3 (21)	340 C	Eng	140					Furnished
280GMFJP-*5 (22)	309 C	Eng	157			Furnished	280GMFJP-*3 (22)	309 C	Eng	157					Furnished
280GMFJP-*8 (22)	318 C	Eng	145			Furnished	280GMFJP-*8 (22)	318 C	Eng	145					Furnished
280GPFJP-*5 (23)	275 C	Eng	175			Furnished	280GPFJP-*3 (23)	275 C	Eng	175					Furnished
280GPFJP-*8 (23)	290 C	Eng	162			Furnished	280GPFJP-*8 (23)	290 C	Eng	162					Furnished
280GSFJP-*5 (24)	247 C	Eng	196			Furnished	280GSFJP-*3 (24)	247 C	Eng	196					Furnished
280GSFJP-*8 (24)	265 C	Eng	180			Furnished	280GSFJP-*8 (24)	265 C	Eng	180					Furnished
870XAFJP-*5 (7)	485 C	Eng	100			Furnished	870XAFJP-*3 (7)	485 C	Eng	100					Furnished
870XBFJP-*5 (8)	458 C	Eng	106			Furnished	870XBFJP-*3 (8)	458 C	Eng	106					Furnished
870XCFJP-*5 (9)	425 C	Eng	114			Furnished	870XCFJP-*3 (9)	425 C	Eng	114					Furnished
870XDFJP-*5 (10)	401 C	Eng	121			Furnished	870XDFJP-*3 (10)	401 C	Eng	121					Furnished
870XEFJP-*5 (11)	351 C	Eng	138			Furnished	870XEFJP-*3 (11)	351 C	Eng	138					Furnished
870XFFJP-*5 (12)	311 C	Eng	156			Furnished	870XFFJP-*3 (12)	311 C	Eng	156					Furnished
870XGFJP-*5 (13)	274 C	Eng	177			Furnished	870XGFJP-*3 (13)	274 C	Eng	177					Furnished
870XHFJP-*5 (14)	258 C	Eng	188			Furnished	870XHFJP-*3 (14)	258 C	Eng	188					Furnished
870XJFJP-*5 (15)	242 C	Eng	200			Furnished	870XJFJP-*3 (15)	242 C	Eng	200					Furnished

Continued on Next Page

† I = Intermittent Torque Only - De-rate Torque Rating 30% for Continuous Duty.

C = Continuous or Intermittent Torque - No need to De-Rate Torque Rating.

IMPORTANT: Refer to the back of this transmission section and read all notes associated with this application page. Some notes may affect the proper PTO selection.

CAUTION: Chelsea Recommends the Power Take-Off (PTO) installation on the 3000/4000 Series Transmissions to utilize a Vehicle Interface Module, or Chassis Manufacturer's equivalent controller to incorporate all the PTO control features available, this includes the "PTO Request" and "PTO Enable Output" feature. The "PTO Enable" circuit signals the Transmission Control Module (TCM) to maintain line pressure to the PTO. Failure to provide this signal may not be sufficient to the PTO. This may cause damage to the PTO and /or Transmission. Please see the Allison Transmission website and individual chassis manufacturer for installation details.

CAUTION: The torque values given for specific application pages may be limited to the rated torque of the Allison transmission.

- | | | |
|--------------------------------------|--------------------------------------|--------------------------------------|
| (6) Input Gear Part No. 5-P-1428-10X | (12) Input Gear Part No. 5-P-1428-6X | (19) Input Gear Part No. 5-P-1491-3X |
| (7) Input Gear Part No. 5-P-1428-11X | (13) Input Gear Part No. 5-P-1428-7X | (20) Input Gear Part No. 5-P-1491-4X |
| (8) Input Gear Part No. 5-P-1428-12X | (14) Input Gear Part No. 5-P-1428-8X | (21) Input Gear Part No. 5-P-1491-5X |
| (9) Input Gear Part No. 5-P-1428-3X | (15) Input Gear Part No. 5-P-1428-9X | (22) Input Gear Part No. 5-P-1491-6X |
| (10) Input Gear Part No. 5-P-1428-4X | (17) Input Gear Part No. 5-P-1491-1X | (23) Input Gear Part No. 5-P-1491-7X |
| (11) Input Gear Part No. 5-P-1428-5X | (18) Input Gear Part No. 5-P-1491-2X | (24) Input Gear Part No. 5-P-1491-8X |

Allison



October 2022
5.2.50

Parker Hannifin Corporation
Chelsea Products Division
Olive Branch, MS 38654 USA

CHELSEA®

ALLISON

ALL-16R

3000 (3000 Family - Side/Top PTO Provision w/ Retarder)

LEFT SIDE ONLY

TOP SIDE ONLY

TRANSMISSION GEAR DATA:

L.S. 10-BOLT Opening Gear FORWARD of Centerline
83 Teeth - L.H. HELIX

PITCH LINE TO APERTURE FACE:

1.7800" (45.2100MM)

TRANSMISSION GEAR DATA:

TOP 10-BOLT Opening Gear FORWARD of Centerline
83 Teeth - L.H. HELIX

PITCH LINE TO APERTURE FACE:

1.7800" (45.2100MM)

CAUTION: Application Approval Required for PTO Output Shaft Speeds Above 2500 RPM

PTO Model	Torq I / C †	Dir Rot	Engine %		Filler Block	Adapter Assy	Stud Kit	PTO Model	Torq I / C †	Dir Rot	Engine %		Filler Block	Adapter Assy	Stud Kit
			Fwd	Rev							Fwd	Rev			

ONE SPEED - POWERSHIFT (HYDRAULIC) EXTENDED SHAFT

870LAFJW-*5 (7)	485 C	Eng	100				Furnished								
870LBFJW-*5 (8)	458 C	Eng	106				Furnished								
870LCFJW-*5 (9)	425 C	Eng	114				Furnished								
870LDFJW-*5 (10)	401 C	Eng	121				Furnished								
870LEFJW-*5 (11)	351 C	Eng	138				Furnished								
870LFFJW-*5 (12)	311 C	Eng	156				Furnished								
870LGFJW-*5 (13)	274 C	Eng	177				Furnished								
870LHFJW-*5 (14)	258 C	Eng	188				Furnished								
890FAFJW-*5 (7)	485 C	Eng	100				Furnished								
890FBFJW-*5 (8)	458 C	Eng	106				Furnished								
890FCFJW-*5 (9)	425 C	Eng	114				Furnished								
890FDJW-*5 (10)	401 C	Eng	121				Furnished								
890FEFJW-*5 (11)	351 C	Eng	138				Furnished								
890FFFJW-*5 (12)	311 C	Eng	156				Furnished								
890FGFJW-*5 (13)	274 C	Eng	177				Furnished								
890FHFJW-*5 (14)	258 C	Eng	188				Furnished								

ONE SPEED - CONSTANT MESH EXTENDED SHAFT

877LAFJW-*5 (7)	485 C	Eng	100				Furnished								
877LBFJW-*5 (8)	458 C	Eng	106				Furnished								
877LCFJW-*5 (9)	425 C	Eng	114				Furnished								
877LDFJW-*5 (10)	401 C	Eng	121				Furnished								
877LEFJW-*5 (11)	351 C	Eng	138				Furnished								
877LFFJW-*5 (12)	311 C	Eng	156				Furnished								
877LGFJW-*5 (13)	274 C	Eng	177				Furnished								
877LHFJW-*5 (14)	258 C	Eng	188				Furnished								
897FAFJW-*5 (7)	485 C	Eng	100				Furnished								
897FBFJW-*5 (8)	458 C	Eng	106				Furnished								
897FCFJW-*5 (9)	425 C	Eng	114				Furnished								
897FDJW-*5 (10)	401 C	Eng	121				Furnished								
897FEFJW-*5 (11)	351 C	Eng	138				Furnished								
897FFFJW-*5 (12)	311 C	Eng	156				Furnished								

Continued on Next Page

† I = Intermittent Torque Only - De-rate Torque Rating 30% for Continuous Duty.

C = Continuous or Intermittent Torque - No need to De-Rate Torque Rating.

IMPORTANT: Refer to the back of this transmission section and read all notes associated with this application page. Some notes may affect the proper PTO selection.

CAUTION: Chelsea Recommends the Power Take-Off (PTO) installation on the 3000/4000 Series Transmissions to utilize a Vehicle Interface Module, or Chassis Manufacturer's equivalent controller to incorporate all the PTO control features available, this includes the "PTO Request" and "PTO Enable Output" feature. The "PTO Enable" circuit signals the Transmission Control Module (TCM) to maintain line pressure to the PTO. Failure to provide this signal may not be sufficient to the PTO. This may cause damage to the PTO and /or Transmission. Please see the Allison Transmission website and individual chassis manufacturer for installation details.

CAUTION: The torque values given for specific application pages may be limited to the rated torque of the Allison transmission.

(7) Input Gear Part No. 5-P-1428-11X

(13) Input Gear Part No. 5-P-1428-7X

(8) Input Gear Part No. 5-P-1428-12X

(14) Input Gear Part No. 5-P-1428-8X

(9) Input Gear Part No. 5-P-1428-3X

(10) Input Gear Part No. 5-P-1428-4X

(11) Input Gear Part No. 5-P-1428-5X

(12) Input Gear Part No. 5-P-1428-6X

ALL-16R

ALLISON

CHELSEA®

3000 (3000 Family - Side/Top PTO Provision w/ Retarder)

LEFT SIDE ONLY

TOP SIDE ONLY

TRANSMISSION GEAR DATA:L.S. 10-BOLT Opening Gear FORWARD of Centerline
83 Teeth - L.H. HELIX**PITCH LINE TO APERTURE FACE:**

1.7800" (45.2100MM)

TRANSMISSION GEAR DATA:TOP 10-BOLT Opening Gear FORWARD of Centerline
83 Teeth - L.H. HELIX**PITCH LINE TO APERTURE FACE:**

1.7800" (45.2100MM)

CAUTION: Application Approval Required for PTO Output Shaft Speeds Above 2500 RPM

PTO Model	Torq	Dir Rot	Engine %		Filler Block	Adapter Assy	Stud Kit	PTO Model	Torq	Dir Rot	Engine %		Filler Block	Adapter Assy	Stud Kit
	I / C †		Fwd	Rev					I / C †		Fwd	Rev			

ONE SPEED - CONSTANT MESH EXTENDED SHAFT

897FGFJW-*5 (13)	274 C	Eng	177				Furnished
897FHFJW-*5 (14)	258 C	Eng	188				Furnished

† I = Intermittent Torque Only - De-rate Torque Rating 30% for Continuous Duty.

C = Continuous or Intermittent Torque - No need to De-Rate Torque Rating.

IMPORTANT: Refer to the back of this transmission section and read all notes associated with this application page. Some notes may affect the proper PTO selection.

CAUTION: Chelsea Recommends the Power Take-Off (PTO) installation on the 3000/4000 Series Transmissions to utilize a Vehicle Interface Module, or Chassis Manufacturer's equivalent controller to incorporate all the PTO control features available, this includes the "PTO Request" and "PTO Enable Output" feature. The "PTO Enable" circuit signals the Transmission Control Module (TCM) to maintain line pressure to the PTO. Failure to provide this signal may not be sufficient to the PTO. This may cause damage to the PTO and /or Transmission. Please see the Allison Transmission website and individual chassis manufacturer for installation details.

CAUTION: The torque values given for specific application pages may be limited to the rated torque of the Allison transmission.

(13) Input Gear Part No. 5-P-1428-7X
(14) Input Gear Part No. 5-P-1428-8X

Allison

1000 (GM 3600 Cab-Chassis)

RIGHT SIDE ONLY

TRANSMISSION GEAR DATA:

R.S. 06-BOLT Opening Gear FORWARD of Centerline
64 Teeth - SPUR

PITCH LINE TO APERTURE FACE:

1.0080" (25.6032MM)

CAUTION: Application Approval Required for PTO Output Shaft Speeds Above 2500 RPM

PTO Model	Torq	Dir Rot	Engine %		Filler Block	Adapter Assy	Stud Kit	PTO Model	Torq	Dir Rot	Engine %		Filler Block	Adapter Assy	Stud Kit
	I / C †		Fwd	Rev					I / C †		Fwd	Rev			

ONE SPEED - TWO GEAR - POWERSHIFT (HYDRAULIC)

252GDHVX-*5 (1) 120 l Eng 122
252GMHVX-*5 (2) 50 l Eng 178

Furnished
Furnished

Pump Option Charts

252 Pumps offered in the PGP511 (5/8" - 9T / SAE A Flange – XE Output)

Option Order Code	Chelsea Pump Model	Displacement in ³ /rev	Displacement Gal/rev	Max Pressure PSI	Max Speed RPM	Shaft Size	Porting	
							Inlet	Outlet
1116	CGP-P11C016-1AC	0.37	0.003	3988	3500	5/8" - 9T	SAE12	SAE10
1121	CGP-P11C021-1AC	0.49	0.002	3988	4000	5/8" - 9T	SAE12	SAE10
1126	CGP-P11C026-1AC	0.61	0.003	3988	3600	5/8" - 9T	SAE12	SAE10
1129	CGP-P11C029-1AC	0.67	0.003	3988	3600	5/8" - 9T	SAE12	SAE10
1137	CGP-P11C037-1AC	0.85	0.004	3988	3300	5/8" - 9T	SAE12	SAE10
1449	CGP-P31C054-1AE	1.24	0.005	3500	3000	5/8" - 9T	SAE16	SAE10
1462	CGP-P31C061-1AE	1.40	0.006	3500	3000	5/8" - 9T	SAE16	SAE10

252 Pumps offered in the PGP511 (3/4" - 11T / SAE A Flange – AD Output)

Option Order Code	Chelsea Pump Model	Displacement in ³ /rev	Displacement Gal/rev	Max Pressure PSI	Max Speed RPM	Shaft Size	Porting	
							Inlet	Outlet
P37	CGP-P11C037-5AC	0.85	0.004	3988	3300	3/4" - 11T	SAE12	SAE10
P42	CGP-P11C042-5AC	0.98	0.004	3988	3000	3/4" - 11T	SAE12	SAE10
P55	CGP-P11C055-5AC	1.28	0.006	3408	2800	3/4" - 11T	SAE12	SAE10
P71	CGP-P11C071-5AC	1.65	0.007	2900	2400	3/4" - 11T	SAE12	SAE10
P82	CGP-P11C082-5AC	1.89	0.008	2465	2300	3/4" - 11T	SAE12	SAE10

† I = Intermittent Torque Only - De-rate Torque Rating 30% for Continuous Duty.

C = Continuous or Intermittent Torque - No need to De-Rate Torque Rating.

IMPORTANT: Refer to the back of this transmission section and read all notes associated with this application page. Some notes may affect the proper PTO selection.

CAUTION: The "PTO Enable" circuit signals the Transmission Control Module (TCM) to maintain line pressure to the PTO. Failure to provide this signal will activate the Variable Modulated Main Pressure and line pressure may not be sufficient to the PTO. This may cause damage to the PTO and/or Transmission.

(1) Input Gear Part No. 5-P-1294
(2) Input Gear Part No. 5-P-1386

ALL-18

ALLISON

CHELSEA®

3700
3700 SP
MD-3070P (Close Ratio)

LEFT SIDE ONLY

RIGHT SIDE ONLY

TRANSMISSION GEAR DATA:

L.S. 10-BOLT Opening Gear FORWARD of Centerline
68 Teeth - L.H. HELIX

PITCH LINE TO APERTURE FACE:

1.7800" (45.2100MM)

TRANSMISSION GEAR DATA:

R.S. 10-BOLT Opening Gear FORWARD of Centerline
68 Teeth - L.H. HELIX

PITCH LINE TO APERTURE FACE:

1.7800" (45.2100MM)

CAUTION: Application Approval Required for PTO Output Shaft Speeds Above 2500 RPM

PTO Model	Torq l / C †	Dir Rot	Engine %		Filler Block	Adapter Assy	Stud Kit	PTO Model	Torq l / C †	Dir Rot	Engine %		Filler Block	Adapter Assy	Stud Kit
			Fwd	Rev							Fwd	Rev			

ONE SPEED - TWO GEAR - CONSTANT MESH

267SBFJP-5 (4)	402 l	Eng	72				Furnished	267SBFJP-3 (4)	402 l	Eng	72				Furnished
267SDFJP-5 (3)	390 l	Eng	87				Furnished	267SDFJP-3 (3)	390 l	Eng	87				Furnished
267SGFJP-5 (2)	360 l	Eng	103				Furnished	267SGFJP-3 (2)	360 l	Eng	103				Furnished
267SMFJP-5 (5)	318 l	Eng	129				Furnished	267SMFJP-3 (5)	318 l	Eng	129				Furnished
267SSFJP-5 (1)	265 l	Eng	161				Furnished	267SSFJP-3 (1)	265 l	Eng	161				Furnished
267XBFJP-5 (25)	335 l	Eng	72				Furnished	267XBFJP-3 (25)	335 l	Eng	72				Furnished
267XDFJP-5 (26)	325 l	Eng	87				Furnished	267XDFJP-3 (26)	325 l	Eng	87				Furnished
267XGFJP-5 (27)	300 l	Eng	103				Furnished	267XGFJP-3 (27)	300 l	Eng	103				Furnished
267XMFJP-5 (28)	265 l	Eng	129				Furnished	267XMFJP-3 (28)	265 l	Eng	129				Furnished
267XSFJP-5 (1)	250 l	Eng	161				Furnished	267XSFJP-3 (1)	250 l	Eng	161				Furnished
287GBFJP-5 (16)	300 C	Eng	60				Furnished	287GBFJP-3 (16)	300 C	Eng	60				Furnished
287GBFJP-8 (16)	300 C	Eng	56				Furnished	287GBFJP-8 (16)	300 C	Eng	56				Furnished
287GCFJP-5 (17)	390 C	Eng	72				Furnished	287GCFJP-3 (17)	390 C	Eng	72				Furnished
287GCFJP-8 (17)	390 C	Eng	68				Furnished	287GCFJP-8 (17)	390 C	Eng	68				Furnished
287GDFJP-5 (18)	390 C	Eng	87				Furnished	287GDFJP-3 (18)	390 C	Eng	87				Furnished
287GDFJP-8 (18)	390 C	Eng	81				Furnished	287GDFJP-8 (18)	390 C	Eng	81				Furnished
287GGFJP-5 (19)	360 C	Eng	103				Furnished	287GGFJP-3 (19)	360 C	Eng	103				Furnished
287GGFJP-8 (19)	360 C	Eng	96				Furnished	287GGFJP-8 (19)	360 C	Eng	96				Furnished
287GKFJP-5 (20)	340 C	Eng	115				Furnished	287GKFJP-3 (20)	340 C	Eng	115				Furnished
287GMFJP-5 (21)	318 C	Eng	129				Furnished	287GMFJP-3 (21)	318 C	Eng	129				Furnished
287GMFJP-8 (21)	318 C	Eng	119				Furnished	287GMFJP-8 (21)	318 C	Eng	119				Furnished
287GPFJP-5 (22)	290 C	Eng	144				Furnished	287GPFJP-3 (22)	290 C	Eng	144				Furnished
287GPFJP-8 (22)	290 C	Eng	132				Furnished	287GPFJP-8 (22)	290 C	Eng	132				Furnished
287GSFJP-5 (23)	265 C	Eng	161				Furnished	287GSFJP-3 (23)	265 C	Eng	161				Furnished
287GSFJP-8 (23)	265 C	Eng	147				Furnished	287GSFJP-8 (23)	265 C	Eng	147				Furnished
287GTFJP-5 (24)	240 C	Eng	180				Furnished	287GTFJP-3 (24)	240 C	Eng	180				Furnished
287GTFJP-8 (15)	240 C	Eng	173				Furnished	287GTFJP-8 (15)	240 C	Eng	173				Furnished
877XAFJP-5 (6)	591 C	Eng	82				Furnished	877XAFJP-3 (6)	591 C	Eng	82				Furnished
877XBFJP-5 (7)	557 C	Eng	87				Furnished	877XBFJP-3 (7)	557 C	Eng	87				Furnished
877XCFJP-5 (8)	522 C	Eng	93				Furnished	877XCFJP-3 (8)	522 C	Eng	93				Furnished
877XDFJP-5 (9)	490 C	Eng	99				Furnished	877XDFJP-3 (9)	490 C	Eng	99				Furnished
877XEFJP-5 (10)	429 C	Eng	113				Furnished	877XEFJP-3 (10)	429 C	Eng	113				Furnished

Continued on Next Page

† I = Intermittent Torque Only - De-rate Torque Rating 30% for Continuous Duty.

C = Continuous or Intermittent Torque - No need to De-Rate Torque Rating.

IMPORTANT: Refer to the back of this transmission section and read all notes associated with this application page. Some notes may affect the proper PTO selection.

CAUTION: Chelsea Recommends the Power Take-Off (PTO) installation on the 3000/4000 Series Transmissions to utilize a Vehicle Interface Module, or Chassis Manufacturer's equivalent controller to incorporate all the PTO control features available, this includes the "PTO Request" and "PTO Enable Output" feature. The "PTO Enable" circuit signals the Transmission Control Module (TCM) to maintain line pressure to the PTO. Failure to provide this signal may not be sufficient to the PTO. This may cause damage to the PTO and /or Transmission. Please see the Allison Transmission website and individual chassis manufacturer for installation details.

CAUTION: The torque values given for specific application pages may be limited to the rated torque of the Allison transmission.

- | | | | |
|--------------------------------------|---------------------------------------|--------------------------------------|--------------------------------------|
| (1) Input Gear Part No. 5-P-1173 | (7) Input Gear Part No. 5-P-1428-12X | (17) Input Gear Part No. 5-P-1491-2X | (23) Input Gear Part No. 5-P-1491-8X |
| (2) Input Gear Part No. 5-P-1225 | (8) Input Gear Part No. 5-P-1428-3X | (18) Input Gear Part No. 5-P-1491-3X | (24) Input Gear Part No. 5-P-1491-9X |
| (3) Input Gear Part No. 5-P-1293 | (9) Input Gear Part No. 5-P-1428-4X | (19) Input Gear Part No. 5-P-1491-4X | (25) Input Gear Part No. 5-P-912 |
| (4) Input Gear Part No. 5-P-1350 | (10) Input Gear Part No. 5-P-1428-5X | (20) Input Gear Part No. 5-P-1491-5X | (26) Input Gear Part No. 5-P-913 |
| (5) Input Gear Part No. 5-P-1351 | (11) Input Gear Part No. 5-P-1491-10X | (21) Input Gear Part No. 5-P-1491-6X | (27) Input Gear Part No. 5-P-914 |
| (6) Input Gear Part No. 5-P-1428-11X | (16) Input Gear Part No. 5-P-1491-1X | (22) Input Gear Part No. 5-P-1491-7X | (28) Input Gear Part No. 5-P-915 |

Allison



October 2022
5.2.54

Parker Hannifin Corporation
Chelsea Products Division
Olive Branch, MS 38654 USA

CHELSEA®

ALLISON

ALL-18

3700
3700 SP
MD-3070P (Close Ratio)

LEFT SIDE ONLY

RIGHT SIDE ONLY

TRANSMISSION GEAR DATA:

L.S. 10-BOLT Opening Gear FORWARD of Centerline
68 Teeth - L.H. HELIX

PITCH LINE TO APERTURE FACE:

1.7800" (45.2100MM)

TRANSMISSION GEAR DATA:

R.S. 10-BOLT Opening Gear FORWARD of Centerline
68 Teeth - L.H. HELIX

PITCH LINE TO APERTURE FACE:

1.7800" (45.2100MM)

CAUTION: Application Approval Required for PTO Output Shaft Speeds Above 2500 RPM

PTO Model	Torq I / C †	Dir Rot	Engine %		Filler Block	Adapter Assy	Stud Kit	PTO Model	Torq I / C †	Dir Rot	Engine %		Filler Block	Adapter Assy	Stud Kit
			Fwd	Rev							Fwd	Rev			

ONE SPEED - TWO GEAR - CONSTANT MESH

877XFFJP-*5 (11)	379 C	Eng	128				Furnished	877XFFJP-*3 (11)	379 C	Eng	128				Furnished
877XGFJP-*5 (12)	334 C	Eng	145				Furnished	877XGFJP-*3 (12)	334 C	Eng	145				Furnished
877XHFJP-*5 (13)	315 C	Eng	154				Furnished	877XHFJP-*3 (13)	315 C	Eng	154				Furnished
877XJFJP-*5 (14)	295 C	Eng	164				Furnished	877XJFJP-*3 (14)	295 C	Eng	164				Furnished

ONE SPEED - TWO GEAR - POWERSHIFT (HYDRAULIC)

280GBFJP-*5 (16)	300 C	Eng	60				Furnished	280GBFJP-*3 (16)	300 C	Eng	60				Furnished
280GBFJP-*8 (16)	300 C	Eng	56				Furnished	280GBFJP-*8 (16)	300 C	Eng	56				Furnished
280GCFJP-*5 (17)	390 C	Eng	72				Furnished	280GCFJP-*3 (17)	390 C	Eng	72				Furnished
280GCFJP-*8 (17)	390 C	Eng	68				Furnished	280GCFJP-*8 (17)	390 C	Eng	68				Furnished
280GDFJP-*5 (18)	390 C	Eng	87				Furnished	280GDFJP-*3 (18)	390 C	Eng	87				Furnished
280GDFJP-*8 (18)	390 C	Eng	81				Furnished	280GDFJP-*8 (18)	390 C	Eng	81				Furnished
280GGFJP-*5 (19)	360 C	Eng	103				Furnished	280GGFJP-*3 (19)	360 C	Eng	103				Furnished
280GGFJP-*8 (19)	360 C	Eng	96				Furnished	280GGFJP-*8 (19)	360 C	Eng	96				Furnished
280GKFJP-*5 (20)	340 C	Eng	115				Furnished	280GKFJP-*3 (20)	340 C	Eng	115				Furnished
280GMFJP-*5 (21)	318 C	Eng	129				Furnished	280GMFJP-*3 (21)	318 C	Eng	129				Furnished
280GMFJP-*8 (21)	318 C	Eng	119				Furnished	280GMFJP-*8 (21)	318 C	Eng	119				Furnished
280GPFJP-*5 (22)	290 C	Eng	144				Furnished	280GPFJP-*3 (22)	290 C	Eng	144				Furnished
280GPFJP-*8 (22)	290 C	Eng	132				Furnished	280GPFJP-*8 (22)	290 C	Eng	132				Furnished
280GSFJP-*5 (23)	265 C	Eng	161				Furnished	280GSFJP-*3 (23)	265 C	Eng	161				Furnished
280GSFJP-*8 (23)	265 C	Eng	147				Furnished	280GSFJP-*8 (23)	265 C	Eng	147				Furnished
280GTFJP-*5 (24)	240 C	Eng	180				Furnished	280GTFJP-*3 (24)	240 C	Eng	180				Furnished
280GTFJP-*8 (15)	240 C	Eng	173				Furnished	280GTFJP-*8 (15)	240 C	Eng	173				Furnished
870XAFJP-*5 (6)	591 C	Eng	82				Furnished	870XAFJP-*3 (6)	591 C	Eng	82				Furnished
870XBFJP-*5 (7)	557 C	Eng	87				Furnished	870XBFJP-*3 (7)	557 C	Eng	87				Furnished
870XCFJP-*5 (8)	522 C	Eng	93				Furnished	870XCFJP-*3 (8)	522 C	Eng	93				Furnished
870XDFJP-*5 (9)	490 C	Eng	99				Furnished	870XDFJP-*3 (9)	490 C	Eng	99				Furnished
870XEFJP-*5 (10)	429 C	Eng	113				Furnished	870XEFJP-*3 (10)	429 C	Eng	113				Furnished
870XFFJP-*5 (11)	379 C	Eng	128				Furnished	870XFFJP-*3 (11)	379 C	Eng	128				Furnished
870XGFJP-*5 (12)	334 C	Eng	145				Furnished	870XGFJP-*3 (12)	334 C	Eng	145				Furnished
870XHFJP-*5 (13)	315 C	Eng	154				Furnished	870XHFJP-*3 (13)	315 C	Eng	154				Furnished
870XJFJP-*5 (14)	295 C	Eng	164				Furnished	870XJFJP-*3 (14)	295 C	Eng	164				Furnished

† I = Intermittent Torque Only - De-rate Torque Rating 30% for Continuous Duty.

C = Continuous or Intermittent Torque - No need to De-Rate Torque Rating.

IMPORTANT: Refer to the back of this transmission section and read all notes associated with this application page. Some notes may affect the proper PTO selection.

CAUTION: Chelsea Recommends the Power Take-Off (PTO) installation on the 3000/4000 Series Transmissions to utilize a Vehicle Interface Module, or Chassis Manufacturer's equivalent controller to incorporate all the PTO control features available, this includes the "PTO Request" and "PTO Enable Output" feature. The "PTO Enable" circuit signals the Transmission Control Module (TCM) to maintain line pressure to the PTO. Failure to provide this signal may not be sufficient to the PTO. This may cause damage to the PTO and /or Transmission. Please see the Allison Transmission website and individual chassis manufacturer for installation details.

CAUTION: The torque values given for specific application pages may be limited to the rated torque of the Allison transmission.

(6) Input Gear Part No. 5-P-1428-11X
(7) Input Gear Part No. 5-P-1428-12X
(8) Input Gear Part No. 5-P-1428-3X
(9) Input Gear Part No. 5-P-1428-4X
(10) Input Gear Part No. 5-P-1428-5X
(11) Input Gear Part No. 5-P-1428-6X

(12) Input Gear Part No. 5-P-1428-7X
(13) Input Gear Part No. 5-P-1428-8X
(14) Input Gear Part No. 5-P-1428-9X
(15) Input Gear Part No. 5-P-1491-10X
(16) Input Gear Part No. 5-P-1491-1X
(17) Input Gear Part No. 5-P-1491-2X

(18) Input Gear Part No. 5-P-1491-3X
(19) Input Gear Part No. 5-P-1491-4X
(20) Input Gear Part No. 5-P-1491-5X
(21) Input Gear Part No. 5-P-1491-6X
(22) Input Gear Part No. 5-P-1491-7X
(23) Input Gear Part No. 5-P-1491-8X

(24) Input Gear Part No. 5-P-1491-9X

ALL-19

ALLISON

CHELSEA®

4700 4700 EVS 4700 OFS 4700 RDS 4700 SP 4800 4800 EVS 4800 SP	4850 EVS
--	----------

LEFT SIDE ONLY	TOP SIDE ONLY
TRANSMISSION GEAR DATA: L.S. 10-BOLT Opening Gear FORWARD of Centerline 97 Teeth - L.H. HELIX PITCH LINE TO APERTURE FACE: 1.7799" (45.2100MM)	TRANSMISSION GEAR DATA: TOP 10-BOLT Opening Gear FORWARD of Centerline 97 Teeth - L.H. HELIX PITCH LINE TO APERTURE FACE: 1.7799" (45.2100MM)

CAUTION: Application Approval Required for PTO Output Shaft Speeds Above 2500 RPM

PTO Model	Torq I / C †	Dir Rot	Engine %		Filler Block	Adapter Assy	Stud Kit	PTO Model	Torq I / C †	Dir Rot	Engine %		Filler Block	Adapter Assy	Stud Kit
			Fwd	Rev							Fwd	Rev			

ONE SPEED - TWO GEAR - CONSTANT MESH

267SBFJP-*5 (4)	402 I	Eng	103				Furnished	267SBFJP-*3 (4)	402 I	Eng	103				Furnished
267SDFJP-*5 (3)	390 I	Eng	123				Furnished	267SDFJP-*3 (4)	390 I	Eng	123				Furnished
267SGFJP-*5 (2)	360 I	Eng	147				Furnished	267SGFJP-*3 (2)	360 I	Eng	147				Furnished
267SMFJP-*5 (5)	318 I	Eng	184				Furnished	267SMFJP-*3 (5)	318 I	Eng	184				Furnished
267SSFJP-*5 (1)	265 I	Eng	229				Furnished	267SSFJP-*3 (1)	265 I	Eng	229				Furnished
267XBFJP-*5 (20)	335 I	Eng	103				Furnished	267XBFJP-*3 (20)	335 I	Eng	103				Furnished
267XDFJP-*5 (21)	325 I	Eng	123				Furnished	267XDFJP-*3 (21)	325 I	Eng	123				Furnished
267XGFJP-*5 (22)	300 I	Eng	147				Furnished	267XGFJP-*3 (22)	300 I	Eng	147				Furnished
267XMFJP-*5 (23)	265 I	Eng	184				Furnished	267XMFJP-*3 (23)	265 I	Eng	184				Furnished
267XSFJP-*5 (1)	250 I	Eng	229				Furnished	267XSFJP-*3 (1)	250 I	Eng	229				Furnished
287GBFJP-*5 (12)	300 C	Eng	85				Furnished	287GBFJP-*3 (12)	300 C	Eng	85				Furnished
287GBFJP-*8 (12)	300 C	Eng	81				Furnished	287GBFJP-*8 (12)	300 C	Eng	81				Furnished
287GCFJP-*5 (13)	390 C	Eng	103				Furnished	287GCFJP-*3 (13)	390 C	Eng	103				Furnished
287GCFJP-*8 (13)	390 C	Eng	97				Furnished	287GCFJP-*8 (13)	390 C	Eng	97				Furnished
287GDFJP-*5 (14)	390 C	Eng	123				Furnished	287GDFJP-*3 (14)	390 C	Eng	123				Furnished
287GDFJP-*8 (14)	390 C	Eng	116				Furnished	287GDFJP-*8 (14)	390 C	Eng	116				Furnished
287GGFJP-*5 (15)	360 C	Eng	147				Furnished	287GGFJP-*3 (15)	360 C	Eng	147				Furnished
287GGFJP-*8 (15)	360 C	Eng	137				Furnished	287GGFJP-*8 (15)	360 C	Eng	137				Furnished
287GKFJP-*5 (16)	340 C	Eng	164				Furnished	287GKFJP-*3 (16)	340 C	Eng	164				Furnished
287GMFJP-*5 (17)	318 C	Eng	184				Furnished	287GMFJP-*3 (17)	318 C	Eng	184				Furnished
287GMFJP-*8 (17)	318 C	Eng	170				Furnished	287GMFJP-*8 (17)	318 C	Eng	170				Furnished
287GPFJP-*5 (18)	290 C	Eng	205				Furnished	287GPFJP-*3 (18)	290 C	Eng	205				Furnished
287GPFJP-*8 (18)	290 C	Eng	189				Furnished	287GPFJP-*8 (18)	290 C	Eng	189				Furnished
287GSFJP-*5 (19)	265 C	Eng	229				Furnished	287GSFJP-*3 (19)	265 C	Eng	229				Furnished
287GSFJP-*8 (19)	265 C	Eng	210				Furnished	287GSFJP-*8 (19)	265 C	Eng	210				Furnished
877XAFJP-*5 (6)	591 C	Eng	116				Furnished	877XAFJP-*3 (6)	591 C	Eng	116				Furnished
877XBFJP-*5 (7)	552 C	Eng	124				Furnished	877XBFJP-*3 (7)	552 C	Eng	124				Furnished
877XCFJP-*5 (8)	515 C	Eng	133				Furnished	877XCFJP-*3 (8)	515 C	Eng	133				Furnished
877XDFJP-*5 (9)	482 C	Eng	142				Furnished	877XDFJP-*3 (9)	482 C	Eng	142				Furnished
877XEFJP-*5 (10)	425 C	Eng	161				Furnished	877XEFJP-*3 (10)	425 C	Eng	161				Furnished
877XFFJP-*5 (11)	376 C	Eng	182				Furnished	877XFFJP-*3 (11)	376 C	Eng	182				Furnished

Continued on Next Page

† I = Intermittent Torque Only - De-rate Torque Rating 30% for Continuous Duty. C = Continuous or Intermittent Torque - No need to De-Rate Torque Rating.

IMPORTANT: Refer to the back of this transmission section and read all notes associated with this application page. Some notes may affect the proper PTO selection.

CAUTION: Chelsea Recommends the Power Take-Off (PTO) installation on the 3000/4000 Series Transmissions to utilize a Vehicle Interface Module, or Chassis Manufacturer's equivalent controller to incorporate all the PTO control features available, this includes the "PTO Request" and "PTO Enable Output" feature. The "PTO Enable" circuit signals the Transmission Control Module (TCM) to maintain line pressure to the PTO. Failure to provide this signal may not be sufficient to the PTO. This may cause damage to the PTO and /or Transmission. Please see the Allison Transmission website and individual chassis manufacturer for installation details.

CAUTION: The torque values given for specific application pages may be limited to the rated torque of the Allison transmission.

- | | | | |
|--------------------------------------|--------------------------------------|--------------------------------------|--------------------------------------|
| (1) Input Gear Part No. 5-P-1173 | (7) Input Gear Part No. 5-P-1428-12X | (13) Input Gear Part No. 5-P-1491-2X | (19) Input Gear Part No. 5-P-1491-8X |
| (2) Input Gear Part No. 5-P-1225 | (8) Input Gear Part No. 5-P-1428-3X | (14) Input Gear Part No. 5-P-1491-3X | (20) Input Gear Part No. 5-P-912 |
| (3) Input Gear Part No. 5-P-1293 | (9) Input Gear Part No. 5-P-1428-4X | (15) Input Gear Part No. 5-P-1491-4X | (21) Input Gear Part No. 5-P-913 |
| (4) Input Gear Part No. 5-P-1350 | (10) Input Gear Part No. 5-P-1428-5X | (16) Input Gear Part No. 5-P-1491-5X | (22) Input Gear Part No. 5-P-914 |
| (5) Input Gear Part No. 5-P-1351 | (11) Input Gear Part No. 5-P-1428-6X | (17) Input Gear Part No. 5-P-1491-6X | (23) Input Gear Part No. 5-P-915 |
| (6) Input Gear Part No. 5-P-1428-11X | (12) Input Gear Part No. 5-P-1491-1X | (18) Input Gear Part No. 5-P-1491-7X | |

4700 4700 EVS 4700 OFS 4700 RDS 4700 SP 4800 4800 EVS 4800 SP	4850 EVS
--	----------

LEFT SIDE ONLY	TOP SIDE ONLY
TRANSMISSION GEAR DATA: L.S. 10-BOLT Opening Gear FORWARD of Centerline 97 Teeth - L.H. HELIX PITCH LINE TO APERTURE FACE: 1.7799" (45.2100MM)	TRANSMISSION GEAR DATA: TOP 10-BOLT Opening Gear FORWARD of Centerline 97 Teeth - L.H. HELIX PITCH LINE TO APERTURE FACE: 1.7799" (45.2100MM)

CAUTION: Application Approval Required for PTO Output Shaft Speeds Above 2500 RPM

PTO Model	Torq I / C †	Dir Rot	Engine %		Filler Block	Adapter Assy	Stud Kit	PTO Model	Torq I / C †	Dir Rot	Engine %		Filler Block	Adapter Assy	Stud Kit
			Fwd	Rev							Fwd	Rev			

ONE SPEED - TWO GEAR - POWERSHIFT (HYDRAULIC)

280GBFJP-*5 (12)	300 C	Eng	85				Furnished	280GBFJP-*5 (12)	300 C	Eng	85				Furnished
280GBFJP-*8 (12)	300 C	Eng	81				Furnished	280GBFJP-*8 (12)	300 C	Eng	81				Furnished
280GCFJP-*5 (13)	390 C	Eng	103				Furnished	280GCFJP-*5 (13)	390 C	Eng	103				Furnished
280GCFJP-*8 (13)	390 C	Eng	97				Furnished	280GCFJP-*8 (13)	390 C	Eng	97				Furnished
280GDFJP-*5 (14)	390 C	Eng	123				Furnished	280GDFJP-*5 (14)	390 C	Eng	123				Furnished
280GDFJP-*8 (14)	390 C	Eng	116				Furnished	280GDFJP-*8 (14)	390 C	Eng	116				Furnished
280GGFJP-*5 (15)	360 C	Eng	147				Furnished	280GGFJP-*5 (15)	360 C	Eng	147				Furnished
280GGFJP-*8 (15)	360 C	Eng	137				Furnished	280GGFJP-*8 (15)	360 C	Eng	137				Furnished
280GKFJP-*5 (16)	340 C	Eng	164				Furnished	280GKFJP-*5 (16)	340 C	Eng	164				Furnished
280GMFJP-*5 (17)	318 C	Eng	184				Furnished	280GMFJP-*5 (17)	318 C	Eng	184				Furnished
280GMFJP-*8 (17)	318 C	Eng	170				Furnished	280GMFJP-*8 (17)	318 C	Eng	170				Furnished
280GPFJP-*5 (18)	290 C	Eng	205				Furnished	280GPFJP-*5 (18)	290 C	Eng	205				Furnished
280GPFJP-*8 (18)	290 C	Eng	189				Furnished	280GPFJP-*8 (18)	290 C	Eng	189				Furnished
280GSFJP-*5 (19)	265 C	Eng	229				Furnished	280GSFJP-*5 (19)	265 C	Eng	229				Furnished
280GSFJP-*8 (19)	265 C	Eng	210				Furnished	280GSFJP-*8 (19)	265 C	Eng	210				Furnished
870XAFJP-*5 (6)	591 C	Eng	116				Furnished	870XAFJP-*3 (6)	591 C	Eng	116				Furnished
870XBFJP-*5 (7)	552 C	Eng	124				Furnished	870XBFJP-*3 (7)	552 C	Eng	124				Furnished
870XCFJP-*5 (8)	515C	Eng	133				Furnished	870XCFJP-*3 (8)	515C	Eng	133				Furnished
870XDFJP-*5 (9)	482 C	Eng	142				Furnished	870XDFJP-*3 (9)	482 C	Eng	142				Furnished
870XEFJP-*5 (10)	425 C	Eng	161				Furnished	870XEFJP-*3 (10)	425 C	Eng	161				Furnished
870XFFJP-*5 (11)	376 C	Eng	182				Furnished	870XFFJP-*3 (11)	376 C	Eng	182				Furnished

ONE SPEED - POWERSHIFT (HYDRAULIC) EXTENDED SHAFT

892HAFJW-*5 (6)	591 C	Eng	116				Furnished	892UAFJW-*5 (6)	591 C	Eng	116				Furnished
892HBFJW-*5 (7)	552 C	Eng	124				Furnished	892UBFJW-*5 (7)	552 C	Eng	124				Furnished
892HCFJW-*5 (8)	515C	Eng	133				Furnished	892UCFJW-*5 (8)	515C	Eng	133				Furnished
892HDFJW-*5 (9)	482 C	Eng	142				Furnished	892UDFJW-*5 (9)	482 C	Eng	142				Furnished
892HEFJW-*5 (10)	425 C	Eng	161				Furnished	892UEFJW-*5 (10)	425 C	Eng	161				Furnished
892HFFJW-*5 (11)	376 C	Eng	182				Furnished	892UFFJW-*5 (11)	376 C	Eng	182				Furnished

ONE SPEED - CONSTANT MESH EXTENDED SHAFT

899HAFJW-*5 (6)	591 C	Eng	116				Furnished	899UAFJW-*5 (6)	591 C	Eng	116				Furnished
-----------------	-------	-----	-----	--	--	--	-----------	-----------------	-------	-----	-----	--	--	--	-----------

Continued on Next Page

† I = Intermittent Torque Only - De-rate Torque Rating 30% for Continuous Duty. C = Continuous or Intermittent Torque - No need to De-Rate Torque Rating.

IMPORTANT: Refer to the back of this transmission section and read all notes associated with this application page. Some notes may affect the proper PTO selection.

CAUTION: Chelsea Recommends the Power Take-Off (PTO) installation on the 3000/4000 Series Transmissions to utilize a Vehicle Interface Module, or Chassis Manufacturer's equivalent controller to incorporate all the PTO control features available, this includes the "PTO Request" and "PTO Enable Output" feature. The "PTO Enable" circuit signals the Transmission Control Module (TCM) to maintain line pressure to the PTO. Failure to provide this signal may not be sufficient to the PTO. This may cause damage to the PTO and /or Transmission. Please see the Allison Transmission website and individual chassis manufacturer for installation details.

CAUTION: The torque values given for specific application pages may be limited to the rated torque of the Allison transmission.

- | | | |
|--------------------------------------|--------------------------------------|--------------------------------------|
| 6) Input Gear Part No. 5-P-1428-11X | (12) Input Gear Part No. 5-P-1491-1X | (18) Input Gear Part No. 5-P-1491-7X |
| (7) Input Gear Part No. 5-P-1428-12X | (13) Input Gear Part No. 5-P-1491-2X | (19) Input Gear Part No. 5-P-1491-8X |
| (8) Input Gear Part No. 5-P-1428-3X | (14) Input Gear Part No. 5-P-1491-3X | |
| (9) Input Gear Part No. 5-P-1428-4X | (15) Input Gear Part No. 5-P-1491-4X | |
| (10) Input Gear Part No. 5-P-1428-5X | (16) Input Gear Part No. 5-P-1491-5X | |
| (11) Input Gear Part No. 5-P-1428-6X | (17) Input Gear Part No. 5-P-1491-6X | |

ALL-19

ALLISON

CHELSEA®

4700 4700 EVS 4700 OFS 4700 RDS 4700 SP 4800 4800 EVS 4800 SP	4850 EVS
--	----------

LEFT SIDE ONLY	TOP SIDE ONLY
TRANSMISSION GEAR DATA: L.S. 10-BOLT Opening Gear FORWARD of Centerline 97 Teeth - L.H. HELIX PITCH LINE TO APERTURE FACE: 1.7799" (45.2100MM)	TRANSMISSION GEAR DATA: TOP 10-BOLT Opening Gear FORWARD of Centerline 97 Teeth - L.H. HELIX PITCH LINE TO APERTURE FACE: 1.7799" (45.2100MM)

CAUTION: Application Approval Required for PTO Output Shaft Speeds Above 2500 RPM

PTO Model	Torq	Dir Rot	Engine %		Filler Block	Adapter Assy	Stud Kit	PTO Model	Torq	Dir Rot	Engine %		Filler Block	Adapter Assy	Stud Kit
	I / C †		Fwd	Rev					I / C †		Fwd	Rev			

ONE SPEED - CONSTANT MESH EXTENDED SHAFT

899HBFJW-*5 (7)	552 C	Eng	124				Furnished	899UBFJW-*5 (7)	552 C	Eng	124				Furnished
899HCFJW-*5 (8)	515 C	Eng	133				Furnished	899UCFJW-*5 (8)	515 C	Eng	133				Furnished
899HDFJW-*5 (9)	482 C	Eng	142				Furnished	899UDFJW-*5 (9)	482 C	Eng	142				Furnished
899HEFJW-*5 (10)	425 C	Eng	161				Furnished	899UEFJW-*5 (10)	425 C	Eng	161				Furnished
899HFFJW-*5 (11)	376 C	Eng	182				Furnished	899UFFJW-*5 (11)	376 C	Eng	182				Furnished

† I = Intermittent Torque Only - De-rate Torque Rating 30% for Continuous Duty.

C = Continuous or Intermittent Torque - No need to De-Rate Torque Rating.

IMPORTANT: Refer to the back of this transmission section and read all notes associated with this application page. Some notes may affect the proper PTO selection.

CAUTION: Chelsea Recommends the Power Take-Off (PTO) installation on the 3000/4000 Series Transmissions to utilize a Vehicle Interface Module, or Chassis Manufacturer's equivalent controller to incorporate all the PTO control features available, this includes the "PTO Request" and "PTO Enable Output" feature. The "PTO Enable" circuit signals the Transmission Control Module (TCM) to maintain line pressure to the PTO. Failure to provide this signal may not be sufficient to the PTO. This may cause damage to the PTO and /or Transmission. Please see the Allison Transmission website and individual chassis manufacturer for installation details.

CAUTION: The torque values given for specific application pages may be limited to the rated torque of the Allison transmission.

(7) Input Gear Part No. 5-P-1428-12X
 (8) Input Gear Part No. 5-P-1428-3X
 (9) Input Gear Part No. 5-P-1428-4X
 (10) Input Gear Part No. 5-P-1428-5X
 (11) Input Gear Part No. 5-P-1428-6X

Allison

CHELSEA®

ALLISON

ALL-19C

4700 (4700 Family w/ Integral Cooler)
4800 (4800 Family w/ Integral Cooler)

LEFT SIDE ONLY

TOP SIDE ONLY

TRANSMISSION GEAR DATA:

L.S. 10-BOLT Opening Gear FORWARD of Centerline
97 Teeth - L.H. HELIX

PITCH LINE TO APERTURE FACE:

1.7799" (45.2100MM)

TRANSMISSION GEAR DATA:

TOP 10-BOLT Opening Gear FORWARD of Centerline
97 Teeth - L.H. HELIX

PITCH LINE TO APERTURE FACE:

1.7799" (45.2100MM)

CAUTION: Application Approval Required for PTO Output Shaft Speeds Above 2500 RPM

PTO Model	Torq I / C †	Dir Rot	Engine %		Filler Block	Adapter Assy	Stud Kit	PTO Model	Torq I / C †	Dir Rot	Engine %		Filler Block	Adapter Assy	Stud Kit
			Fwd	Rev							Fwd	Rev			

ONE SPEED - TWO GEAR - CONSTANT MESH

267SBFJP-*5 (4)	402 I	Eng	103				Furnished	267SBFJP-*3 (4)	402 I	Eng	103				Furnished
267SDFJP-*5 (3)	390 I	Eng	123				Furnished	267SDFJP-*3 (4)	390 I	Eng	123				Furnished
267SGFJP-*5 (2)	360 I	Eng	147				Furnished	267SGFJP-*3 (2)	360 I	Eng	147				Furnished
267SMFJP-*5 (5)	318 I	Eng	184				Furnished	267SMFJP-*3 (5)	318 I	Eng	184				Furnished
267SSFJP-*5 (1)	265 I	Eng	229				Furnished	267SSFJP-*3 (1)	265 I	Eng	229				Furnished
267XBFJP-*5 (20)	335 I	Eng	103				Furnished	267XBFJP-*3 (20)	335 I	Eng	103				Furnished
267XDFJP-*5 (21)	325 I	Eng	123				Furnished	267XDFJP-*3 (21)	325 I	Eng	123				Furnished
267XGFJP-*5 (22)	300 I	Eng	147				Furnished	267XGFJP-*3 (22)	300 I	Eng	147				Furnished
267XMFJP-*5 (23)	265 I	Eng	184				Furnished	267XMFJP-*3 (23)	265 I	Eng	184				Furnished
267XSFJP-*5 (1)	250 I	Eng	229				Furnished	267XSFJP-*3 (1)	250 I	Eng	229				Furnished
287GBFJP-*5 (12)	300 C	Eng	85				Furnished	287GBFJP-*3 (12)	300 C	Eng	85				Furnished
287GBFJP-*8 (12)	300 C	Eng	81				Furnished	287GBFJP-*8 (12)	300 C	Eng	81				Furnished
287GCFJP-*5 (13)	390 C	Eng	103				Furnished	287GCFJP-*3 (13)	390 C	Eng	103				Furnished
287GCFJP-*8 (13)	390 C	Eng	97				Furnished	287GCFJP-*8 (13)	390 C	Eng	97				Furnished
287GDFJP-*5 (14)	390 C	Eng	123				Furnished	287GDFJP-*3 (14)	390 C	Eng	123				Furnished
287GDFJP-*8 (14)	390 C	Eng	116				Furnished	287GDFJP-*8 (14)	390 C	Eng	116				Furnished
287GGFJP-*5 (15)	360 C	Eng	147				Furnished	287GGFJP-*3 (15)	360 C	Eng	147				Furnished
287GGFJP-*8 (15)	360 C	Eng	137				Furnished	287GGFJP-*8 (15)	360 C	Eng	137				Furnished
287GKFJP-*5 (16)	340 C	Eng	164				Furnished	287GKFJP-*3 (16)	340 C	Eng	164				Furnished
287GMFJP-*5 (17)	318 C	Eng	184				Furnished	287GMFJP-*3 (17)	318 C	Eng	184				Furnished
287GMFJP-*8 (17)	318 C	Eng	170				Furnished	287GMFJP-*8 (17)	318 C	Eng	170				Furnished
287GPFJP-*5 (18)	290 C	Eng	205				Furnished	287GPFJP-*3 (18)	290 C	Eng	205				Furnished
287GPFJP-*8 (18)	290 C	Eng	189				Furnished	287GPFJP-*8 (18)	290 C	Eng	189				Furnished
287GSFJP-*5 (19)	265 C	Eng	229				Furnished	287GSFJP-*3 (19)	265 C	Eng	229				Furnished
287GSFJP-*8 (19)	265 C	Eng	210				Furnished	287GSFJP-*8 (19)	265 C	Eng	210				Furnished
877XAFJP-*5 (6)	591 C	Eng	116				Furnished	877XAFJP-*3 (6)	591 C	Eng	116				Furnished
877XBFJP-*5 (7)	552 C	Eng	124				Furnished	877XBFJP-*3 (7)	552 C	Eng	124				Furnished
877XCFJP-*5 (8)	515 C	Eng	133				Furnished	877XCFJP-*3 (8)	515 C	Eng	133				Furnished
877XDFJP-*5 (9)	482 C	Eng	142				Furnished	877XDFJP-*3 (9)	482 C	Eng	142				Furnished
877XEFJP-*5 (10)	425 C	Eng	161				Furnished	877XEFJP-*3 (10)	425 C	Eng	161				Furnished
877XFFJP-*5 (11)	376 C	Eng	182				Furnished	877XFFJP-*3 (11)	376 C	Eng	182				Furnished

Continued on Next Page

† I = Intermittent Torque Only - De-rate Torque Rating 30% for Continuous Duty.

C = Continuous or Intermittent Torque - No need to De-Rate Torque Rating.

IMPORTANT: Refer to the back of this transmission section and read all notes associated with this application page. Some notes may affect the proper PTO selection.

CAUTION: Chelsea Recommends the Power Take-Off (PTO) installation on the 3000/4000 Series Transmissions to utilize a Vehicle Interface Module, or Chassis Manufacturer's equivalent controller to incorporate all the PTO control features available, this includes the "PTO Request" and "PTO Enable Output" feature. The "PTO Enable" circuit signals the Transmission Control Module (TCM) to maintain line pressure to the PTO. Failure to provide this signal may not be sufficient to the PTO. This may cause damage to the PTO and /or Transmission. Please see the Allison Transmission website and individual chassis manufacturer for installation details.

CAUTION: The torque values given for specific application pages may be limited to the rated torque of the Allison transmission.

(1) Input Gear Part No. 5-P-1173
(2) Input Gear Part No. 5-P-1225
(3) Input Gear Part No. 5-P-1293
(4) Input Gear Part No. 5-P-1350
(5) Input Gear Part No. 5-P-1351
(6) Input Gear Part No. 5-P-1428-11X

(7) Input Gear Part No. 5-P-1428-12X
(8) Input Gear Part No. 5-P-1428-3X
(9) Input Gear Part No. 5-P-1428-4X
(10) Input Gear Part No. 5-P-1428-5X
(11) Input Gear Part No. 5-P-1428-6X
(12) Input Gear Part No. 5-P-1491-1X

(13) Input Gear Part No. 5-P-1491-2X
(14) Input Gear Part No. 5-P-1491-3X
(15) Input Gear Part No. 5-P-1491-4X
(16) Input Gear Part No. 5-P-1491-5X
(17) Input Gear Part No. 5-P-1491-6X
(18) Input Gear Part No. 5-P-1491-7X

(19) Input Gear Part No. 5-P-1491-8X
(20) Input Gear Part No. 5-P-912
(21) Input Gear Part No. 5-P-913
(22) Input Gear Part No. 5-P-914
(23) Input Gear Part No. 5-P-915

ALL-19C

ALLISON

CHELSEA®

4700 (4700 Family w/ Integral Cooler)
4800 (4800 Family w/ Integral Cooler)

LEFT SIDE ONLY

TOP SIDE ONLY

TRANSMISSION GEAR DATA:

L.S. 10-BOLT Opening Gear FORWARD of Centerline
97 Teeth - L.H. HELIX

PITCH LINE TO APERTURE FACE:

1.7799" (45.2100MM)

TRANSMISSION GEAR DATA:

TOP 10-BOLT Opening Gear FORWARD of Centerline
97 Teeth - L.H. HELIX

PITCH LINE TO APERTURE FACE:

1.7799" (45.2100MM)

CAUTION: Application Approval Required for PTO Output Shaft Speeds Above 2500 RPM

PTO Model	Torq I / C †	Dir Rot	Engine %		Filler Block	Adapter Assy	Stud Kit	PTO Model	Torq I / C †	Dir Rot	Engine %		Filler Block	Adapter Assy	Stud Kit
			Fwd	Rev							Fwd	Rev			

ONE SPEED - TWO GEAR - POWERSHIFT (HYDRAULIC)

280GBFJP-*5 (12)	300 C	Eng	85				Furnished	280GBFJP-*5 (12)	300 C	Eng	85				Furnished
280GBFJP-*8 (12)	300 C	Eng	81				Furnished	280GBFJP-*8 (12)	300 C	Eng	81				Furnished
280GCFJP-*5 (13)	390 C	Eng	103				Furnished	280GCFJP-*5 (13)	390 C	Eng	103				Furnished
280GCFJP-*8 (13)	390 C	Eng	97				Furnished	280GCFJP-*8 (13)	390 C	Eng	97				Furnished
280GDFJP-*5 (14)	390 C	Eng	123				Furnished	280GDFJP-*5 (14)	390 C	Eng	123				Furnished
280GDFJP-*8 (14)	390 C	Eng	116				Furnished	280GDFJP-*8 (14)	390 C	Eng	116				Furnished
280GGFJP-*5 (15)	360 C	Eng	147				Furnished	280GGFJP-*5 (15)	360 C	Eng	147				Furnished
280GGFJP-*8 (15)	360 C	Eng	137				Furnished	280GGFJP-*8 (15)	360 C	Eng	137				Furnished
280GKFJP-*5 (16)	340 C	Eng	164				Furnished	280GKFJP-*5 (16)	340 C	Eng	164				Furnished
280GMFJP-*5 (17)	318 C	Eng	184				Furnished	280GMFJP-*5 (17)	318 C	Eng	184				Furnished
280GMFJP-*8 (17)	318 C	Eng	170				Furnished	280GMFJP-*8 (17)	318 C	Eng	170				Furnished
280GPFJP-*5 (18)	290 C	Eng	205				Furnished	280GPFJP-*5 (18)	290 C	Eng	205				Furnished
280GPFJP-*8 (18)	290 C	Eng	189				Furnished	280GPFJP-*8 (18)	290 C	Eng	189				Furnished
280GSFJP-*5 (19)	265 C	Eng	229				Furnished	280GSFJP-*5 (19)	265 C	Eng	229				Furnished
280GSFJP-*8 (19)	265 C	Eng	210				Furnished	280GSFJP-*8 (19)	265 C	Eng	210				Furnished
870XAFJP-*5 (6)	591 C	Eng	116				Furnished	870XAFJP-*3 (6)	591 C	Eng	116				Furnished
870XBFJP-*5 (7)	552 C	Eng	124				Furnished	870XBFJP-*3 (7)	552 C	Eng	124				Furnished
870XCFJP-*5 (8)	515C	Eng	133				Furnished	870XCFJP-*3 (8)	515C	Eng	133				Furnished
870XDFJP-*5 (9)	482 C	Eng	142				Furnished	870XDFJP-*3 (9)	482 C	Eng	142				Furnished
870XEFJP-*5 (10)	425 C	Eng	161				Furnished	870XEFJP-*3 (10)	425 C	Eng	161				Furnished
870XFFJP-*5 (11)	376 C	Eng	182				Furnished	870XFFJP-*3 (11)	376 C	Eng	182				Furnished

ONE SPEED - POWERSHIFT (HYDRAULIC) EXTENDED SHAFT

892CAFJW-*3 (6)	591 C	Eng	116				Furnished	892UAFJW-*5 (6)	591 C	Eng	116				Furnished
892CBFJW-*3 (7)	552 C	Eng	124				Furnished	892UBFJW-*5 (7)	552 C	Eng	124				Furnished
892CCFJW-*3 (8)	515C	Eng	133				Furnished	892UCFJW-*5 (8)	515C	Eng	133				Furnished
892CDFJW-*3 (9)	482 C	Eng	142				Furnished	892UDFJW-*5 (9)	482 C	Eng	142				Furnished
892CEFJW-*3 (10)	425 C	Eng	161				Furnished	892UEFJW-*5 (10)	425 C	Eng	161				Furnished
892CFFJW-*3 (11)	376 C	Eng	182				Furnished	892UFFJW-*5 (11)	376 C	Eng	182				Furnished

ONE SPEED - CONSTANT MESH EXTENDED SHAFT

899CAFJW-*3 (6)	591 C	Eng	116				Furnished	899UAFJW-*5 (6)	591 C	Eng	116				Furnished
-----------------	-------	-----	-----	--	--	--	-----------	-----------------	-------	-----	-----	--	--	--	-----------

Continued on Next Page

† I = Intermittent Torque Only - De-rate Torque Rating 30% for Continuous Duty.

C = Continuous or Intermittent Torque - No need to De-Rate Torque Rating.

IMPORTANT: Refer to the back of this transmission section and read all notes associated with this application page. Some notes may affect the proper PTO selection.

CAUTION: Chelsea Recommends the Power Take-Off (PTO) installation on the 3000/4000 Series Transmissions to utilize a Vehicle Interface Module, or Chassis Manufacturer's equivalent controller to incorporate all the PTO control features available, this includes the "PTO Request" and "PTO Enable Output" feature. The "PTO Enable" circuit signals the Transmission Control Module (TCM) to maintain line pressure to the PTO. Failure to provide this signal may not be sufficient to the PTO. This may cause damage to the PTO and /or Transmission. Please see the Allison Transmission website and individual chassis manufacturer for installation details.

CAUTION: The torque values given for specific application pages may be limited to the rated torque of the Allison transmission.

- (6) Input Gear Part No. 5-P-1428-11X
- (7) Input Gear Part No. 5-P-1428-12X
- (8) Input Gear Part No. 5-P-1428-3X
- (9) Input Gear Part No. 5-P-1428-4X
- (10) Input Gear Part No. 5-P-1428-5X
- (11) Input Gear Part No. 5-P-1428-6X
- (12) Input Gear Part No. 5-P-1491-1X
- (13) Input Gear Part No. 5-P-1491-2X
- (14) Input Gear Part No. 5-P-1491-3X
- (15) Input Gear Part No. 5-P-1491-4X
- (16) Input Gear Part No. 5-P-1491-5X
- (17) Input Gear Part No. 5-P-1491-6X
- (18) Input Gear Part No. 5-P-1491-7X
- (19) Input Gear Part No. 5-P-1491-8X

Allison

CHELSEA®

ALLISON

ALL-19C

4700 (4700 Family w/ Integral Cooler)
4800 (4800 Family w/ Integral Cooler)

LEFT SIDE ONLY

TOP SIDE ONLY

TRANSMISSION GEAR DATA:

L.S. 10-BOLT Opening Gear FORWARD of Centerline
97 Teeth - L.H. HELIX

PITCH LINE TO APERTURE FACE:

1.7799" (45.2100MM)

TRANSMISSION GEAR DATA:

TOP 10-BOLT Opening Gear FORWARD of Centerline
97 Teeth - L.H. HELIX

PITCH LINE TO APERTURE FACE:

1.7799" (45.2100MM)

CAUTION: Application Approval Required for PTO Output Shaft Speeds Above 2500 RPM

PTO Model	Torq	Dir Rot	Engine %		Filler Block	Adapter Assy	Stud Kit	PTO Model	Torq	Dir Rot	Engine %		Filler Block	Adapter Assy	Stud Kit
	I / C †		Fwd	Rev					I / C †		Fwd	Rev			

ONE SPEED - CONSTANT MESH EXTENDED SHAFT

899CBFJW-*3 (7)	552 C	Eng	124				Furnished	899UBFJW-*5 (7)	552 C	Eng	124				Furnished
899CCFJW-*3 (8)	515 C	Eng	133				Furnished	899UCFJW-*5 (8)	515 C	Eng	133				Furnished
899CDFJW-*3 (9)	482 C	Eng	142				Furnished	899UDFJW-*5 (9)	482 C	Eng	142				Furnished
899CEFJW-*3 (10)	425 C	Eng	161				Furnished	899UEFJW-*5 (10)	425 C	Eng	161				Furnished
899CFJW-*3 (11)	376 C	Eng	182				Furnished	899UFFJW-*5 (11)	376 C	Eng	182				Furnished

† I = Intermittent Torque Only - De-rate Torque Rating 30% for Continuous Duty.

C = Continuous or Intermittent Torque - No need to De-Rate Torque Rating.

IMPORTANT: Refer to the back of this transmission section and read all notes associated with this application page. Some notes may affect the proper PTO selection.

CAUTION: Chelsea Recommends the Power Take-Off (PTO) installation on the 3000/4000 Series Transmissions to utilize a Vehicle Interface Module, or Chassis Manufacturer's equivalent controller to incorporate all the PTO control features available, this includes the "PTO Request" and "PTO Enable Output" feature. The "PTO Enable" circuit signals the Transmission Control Module (TCM) to maintain line pressure to the PTO. Failure to provide this signal may not be sufficient to the PTO. This may cause damage to the PTO and /or Transmission. Please see the Allison Transmission website and individual chassis manufacturer for installation details.

CAUTION: The torque values given for specific application pages may be limited to the rated torque of the Allison transmission.

(7) Input Gear Part No. 5-P-1428-12X
 (8) Input Gear Part No. 5-P-1428-3X
 (9) Input Gear Part No. 5-P-1428-4X
 (10) Input Gear Part No. 5-P-1428-5X
 (11) Input Gear Part No. 5-P-1428-6X

ALL-19R

ALLISON

CHELSEA®

4700 (4700 Family w/ Retarder)
4800 (4800 Family w/ Retarder)

LEFT SIDE ONLY

TOP SIDE ONLY

TRANSMISSION GEAR DATA:

L.S. 10-BOLT Opening Gear FORWARD of Centerline
97 Teeth - L.H. HELIX

PITCH LINE TO APERTURE FACE:

1.7799" (45.2100MM)

TRANSMISSION GEAR DATA:

TOP 10-BOLT Opening Gear FORWARD of Centerline
97 Teeth - L.H. HELIX

PITCH LINE TO APERTURE FACE:

1.7799" (45.2100MM)

CAUTION: Application Approval Required for PTO Output Shaft Speeds Above 2500 RPM

PTO Model	Torq l / C †	Dir Rot	Engine %		Filler Block	Adapter Assy	Stud Kit	PTO Model	Torq l / C †	Dir Rot	Engine %		Filler Block	Adapter Assy	Stud Kit
			Fwd	Rev							Fwd	Rev			

ONE SPEED - TWO GEAR - CONSTANT MESH

267SBFJP-*5 (4)	402 l	Eng	103				Furnished	267SBFJP-*3 (4)	402 l	Eng	103				Furnished
267SDFJP-*5 (3)	390 l	Eng	123				Furnished	267SDFJP-*3 (4)	402 l	Eng	103				Furnished
267SGFJP-*5 (2)	360 l	Eng	147				Furnished	267SGFJP-*3 (2)	360 l	Eng	147				Furnished
267SMFJP-*5 (5)	318 l	Eng	184				Furnished	267SMFJP-*3 (5)	318 l	Eng	184				Furnished
267SSFJP-*5 (1)	265 l	Eng	229				Furnished	267SSFJP-*3 (1)	265 l	Eng	229				Furnished
267XBFJP-*5 (20)	335 l	Eng	103				Furnished	267XBFJP-*3 (20)	335 l	Eng	103				Furnished
267XDFJP-*5 (21)	325 l	Eng	123				Furnished	267XDFJP-*3 (21)	325 l	Eng	123				Furnished
267XGFJP-*5 (22)	300 l	Eng	147				Furnished	267XGFJP-*3 (22)	300 l	Eng	147				Furnished
267XMFJP-*5 (23)	265 l	Eng	184				Furnished	267XMFJP-*3 (23)	265 l	Eng	184				Furnished
267XSFJP-*5 (1)	250 l	Eng	229				Furnished	267XSFJP-*3 (1)	250 l	Eng	229				Furnished
287GBFJP-*5 (12)	300 C	Eng	85				Furnished	287GBFJP-*3 (12)	300 C	Eng	85				Furnished
287GBFJP-*8 (12)	300 C	Eng	81				Furnished	287GBFJP-*8 (12)	300 C	Eng	81				Furnished
287GCFJP-*5 (13)	390 C	Eng	103				Furnished	287GCFJP-*3 (13)	390 C	Eng	103				Furnished
287GCFJP-*8 (13)	390 C	Eng	97				Furnished	287GCFJP-*8 (13)	390 C	Eng	97				Furnished
287GDFJP-*5 (14)	390 C	Eng	123				Furnished	287GDFJP-*3 (14)	390 C	Eng	123				Furnished
287GDFJP-*8 (14)	390 C	Eng	116				Furnished	287GDFJP-*8 (14)	390 C	Eng	116				Furnished
287GGFJP-*5 (15)	360 C	Eng	147				Furnished	287GGFJP-*3 (15)	360 C	Eng	147				Furnished
287GGFJP-*8 (15)	360 C	Eng	137				Furnished	287GGFJP-*8 (15)	360 C	Eng	137				Furnished
287GKFJP-*5 (16)	340 C	Eng	164				Furnished	287GKFJP-*3 (16)	340 C	Eng	164				Furnished
287GMFJP-*5 (17)	318 C	Eng	184				Furnished	287GMFJP-*3 (17)	318 C	Eng	184				Furnished
287GMFJP-*8 (17)	318 C	Eng	170				Furnished	287GMFJP-*8 (17)	318 C	Eng	170				Furnished
287GPFJP-*5 (18)	290 C	Eng	205				Furnished	287GPFJP-*3 (18)	290 C	Eng	205				Furnished
287GPFJP-*8 (18)	290 C	Eng	189				Furnished	287GPFJP-*8 (18)	290 C	Eng	189				Furnished
287GSFJP-*5 (19)	265 C	Eng	229				Furnished	287GSFJP-*3 (19)	265 C	Eng	229				Furnished
287GSFJP-*8 (19)	265 C	Eng	210				Furnished	287GSFJP-*8 (19)	265 C	Eng	210				Furnished
877XAFJP-*5 (6)	591 C	Eng	116				Furnished	877XAFJP-*3 (6)	591 C	Eng	116				Furnished
877XBFJP-*5 (7)	552 C	Eng	124				Furnished	877XBFJP-*3 (7)	552 C	Eng	124				Furnished
877XCFJP-*5 (8)	515 C	Eng	133				Furnished	877XCFJP-*3 (8)	515 C	Eng	133				Furnished
877XDFJP-*5 (9)	482 C	Eng	142				Furnished	877XDFJP-*3 (9)	482 C	Eng	142				Furnished
877XEFJP-*5 (10)	425 C	Eng	161				Furnished	877XEFJP-*3 (10)	425 C	Eng	161				Furnished
877XFFJP-*5 (11)	376 C	Eng	182				Furnished	877XFFJP-*3 (11)	376 C	Eng	182				Furnished

Continued on Next Page

† I = Intermittent Torque Only - De-rate Torque Rating 30% for Continuous Duty.

C = Continuous or Intermittent Torque - No need to De-Rate Torque Rating.

IMPORTANT: Refer to the back of this transmission section and read all notes associated with this application page. Some notes may affect the proper PTO selection.

CAUTION: Chelsea Recommends the Power Take-Off (PTO) installation on the 3000/4000 Series Transmissions to utilize a Vehicle Interface Module, or Chassis Manufacturer's equivalent controller to incorporate all the PTO control features available, this includes the "PTO Request" and "PTO Enable Output" feature. The "PTO Enable" circuit signals the Transmission Control Module (TCM) to maintain line pressure to the PTO. Failure to provide this signal may not be sufficient to the PTO. This may cause damage to the PTO and /or Transmission. Please see the Allison Transmission website and individual chassis manufacturer for installation details.

CAUTION: The torque values given for specific application pages may be limited to the rated torque of the Allison transmission.

- | | | | |
|--------------------------------------|--------------------------------------|--------------------------------------|--------------------------------------|
| (1) Input Gear Part No. 5-P-1173 | (7) Input Gear Part No. 5-P-1428-12X | (13) Input Gear Part No. 5-P-1491-2X | (19) Input Gear Part No. 5-P-1491-8X |
| (2) Input Gear Part No. 5-P-1225 | (8) Input Gear Part No. 5-P-1428-3X | (14) Input Gear Part No. 5-P-1491-3X | (20) Input Gear Part No. 5-P-912 |
| (3) Input Gear Part No. 5-P-1293 | (9) Input Gear Part No. 5-P-1428-4X | (15) Input Gear Part No. 5-P-1491-4X | (21) Input Gear Part No. 5-P-913 |
| (4) Input Gear Part No. 5-P-1350 | (10) Input Gear Part No. 5-P-1428-5X | (16) Input Gear Part No. 5-P-1491-5X | (22) Input Gear Part No. 5-P-914 |
| (5) Input Gear Part No. 5-P-1351 | (11) Input Gear Part No. 5-P-1428-6X | (17) Input Gear Part No. 5-P-1491-6X | (23) Input Gear Part No. 5-P-915 |
| (6) Input Gear Part No. 5-P-1428-11X | (12) Input Gear Part No. 5-P-1491-1X | (18) Input Gear Part No. 5-P-1491-7X | |

Allison

CHELSEA®

ALLISON

ALL-19R

4700 (4700 Family w/ Retarder)
4800 (4800 Family w/ Retarder)

LEFT SIDE ONLY

TOP SIDE ONLY

TRANSMISSION GEAR DATA:

L.S. 10-BOLT Opening Gear FORWARD of Centerline
97 Teeth - L.H. HELIX

PITCH LINE TO APERTURE FACE:

1.7799" (45.2100MM)

TRANSMISSION GEAR DATA:

TOP 10-BOLT Opening Gear FORWARD of Centerline
97 Teeth - L.H. HELIX

PITCH LINE TO APERTURE FACE:

1.7799" (45.2100MM)

CAUTION: Application Approval Required for PTO Output Shaft Speeds Above 2500 RPM

PTO Model	Torq I / C †	Dir Rot	Engine %		Filler Block	Adapter Assy	Stud Kit	PTO Model	Torq I / C †	Dir Rot	Engine %		Filler Block	Adapter Assy	Stud Kit
			Fwd	Rev							Fwd	Rev			

ONE SPEED - TWO GEAR - POWERSHIFT (HYDRAULIC)

280GBFJP-*5 (12)	300 C	Eng	85				Furnished	280GBFJP-*5 (12)	300 C	Eng	85				Furnished
280GBFJP-*8 (12)	300 C	Eng	81				Furnished	280GBFJP-*8 (12)	300 C	Eng	81				Furnished
280GCFJP-*5 (13)	390 C	Eng	103				Furnished	280GCFJP-*5 (13)	390 C	Eng	103				Furnished
280GCFJP-*8 (13)	390 C	Eng	97				Furnished	280GCFJP-*8 (13)	390 C	Eng	97				Furnished
280GDFJP-*5 (14)	390 C	Eng	123				Furnished	280GDFJP-*5 (14)	390 C	Eng	123				Furnished
280GDFJP-*8 (14)	390 C	Eng	116				Furnished	280GDFJP-*8 (14)	390 C	Eng	116				Furnished
280GGFJP-*5 (15)	360 C	Eng	147				Furnished	280GGFJP-*5 (15)	360 C	Eng	147				Furnished
280GGFJP-*8 (15)	360 C	Eng	137				Furnished	280GGFJP-*8 (15)	360 C	Eng	137				Furnished
280GKFJP-*5 (16)	340 C	Eng	164				Furnished	280GKFJP-*5 (16)	340 C	Eng	164				Furnished
280GMFJP-*5 (17)	318 C	Eng	184				Furnished	280GMFJP-*5 (17)	318 C	Eng	184				Furnished
280GMFJP-*8 (17)	318 C	Eng	170				Furnished	280GMFJP-*8 (17)	318 C	Eng	170				Furnished
280GPFJP-*5 (18)	290 C	Eng	205				Furnished	280GPFJP-*5 (18)	290 C	Eng	205				Furnished
280GPFJP-*8 (18)	290 C	Eng	189				Furnished	280GPFJP-*8 (18)	290 C	Eng	189				Furnished
280GSFJP-*5 (19)	265 C	Eng	229				Furnished	280GSFJP-*5 (19)	265 C	Eng	229				Furnished
280GSFJP-*8 (19)	265 C	Eng	210				Furnished	280GSFJP-*8 (19)	265 C	Eng	210				Furnished
870XAFJP-*5 (6)	591 C	Eng	116				Furnished	870XAFJP-*3 (6)	591 C	Eng	116				Furnished
870XBFJP-*5 (7)	552 C	Eng	124				Furnished	870XBFJP-*3 (7)	552 C	Eng	124				Furnished
870XCFJP-*5 (8)	515 C	Eng	133				Furnished	870XCFJP-*3 (8)	515 C	Eng	133				Furnished
870XDFJP-*5 (9)	482 C	Eng	142				Furnished	870XDFJP-*3 (9)	482 C	Eng	142				Furnished
870XEFJP-*5 (10)	425 C	Eng	161				Furnished	870XEFJP-*3 (10)	425 C	Eng	161				Furnished
870XFFJP-*5 (11)	376 C	Eng	182				Furnished	870XFFJP-*3 (11)	376 C	Eng	182				Furnished

ONE SPEED - POWERSHIFT (HYDRAULIC) EXTENDED SHAFT

892JAFJW-*3 (6)	591 C	Eng	116				Furnished	892KAFJW-*5 (6)	591 C	Eng	116				Furnished
892JBFJW-*3 (7)	552 C	Eng	124				Furnished	892KBFJW-*5 (7)	552 C	Eng	124				Furnished
892JCFJW-*3 (8)	515 C	Eng	133				Furnished	892KCFJW-*5 (8)	515 C	Eng	133				Furnished
892JDFJW-*3 (9)	482 C	Eng	142				Furnished	892KDFJW-*5 (9)	482 C	Eng	142				Furnished
892JEFJW-*3 (10)	425 C	Eng	161				Furnished	892KEFJW-*5 (10)	425 C	Eng	161				Furnished
892JFFJW-*3 (11)	376 C	Eng	182				Furnished	892KFFJW-*5 (11)	376 C	Eng	182				Furnished

ONE SPEED - CONSTANT MESH EXTENDED SHAFT

899JAFJW-*3 (6)	591 C	Eng	116				Furnished	899KAFJW-*5 (6)	591 C	Eng	116				Furnished
-----------------	-------	-----	-----	--	--	--	-----------	-----------------	-------	-----	-----	--	--	--	-----------

Continued on Next Page

† I = Intermittent Torque Only - De-rate Torque Rating 30% for Continuous Duty.

C = Continuous or Intermittent Torque - No need to De-Rate Torque Rating.

IMPORTANT: Refer to the back of this transmission section and read all notes associated with this application page. Some notes may affect the proper PTO selection.

CAUTION: Chelsea Recommends the Power Take-Off (PTO) installation on the 3000/4000 Series Transmissions to utilize a Vehicle Interface Module, or Chassis Manufacturer's equivalent controller to incorporate all the PTO control features available, this includes the "PTO Request" and "PTO Enable Output" feature. The "PTO Enable" circuit signals the Transmission Control Module (TCM) to maintain line pressure to the PTO. Failure to provide this signal may not be sufficient to the PTO. This may cause damage to the PTO and /or Transmission. Please see the Allison Transmission website and individual chassis manufacturer for installation details.

CAUTION: The torque values given for specific application pages may be limited to the rated torque of the Allison transmission.

(6) Input Gear Part No. 5-P-1428-11X
(7) Input Gear Part No. 5-P-1428-12X
(8) Input Gear Part No. 5-P-1428-3X
(9) Input Gear Part No. 5-P-1428-4X
(10) Input Gear Part No. 5-P-1428-5X
(11) Input Gear Part No. 5-P-1428-6X

(12) Input Gear Part No. 5-P-1491-1X
(13) Input Gear Part No. 5-P-1491-2X
(14) Input Gear Part No. 5-P-1491-3X
(15) Input Gear Part No. 5-P-1491-4X
(16) Input Gear Part No. 5-P-1491-5X
(17) Input Gear Part No. 5-P-1491-6X

(18) Input Gear Part No. 5-P-1491-7X
(19) Input Gear Part No. 5-P-1491-8X

ALL-19R

ALLISON

CHELSEA®

4700 (4700 Family w/ Retarder)
4800 (4800 Family w/ Retarder)

LEFT SIDE ONLY

TOP SIDE ONLY

TRANSMISSION GEAR DATA:

L.S. 10-BOLT Opening Gear FORWARD of Centerline
97 Teeth - L.H. HELIX

PITCH LINE TO APERTURE FACE:

1.7799" (45.2100MM)

TRANSMISSION GEAR DATA:

TOP 10-BOLT Opening Gear FORWARD of Centerline
97 Teeth - L.H. HELIX

PITCH LINE TO APERTURE FACE:

1.7799" (45.2100MM)

CAUTION: Application Approval Required for PTO Output Shaft Speeds Above 2500 RPM

PTO Model	Torq	Dir Rot	Engine %		Filler Block	Adapter Assy	Stud Kit	PTO Model	Torq	Dir Rot	Engine %		Filler Block	Adapter Assy	Stud Kit
	I / C †		Fwd	Rev					I / C †		Fwd	Rev			

ONE SPEED - CONSTANT MESH EXTENDED SHAFT

899JBFJW-*3 (7)	552 C	Eng	124				Furnished	899KBFJW-*5 (7)	552 C	Eng	124				Furnished
899JCFJW-*3 (8)	515 C	Eng	133				Furnished	899KCFJW-*5 (8)	515 C	Eng	133				Furnished
899JDFJW-*3 (9)	482 C	Eng	142				Furnished	899KDFJW-*5 (9)	482 C	Eng	142				Furnished
899JEFJW-*3 (10)	425 C	Eng	161				Furnished	899KEFJW-*5 (10)	425 C	Eng	161				Furnished
899JFFJW-*3 (11)	376 C	Eng	182				Furnished	899KFFJW-*5 (11)	376 C	Eng	182				Furnished

Continued on Next Page

† I = Intermittent Torque Only - De-rate Torque Rating 30% for Continuous Duty.

C = Continuous or Intermittent Torque - No need to De-Rate Torque Rating.

IMPORTANT: Refer to the back of this transmission section and read all notes associated with this application page. Some notes may affect the proper PTO selection.

CAUTION: Chelsea Recommends the Power Take-Off (PTO) installation on the 3000/4000 Series Transmissions to utilize a Vehicle Interface Module, or Chassis Manufacturer's equivalent controller to incorporate all the PTO control features available, this includes the "PTO Request" and "PTO Enable Output" feature. The "PTO Enable" circuit signals the Transmission Control Module (TCM) to maintain line pressure to the PTO. Failure to provide this signal may not be sufficient to the PTO. This may cause damage to the PTO and /or Transmission. Please see the Allison Transmission website and individual chassis manufacturer for installation details.

CAUTION: The torque values given for specific application pages may be limited to the rated torque of the Allison transmission.

(7) Input Gear Part No. 5-P-1428-12X
 (8) Input Gear Part No. 5-P-1428-3X
 (9) Input Gear Part No. 5-P-1428-4X
 (10) Input Gear Part No. 5-P-1428-5X
 (11) Input Gear Part No. 5-P-1428-6X

CHELSEA®

ALLISON

ALL-20

TC-10

REAR SIDE ONLY

TRANSMISSION GEAR DATA:

REAR 04-BOLT Opening

PITCH LINE TO APERTURE FACE:

CAUTION: Application Approval Required for PTO Output Shaft Speeds Above 2500 RPM

PTO Model	Torq	Dir Rot	Engine %		Filler Block	Adapter Assy	Stud Kit	PTO Model	Torq	Dir Rot	Engine %		Filler Block	Adapter Assy	Stud Kit
	I / C †		Fwd	Rev					I / C †		Fwd	Rev			

REAR MOUNT - POWERSHIFT (HYDRAULIC)

590XRFJW-*X 650 Eng 128 Furnished

† I = Intermittent Torque Only - De-rate Torque Rating 30% for Continuous Duty.

C = Continuous or Intermittent Torque - No need to De-Rate Torque Rating.

IMPORTANT: Refer to the back of this transmission section and read all notes associated with this application page. Some notes may affect the proper PTO selection.

Allison

ALL-21

ALLISON

CHELSEA®

1700
1750
2700
2750

LEFT SIDE ONLY

RIGHT SIDE ONLY

TRANSMISSION GEAR DATA:

L.S. 06-BOLT Opening Gear FORWARD of Centerline
64 Teeth - SPUR

PITCH LINE TO APERTURE FACE:

1.0080" (25.6000MM)

TRANSMISSION GEAR DATA:

R.S. 06-BOLT Opening Gear FORWARD of Centerline
64 Teeth - SPUR

PITCH LINE TO APERTURE FACE:

1.0080" (25.6000MM)

CAUTION: Application Approval Required for PTO Output Shaft Speeds Above 2500 RPM

PTO Model	Torq I / C †	Dir Rot	Engine %		Filler Block	Adapter Assy	Stud Kit	PTO Model	Torq I / C †	Dir Rot	Engine %		Filler Block	Adapter Assy	Stud Kit
			Fwd	Rev							Fwd	Rev			
ONE SPEED - TWO GEAR - MECHANICAL SHIFT															
442GBHVP-*5 (3)	215 I	Eng	96				Furnished	442GBHVP-*3 (3)	215 I	Eng	96				Furnished
442GBHVX-*5 (3)	150 I	Eng	96				Furnished	442GBHVX-*3 (3)	150 I	Eng	96				Furnished
442GFHVP-*5 (2)	165 I	Eng	151				Furnished	442GFHVP-*3 (2)	165 I	Eng	151				Furnished
ONE SPEED - TWO GEAR POWERSHIFT (AIR OR HYDRAULIC)															
272GAHVP-*5 (5)	294 C	Eng	85				Furnished	272GAHVP-*3 (5)	294 C	Eng	85				Furnished
272GBHVP-*5 (6)	240 C	Eng	104				Furnished	272GBHVP-*3 (6)	240 C	Eng	104				Furnished
272GCHVP-*5 (7)	198 C	Eng	126				Furnished	272GCHVP-*3 (7)	198 C	Eng	126				Furnished
272GDHVP-*5 (8)	166 C	Eng	151				Furnished	272GDHVP-*3 (8)	166 C	Eng	151				Furnished
ONE SPEED - TWO GEAR - POWERSHIFT (HYDRAULIC)															
252GDHVP-*5 (1)	120 I	Eng	122				Furnished	252GDHVX-*5 (1)	120 I	Eng	122				Furnished
252GMHVP-*5 (4)	50 I	Eng	178				Furnished	252GMHVX-*5 (4)	50 I	Eng	178				Furnished
GEARED ADAPTERS															
626GHVX-4HV (2)	250 I	Opp			7-A-140(P)(9)		Furnished	626GHVX-3HV (2)	250 I	Opp			7-A-140(P)(9)		Furnished
630GHVX-4HV (2)	250 I	Opp			7-A-140(P)(9)		Furnished	630GHVX-3HV (2)	250 I	Opp			7-A-140(P)(9)		Furnished
645GHVX-4HV (2)	250 I	Opp			7-A-140(P)(9)		Furnished	645GHVX-3HV (2)	250 I	Opp			7-A-140(P)(9)		Furnished

See next page for more pump options.

Continued on Next Page

† I = Intermittent Torque Only - De-rate Torque Rating 30% for Continuous Duty.

C = Continuous or Intermittent Torque - No need to De-Rate Torque Rating.

IMPORTANT: Refer to the back of this transmission section and read all notes associated with this application page. Some notes may affect the proper PTO selection.**CAUTION:** Chelsea requires PTO installation on 1700/1750/2700/2750 series transmissions to utilize Vehicle Interface Module, or chassis manufacturer's equivalent controller to incorporate all the PTO control features available, including "PTO Request" and "PTO Enable Output" features. The "PTO Enable" circuit signals the Transmission Control Module (TCM) to maintain line pressure to the PTO. Failure to provide this signal will activate Variable Modulated Main Pressure which may not be sufficient for the PTO. This may cause damage to the PTO and/or transmission. Please see the Allison Transmission website and individual chassis manufacturer for installation details.**CAUTION:** Left side opening was unavailable on early 2019 models due to ABS module interference. Verify truck prior to ordering PTO.

- (1) Input Gear Part No. 5-P-1294
 (2) Input Gear Part No. 5-P-1300
 (3) Input Gear Part No. 5-P-1358
 (4) Input Gear Part No. 5-P-1386
 (5) Input Gear Part No. 5-P-1516-1X
 (6) Input Gear Part No. 5-P-1516-2X

- (7) Input Gear Part No. 5-P-1516-3X
 (8) Input Gear Part No. 5-P-1516-4X
 (9) Filler block furnished with PTO

CHELSEA®

ALLISON

ALL-21

1700
1750
2700
2750

LEFT SIDE ONLY

RIGHT SIDE ONLY

TRANSMISSION GEAR DATA:L.S. 06-BOLT Opening Gear FORWARD of Centerline
64 Teeth - SPUR**PITCH LINE TO APERTURE FACE:**

1.0080" (25.6000MM)

TRANSMISSION GEAR DATA:R.S. 06-BOLT Opening Gear FORWARD of Centerline
64 Teeth - SPUR**PITCH LINE TO APERTURE FACE:**

1.0080" (25.6032MM)

Pump Option Charts

252 Pumps offered in the PGP511 (5/8" - 9T / SAE A Flange – XE Output)

Option Order Code	Chelsea Pump Model	Displacement in ³ /rev	Displacement Gal/rev	Max Pressure PSI	Max Speed RPM	Shaft Size	Porting	
							Inlet	Outlet
1116	CGP-P11C016-1AC	0.37	0.003	3988	3500	5/8" - 9T	SAE12	SAE10
1121	CGP-P11C021-1AC	0.49	0.002	3988	4000	5/8" - 9T	SAE12	SAE10
1126	CGP-P11C026-1AC	0.61	0.003	3988	3600	5/8" - 9T	SAE12	SAE10
1129	CGP-P11C029-1AC	0.67	0.003	3988	3600	5/8" - 9T	SAE12	SAE10
1137	CGP-P11C037-1AC	0.85	0.004	3988	3300	5/8" - 9T	SAE12	SAE10
1449	CGP-P31C054-1AE	1.24	0.005	3500	3000	5/8" - 9T	SAE16	SAE10
1462	CGP-P31C061-1AE	1.40	0.006	3500	3000	5/8" - 9T	SAE16	SAE10

252 Pumps offered in the PGP511 (3/4" - 11T / SAE A Flange – AD Output)

Option Order Code	Chelsea Pump Model	Displacement in ³ /rev	Displacement Gal/rev	Max Pressure PSI	Max Speed RPM	Shaft Size	Porting	
							Inlet	Outlet
P37	CGP-P11C037-5AC	0.85	0.004	3988	3300	3/4" - 11T	SAE12	SAE10
P42	CGP-P11C042-5AC	0.98	0.004	3988	3000	3/4" - 11T	SAE12	SAE10
P55	CGP-P11C055-5AC	1.28	0.006	3408	2800	3/4" - 11T	SAE12	SAE10
P71	CGP-P11C071-5AC	1.65	0.007	2900	2400	3/4" - 11T	SAE12	SAE10
P82	CGP-P11C082-5AC	1.89	0.008	2465	2300	3/4" - 11T	SAE12	SAE10

Allison

Allison Notes

ALL-4

1. Speeds shown are with engine RPM at or above torque converter lockup speed. If the PTO is going to be operated below torque converter lockup speeds, contact your CHELSEA distributor for specific speeds and torque requirements.
2. 378840 street tee required for pressure lube and must be purchased separately. Only the pressure lube line 328075X (line to the idler pin) is included with the PTO For 270/271 Series due to varying valve installation locations on the vehicle installer must supply the following hoses or order the following separately. One 329087X (line from tranny to valve) and two 328075X (valve dump back to PTO housing & valve to PTO clutch).
3. 272 Series PTOs ordered with Pressure Lube and Hyd Shift will be supplied with (1) Lube Hose and (1) Shift Hose.
4. Do not use adapter gear assemblies on any Allison automatic transmissions.

ALL-5

1. If the 270/271/272/230/231 Series is ordered with the Drag Brake option, the rear cover of the PTO may interfere with the transmission clutch housing. Clearance must be verified prior to ordering PTO.
2. Speeds shown are with engine RPM at, or above, torque converter lockup speed. If the PTO is going to be operated below torque converter lockup speeds, contact your CHELSEA distributor for specific speeds and torque requirements.
3. 378970 street tee required for pressure lube for 1975 and after, and must be purchased separately. 378880 street tee required for pressure lube prior to 1975. Only the pressure lube line 328075X (line to the idler pin) is included with the PTO For 270/271 Series due to varying valve installation locations on the vehicle installer must supply the following hoses or order the following separately. One 329087X (line from tranny to valve) and two 328075X (valve dump back to PTO housing & valve to PTO clutch).
4. The AJ input gear designator shown on this application, which is a full addendum 6-pitch gear, is recommended for use on these transmissions. The AH input gear designator, which is a 6/8-pitch gear, can also be used on these transmissions; however, you may notice some additional rattle between the meshing gears.
5. 442 SERIES - The 442 listed above is a bulge up arrangement and pump clearance must be verified by the installer. The 442*3 arrangement has interference issues with the idler pin lube fitting against the bell housing.
6. Do not use adapter gear assemblies on any Allison automatic transmissions.

ALL-6

1. CRT-5630 & 5631 have only RH openings.
2. Right Side opening is optional. Input gear interference prohibits use of any PTOs other than those shown.
3. Do not use geared adapter assemblies on any Allison Automatic Transmission.
4. Do not use adapter gear assemblies on any Allison automatic transmissions.

ALL-8

1. CRT-5630 & 5631 have only RH openings.
2. Right Side opening is optional. Input gear interference prohibits use of any PTOs other than those shown.
3. Do not use geared adapter assemblies on any Allison Automatic Transmission.

ALL-11

1. RH opening is optional. Input gear interference prohibits use of any PTO other than those shown.
2. Use a 3/8" NPT to 1/4" NPT pipe reducer to adapt to the pressure lube hose supplied with the unit.
3. The CLT or CLBT prefix refers to an engine driven section mounted to the front of the transmission.
4. The 8000 and 9000 Series transmission models use all the same PTO models.
5. Only the pressure lube line 328075X (line to the idler pin) is included with the PTO.
6. The PTO input gear mates to a transmission PTO idler gear, the top opening will have 39 teeth and the side opening will have 52 teeth. These idler gears are driven from the 59 tooth PTO drive gear.
7. Do not use geared adapter assemblies on any Allison Automatic Transmission.

Allison Notes

ALL-12

1. For SAE 6-bolt aperture located 40° from vertical or approximately 10 o'clock when viewed from rear, see application number ALL-7 or contact your CHELSEA distributor for PTO applications prior to serial build number 32404. For applications after 32404 see application number ALL-6.
2. Engine must be stopped in order to engage/disengage Mechanical shift PTOs.
3. Left side opening located at approximately 7 o'clock, right side at 1 o'clock as viewed from rear of transmission.
4. Lube Tee Required - 378897 Street Tee is required for pressure lube PTOs and must be purchased separately. Only the pressure lube hose assembly 328075X (line to the idler pin) is included with the PTO. For 270/271 Series, due to varying valve installation locations on the vehicle, installer must supply the following hoses or order the following separately. One 329087X (line from tranny to valve) and two 328075X (valve dump back to PTO housing & valve to PTO clutch).
5. Do not use geared adapter assemblies on any Allison Automatic Transmission.

ALL-13

1. 890/897 Series - The Combined Weight of Pump, Fittings and Hoses Should Not Exceed 120 Lbs. Refer to Owner's Manual (HY25-1890- M1/US) for Complete Details.
2. When direct mounting a Parker P2 060 piston pump to a 267 Series PTO on the left (drivers) side opening, the PTO must be ordered as a 3 assembly arrangement for pump clearance.
3. All models require a hose assembly. For the 267 Series, use 329130-1X for left side, 329130-6X for top right and 329130-4X for right side. THESE HOSE ASSEMBLIES MUST BE ORDERED SEPARATELY. For 280/287, 870/877 and 890/897 Series - All Mounting Hardware and Hose Assemblies are Included with the Unit.
4. The 267 Series is not available in the 3 arrangement with an XK output due to interference with the pressure lube fitting.
5. Wiring harness 379926 must be used in 2003 GM trucks for the 277, 278 and 859 Series PTOs if the GM provided in-dash PTO switch is used to control PTO operations.
6. Do not use adapter gear assemblies on Allison 3000/4000 Series Automatic Transmissions.
7. Quiet Gear™ input option QT is available on 870/877 and 870L/877L Series PTOs.
8. For an 870-XL and 877-XL (870L and 877L) Extended Shaft PTOs, the transmission bracket (50-P-XXX) and bolt kit (329928-1X) must be ordered separately: Left Side 5 Arrangement use 50-P-162, Left Side 3 Arrangement use 50-P-164, Right Side 5 Arrangement use 50-P-161, Right Side 3 Arrangement use 50-P-157.

ALL-13C

1. When direct mounting a Parker P2 060 piston pump to a 267 Series PTO on the left (drivers) side opening, the PTO must be ordered as a 3 assembly arrangement for pump clearance.
2. All models require a hose assembly. For the 267 Series, use 329130-1X for left side, 329130-6X for top right and 329130-4X for right side. For the 269, 277, 278 and 867 Series, use 329130-5X for left side, 329075-2X for top right and 329075-1X for right side. If ordering shift options R, G or H for 277, 278 or 859 Series use 329130-5X for left side, 329075-1X for right side THESE HOSE ASSEMBLIES MUST BE ORDERED SEPARATELY. For 859, 870/877 and 890/897 Series - All Mounting Hardware and Hose Assemblies are Included with the Unit.
3. The 267 Series is not available in the 3 arrangement with an XK output due to interference with the pressure lube fitting.
4. 890/897 Series - The Combined Weight of Pump, Fittings and Hoses Should Not Exceed 120 lbs. Refer to Owner's Manual (HY25-1890- M1/US) for Complete Details
5. Quiet Gear™ input option (QT) is available on 870/877 and 870L/877L Series PTOs.
6. For an 870-XL and 877-XL (870L and 877L) Extended Shaft PTOs, the transmission bracket (50-P-XXX) and bolt kit (329928-1X) must be ordered separately: Left Side 5 Arrangement use 50-P-162, Left Side 3 Arrangement use 50-P-164, Right Side 5 Arrangement use 50-P-161, Right Side 3 Arrangement use 50-P-157.

Allison Notes

ALL-13R

1. When direct mounting a Parker P2 060 piston pump to a 267 Series PTO on the left (drivers) side opening, the PTO must be ordered as a 3 assembly arrangement for pump clearance.
2. All models require a hose assembly. For the 267 Series, use 329130-1X for left side, 329130-6X for top right and 329130-4X for right side. THESE HOSE ASSEMBLIES MUST BE ORDERED SEPARATELY. For 280, 870/877 and 890/897 Series - All Mounting Hardware and Hose Assemblies are Included with the Unit.
3. The 267 Series is not available in the 3 arrangement with an XK output due to interference with the pressure lube fitting.
4. 890/897 Series - The Combined Weight of Pump, Fittings and Hoses Should Not Exceed 120 lbs. Refer to Owner's Manual (HY25-1890- M1/US) for Complete Details
5. Do not use adapter gear assemblies on Allison 3000/4000 Series Automatic Transmissions.
6. Quiet Gear™ input option QT is available on 870/877 and 870L/877L Series PTOs.
7. For an 870-XL and 877-XL (870L and 877L) Extended Shaft PTOs, the transmission bracket (50-P-XXX) and bolt kit (329928-3X) must be ordered separately: Left Side 5 Arrangement use 50-P-162, Left Side 3 Arrangement use 50-P-164, Right Side 5 Arrangement use 50-P-161, Right Side 3 Arrangement use 50-P-157.

ALL-13EC

1. All models require a hose assembly. For 870L/877L - All Mounting Hardware and Hose Assemblies are Included with the Unit.
2. Quiet Gear™ input option (QT) is available on 870L/877L Series PTOs.
3. For 870L/877L, utilize Daimler's integral PTO support bracket.

ALL-14

1. LEFT SIDE - 870/877/890/897 PTOs may encounter interference with leaf spring assembly when using the 3 or 5 arrangement on the Peterbilt 320 chassis.
2. The Right Side opening is located at approximately 1 o'clock when viewed from the rear. All PTOs mounted in this location require pressure lubrication.
3. All models require a hose assembly. For the 267 Series, use 329130-1X for left side, 329130-6X for top right and 329130-4X for right side. THESE HOSE ASSEMBLIES MUST BE ORDERED SEPARATELY. For 280, 870/877 and 890/897 Series - All Mounting Hardware and Hose Assemblies are Included with the Unit.
4. The 267 Series is not available in the 3 arrangement with an XK output due to interference with the pressure lube fitting.
5. 890/897 Series - The Combined Weight of Pump, Fittings and Hoses Should Not Exceed 120 lbs. Refer to Owner's Manual (HY25-1890- M1/US) for Complete Details.
6. Do not use Adapter Gear Assemblies on Allison 3000/4000 Series Automatic Transmissions.
7. Quiet Gear™ input option QT is available on 870/877 and 870L/877L Series PTOs.
8. For an 870-XL and 877-XL (870L and 877L) Extended Shaft PTOs, the transmission bracket (50-P-XXX) and bolt kit (329928-1X) must be ordered separately: Left Side 5 Arrangement use 50-P-165, Left Side 3 Arrangement use 50-P-158.

ALL-14C

1. All models require a hose assembly. For the 267 Series, use 329130-1X for left side, 329130-6X for top right and 329130-4X for right side. THESE HOSE ASSEMBLIES MUST BE ORDERED SEPARATELY. For 280, 870/877 and 890/897 Series - All Mounting Hardware and Hose Assemblies are Included with the Unit.
2. 890/897 Series - The Combined Weight of Pump, Fittings and Hoses Should Not Exceed 120 lbs. Refer to Owner's Manual (HY25-1890- M1/US) for Complete Details.
3. The Right Side opening is located at approximately 1 o'clock when viewed from the rear. All PTOs mounted in this location require pressure lubrication.
4. Quiet Gear™ input option QT is available on 870/877 and 870L/877L Series PTOs.
5. For an 870-XL and 877-XL (870L and 877L) Extended Shaft PTOs, the transmission bracket (50-P-XXX) and bolt kit (329928-1X) must be ordered separately: Left Side 3 Arrangement use 50-P-158.

Allison Notes

ALL-14R

1. The Right Side opening is located at approximately 1 o'clock when viewed from the rear. All PTOs mounted in this location require pressure lubrication.
2. All models require a hose assembly. For the 267 Series, use 329130-1X for left side, 329130-6X for top right and 329130-4X for right side. THESE HOSE ASSEMBLIES MUST BE ORDERED SEPARATELY. For 280, 870/877 and 890/897 Series - All Mounting Hardware and Hose Assemblies are Included with the Unit.
3. 890/897 Series - The Combined Weight of Pump, Fittings and Hoses Should Not Exceed 120 Lbs. Refer to Owner's Manual (HY25-1890- M1/US) for Complete Details.
4. The 267 Series is not available in the 3 arrangement with an XK output due to interference with the pressure lube fitting.
5. Do not use Adapter Gear Assemblies on Allison 3000/4000 Series Automatic Transmissions.
6. Quiet Gear™ input option QT is available on 870/877 and 870L/877L Series PTOs.
7. For an 870-XL and 877-XL (870L and 877L) Extended Shaft PTOs, the transmission bracket (50-P-XXX) and bolt kit (329928-2X) must be ordered separately: Left Side 5 Arrangement use 50-P-165, Left Side 3 Arrangement use 50-P-158.

ALL-15

1. There is a torque converter lock up feature available with the 1000/2000/2400 series transmissions. The torque converter lock up feature comes on and is controlled by the Transmission Control Module (TCM) when a signal is provided to the "PTO Enable" circuit of the TCM by the PTO switch. Lock up will only come on in the "NEUTRAL" and "PARK" positions at 1100 RPM transmission turbine speed. This equates to 1200-1250 RPM or higher engine speed, depending on PTO load. The lock up clutch does not come on automatically in "DRIVE." Refer to the appropriate owner's manual for wiring installation.
2. If the 442 Series is ordered with Pressure Lube, Hose 328075X is supplied with the PTO A Restrictor Orifice, 379896 (442*FHVP) or 379594 (442*BHVP) is required and is shipped with the PTO.
3. 442*B Ratio - DO NOT USE with Geared Adapter.
4. Geared Adapters - 626/630/645 listed on this application page are for the 442 (F Ratio Only) or 272. 442*F Ratio - Use 442ZFHV with (1) 7-A-140 filler block and (1) 328170-94X stud kit when mounting the PTO to one of the adapters listed. 272 - Use 272L*HV (deep mount) with (1) 7-A-140 and (1) 328170-94X. Use 35-P-41 gasket between transmission and adapter. Use filler block (1) 7-A-140 between the adapter and PTO with 35-P-1 or 2 shim gaskets to obtain .006-012" of backlash between the driver gears.
5. To maintain proper hydraulic pressure to PTO clutch, connect Chelsea specified wire to Allison "PTO Request" circuit wire/pin within transmission TCM. Location of PTO Request wire/pin is dependant on Transmission Location Code. For assistance, contact your local Allison representative or contact Allison Technical Assistance at 1-800-252-5283.
6. Limited Ratios - the K Ratio and above will not fit on this transmission due to adjacent interference with the input ratio gear. In some instances the D ratio will not fit either. There seems to be two variations of the transmission case that effect the D ratio, but we have no way to confirm which case is which.
7. A lube T fitting is required in the oil return cooling line to supply low pressure oil to the idler shaft of the 252 (left side), 272, or 442 Series PTO. The 378840 T fitting is for transmission model 1000 with the SAE #3 bell housing, 378970 T fitting is for the transmission model 1000/2000/2400 with the SAE #2 bell housing, or the low pressure return line may be cut with a tube cutter and a compression T fitting may be installed.
8. MY2003 and after GM C/K Series 4500/5500/6500/7500/8500 Trucks - If using the GM provided in-dash switch, use wiring harness 379924 for the 230/231/270/271/272 Series PTOs. The kits must be ORDERED SEPARATELY.
9. 252 Series PTO - (GM C/K Series 2003-Current) If using the factory provided GM PTO switch, an additional wiring harness is required. MY2003-2006 - Order 329619X; MY2007-2014 - Order 329620X; MY2015-Current - Order 75-P-33. Wiring harnesses must be ordered separately.
10. 272 Low Profile - MY2022+ MACK MD6 chassis has cross-member interference on the driver side and a 272N cannot be used. 272G in a 5 arrangement is recommended if there are no other obstructions.

ALL-16

1. The Allison Model MD-3066 has two 10-Bolt aperture openings located at 9 o'clock on the left side and 2 o'clock on the right side (Top Right).
2. All models require a hose assembly. For the 267 Series, use 329130-1X for left side, 329130-6X for top right and 329130-4X for right side. THESE HOSE ASSEMBLIES MUST BE ORDERED SEPARATELY. For 280, 870/877 and 890/897 Series - All Mounting Hardware and Hose Assemblies are Included with the Unit.
3. The 267 Series is not available in the 3 arrangement with an XK output due to interference with the pressure lube fitting.
4. 890/897 Series - The combined weight of pump, fittings, and hoses should not exceed 120 lbs. without required support brackets. Refer to Owner's Manual (HY25-1890-M1/US) for complete details.
5. Do not use Geared Adapters Assemblies on Allison 3000/4000 Series Automatic Transmissions.
6. Quiet Gear™ input option (QT) is available on 870/877 and 870L/877L Series PTOs.
7. For an 870-XL and 877-XL (870L and 877L) Extended Shaft PTOs, the transmission bracket (50-P-XXX) and bolt kit (329928-1X) must be ordered separately: Left Side 5 Arrangement use 50-P-163.

Allison Notes**ALL-16C**

1. The 280, 870, and 890 will not fit in a 3 arrangement on the left side of this transmission with a cooler. The remote and integral valve cap assembly hits the transmission.
2. The Allison Model MD-3066 has two 10 bolt aperture openings located at 9 o'clock on the left side and 2 o'clock on the right side (Top Right). Every PTO mounted on this transmission must have the pressure lube option (P).
3. All models require a hose assembly. For the 267 Series, use 329130-1X for left side, 329130-6X for top right and 329130-4X for right side. THESE HOSE ASSEMBLIES MUST BE ORDERED SEPARATELY. For 280, 870/877 and 890/897 Series - All Mounting Hardware and Hose Assemblies are Included with the Unit.
4. The 267 Series is not available in the 3 arrangement with an XK output due to interference with the pressure lube fitting.
5. 890/897 Series - The combined weight of pump, fittings, and hoses should not exceed 120 lbs. without required support brackets. Refer to Owner's Manual (HY25-1890-M1/US) for complete details.
6. Do not use Geared Adapter Assemblies on Allison 3000/4000 Series Automatic Transmissions.
7. Quiet Gear™ input option (QT) is available on 870/877 and 870L/877L Series PTOs.
8. For an 870-XL and 877-XL (870L and 877L) Extended Shaft PTOs, the transmission bracket (50-P-XXX) and bolt kit (329928-1X) must be ordered separately: Left Side (5 Arrangement) use 50-P-163.

ALL-16EV

1. "How to Calculate" Torque for two (2) PTO INTERMITTENT Applications. Combined Total = [Actual Torque of PTO#1] divided by [Per Cent of Engine] + [Actual Torque of PTO#2] divided by [Per Cent of Engine]. Application is OK if Combined Torque is less than 790 lbs-ft for Intermittent use and the PTOs Torque Requirements are less than Stated PTO Torque Limits. For CONTINUOUS Applications = Application is OK if Combined Torque is less than 685 lbs-ft and the PTOs Torque Requirements are less than Stated PTO Torque Limits x .80.
2. All Stated Torque Values on this page are for CONTINUOUS Duty Cycles for Fire & Emergency Applications with ONE (1) PTO Torque Values are as follows - Continuous/Intermittent (lb-ft): "A" Ratio-670/793, "B" Ratio-632/742, "C" Ratio-588/696, "D" Ratio-554/652, "E" Ratio-486/574, "F" Ratio-429/507, "G" Ratio 379/447 and "J" Ratio-334/394. Refer to Allison Tech Data (Watch # 291) for more information on Fire & Emergency PTO Applications and Transmission Torque Ratings.
3. The Stated INTERMITTENT Torque Values on this Page are for Fire and Emergency Vehicle Applications with One PTO not to Exceed 790 Lbs.ft [1068 Nm] on the Transmission PTO Drive Gear. For Two PTO Applications the Combined Torque Valve Can Not Exceed 790 lbs-ft [1068 Nm] at the Transmission PTO Drive Gear. See Example on "How to Calculate".
4. All models require a hose assembly. For the 267 Series, use 329130-1X for left side, 329130-6X for top right and 329130-4X for right side. THESE HOSE ASSEMBLIES MUST BE ORDERED SEPARATELY. For 280/287, 870/877 and 890/897 Series - All Mounting Hardware and Hose Assemblies are Included with the Unit.
5. The 267 Series is not available in the 3 arrangement with an XK output due to interference with the pressure lube fitting.
6. 890/897 Series - The combined weight of pump, fittings, and hoses should not exceed 120 lbs. without required support brackets. Refer to Owner's Manual (HY25-1890-M1/US) for complete details.
7. Allison Transmission Maximum Power Capability of the Top Mount PTO Drive Gear on MD Series Transmissions used in the Fire and Emergency Vehicle Vocations has been Increased. The ratings on this page are valid only for the Side/Top Mount PTO Options. Refer to Allison Watch #291 for complete details.
8. Quiet Gear™ input option (QT) is available on 870/877 and 870L/877L Series PTOs.
9. For an 870-XL and 877-XL (870L and 877L) Extended Shaft PTOs, the transmission bracket (50-P-XXX) and bolt kit (329928-1X) must be ordered separately: Left Side (5 Arrangement) use 50-P-163.

ALL-16R

1. The Allison Model MD-3066 has two 10 bolt aperture openings located at 9 o'clock on the left side and 2 o'clock on the right side (Top Right). Every PTO mounted on this transmission must have the pressure lube option (P).
2. All models require a hose assembly. For the 267 Series, use 329130-1X for left side, 329130-6X for top right and 329130-4X for right side. THESE HOSE ASSEMBLIES MUST BE ORDERED SEPARATELY. For 280, 870/877 and 890/897 Series - All Mounting Hardware and Hose Assemblies are Included with the Unit.
3. The 267 Series is not available in the 3 arrangement with an XK output due to interference with the pressure lube fitting.
4. 890/897 Series - The combined weight of pump, fittings, and hoses should not exceed 120 lbs. without required support brackets. Refer to Owner's Manual (HY25-1890-M1/US) for complete details.
5. Do not use Adapter Gear Assemblies on Allison 3000/4000 Series Automatic Transmissions.
6. Quiet Gear™ input option (QT) is available on 870/877 and 870L/877L Series PTOs.
7. For an 870-XL and 877-XL (870L and 877L) Extended Shaft PTOs, the transmission bracket (50-P-XXX) and bolt kit (329928-3X) must be ordered separately: Left Side (5 ARR) use 50-P-163.

Allison Notes

ALL-17

1. For MY2015 GM has changed the engine exhaust design. The exhaust pipe can not be removed as in previous model years. This is causing issues with PTO installation. Contact GM Upfitter Integration for assistance on PTO installation.
2. There is torque converter lock up feature available with the 1000 series transmission. The torque converter lock up feature comes on and is controlled by the Transmission Control Module (TCM) at 1100 RPM transmission turbine speed when a signal is provided to the "PTO Enable" circuit of the TCM by the PTO switch. This equates to 1200-1250 RPM or higher engine speed, depending on PTO load. Lock up will only come on in the "PARK" position. The lock up clutch does not come on automatically in "DRIVE" at 1100 RPM. Refer to the appropriate owner's manual for wiring installation.
3. The PTO torque ratings shown are based on the maximum allowable torque of 250 lb-ft at the 64 tooth gear in the transmission with the PTO on one opening only. With PTOs mounted on both openings the maximum allowable torque at the 64 tooth gear in the transmission is 200 lb-ft. For a more precise evaluation of your PTO application refer to the Allison Body Builders Book, Section F, PTO Systems Provisions.
4. The 252 Series for MY2015 and later GM C/K series Cab/Chassis order wiring harness part number 75-P-33. For 2007-2014 order Chelsea part number 329620X. This harness must be ordered separately and is required for proper PTO to Engine interface operation. Refer to GM UI Bulletin #80.
5. Only the 12V B option shifter can be used on this application.
6. The left PTO aperture opening on this application is not usable due to engine fuel lines blocking the opening.

ALL-18

1. All models require a hose assembly. For the 267 Series, use 329130-1X for left side, 329130-6X for top right and 329130-4X for right side. THESE HOSE ASSEMBLIES MUST BE ORDERED SEPARATELY. For 280, 870/877 and 890/897 Series - All Mounting Hardware and Hose Assemblies are Included with the Unit.
2. The 267 Series is not available in the 3 arrangement with an XK output due to interference with the pressure lube fitting.
3. The 3700 and MD3070 have PTO Availability on the Left-Side Only. The Right-Side is Utilized by OE Equipment. The Transfer Case is Integral to the Transmission
4. Do not use Geared Adapter Assemblies on Allison 3000/4000 Series Automatic Transmissions.

ALL-19

1. The Right Side opening is located at approximately 1 o'clock when viewed from the rear. All PTOs mounted in this location require pressure lubrication.
2. All models require a hose assembly. For the 267 Series, use 329130-1X for left side, 329130-6X for top right and 329130-4X for right side. THESE HOSE ASSEMBLIES MUST BE ORDERED SEPARATELY. For 280, 870/877 and 890/897 Series - All Mounting Hardware and Hose Assemblies are Included with the Unit.
3. The 267 Series is not available in the 3 arrangement with an XK output due to interference with the pressure lube fitting.
4. 892/899 Series - The combined weight of pump, fittings, and hoses should not exceed 120 lbs. without required support brackets. Refer to Owner's Manual (HY25-1890-M1/US) for complete details.
5. Do not use Geared Adapter Assemblies on Allison 3000/4000 Series Automatic Transmissions.

ALL-19C

1. The Right Side opening is located at approximately 1 o'clock when viewed from the rear. All PTOs mounted in this location require pressure lubrication.
2. All models require a hose assembly. For the 267 Series, use 329130-1X for left side, 329130-6X for top right and 329130-4X for right side. THESE HOSE ASSEMBLIES MUST BE ORDERED SEPARATELY. For 280, 870/877 and 890/897 Series - All Mounting Hardware and Hose Assemblies are Included with the Unit.
3. The 267 Series is not available in the 3 arrangement with an XK output due to interference with the pressure lube fitting.
4. 892/899 Series - The combined weight of pump, fittings, and hoses should not exceed 120 lbs. without required support brackets. Refer to Owner's Manual (HY25-1890-M1/US) for complete details.
5. Do not use Geared Adapter Assemblies on Allison 3000/4000 Series Automatic Transmissions.

Allison Notes

ALL-19R

1. The Right Side opening is located at approximately 1 o'clock when viewed from the rear. All PTOs mounted in this location require pressure lubrication.
2. All models require a hose assembly. For the 267 Series, use 329130-1X for left side, 329130-6X for top right and 329130-4X for right side. THESE HOSE ASSEMBLIES MUST BE ORDERED SEPARATELY. For 280, 870/877 and 890/897 Series - All Mounting Hardware and Hose Assemblies are Included with the Unit.
3. The 267 Series is not available in the 3 arrangement with an XK output due to interference with the pressure lube fitting.
4. 892/899 SERIES - The combined weight of pump, fittings, and hoses should not exceed 120 lbs. without required support brackets. Refer to Owner's Manual (HY25-1890-M1/US) for complete details.
5. Do not use Geared Adapter Assemblies on Allison 3000/4000 Series Automatic Transmissions.

ALL-20

1. The PTO Provision is optional for the TC10. All TC10 Transmissions have a PTO pad and cover located on the rear cover. The TC10 includes the PTO drive shaft if the PTO option is ordered with the transmission. If the transmission does not have optional PTO provision, the PTO adapter can be added (Contact Allison)
2. For all PTO installations, the Allison 5th Generation Controls' PTO Drive Interface must be integrated into the installation of the PTO control.

ALL-21

1. The PTO torque ratings shown are based on the maximum allowable torque of 250 lb/ft at the 64 tooth gear in the transmission with the PTO on one opening only. With PTOs mounted on both openings, the maximum allowable torque at the 64 tooth gear in the transmission is 200 lb/ft per PTO. Therefore, the 272 Series torque ratings will be adjusted as follows: A ratio = 235 lb/ft., B ratio = 192 lb/ft., C ratio = 159 lb/ft. and D ratio = 135 lbs/ft. The 442 Series w/Pressure Lube on both sides, PTO torque ratings will be as follows, B ratio = 208 lb/ft., F ratio = 135 lb/ft. For a more precise evaluation of your PTO application refer to the Allison Body Builders Book, Section F, PTO Systems Provisions.
2. There is a torque converter lock up feature available with the 1000/2000/2400 series transmissions. The torque converter lock up feature comes on and is controlled by the Transmission Control Module (TCM) when a signal is provided to the "PTO Enable" circuit of the TCM by the PTO switch. Lock up will only come on in the "NEUTRAL" and "PARK" positions at 1100 RPM transmission turbine speed. This equates to 1200-1250 RPM or higher engine speed, depending on PTO load. The lock up clutch does not come on automatically in "DRIVE." Refer to the appropriate owner's manual for wiring installation.
3. 2019 GM 4500HD, 5500HD, 6500HD Chassis or International CV™ Series Chassis - If using the provided in-dash switch, use wiring harness 75-P-33 for either the 252 or 272 Series PTOs. This harness must be ORDERED SEPARATELY and is required for proper PTO to Engine interface operation.
4. FITMENT ISSUE - The 272G with a shaft-high (belly up) output WILL NOT fit on the 4500/5500 applications due to cab floor interference. The 272G shaft high housing may possibly fit on the 6500 chassis, but fitment must be verified before ordering PTO. Otherwise, the 272G shaft low is the only confirmed fit for all chassis.
5. For installation of PTO on right side opening, the exhaust must be temporarily removed. Please refer to the latest revision of GM Upfitter Integration Bulletin #146 ("Partial Exhaust System Removal to Enable Installation of a PTO.") available at gmupfitter.com.
6. A lube T fitting is required in the oil return cooling line to supply low pressure oil to the idler shaft of the 252, 272, or 442 Series PTO. Lube T fitting 378970 is required and must be purchased separately. Return line U-bolt may need to be removed to make installation of T fitting easier. Installer is responsible for any required modifications necessary to reinstall U-bolt.
7. 442*B Ratio - DO NOT USE with Geared Adapter.
8. Geared Adapters - 626/630/645 listed on this application page are for the 442 (F Ratio Only) or 272. 442*F Ratio - Use 442ZFHV with (1) 7-A-140 filler block and (1) 328170-94X stud kit when mounting the PTO to one of the adapters listed. 272 - Use 272L*HV (deep mount) with (1) 7-A-140 and (1) 328170-94X. Use 35-P-41 gasket between transmission and adapter. Use filler block (1) 7-A-140 between the adapter and PTO with 35-P-1 or 2 shim gaskets to obtain .006"-012" of backlash between the driver gears.
9. If the 442 Series is ordered with pressure lube, hose 328075X is supplied with the PTO. A restrictor orifice, 379896 (442*FHVP) or 379594 (442*BHVP) is required and is shipped with the PTO.
10. Limited Ratios - the K Ratio and above will not fit on this transmission due to adjacent interference with the input ratio gear. In some instances the D ratio will not fit either. There seems to be two variations of the transmission case that effect the D ratio, but we have no way to confirm which case is which.

CHELSEA

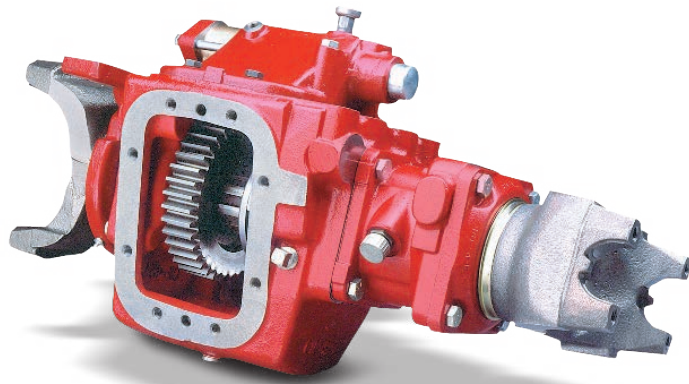

Parker | Chelsea

ENGINEERING YOUR SUCCESS.



WARNING — User Responsibility

FAILURE OR IMPROPER SELECTION OR IMPROPER USE OF THE PRODUCTS DESCRIBED HEREIN OR RELATED ITEMS CAN CAUSE DEATH, PERSONAL INJURY AND PROPERTY DAMAGE.

This document and other information from Parker Hannifin Corporation, its subsidiaries and authorized distributors provide product or system options for further investigation by users having technical expertise.

The user, through its own analysis and testing, is solely responsible for making the final selection of the system and components and assuring that all performance, endurance, maintenance, safety and warning requirements of the application are met. The user must analyze all aspects of the application, follow applicable industry standards, and follow the information concerning the product in the current product catalog and in any other materials provided from Parker or its subsidiaries or authorized distributors.

To the extent that Parker or its subsidiaries or authorized distributors provide component or system options based upon data or specifications provided by the user, the user is responsible for determining that such data and specifications are suitable and sufficient for all applications and reasonably foreseeable uses of the components or systems.

Offer of Sale

The items described in this document are hereby offered for sale by Parker Hannifin Corporation, its subsidiaries or its authorized distributors. This offer and its acceptance are governed by the provisions stated in the "Offer of Sale".



WARNING: This product can expose you to chemicals including Lead and Lead Compounds, and Di(2-ethylhexyl)phthalate (DEHP) which are known to the State of California to cause cancer and birth defects or other reproductive harm. For more information go to www.P65Warnings.ca.gov

© Copyright 2022, Parker Hannifin Corporation, All Rights Reserved

CHELSEA TRANSMISSION INDEX

Transmission Make and Model	PTO Appl. Number	Number Forward Speeds	Teeth in PTO Driver
912 AH (Uses 8-Bolt PTOs)	CHL-3	1	L39-R39
912 AH (Uses 8-Bolt PTOs)(Top)	CHL-3A	1	T39



IMPORTANT: See Safety Information in Section 1 of the Chelsea Applications catalog HY25-3000/US

Transmission PTO Driver & Apertures (Viewed from Rear of Transmission)
L-Left Side R-Right Side B-Bottom Side T-Top Side CS-Countershaft
For transmissions not listed, contact your authorized Chelsea Distributor.

CHL-3

CHELSEA



912 AH (Uses 8-Bolt PTOs)

LEFT SIDE ONLY

RIGHT SIDE ONLY

TRANSMISSION GEAR DATA:

L.S. 08-BOLT Opening Gear FORWARD of Centerline
39 Teeth - SPUR

PITCH LINE TO APERTURE FACE:
0.8100" (20.5700MM)

TRANSMISSION GEAR DATA:

R.S. 08-BOLT Opening Gear FORWARD of Centerline
39 Teeth - SPUR

PITCH LINE TO APERTURE FACE:
0.8100" (20.5700MM)

CAUTION: Application Approval Required for PTO Output Shaft Speeds Above 2500 RPM

PTO Model	Torq l / C †	Dir Rot	Engine %		Filler Block	Adapter Assy	Stud Kit	PTO Model	Torq l / C †	Dir Rot	Engine %		Filler Block	Adapter Assy	Stud Kit
			Fwd	Rev							Fwd	Rev			

ONE SPEED - TWO GEAR - MECHANICAL SHIFT

221ZCAHX-5	250 l	Eng	72		7-A-032(P)(35)	328564X	Furnished	221ZCAHX-3	250 l	Eng	72		7-A-032(P)(35)	328564X	Furnished
221ZEAHX-5	250 l	Eng	84			328564X	Furnished	221ZEAHX-3	250 l	Eng	84			328564X	Furnished
489XFAHX-5 (2)	250 l	Eng	101				Furnished	489XFAHX-3 (2)	250 l	Eng	101				Furnished
489XHAHX-5 (13)	250 l	Eng	117				Furnished	489XHAHX-3 (13)	250 l	Eng	117				Furnished
489XLAHX-5 (1)	250 l	Eng	130				Furnished	489XLAHX-3 (1)	250 l	Eng	130				Furnished
489XQAHX-5 (1)	225 l	Eng	140				Furnished	489XQAHX-3 (1)	225 l	Eng	140				Furnished
489XRAHX-5 (1)	225 l	Eng	162				Furnished	489XRAHX-3 (1)	225 l	Eng	162				Furnished
489XSAHX-5 (1)	200 l	Eng	193				Furnished	489XSAHX-3 (1)	200 l	Eng	193				Furnished
489XUAHX-5 (1)	195 l	Eng	230				Furnished	489XUAHX-3 (1)	195 l	Eng	230				Furnished
489XWAHX-5 (1)	175 l	Eng	271				Furnished	489XWAHX-3 (1)	175 l	Eng	271				Furnished
489XXAHX-5 (1)	140 l	Eng	321				Furnished	489XXAHX-3 (1)	140 l	Eng	321				Furnished
680XFAHX-5 (10)	375 l	Eng	101				Furnished	680XFAHX-3 (10)	375 l	Eng	101				Furnished
680XHAHX-5 (17)	375 l	Eng	117				Furnished	680XHAHX-3 (17)	375 l	Eng	117				Furnished
680XQAHX-5 (11)	375 l	Eng	140				Furnished	680XQAHX-3 (11)	375 l	Eng	140				Furnished
680XRAHX-5 (16)	350 l	Eng	162				Furnished	680XRAHX-3 (16)	350 l	Eng	162				Furnished
680XSAHX-5 (12)	325 l	Eng	193				Furnished	680XSAHX-3 (12)	325 l	Eng	193				Furnished
823XBAHX-5 (29)	750 l	Eng	69				Furnished	823XBAHX-3 (29)	750 l	Eng	69				Furnished
823XDAHX-5 (33)	750 l	Eng	81				Furnished	823XDAHX-3 (33)	750 l	Eng	81				Furnished
823XGAHX-5 (34)	750 l	Eng	88				Furnished	823XGAHX-3 (34)	750 l	Eng	88				Furnished
823XJAHX-5 (30)	750 l	Eng	104				Furnished	823XJAHX-3 (30)	750 l	Eng	104				Furnished
823XMAHX-5 (28)	650 l	Eng	122				Furnished	823XMAHX-3 (28)	650 l	Eng	122				Furnished
823XRAHX-5 (32)	400 l	Eng	168				Furnished	823XRAHX-3 (32)	400 l	Eng	168				Furnished
823XTKTX-5 (15)	350 l	Eng	204		8-A-165(35)		Furnished	823XTKTX-3 (15)	350 l	Eng	204		8-A-165(35)		Furnished
880XBAHX-5 (3)	500 l	Eng	69				Furnished	880XBAHX-3 (3)	500 l	Eng	69				Furnished
880XDAHX-5 (4)	500 l	Eng	81				Furnished	880XDAHX-3 (4)	500 l	Eng	81				Furnished
880XGAHX-5 (9)	500 l	Eng	88				Furnished	880XGAHX-3 (9)	500 l	Eng	88				Furnished
880XJAHX-5 (5)	500 l	Eng	104				Furnished	880XJAHX-3 (5)	500 l	Eng	104				Furnished
880XMAHX-5 (6)	500 l	Eng	122				Furnished	880XMAHX-3 (6)	500 l	Eng	122				Furnished
880XQAHX-5 (14)	450 l	Eng	142				Furnished	880XQAHX-3 (14)	450 l	Eng	142				Furnished
880XRAHX-5 (7)	400 l	Eng	168				Furnished	880XRAHX-3 (7)	400 l	Eng	168				Furnished
880XTAHX-5 (8)	350 l	Eng	217				Furnished	880XTAHX-3 (8)	350 l	Eng	217				Furnished

Continued on Next Page

† I = Intermittent Torque Only - De-rate Torque Rating 30% for Continuous Duty.

C = Continuous or Intermittent Torque - No need to De-Rate Torque Rating.

IMPORTANT: Refer to the back of this transmission section and read all notes associated with this application page. Some notes may affect the proper PTO selection.

CAUTION: Do not use 442/489 A or C ratios on Chelsea split shafts if final rotation is ENG.

- | | | | | |
|----------------------------------|-----------------------------------|-----------------------------------|-----------------------------------|--------------------------------------|
| (1) Input Gear Part No. 5-P-1004 | (6) Input Gear Part No. 5-P-1103 | (11) Input Gear Part No. 5-P-1246 | (16) Input Gear Part No. 5-P-1441 | (32) Input Gear Part No. 5-P-721 |
| (2) Input Gear Part No. 5-P-1077 | (7) Input Gear Part No. 5-P-1104 | (12) Input Gear Part No. 5-P-1322 | (17) Input Gear Part No. 5-P-1494 | (33) Input Gear Part No. 5-P-971 |
| (3) Input Gear Part No. 5-P-1100 | (8) Input Gear Part No. 5-P-1105 | (13) Input Gear Part No. 5-P-1364 | (28) Input Gear Part No. 5-P-283 | (34) Input Gear Part No. 5-P-980 |
| (4) Input Gear Part No. 5-P-1101 | (9) Input Gear Part No. 5-P-1135 | (14) Input Gear Part No. 5-P-1385 | (29) Input Gear Part No. 5-P-285 | (35) Filler block furnished with PTO |
| (5) Input Gear Part No. 5-P-1102 | (10) Input Gear Part No. 5-P-1242 | (15) Input Gear Part No. 5-P-1395 | (30) Input Gear Part No. 5-P-325 | |

CHELSEA®

CHELSEA

CHL-3

912 AH (Uses 8-Bolt PTOs)

LEFT SIDE ONLY

RIGHT SIDE ONLY

TRANSMISSION GEAR DATA:

L.S. 08-BOLT Opening Gear FORWARD of Centerline
39 Teeth - SPUR

PITCH LINE TO APERTURE FACE:

0.8100" (20.5700MM)

TRANSMISSION GEAR DATA:

R.S. 08-BOLT Opening Gear FORWARD of Centerline
39 Teeth - SPUR

PITCH LINE TO APERTURE FACE:

0.8100" (20.5700MM)

CAUTION: Application Approval Required for PTO Output Shaft Speeds Above 2500 RPM

PTO Model	Torq I / C †	Dir Rot	Engine %		Filler Block	Adapter Assy	Stud Kit	PTO Model	Torq I / C †	Dir Rot	Engine %		Filler Block	Adapter Assy	Stud Kit
			Fwd	Rev							Fwd	Rev			
ONE SPEED - TWO GEAR POWERSHIFT (AIR OR HYDRAULIC)															
272XAAJX-*5 (27)	300 C	Eng	56		7-A-032(P)	328481X	Furnished	272XAAJX-*3 (27)	300 C	Eng	56		7-A-032(P)	328481X	Furnished
282XBAJX-*5 (18)	250 C	Eng	69		8-A-032		Furnished	282XBAJX-*3 (18)	250 C	Eng	69		8-A-032		Furnished
282XCAJX-*5 (19)	250 C	Eng	83		8-A-032		Furnished	282XCAJX-*3 (19)	250 C	Eng	83		8-A-032		Furnished
282XDAJX-*5 (20)	250 C	Eng	99		8-A-032		Furnished	282XDAJX-*3 (20)	250 C	Eng	99		8-A-032		Furnished
282XGAJX-*5 (21)	250 C	Eng	118		8-A-032		Furnished	282XGAJX-*3 (21)	250 C	Eng	118		8-A-032		Furnished
282XKAJX-*5 (22)	250 C	Eng	132		8-A-032		Furnished	282XKAJX-*3 (22)	250 C	Eng	132		8-A-032		Furnished
282XMAJX-*5 (23)	250 C	Eng	148		8-A-032		Furnished	282XMAJX-*3 (23)	250 C	Eng	148		8-A-032		Furnished
282XPAJX-*5 (24)	250 C	Eng	165		8-A-032		Furnished	282XPAJX-*3 (24)	250 C	Eng	165		8-A-032		Furnished
282XSAJX-*5 (25)	225 C	Eng	184		8-A-032		Furnished	282XSAJX-*3 (25)	225 C	Eng	184		8-A-032		Furnished
282XTAJX-*5 (26)	225 C	Eng	206		8-A-032		Furnished	282XTAJX-*3 (26)	225 C	Eng	206		8-A-032		Furnished
ONE SPEED - TWO GEAR - POWERSHIFT (AIR)															
885XBAHX-*5 (3)	500 I	Eng	69				Furnished	885XBAHX-*3 (3)	500 I	Eng	69				Furnished
885XGAHX-*5 (9)	500 I	Eng	88				Furnished	885XGAHX-*3 (9)	500 I	Eng	88				Furnished
885XJAHX-*5 (5)	500 I	Eng	104				Furnished	885XJAHX-*3 (5)	500 I	Eng	104				Furnished
885XMAHX-*5 (6)	500 I	Eng	122				Furnished	885XMAHX-*3 (6)	500 I	Eng	122				Furnished
ONE SPEED - FORWARD & REVERSE															
348XFAHX-*5 (31)	200 I	Eng	88	92			Furnished	348XFAHX-*5 (31)	200 I	Eng	88	92			Furnished
863XBAHX-*5	500 I	Eng	69	85			Furnished	863XBAHX-*5	500 I	Eng	69	85			Furnished
GEARED ADAPTERS															
628XAHX-4AH	250 I	Opp					Furnished	628XAHX-3AH	250 I	Opp					Furnished

† I = Intermittent Torque Only - De-rate Torque Rating 30% for Continuous Duty.

C = Continuous or Intermittent Torque - No need to De-Rate Torque Rating.

IMPORTANT: Refer to the back of this transmission section and read all notes associated with this application page. Some notes may affect the proper PTO selection.

CAUTION: Do not use 442/489 A or C ratios on Chelsea split shafts if final rotation is ENG.

(3) Input Gear Part No. 5-P-1100 (19) Input Gear Part No. 5-P-1510-12X (24) Input Gear Part No. 5-P-1510-17X
 (5) Input Gear Part No. 5-P-1102 (20) Input Gear Part No. 5-P-1510-13X (25) Input Gear Part No. 5-P-1510-18X
 (6) Input Gear Part No. 5-P-1103 (21) Input Gear Part No. 5-P-1510-14X (26) Input Gear Part No. 5-P-1510-19X
 (9) Input Gear Part No. 5-P-1135 (22) Input Gear Part No. 5-P-1510-15X (27) Input Gear Part No. 5-P-1510-1X
 (18) Input Gear Part No. 5-P-1510-11X (23) Input Gear Part No. 5-P-1510-16X (31) Input Gear Part No. 5-P-581

CHL-3A

CHELSEA



912 AH (Uses 8-Bolt PTOs)(Top)

TOP SIDE ONLY

TRANSMISSION GEAR DATA:
TOP 08-BOLT Opening Gear FORWARD of Centerline
39 Teeth - SPUR
PITCH LINE TO APERTURE FACE:
0.8100" (20.5700MM)

CAUTION: Application Approval Required for PTO Output Shaft Speeds Above 2500 RPM

PTO Model	Torq	Dir Rot	Engine %		Filler Block	Adapter Assy	Stud Kit	PTO Model	Torq	Dir Rot	Engine %		Filler Block	Adapter Assy	Stud Kit
	I / C †		Fwd	Rev					I / C †		Fwd	Rev			

ONE SPEED - TWO GEAR - MECHANICAL SHIFT

489XFAHP-*3 (2)	250 I	Eng	101				Furnished
489XHAHP-*3 (13)	250 I	Eng	117				Furnished
489XLAHP-*3 (1)	250 I	Eng	130				Furnished
489XQAHP-*3 (1)	225 I	Eng	140				Furnished
489XRAHP-*3 (1)	225 I	Eng	162				Furnished
489XSAHP-*3 (1)	200 I	Eng	193				Furnished
489XUAHP-*3 (1)	195 I	Eng	230				Furnished
489XWAHP-*3 (1)	175 I	Eng	271				Furnished
489XXAHP-*3 (1)	140 I	Eng	321				Furnished
680XFAHP-*3 (10)	375 I	Eng	101				Furnished
680XHAHP-*3 (16)	375 I	Eng	117				Furnished
680XQAHP-*3 (11)	375 I	Eng	140				Furnished
680XRAHP-*3 (15)	350 I	Eng	350				Furnished
680XSAHP-*3 (12)	325 I	Eng	193				Furnished
880XBAHP-*3 (3)	500 I	Eng	69				Furnished
880XDAHP-*3 (4)	500 I	Eng	81				Furnished
880XGAHP-*3 (9)	500 I	Eng	88				Furnished
880XJAHP-*3 (5)	500 I	Eng	104				Furnished
880XMAHP-*3 (6)	500 I	Eng	122				Furnished
880XQAHP-*3 (14)	450 I	Eng	142				Furnished
880XRAHP-*3 (7)	400 I	Eng	168				Furnished
880XTAHP-*3 (8)	350 I	Eng	217				Furnished

† I = Intermittent Torque Only - De-rate Torque Rating 30% for Continuous Duty.

C = Continuous or Intermittent Torque - No need to De-Rate Torque Rating.

IMPORTANT: Refer to the back of this transmission section and read all notes associated with this application page. Some notes may affect the proper PTO selection.

CAUTION: Do not use 442/489 A or C ratios on Chelsea split shafts if final rotation is ENG.

- (1) Input Gear Part No. 5-P-1004
- (2) Input Gear Part No. 5-P-1077
- (3) Input Gear Part No. 5-P-1100
- (4) Input Gear Part No. 5-P-1101
- (5) Input Gear Part No. 5-P-1102
- (6) Input Gear Part No. 5-P-1103
- (7) Input Gear Part No. 5-P-1104
- (8) Input Gear Part No. 5-P-1105
- (9) Input Gear Part No. 5-P-1135
- (10) Input Gear Part No. 5-P-1242
- (11) Input Gear Part No. 5-P-1246
- (12) Input Gear Part No. 5-P-1322
- (13) Input Gear Part No. 5-P-1364
- (14) Input Gear Part No. 5-P-1385
- (15) Input Gear Part No. 5-P-1441
- (16) Input Gear Part No. 5-P-1494

Chelsea

Chelsea Notes

CHL-3

1. If two or three 8-Bolt PTOs are to be mounted on split shaft use stud kit 328170-190X to prevent thread interference.
 2. The AK & XK output flanges can not be used with the A & C ratios on the 489 Series PTOs due to mounting stud interference. Use a RA or RB rotatable flange for the XK and the RA for the AK flange.
 3. 272/282 Series-Must be used as an AIR Shift PTO. Order Air Shift Options Only
-

CHL-3A

1. PTOs for this application must be ordered with L output designator for self lube option. EX: 442XFAHP-W3LD for self lube with a 1.25" std. output.
2. Pressure lube installation kits must be ordered separately. 880 Series PTOs use kit 329110-1X, all other models use 329110X.
3. If two or three 8-Bolt PTOs are to be mounted on split shaft, use stud kit 328170-190X to prevent thread interference.
4. The AK & XK output flanges cannot be used with the A & C ratios on the 489 Series PTOs due to mounting stud interference. Use a RA or RB rotatable flange for the XK and the RA for the AK flange.



DODGE/RAM

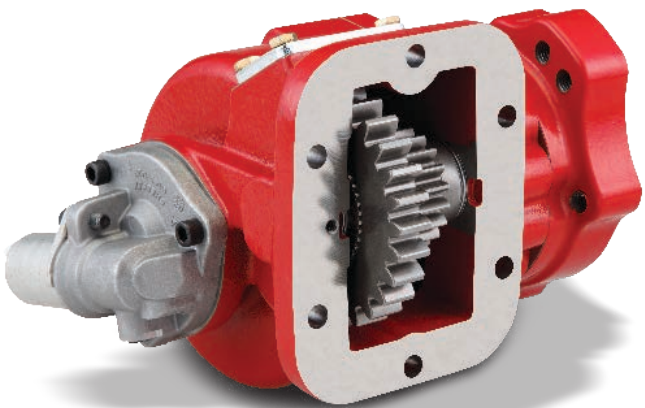
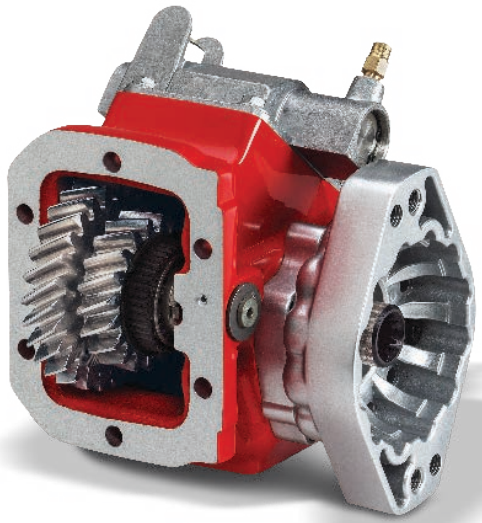
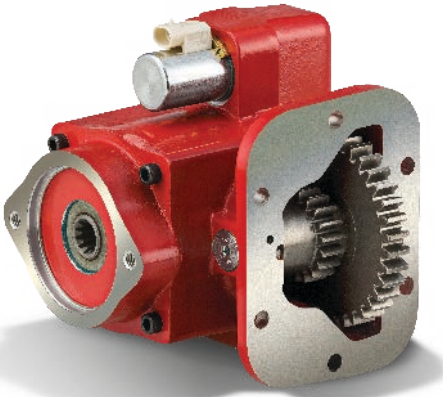

Parker | Chelsea

ENGINEERING YOUR SUCCESS.

**WARNING — User Responsibility**

FAILURE OR IMPROPER SELECTION OR IMPROPER USE OF THE PRODUCTS DESCRIBED HEREIN OR RELATED ITEMS CAN CAUSE DEATH, PERSONAL INJURY AND PROPERTY DAMAGE.

This document and other information from Parker Hannifin Corporation, its subsidiaries and authorized distributors provide product or system options for further investigation by users having technical expertise.

The user, through its own analysis and testing, is solely responsible for making the final selection of the system and components and assuring that all performance, endurance, maintenance, safety and warning requirements of the application are met. The user must analyze all aspects of the application, follow applicable industry standards, and follow the information concerning the product in the current product catalog and in any other materials provided from Parker or its subsidiaries or authorized distributors.

To the extent that Parker or its subsidiaries or authorized distributors provide component or system options based upon data or specifications provided by the user, the user is responsible for determining that such data and specifications are suitable and sufficient for all applications and reasonably foreseeable uses of the components or systems.

Offer of Sale

The items described in this document are hereby offered for sale by Parker Hannifin Corporation, its subsidiaries or its authorized distributors. This offer and its acceptance are governed by the provisions stated in the "Offer of Sale".



WARNING: This product can expose you to chemicals including Lead and Lead Compounds, and Di(2-ethylhexyl)phthalate (DEHP) which are known to the State of California to cause cancer and birth defects or other reproductive harm. For more information go to www.P65Warnings.ca.gov

© Copyright 2022, Parker Hannifin Corporation, All Rights Reserved

DODGE/RAM TRANSMISSION INDEX

Transmission Make and Model	PTO Appl. Number	Number Forward Speeds	Teeth in PTO Driver
AS66RC (MY2014 & Later) Gas	DDG-3	6	L69-R69
AS68RC (MY2010 & Prior)	DDG-1	6	R69
AS68RC (MY2011 & 2012)	DDG-1A	6	R69
AS69RC (MY2013 and Later) Diesel	DDG-3	6	L69-R69
G56 Dodge/RAM/Sterling Cab Chassis (Manual) - 4X2 ONLY	DDG-2	6	L52-R52



IMPORTANT: See Safety Information in Section 1 of the Chelsea Applications catalog HY25-3000/US

Transmission PTO Driver & Apertures (Viewed from Rear of Transmission)
L-Left Side R-Right Side B-Bottom Side T-Top Side CS-Countershaft
For transmissions not listed, contact your authorized Chelsea Distributor.

DDG-1

DODGE/RAM

CHELSEA®

AS68RC (MY2010 & Prior)

RIGHT SIDE ONLY

TRANSMISSION GEAR DATA:

R.S. 06-BOLT Opening Gear FORWARD of Centerline
69 Teeth - SPUR

PITCH LINE TO APERTURE FACE:

1.1200" (28.4480MM)

CAUTION: Application Approval Required for PTO Output Shaft Speeds Above 2500 RPM

PTO Model	Torq	Dir Rot	Engine %		Filler Block	Adapter Assy	Stud Kit	PTO Model	Torq	Dir Rot	Engine %		Filler Block	Adapter Assy	Stud Kit
	I / C †		Fwd	Rev					I / C †		Fwd	Rev			

ONE SPEED - TWO GEAR POWERSHIFT (AIR OR HYDRAULIC)

272DAKUP-*3 (3)	196 C	Eng	69												Furnished
272DBKUP-*3 (4)	160 C	Eng	84												Furnished
272DCKUP-*3 (5)	132 C	Eng	102												Furnished
272DDKUP-*3 (6)	111 C	Eng	122												Furnished

ONE SPEED - TWO GEAR - POWERSHIFT (HYDRAULIC)

252DDKUX-*5 (1)	85 I	Eng	99												Furnished
252DMKUX-*5 (2)	50 I	Eng	144												Furnished

See next page for more pump options.

Continued on Next Page

† I = Intermittent Torque Only - De-rate Torque Rating 30% for Continuous Duty.

C = Continuous or Intermittent Torque - No need to De-Rate Torque Rating.

IMPORTANT: Refer to the back of this transmission section and read all notes associated with this application page. Some notes may affect the proper PTO selection.

CAUTION: 2010 + Prior - Chelsea Wiring Harness 329457X is used for the 270D The 329621X is used for the 252D and 272D. This will Allow the OBD II Monitoring System to be Disabled while the PTO System is being Operated. This will Prevent "False" Lighting of the "Check Engine" Lamp due to the Engine-PTO Driven Accessories.

- (1) Input Gear Part No. 5-P-1427 (6) Input Gear Part No. 5-P-1515-4X
 (2) Input Gear Part No. 5-P-1437
 (3) Input Gear Part No. 5-P-1515-1X
 (4) Input Gear Part No. 5-P-1515-2X
 (5) Input Gear Part No. 5-P-1515-3X

CHELSEA®

DODGE/RAM

DDG-1

AS68RC (MY2010 & Prior)

RIGHT SIDE ONLY

TRANSMISSION GEAR DATA:

R.S. 06-BOLT Opening Gear FORWARD of Centerline
69 Teeth - SPUR

PITCH LINE TO APERTURE FACE:

1.1200" (28.4480MM)

Pump Option Charts

252 Pumps offered in the PGP511 (5/8" - 9T / SAE A Flange – XE Output)

Option Order Code	Chelsea Pump Model	Displacement in ³ /rev	Displacement Gal/rev	Max Pressure PSI	Max Speed RPM	Shaft Size	Porting	
							Inlet	Outlet
1116	CGP-P11C016-1AC	0.37	0.003	3988	3500	5/8" - 9T	SAE12	SAE10
1121	CGP-P11C021-1AC	0.49	0.002	3988	4000	5/8" - 9T	SAE12	SAE10
1126	CGP-P11C026-1AC	0.61	0.003	3988	3600	5/8" - 9T	SAE12	SAE10
1129	CGP-P11C029-1AC	0.67	0.003	3988	3600	5/8" - 9T	SAE12	SAE10
1137	CGP-P11C037-1AC	0.85	0.004	3988	3300	5/8" - 9T	SAE12	SAE10
1449	CGP-P31C054-1AE	1.24	0.005	3500	3000	5/8" - 9T	SAE16	SAE10
1462	CGP-P31C061-1AE	1.40	0.006	3500	3000	5/8" - 9T	SAE16	SAE10

252 Pumps offered in the PGP511 (3/4" - 11T / SAE A Flange – AD Output)

Option Order Code	Chelsea Pump Model	Displacement in ³ /rev	Displacement Gal/rev	Max Pressure PSI	Max Speed RPM	Shaft Size	Porting	
							Inlet	Outlet
P37	CGP-P11C037-5AC	0.85	0.004	3988	3300	3/4" - 11T	SAE12	SAE10
P42	CGP-P11C042-5AC	0.98	0.004	3988	3000	3/4" - 11T	SAE12	SAE10
P55	CGP-P11C055-5AC	1.28	0.006	3408	2800	3/4" - 11T	SAE12	SAE10
P71	CGP-P11C071-5AC	1.65	0.007	2900	2400	3/4" - 11T	SAE12	SAE10
P82	CGP-P11C082-5AC	1.89	0.008	2465	2300	3/4" - 11T	SAE12	SAE10

Dodge/RAM

DDG-1A

DODGE/RAM

CHELSEA®

AS68RC (MY2011 & 2012)

RIGHT SIDE ONLY

TRANSMISSION GEAR DATA:

R.S. 06-BOLT Opening Gear FORWARD of Centerline
69 Teeth - SPUR

PITCH LINE TO APERTURE FACE:

1.1200" (28.4480MM)

CAUTION: Application Approval Required for PTO Output Shaft Speeds Above 2500 RPM

PTO Model	Torq	Dir Rot	Engine %		Filler Block	Adapter Assy	Stud Kit	PTO Model	Torq	Dir Rot	Engine %		Filler Block	Adapter Assy	Stud Kit
	I / C †		Fwd	Rev					I / C †		Fwd	Rev			

ONE SPEED - TWO GEAR POWERSHIFT (AIR OR HYDRAULIC)

272RAKUP-*3 (3)	196 C	Eng	69												Furnished
272RBKUP-*3 (4)	160 C	Eng	84												Furnished
272RCKUP-*3 (5)	132 C	Eng	102												Furnished
272RDKUP-*3 (6)	111 C	Eng	122												Furnished

ONE SPEED - TWO GEAR - POWERSHIFT (HYDRAULIC)

252RDKUX-*5 (1)	85 I	Eng	99												Furnished
252RMKUX-*5 (2)	50 I	Eng	144												Furnished

See next page for more pump options.

Continued on Next Page

† I = Intermittent Torque Only - De-rate Torque Rating 30% for Continuous Duty.

C = Continuous or Intermittent Torque - No need to De-Rate Torque Rating.

IMPORTANT: Refer to the back of this transmission section and read all notes associated with this application page. Some notes may affect the proper PTO selection.

CAUTION: It is Required for MY2011/12 Trucks, the 252R & 272R use Wiring Harness (329663X) and the 270R use (329664X). This will allow the OBD II Monitoring System to be Disabled while the PTO System is being Operated. This will Prevent "False" Lighting of the "Check Engine" Lamp due to the Engine-PTO Driven Accessories.

- (1) Input Gear Part No. 5-P-1427 (6) Input Gear Part No. 5-P-1515-4X
 (2) Input Gear Part No. 5-P-1437
 (3) Input Gear Part No. 5-P-1515-1X
 (4) Input Gear Part No. 5-P-1515-2X
 (5) Input Gear Part No. 5-P-1515-3X

CHELSEA®

DODGE/RAM

DDG-1A

AS68RC (MY2011 & 2012)

RIGHT SIDE ONLY

TRANSMISSION GEAR DATA:

R.S. 06-BOLT Opening Gear FORWARD of Centerline
69 Teeth - SPUR

PITCH LINE TO APERTURE FACE:

1.1200" (28.4480MM)

Pump Option Charts

252 Pumps offered in the PGP511 (5/8" - 9T / SAE A Flange – XE Output)

Option Order Code	Chelsea Pump Model	Displacement in ³ /rev	Displacement Gal/rev	Max Pressure PSI	Max Speed RPM	Shaft Size	Porting	
							Inlet	Outlet
1116	CGP-P11C016-1AC	0.37	0.003	3988	3500	5/8" - 9T	SAE12	SAE10
1121	CGP-P11C021-1AC	0.49	0.002	3988	4000	5/8" - 9T	SAE12	SAE10
1126	CGP-P11C026-1AC	0.61	0.003	3988	3600	5/8" - 9T	SAE12	SAE10
1129	CGP-P11C029-1AC	0.67	0.003	3988	3600	5/8" - 9T	SAE12	SAE10
1137	CGP-P11C037-1AC	0.85	0.004	3988	3300	5/8" - 9T	SAE12	SAE10
1449	CGP-P31C054-1AE	1.24	0.005	3500	3000	5/8" - 9T	SAE16	SAE10
1462	CGP-P31C061-1AE	1.40	0.006	3500	3000	5/8" - 9T	SAE16	SAE10

252 Pumps offered in the PGP511 (3/4" - 11T / SAE A Flange – AD Output)

Option Order Code	Chelsea Pump Model	Displacement in ³ /rev	Displacement Gal/rev	Max Pressure PSI	Max Speed RPM	Shaft Size	Porting	
							Inlet	Outlet
P37	CGP-P11C037-5AC	0.85	0.004	3988	3300	3/4" - 11T	SAE12	SAE10
P42	CGP-P11C042-5AC	0.98	0.004	3988	3000	3/4" - 11T	SAE12	SAE10
P55	CGP-P11C055-5AC	1.28	0.006	3408	2800	3/4" - 11T	SAE12	SAE10
P71	CGP-P11C071-5AC	1.65	0.007	2900	2400	3/4" - 11T	SAE12	SAE10
P82	CGP-P11C082-5AC	1.89	0.008	2465	2300	3/4" - 11T	SAE12	SAE10

Dodge/RAM

DDG-2

DODGE/RAM

CHELSEA®

G56 Dodge/RAM/Sterling Cab Chassis (Manual) -
4X2 ONLY

LEFT SIDE ONLY

TRANSMISSION GEAR DATA:

L.S. 06-BOLT Opening Gear REAR of Centerline
52 Teeth - R.H. HELIX

PITCH LINE TO APERTURE FACE:

1.3760" (35.0000MM)

CAUTION: Application Approval Required for PTO Output Shaft Speeds Above 2500 RPM

PTO Model	Torq	Dir Rot	Engine %		Filler Block	Adapter Assy	Stud Kit	PTO Model	Torq	Dir Rot	Engine %		Filler Block	Adapter Assy	Stud Kit
	I / C †		Fwd	Rev					I / C †		Fwd	Rev			

ONE SPEED - TWO GEAR - MECHANICAL SHIFT

442LLKH-X*6 (1)	250 I	Opp	67				7170-72X
442LQKH-X*6 (1)	225 I	Opp	72				7170-72X
442LRKH-X*6 (1)	225 I	Opp	84				7170-72X
442LSKH-X*6 (1)	200 I	Opp	100				7170-72X
442LUKH-X*6 (1)	195 I	Opp	119				7170-72X
442LWKH-X*6 (1)	175 I	Opp	140				7170-72X
442LXKH-X*6 (1)	140 I	Opp	165				7170-72X

† I = Intermittent Torque Only - De-rate Torque Rating 30% for Continuous Duty.

C = Continuous or Intermittent Torque - No need to De-Rate Torque Rating.

IMPORTANT: Refer to the back of this transmission section and read all notes associated with this application page. Some notes may affect the proper PTO selection.**CAUTION:** For Dodge Model Years 2007-2010 Chelsea Wiring Harness 329460X and for RAM Model Years 2011 and Later Chelsea Wiring Harness 329749X Must be Used to Complete the Installation (Order Separately). This will allow the ODB II Monitoring System to be Disabled While the PTO System is being Operated.

(1) Input Gear Part No. 5-P-1343

CHELSEA®

DODGE/RAM

DDG-3

AS66RC (MY2014 & Later) Gas
AS69RC (MY2013 and Later) Diesel

RIGHT SIDE ONLY

TRANSMISSION GEAR DATA:

R.S. 06-BOLT Opening Gear FORWARD of Centerline
69 Teeth - SPUR

PITCH LINE TO APERTURE FACE:

1.1200" (28.4480MM)

CAUTION: Application Approval Required for PTO Output Shaft Speeds Above 2500 RPM

PTO Model	Torq	Dir Rot	Engine %		Filler Block	Adapter Assy	Stud Kit	PTO Model	Torq	Dir Rot	Engine %		Filler Block	Adapter Assy	Stud Kit
	I / C †		Fwd	Rev					I / C †		Fwd	Rev			

ONE SPEED - TWO GEAR POWERSHIFT (AIR OR HYDRAULIC)

272RAKUP-*3 (3)	300 C	Eng	69												Furnished
272RBKUP-*3 (4)	296 C	Eng	84												Furnished
272RCKUP-*3 (5)	245 C	Eng	102												Furnished
272RDKUP-*3 (6)	205 C	Eng	122												Furnished
272RGKUP-*3 (7)	173 C	Eng	145												Furnished
272RKKUP-*3 (8)	154 C	Eng	162												Furnished

ONE SPEED - TWO GEAR - POWERSHIFT (HYDRAULIC)

252RDKUX-*5 (1)	85 I	Eng	99												Furnished
252RMKUX-*5 (2)	50 I	Eng	144												Furnished

See next page for more pump options.

Continued on Next Page

† I = Intermittent Torque Only - De-rate Torque Rating 30% for Continuous Duty.

C = Continuous or Intermittent Torque - No need to De-Rate Torque Rating.

IMPORTANT: Refer to the back of this transmission section and read all notes associated with this application page. Some notes may affect the proper PTO selection.

WARNING: RATIO LIMITATIONS - Due to gear interference in the aperture of the transmissions, RAM applications are limited to A thru K.

CAUTION: It is Required for MY2011/12 Trucks, the 252R & 272R use Wiring Harness (329663X) and the 270R use (329664X). This will allow the ODB II Monitoring System to be Disabled while the PTO System is being Operated. This will Prevent "False" Lighting of the "Check Engine" Lamp due to the Engine-PTO Driven Accessories.

(1) Input Gear Part No. 5-P-1427
(2) Input Gear Part No. 5-P-1437
(3) Input Gear Part No. 5-P-1515-1X
(4) Input Gear Part No. 5-P-1515-2X
(5) Input Gear Part No. 5-P-1515-3X

(6) Input Gear Part No. 5-P-1515-4X
(7) Input Gear Part No. 5-P-1515-5X
(8) Input Gear Part No. 5-P-1515-6X

DDG-3

DODGE/RAM

CHELSEA®

AS66RC (MY2014 & Later) Gas
AS69RC (MY2013 and Later) Diesel

RIGHT SIDE ONLY

TRANSMISSION GEAR DATA:

R.S. 06-BOLT Opening Gear FORWARD of Centerline
69 Teeth - SPUR

PITCH LINE TO APERTURE FACE:

1.1200" (28.4480MM)

Pump Option Charts

252 Pumps offered in the PGP511 (5/8" - 9T / SAE A Flange – XE Output)

Option Order Code	Chelsea Pump Model	Displacement in ³ /rev	Displacement Gal/rev	Max Pressure PSI	Max Speed RPM	Shaft Size	Porting	
							Inlet	Outlet
1116	CGP-P11C016-1AC	0.37	0.003	3988	3500	5/8" - 9T	SAE12	SAE10
1121	CGP-P11C021-1AC	0.49	0.002	3988	4000	5/8" - 9T	SAE12	SAE10
1126	CGP-P11C026-1AC	0.61	0.003	3988	3600	5/8" - 9T	SAE12	SAE10
1129	CGP-P11C029-1AC	0.67	0.003	3988	3600	5/8" - 9T	SAE12	SAE10
1137	CGP-P11C037-1AC	0.85	0.004	3988	3300	5/8" - 9T	SAE12	SAE10
1449	CGP-P31C054-1AE	1.24	0.005	3500	3000	5/8" - 9T	SAE16	SAE10
1462	CGP-P31C061-1AE	1.40	0.006	3500	3000	5/8" - 9T	SAE16	SAE10

252 Pumps offered in the PGP511 (3/4" - 11T / SAE A Flange – AD Output)

Option Order Code	Chelsea Pump Model	Displacement in ³ /rev	Displacement Gal/rev	Max Pressure PSI	Max Speed RPM	Shaft Size	Porting	
							Inlet	Outlet
P37	CGP-P11C037-5AC	0.85	0.004	3988	3300	3/4" - 11T	SAE12	SAE10
P42	CGP-P11C042-5AC	0.98	0.004	3988	3000	3/4" - 11T	SAE12	SAE10
P55	CGP-P11C055-5AC	1.28	0.006	3408	2800	3/4" - 11T	SAE12	SAE10
P71	CGP-P11C071-5AC	1.65	0.007	2900	2400	3/4" - 11T	SAE12	SAE10
P82	CGP-P11C082-5AC	1.89	0.008	2465	2300	3/4" - 11T	SAE12	SAE10

Dodge/RAM

Dodge/RAM Notes

DDG-1

1. The PTO output shaft torque ratings are based on the maximum allowable torque at the 69 tooth transmission gear of 135 lb-ft
2. Limited Ratios - The 272*D Ratio is the fastest ratio available due to adjacent gear interference in the transmission.
3. When ordering one of the listed PTOs, Hose Kit, Wire Harness Kit and Metric Stud Kit are furnished with the PTO. The hose, wire harness and metric stud kits are required for completing the PTO installation.
4. To install one of the listed PTOs on this truck the exhaust pipe and transmission support must be dropped or installed through the passenger side floor "cut out". An OEM installed passenger side floor pan modification "Bulge" cut out must be installed. Order Mopar #82211579 "Patch Panel" Installation Kit if not Installed. Refer to Dodge Body Builders web site for complete details under "Chassis cab PTO Operation & Installation Guide-PTO Installation Alternative".

DDG-1A

1. For MY2011/12 and later RAM Cab Chassis Trucks, the torque converter locks up at an ENGINE Speed of 1200 RPM and stays on for PTO function to a maximum ENGINE Speed of 2000 RPM. The torque converter will unlock at an ENGINE Speed below 1000 RPM. The default PTO operation ENGINE speed is 900 RPM. Refer to Dodge Body Builders web site for details on raising the ENGINE speeds for PTO operation.
2. The PTO output shaft torque ratings are based on the maximum allowable torque at the 69 tooth transmission gear of 135 lb-ft
3. To install the one of the listed PTOs on this truck the exhaust pipe and transmission support must be dropped or installed through the passenger side floor "cut out". An OEM installed passenger side floor pan modification "Bulge" cut out must be installed. Order Mopar #82211579 "Patch Panel" Installation Kit if not Installed. Refer to Dodge Body Builders web site for complete details under "Chassis cab PTO Operation & Installation Guide-PTO Installation Alternative".
4. When ordering one of the listed PTOs; Hose Kit, Wire Harness Kit and Metric Stud Kit are furnished with the PTO. The hose, wire harness and metric stud kits are required for completing the PTO installation.

DDG-2

1. PTOs will not fit on 4 x 4 Dodge/Sterling 3500/4500/5500 Series Vehicles.
2. PTOs are shown in the Standard Arrangements with the PTO Housing "Bulge" Down and the Output Shaft to the rear of the vehicle. Other arrangements may be needed to install PTO/Pump applications due to the transmission cross member support interfering with pump installations to the rear of the vehicle.

DDG-3

1. The PTO Output shaft torque ratings are based on the maximum allowable torque at the 69 tooth transmission gear of 250 lb-ft
2. To install one of the listed PTOs on the RIGHT SIDE, the truck exhaust pipe and transmission support must be dropped or installed through the passenger side floor "cut out." An OEM installed passenger side floor pan modification "Bulge" cut out must be installed. Order Mopar #82211579 "Patch Panel" Installation Kit if not Installed. Refer to Dodge Body Builders web site for complete details under "Chassis cab PTO Operation & Installation Guide-PTO Installation Alternative."
3. For MY2013 and later RAM Cab Chassis Trucks, the torque converter locks up at an ENGINE Speed of 1200 RPM and stays on for PTO function to a maximum ENGINE Speed of 2000 RPM. The torque converter will unlock at an ENGINE Speed below 1000 RPM. The default PTO operation ENGINE speed is 900 RPM. Refer to Dodge Body Builders web site for details on raising the ENGINE speeds for PTO operation.
4. When ordering one of the PTOs listed above, the Hose Kit, Wire Harness Kit, and Metric Stud Kit are furnished with the PTO. All of these components are required for completing the PTO installation.



EATON FULLER



Parker | Chelsea

ENGINEERING YOUR SUCCESS.



WARNING — User Responsibility

FAILURE OR IMPROPER SELECTION OR IMPROPER USE OF THE PRODUCTS DESCRIBED HEREIN OR RELATED ITEMS CAN CAUSE DEATH, PERSONAL INJURY AND PROPERTY DAMAGE.

This document and other information from Parker Hannifin Corporation, its subsidiaries and authorized distributors provide product or system options for further investigation by users having technical expertise.

The user, through its own analysis and testing, is solely responsible for making the final selection of the system and components and assuring that all performance, endurance, maintenance, safety and warning requirements of the application are met. The user must analyze all aspects of the application, follow applicable industry standards, and follow the information concerning the product in the current product catalog and in any other materials provided from Parker or its subsidiaries or authorized distributors.

To the extent that Parker or its subsidiaries or authorized distributors provide component or system options based upon data or specifications provided by the user, the user is responsible for determining that such data and specifications are suitable and sufficient for all applications and reasonably foreseeable uses of the components or systems.

Offer of Sale

The items described in this document are hereby offered for sale by Parker Hannifin Corporation, its subsidiaries or its authorized distributors. This offer and its acceptance are governed by the provisions stated in the "Offer of Sale".



WARNING: This product can expose you to chemicals including Lead and Lead Compounds, and Di(2-ethylhexyl)phthalate (DEHP) which are known to the State of California to cause cancer and birth defects or other reproductive harm. For more information go to www.P65Warnings.ca.gov

© Copyright 2022, Parker Hannifin Corporation, All Rights Reserved

Transmission/Chelsea Power Take-Offs Torque Capacities

Eaton Transmissions has recently reviewed the maximum allowable torque ratings on the heavy duty transmissions PTO driver gear. These limits are the maximum allowable torque ratings that are not to be exceeded under any operating conditions. The following Eaton transmissions are affected by this new torque limit, all FA/FO, FR/FRO and all RT/RTO/RTLO.

1. FA/FO, FR/FRO Transmissions have the HD main shaft bearing factory installed. The maximum torque rating for the transmission PTO gear is 750 lb-ft intermittent and 500 lb-ft continuous.

FR/FRO Application Pages

FLR-88	FLR-90	FLR-91
--------	--------	--------

FA/FO Application Pages

FLR-105	FLR-106	FLR-107	FLR-111	FLR-112
---------	---------	---------	---------	---------

2. RT/RTO/RTLO Transmissions can come with a Standard (350 lb-ft) Main Shaft Bearing or a Heavy Duty (750 lb-ft) Main Shaft Bearing. The Standard Bearing is capable of 350 lb-ft Intermittent or Continuous Duty. The Heavy Duty Bearing is rated for 750 lb-ft Intermittent or 500 lb-ft Continuous Duty.

NOTE: It is the responsibility of the installer to verify which main shaft bearing is installed in the transmission.

RT/RTO/RTLO Application Pages

FLR-34	FLR-37	FLR-43	FLR-46	FLR-49	FLR-59	FLR-80	FLR-85	FLR-99
FLR-35	FLR-38	FLR-44	FLR-47	FLR-57	FLR-61	FLR-81	FLR-87	
FLR-36	FLR-39	FLR-45	FLR-48	FLR-58	FLR-64	FLR-82	FLR-98	

Using the Torque Limit Charts

- The torque charts on the following pages will help you determine the correct torque limits for your application. Listed are the standard Chelsea torque values for each series/speed ratio and the new values under the Eaton guidelines for the FA/FO, FR/FRO and RT/RTO/RTLO HD transmissions.
- If you have a RT/RTO/RTLO transmission with the roller type heavy duty input bearing (Eaton part number 4301417) the charts on the following pages will provide you with the torque values for each PTO Series/speed ratio.
- Continuous torque ratings are also listed for series and PTO speed ratios. In some cases these values will be the same as the intermittent value, which is because the new continuous rating is still below the Chelsea standard continuous rating for the PTO and does not exceed the transmission drive gear rating.
- Refer to the Input Shaft Bearing Matrix on page 5.6.4 to determine which type of bearing is available in each series or model of transmission. For any series not listed in the chart, contact your local OE Chassis manufacturer or EATON Fuller representative.

EATON FULLER TRANSMISSION INDEX

EATON FULLER Transmission Gear Load Chart												
				RIGHT Side – 6-Bolt				BOTTOM – 8-Bolt				
				45 Teeth Driver Gear				47 Teeth Driver Gear				
				Standard Bearing		HD Bearing		Standard Bearing		HD Bearing		
		PTO RATING		Transmission Application Rating								
PTO Series	Ratio	Intermittent	Continuous	Int	Cont	Int	Cont	Ratio	Int	Cont	Int	Cont
272	A	300	300	300	300	300	300	A	N/A	N/A	N/A	N/A
	B	300	300	300	300	300	300	B	300	300	300	300
272/282	C	300	300	300	300	300	300	C	300	300	300	300
	D	300	300	300	300	300	300	D	293	293	300	300
	G	300	300	257	257	300	300	G	246	246	300	300
	K	300	300	230	230	300	300	K	220	220	300	300
	M	300	300	206	206	300	294	M	197	197	300	281
	P	300	300	184	184	300	263	P	176	176	300	252
	S	300	300	165	165	300	235	S	158	158	300	225
282	T	300	300	N/A	N/A	N/A	N/A	T	141	141	300	201
442/489	A	250	175	250	175	250	175	A	250	175	250	175
	B	250	175	250	175	250	175	B	250	175	250	175
	C	250	175	250	175	250	175	C	250	175	250	175
	F	250	175	250	175	250	175	F	250	175	250	175
	H	250	175	250	175	250	175	H	249	175	250	175
	L	250	175	233	175	250	175	L	223	175	250	175
	Q	225	158	216	158	225	158	Q	207	158	225	158
	R	225	158	187	158	225	158	R	179	158	225	158
	S	200	140	157	140	200	140	S	150	140	200	140
	U	195	137	132	132	195	137	U	126	126	195	137
	W	175	123	112	112	175	123	W	107	107	175	123
X	140	98	95	95	140	98	X	91	91	140	98	
660/680	F	375	263	301	263	375	263	F	289	263	375	263
	H	375	263	260	260	375	263	H	249	249	375	263
	Q	375	263	216	216	375	263	Q	207	207	375	263
	R	350	245	187	187	350	245	R	179	179	350	245
	S	350	245	157	157	336	224	S	150	150	322	215

NOTES:

1. STANDARD BEARING (STD) = 350 lb-ft CONTINUOUS DUTY
2. HEAVY DUTY BEARING (HD) = 750 lb-ft INTERMITTENT, 500 lb-ft CONTINUOUS DUTY
3. RT/RTL/RTO/RTLO Transmissions can come from the factory with either the standard or HD bearing. See chart on page 5.6.4 for guidance.
4. All FR/FRO and FA/FO Transmissions have the HD Bearing factory installed and the HD Bearing chart should be used for these applications.

Gray area denotes the **Transmission Application Rating** is LOWER than the **PTO Rating** alone.

EATON FULLER TRANSMISSION INDEX

EATON FULLER Transmission Gear Load Chart													
						RIGHT Side – 6-Bolt				BOTTOM – 8-Bolt			
						45 Teeth Driver Gear				47 Teeth Driver Gear			
				PTO RATING		Standard Bearing		HD Bearing				Standard Bearing	
				Transmission Application Rating									
PTO Series	Ratio	Intermittent	Continuous	Int	Cont	Int	Cont	Ratio	Int	Cont	Int	Cont	
880	B	500	350	N/A		N/A	N/A	B	424	350	500	350	
	D	500	350					D	357	350	500	350	
	G	500	350					G	329	329	500	350	
	J	500	350					J	280	280	500	350	
	M	500	350					M	238	238	500	340	
	Q	450	315					Q	203	203	435	290	
	R	400	280					R	173	173	370	247	
	T	350	245					T	134	134	287	191	
823	B	750	500	N/A		N/A	N/A	B	424	424	750	500	
	D	750	500					D	357	357	750	500	
	G	750	500					Q	329	329	705	470	
	J	750	500					J	280	280	599	400	
	M	650	450					M	238	238	511	340	
	R	550	400					R	173	173	370	247	
	T	500	350					T	142	142	305	203	
	885	B	500					350	N/A		N/A	N/A	B
G		500	350	G	329	329	500	350					
J		500	350	J	280	280	500	350					
M		500	350	M	238	238	500	340					

NOTES:

- STANDARD BEARING (STD) = 350 lb-ft CONTINUOUS DUTY
- HEAVY DUTY BEARING (HD) = 750 lb-ft INTERMITTENT, 500 lb-ft CONTINUOUS DUTY
- RT/RTL/RTO/RTLO Transmissions can come from the factory with either the standard or HD bearing. See chart on page 5.6.4 for guidance.
- All FR/FRO and FA/FO Transmissions have the HD Bearing factory installed and the HD Bearing chart should be used for these applications.

Gray area denotes the **Transmission Application Rating** is LOWER than the **PTO Rating** alone.

EATON FULLER TRANSMISSION INDEX

Input Shaft Bearing Matrix for Fuller

FOR REFERENCE ONLY

Transmission Model	INPUT SHAFT BEARING	
	Standard Duty 81504	Heavy Duty 4301417
F-14E316B-LSE, 15E316B-LSE, 17E316B-LSE	N/A	
FM-1XD310B-LST		OPTION
FM-14E310B-LAS, FM-15E310B-LAS, 15E316B-LSE	N/A	
FO-14E310C-LAS, 16E310C-LAS	N/A	
FO(M)-16D313E-LEP		OPTION
FOM-15E310C-LAS, 16E310C-LAS	N/A	
FR/FRO-xx210B/C	N/A	
RT-6609A	4301863	N/A
RT-8608L		OPTION
RT-8709B	N/A	
RTX-xx609B		OPTION
RT-xx709H		OPTION
RTOC-16909A (T2)		OPTION
RTOC-18909A (T2)	N/A	
RT/O-xx908LL	N/A	
RTO-xx909ALL	N/A	
RTLO-xx913A		OPTION
RT/O-xx915	N/A	
RTLO-xx918B (except 22918B)		OPTION
RTLO-22918B	N/A	
RTO-xx910B/C-AS/DM		OPTION
RTLO(M)-16913L-DM		OPTION
RTLO-xx918A-AS2 (except 22918A-AS)		OPTION
RTLO-22918A-AS	N/A	
T/TX-14607A/B		OPTION

HD Bearing Part Number - 4301417

NOTE: Eaton recommends the use of a heavy duty input shaft bearing for transmissions that will be equipped with a transmission mounted 6 or 8-Bolt PTO.

Maximum total* PTO output cannot exceed :

750 lb-ft intermittent load when using the heavy duty bearing - 500 lb-ft continuous

350 lb-ft when using the standard duty bearing

*Total = the sum of all PTOs that can be used at the same time.

Transmission Make and Model	PTO Appl. Number	Number Forward Speeds	Teeth in PTO Driver
AT-1202	FLR-60	2	T30-B30
EA-11109LA	FLR-117	9	L39-R39
EDCO-6F107A-P (Procision Series w/ Park Paw)	FLR-114	7	L23-R47
EDCO-6F107A-X (Procision Series)	FLR-114	7	L23-R47
EDCO-9N107A-P (Procision Series w/ Park Paw)	FLR-114	7	L23-R47
EDCO-9N107A-X (Procision Series)	FLR-114	7	L23-R47
EE-17F111B (Endurant)	FLR-116	11	CS-B42
EEO-14F112C (Endurant)	FLR-116	12	CS-B42
EEO-15F112C (Endurant)	FLR-116	12	CS-B42
EEO-16F112C (Endurant)	FLR-116	12	CS-B42
EEO-17F112C (Endurant)	FLR-116	12	CS-B42
EEO-18F112C (Endurant)	FLR-116	12	CS-B42
EH-6E706B-CD (Hybrid Electric System)	FLR-92Hy	6	L48
EH-6E706B-P (Hybrid Electric System)	FLR-92Hy	6	L48
EH-8E306A-CD (Hybrid Electric System)	FLR-92Hy	6	L48
EH-8E306A-UP (Hybrid Electric System)	FLR-92Hy	6	L48
EH-8E306A-UPG (Hybrid Electric System)	FLR-92Hy	6	L48
EH-8E406A-CD (Hybrid Electric System)	FLR-92Hy	6	L48
EH-8E406A-CDR (Hybrid Electric System)	FLR-92Hy	6	L48
EH-8E406A-P (Hybrid Electric System)	FLR-92Hy	6	L48
EH-8E406A-T (Hybrid Electric System)	FLR-92Hy	6	L48
EH-8E406A-UP (Hybrid Electric System)	FLR-92Hy	6	L48
EH-8E406A-UPG (Hybrid Electric System)	FLR-92Hy	6	L48
EHD-14F112C-N (Endurant CNG)	FLR-116	12	CS-B42
ES-11109 (Left Side Forward Opening)	FLR-84LF	9	LF32-CS
ESO-4106A	FLR-118	6	L22
ESO-4206A	FLR-118	6	L22
ESO-6106	FLR-115	6	L33-R33
EXD-16F118D	FLR-119	18	CS-B46
EXD-18F118D	FLR-119	18	CS-B46
EXDP-16F118D	FLR-119	18	CS-B46
EXDP-18F118D	FLR-119	18	CS-B46
EXDP-20F118D	FLR-119	18	CS-B46
F-14E16B-LSE (UltraShift Plus)	FLR-107	16	CS-R45-B47
F-15E16B-LSE (UltraShift Plus)	FLR-107	16	CS-R45-B47
F-17E16B-LSE (UltraShift Plus)	FLR-107	16	CS-R45-B47
F-5405B-DM3 (UltraShift HV)	FLR-92	5	L48-R48
F-5405-DM3	FLR-97	5	L39-R39
F-6405B-DM3 (UltraShift HV)	FLR-92	5	L48-R48
F-6406N-ASW	FLR-97	6	L39-R39
F-6406N-ASX	FLR-97	6	L39-R39



IMPORTANT: See Safety Information in Section 1 of the Chelsea Applications catalog HY25-3000/US

Transmission PTO Driver & Apertures (Viewed from Rear of Transmission)
L-Left Side R-Right Side B-Bottom Side T-Top Side CS-Countershaft
For transmissions not listed, contact your authorized Chelsea Distributor.

EATON FULLER TRANSMISSION INDEX

Transmission Make and Model	PTO Appl. Number	Number Forward Speeds	Teeth in PTO Driver
F-6406N-AW3	FLR-97	6	L39-R39
F-8406N-ASW	FLR-97	6	L39-R39
FA-11810B (Advantage Series) ThruShaft use AV	FLR-105	10	R45-B47
FA-12810B (Advantage Series) ThruShaft use AV mounting	FLR-105	10	R45-B47
FA-13810B (Advantage Series) ThruShaft use AV mounting	FLR-105	10	R45-B47
FA-14810B (Advantage Series) ThruShaft use AV mounting	FLR-105	10	R45-B47
FA-15810B (Advantage Series) ThruShaft use AV mounting	FLR-105	10	R45-B47
FA-9810B (Advantage Series) ThruShaft use AV mounting	FLR-105	10	R45-B47
FAF-11810B (Advantage Series) ThruShaft use AV	FLR-105	10	R45-B47
FAF-12810B (Advantage Series) ThruShaft use AV mounting	FLR-105	10	R45-B47
FAF-13810B (Advantage Series) ThruShaft use AV mounting	FLR-105	10	R45-B47
FAF-14810B (Advantage Series) ThruShaft use AV mounting	FLR-105	10	R45-B47
FAF-15810B (Advantage Series) ThruShaft use AV mounting	FLR-105	10	R45-B47
FAF-9810B (Advantage Series) ThruShaft use AV mounting	FLR-105	10	R45-B47
FAM-14810B (Advantage Series) ThruShaft use AV mounting	FLR-105	10	R45-B47
FAM-14810B-EA3 (Advantage Series Automated) ThruShaft use AV mounting	FLR-105	10	R45-B47
FAM-15810B (Advantage Series) ThruShaft use AV mounting	FLR-105	10	R45-B47
FAM-15810B-EA3 (Advantage Series Automated) ThruShaft use AV mounting	FLR-105	10	R45-B47
FAMF-14810B (Advantage Series) ThruShaft use AV mounting	FLR-105	10	R45-B47
FAMF-15810B (Advantage Series) ThruShaft use AV mounting	FLR-105	10	R45-B47
FAO-11810C (Advantage Series) ThruShaft use AV mounting	FLR-112	10	R45-B47
FAO-12810C (Advantage Series) ThruShaft use AV mounting	FLR-112	10	R45-B47
FAO-13810C (Advantage Series) ThruShaft use AV mounting	FLR-112	10	R45-B47
FAO-14810C (Advantage Series) ThruShaft use AV mounting	FLR-112	10	R45-B47
FAO-14810C-EA3 (Advantage Series Automated) ThruShaft use AV mounting	FLR-112	10	R45-B47
FAO-15810C (Advantage Series) ThruShaft use AV mounting	FLR-112	10	R45-B47
FAO-16810C (Advantage Series) ThruShaft use AV mounting	FLR-112	10	R45-B47
FAO-16810C-EA3 (Advantage Series Automated) ThruShaft use AV mounting	FLR-112	10	R45-B47
FAO-16810S-EN3 (Advantage Series Automated) ThruShaft use AV mounting	FLR-112	10	R45-B47
FAO-16810S-EP3 (Advantage Series Automated) ThruShaft use AV mounting	FLR-112	10	R45-B47
FAOF-11810C (Advantage Series) ThruShaft use AV mounting	FLR-112	10	R45-B47
FAOF-12810C (Advantage Series) ThruShaft use AV mounting	FLR-112	10	R45-B47
FAOF-13810C (Advantage Series) ThruShaft use AV mounting	FLR-112	10	R45-B47
FAOF-14810C (Advantage Series) ThruShaft use AV mounting	FLR-112	10	R45-B47
FAOF-15810C (Advantage Series) ThruShaft use AV mounting	FLR-112	10	R45-B47
FAOF-16810C (Advantage Series) ThruShaft use AV mounting	FLR-112	10	R45-B47



IMPORTANT: See Safety Information
in Section 1 of the Chelsea Applications
catalog HY25-3000/US

Transmission PTO Driver & Apertures (Viewed from Rear of Transmission)
L-Left Side R-Right Side B-Bottom Side T-Top Side CS-Countershaft
For transmissions not listed, contact your authorized Chelsea Distributor.

Transmission Make and Model	PTO Appl. Number	Number Forward Speeds	Teeth in PTO Driver
FAOM-14810C (Advantage Series) ThruShaft use AV mounting	FLR-112	10	R45-B47
FAOM-14810S-EC3 (Advantage Series Automated) ThruShaft use AV mounting	FLR-112	10	R45-B47
FAOM-15810C (Advantage Series) ThruShaft use AV mounting	FLR-112	10	R45-B47
FAOM-15810C-EA3 (Advantage Series Automated) ThruShaft use AV mounting	FLR-112	10	R45-B47
FAOM-15810S-EC3 (Advantage Series Automated) ThruShaft use AV mounting	FLR-112	10	R45-B47
FAOM-15810S-EN3 (Advantage Series Automated) ThruShaft use AV mounting	FLR-112	10	R45-B47
FAOM-15810S-EP3 (Advantage Series Automated) ThruShaft use AV mounting	FLR-112	10	R45-B47
FAOM-16810C (Advantage Series) ThruShaft use AV mounting	FLR-112	10	R45-B47
FAOM-16810C-EA3 (Advantage Series Automated) ThruShaft use AV mounting	FLR-112	10	R45-B47
FAOMF-14810C (Advantage Series) ThruShaft use AV mounting	FLR-112	10	R45-B47
FAOMF-15810C (Advantage Series) ThruShaft use AV mounting	FLR-112	10	R45-B47
FAOMF-16810C (Advantage Series) ThruShaft use AV mounting	FLR-112	10	R45-B47
FM-14E310B-LAS (UltraShift Plus) Thrushaft use AT mounting	FLR-111	10	R45-B47
FM-15E16B-LSE (UltraShift Plus)	FLR-107	16	CS-R45-B47
FM-15E310B-LAS (UltraShift Plus) Thrushaft use AT mounting	FLR-111	10	R45-B47
FO-10E308LL-VCS (UltraShift Plus) Thrushaft use BD mounting	FLR-106	8+2	CS-R45-B47
FO-10E309ALL-VMS (UltraShift Plus) Thrushaft use BD mounting	FLR-107	9+2	CS-R45-B47
FO-10E310C-VAS (UltraShift Plus)Thrushaft use AT mounting	FLR-107	10	CS-R45-B47
FO-11E308LL-VCS (UltraShift Plus) Thrushaft use BD mounting	FLR-106	8	CS-R45-B47
FO-11E309ALL-VMS (UltraShift Plus) Thrushaft use BD mounting	FLR-107	9+2	CS-R45-B47
FO-12E308LL-VCS (UltraShift Plus) Thrushaft use BD mounting	FLR-106	8+2	CS-R45-B47
FO-12E309ALL-VMS (UltraShift Plus) Thrushaft use BD mounting	FLR-107	9+2	CS-R45-B47
FO-12E310C-VAS (UltraShift Plus)Thrushaft use AT mounting	FLR-107	10	CS-R45-B47
FO-14E308LL-VCS (UltraShift Plus) Thrushaft use BD mounting	FLR-106	8+2	CS-R45-B47
FO-14E309ALL-VMS (UltraShift Plus)Thrushaft use BD mounting	FLR-107	9+2	CS-R45-B47
FO-14E310C-LAS (UltraShift Plus) Thrushaft use AT mounting	FLR-107	10	CS-R45-B47
FO-14E310C-VAS (UltraShift Plus)Thrushaft use AT mounting	FLR-107	10	CS-R45-B47
FO-14E313A-MHP (UltraShift Plus)	FLR-107	13	CS-R45-B47
FO-14E313A-VHP (UltraShift Plus)	FLR-107	13	CS-R45-B47
FO-14E318B-MXP (UltraShift Plus)	FLR-107	18	CS-R45-B47
FO-14E318B-VXP (UltraShift Plus)	FLR-107	18	CS-R45-B47
FO-16D313E-LEP (UltraShift)	FLR-113	13	R45
FO-16E308LL-VCS (UltraShift Plus) Thrushaft use BD mounting	FLR-106	8+2	CS-R45-B47
FO-16E309ALL-VMS (UltraShift Plus)Thrushaft use BD mounting	FLR-107	9+2	CS-R45-B47
FO-16E310C-LAS (UltraShift Plus) Thrushaft use AT mounting	FLR-107	10	CS-R45-B47
FO-16E310C-VAS (UltraShift Plus) Thrushaft use AT mounting	FLR-107	10	CS-R45-B47

Eaton Fuller



IMPORTANT: See Safety Information in Section 1 of the Chelsea Applications catalog HY25-3000/US

Transmission PTO Driver & Apertures (Viewed from Rear of Transmission)
L-Left Side R-Right Side B-Bottom Side T-Top Side CS-Countershaft
For transmissions not listed, contact your authorized Chelsea Distributor.

EATON FULLER TRANSMISSION INDEX

Transmission Make and Model	PTO Appl. Number	Number Forward Speeds	Teeth in PTO Driver
FO-16E313A-MHP (UltraShift Plus)	FLR-107	13	CS-R45-B47
FO-16E313A-VHP (UltraShift Plus)	FLR-107	13	CS-R45-B47
FO-16E318B-MXP (UltraShift Plus)	FLR-107	18	CS-R45-B47
FO-16E318B-VXP (UltraShift Plus)	FLR-107	18	CS-R45-B47
FO-17E308LL-VCS (UltraShift Plus) Thrushaft use BD Mounting	FLR-106	8+2	CS-R45-B47
FO-17E309ALL-VMS (UltraShift Plus) Thrushaft use BD mounting	FLR-107	9+2	CS-R45-B47
FO-18E310C-LAS (UltraShift Plus) Thrushaft use AT mounting	FLR-107	10	CS-R45-B47
FO-18E313A-MHP (UltraShift Plus)	FLR-107	13	CS-R45-B47
FO-18E313A-VHP (UltraShift Plus)	FLR-107	13	CS-R45-B47
FO-18E318B-MXP (UltraShift Plus)	FLR-107	18	CS-R45-B47
FO-18E318B-VXP (UltraShift Plus)	FLR-107	18	CS-R45-B47
FO-20E313A-MHP (UltraShift Plus)	FLR-107	13	CS-R45-B47
FO-20E313A-VHP (UltraShift Plus)	FLR-107	13	CS-R45-B47
FO-20E318B-MXP (UltraShift Plus)	FLR-107	18	CS-R45-B47
FO-20E318B-VXP (UltraShift Plus)	FLR-107	18	CS-R45-B47
FO-22E318B-MXP (UltraShift Plus)	FLR-107	18	CS-R45-B47
FO-22E318B-VXP (UltraShift Plus)	FLR-107	18	CS-R45-B47
FO-5406B-DM3 (UltraShift HV)	FLR-92	6	L48-R48
FO-6406A-ASW	FLR-92	6	L48-R48
FO-6406A-ASX	FLR-92	6	L48-R48
FO-6406A-AW3	FLR-92	6	L48-R48
FO-6406B-DM3 (UltraShift HV)	FLR-92	6	L48-R48
FO-6406N-AW3	FLR-97	6	L39-R39
FO-8406A-ASW	FLR-92	6	L48-R48
FO-8406A-ASX	FLR-92	6	L48-R48
FO-8406A-AW3	FLR-92	6	L48-R48
FOM-14E310C-LAS (UltraShift Plus) Thrushaft use AT mounting	FLR-107	10	CS-R45-B47
FOM-14E310C-VAS (UltraShift Plus)Thrushaft use AT mounting	FLR-107	10	CS-R45-B47
FOM-15E310C-LAS (UltraShift Plus) Thrushaft use AT mounting	FLR-107	10	CS-R45-B47
FOM-15E310C-VAS (UltraShift Plus)Thrushaft use AT mounting	FLR-107	10	CS-R45-B47
FOM-16D313E-LEP	FLR-58	13	CS-R45-B47
FOM-16D313E-LEP (UltraShift)	FLR-113	13	R45
FOM-16E310C-LAS (UltraShift Plus) Thrushaft use AT mounting	FLR-107	10	CS-R45-B47
FOM-16E310C-VAS (UltraShift Plus)Thrushaft use AT mounting	FLR-107	10	CS-R45-B47
FR-11210B	FLR-90	10	CS-R45-B47
FR-12210B	FLR-90	10	CS-R45-B47



IMPORTANT: See Safety Information
in Section 1 of the Chelsea Applications
catalog HY25-3000/US

Transmission PTO Driver & Apertures (Viewed from Rear of Transmission)
L-Left Side R-Right Side B-Bottom Side T-Top Side CS-Countershaft
For transmissions not listed, contact your authorized Chelsea Distributor.

EATON FULLER TRANSMISSION INDEX

Transmission Make and Model	PTO Appl. Number	Number Forward Speeds	Teeth in PTO Driver
FR-13210B	FLR-90	10	CS-R45-B47
FR-14210B	FLR-90	10	CS-R45-B47
FR-15210B	FLR-90	10	CS-R45-B47
FR-9210	FLR-90	10	CS-R45-B47
FR-9210B	FLR-90	10	CS-R45-B47
FRF-9210B	FLR-90	10	CS-R45-B47
FRLO-14410C	FLR-95	10	L51-R51
FRLO-14410C-T2	FLR-95	10	L51-R51
FRLO-15410C	FLR-95	10	L51-R51
FRLO-15410C-T2	FLR-95	10	L51-R51
FRLO-16410C	FLR-95	10	L51-R51
FRLO-16410C-T2	FLR-95	10	L51-R51
FRM-15210B (Thrushaft use BJ mounting)	FLR-90	10	CS-R45-B47
FRO-11210B	FLR-91	10	CS-R45-B47
FRO-11210C	FLR-88	10	CS-R45-B47
FRO-12210B	FLR-91	10	CS-R45-B47
FRO-12210C	FLR-88	10	CS-R45-B47
FRO-13210B	FLR-91	10	CS-R45-B47
FRO-13210C	FLR-88	10	CS-R45-B47
FRO-14210B	FLR-91	10	CS-R45-B47
FRO-14210C	FLR-88	10	CS-R45-B47
FRO-15210B	FLR-91	10	CS-R45-B47
FRO-15210C	FLR-88	10	CS-R45-B47
FRO-16210B	FLR-91	10	CS-R45-B47
FRO-16210C	FLR-88	10	CS-R45-B47
FRO-16210R	FLR-88	10	CS-R45-B47
FRO-17210C	FLR-88	10	CS-R45-B47
FRO-18210C	FLR-88	10	CS-R45-B47
FROF-15210C	FLR-88	10	CS-R45-B47
FRW-15210B	FLR-90	10	CS-R45-B47
FS-4205A	FLR-78	5	L28-R28
FS-4205B	FLR-79	5	L28-R28
FS-5306A	FLR-68	6	L38-CS-R38
FS-5406A	FLR-68	6	L38-CS-R38
FS-5406N	FLR-97	6	L39-R39
FS-6106A	FLR-67	6	L50-R50



IMPORTANT: See Safety Information in Section 1 of the Chelsea Applications catalog HY25-3000/US

Transmission PTO Driver & Apertures (Viewed from Rear of Transmission)
L-Left Side R-Right Side B-Bottom Side T-Top Side CS-Countershaft
For transmissions not listed, contact your authorized Chelsea Distributor.

EATON FULLER TRANSMISSION INDEX

Transmission Make and Model	PTO Appl. Number	Number Forward Speeds	Teeth in PTO Driver
FS-6109A (Left Side Forward Opening)	FLR-84LF	9	LF32-CS
FS-6205A	FLR-69	5	L39-R39
FS-6205B	FLR-70	5	L41-R41
FS-6206	FLR-68	6	L38-CS-R38
FS-6206A	FLR-68	6	L38-CS-R38
FS-6209A (Left Side Forward Opening)	FLR-84LF	9	LF32-CS
FS-6305A	FLR-69	5	L39-R39
FS-6305B	FLR-70	5	L41-R41
FS-6306	FLR-68	6	L38-CS-R38
FS-6306A	FLR-68	6	L38-CS-R38
FS-6309A (Left Side Forward Opening)	FLR-84LF	9	LF32-CS
FS-6406	FLR-68	6	L38-CS-R38
FS-6406A	FLR-68	6	L38-CS-R38
FS-6406N	FLR-97	6	L39-R39
FS-7206A	FLR-67	6	L50-R50
FS-8206A	FLR-67	6	L50-R50
FS-8209A (ES11109)(Left Side Forward Opening)	FLR-84LF	9	LF32-CS
FS-8309 (Left Side Forward Opening)	FLR-84LF	9	LF32-CS
FS-8406A	FLR-67	6	L50-R50
FSB-5406B	FLR-94	6	L38-R38
FSB-6206A	FLR-94	6	L38-R38
FSB-6406B	FLR-94	6	L38-R38
FSO-5206 (B)	FLR-87	6	L47-CS
FSO-5406A	FLR-92	6	L48-R48
FSO-6109A (Left Forward)	FLR-96LF	9	LF43
FSO-6406A (Eaton Brazil)	FLR-92	6	L48-R48
FSO-8209A (Left Side Forward Opening)	FLR-96LF	9	LF43
FSO-8406A (Eaton Brazil)	FLR-92	6	L48-R48
RT-11609A (Thrushaft option use AT mounting)	FLR-34	8+1	CS-R45-B47
RT-11709H (Thrushaft option use AU mounting)	FLR-34	9	CS-R45-B47
RT-12609A (Thrushaft option use AT mounting)	FLR-34	9	CS-R45-B47
RT-12709A	FLR-34	9	CS-R45-B47
RT-12710B (Thrushaft option use AU mounting)	FLR-34	10	CS-R45-B47
RT-13609A (Thrushaft option use AT mounting)	FLR-34	9	CS-R45-B47
RT-13709H (Thrushaft option use AU mounting)	FLR-34	9	CS-R45-B47
RT-13710B (Thrushaft option use AU mounting)	FLR-34	10	CS-R45-B47



IMPORTANT: See Safety Information
in Section 1 of the Chelsea Applications
catalog HY25-3000/US

Transmission PTO Driver & Apertures (Viewed from Rear of Transmission)
L-Left Side R-Right Side B-Bottom Side T-Top Side CS-Countershaft
For transmissions not listed, contact your authorized Chelsea Distributor.

EATON FULLER TRANSMISSION INDEX

Transmission Make and Model	PTO Appl. Number	Number Forward Speeds	Teeth in PTO Driver
RT-14609A (Thrushaft option use AU mounting)	FLR-34	8+1	CS-R45-B47
RT-14709A	FLR-34	9	CS-R45-B47
RT-14710B (Thrushaft option use AU mounting)	FLR-34	10	CS-R45-B47
RT-14710B-AS2	FLR-34	10	CS-R45-B47
RT-14715 (Thrushaft option use BD mounting)	FLR-34	15	CS-R45-B47
RT-14910B-AS2	FLR-34	10	CS-R45-B47
RT-14915	FLR-34	15	CS-R45-B47
RT-15715	FLR-34	15	CS-R45-B47
RT-613	FLR-40	13	R33-B33
RT-6609A	FLR-66	9	R33-B33
RT-6610	FLR-40	10	R33-B33
RT-6613	FLR-40	13	R33-B33
RT-7608LL	FLR-66	8+2	R33-B33
RT-8608L	FLR-64	8	R45-B47
RT-8609	FLR-66	9	R33-B33
RT-8709B	FLR-34	9	CS-R45-B47
RT-8908LL	FLR-34	8+2	CS-R45-B47
RT-9710B (Thrushaft option use AU mounting)	FLR-34	10	CS-R45-B47
RTA-14710B-AS	FLR-34	10	CS-R45-B47
RTAO-10710B-AC	FLR-57	10	CS-R45-B47
RTAO-10710B-AS	FLR-57	10	CS-R45-B47
RTAO-10710C-AC	FLR-58	10	CS-R45-B47
RTAO-10710C-AS	FLR-58	10	CS-R45-B47
RTAO-12710B-AC	FLR-57	10	CS-R45-B47
RTAO-12710B-AS	FLR-57	10	CS-R45-B47
RTAO-12710C-AC	FLR-58	10	CS-R45-B47
RTAO-12710C-AS	FLR-58	10	CS-R45-B47
RTAO-14710B-AC	FLR-57	10	CS-R45-B47
RTAO-14710B-AS	FLR-57	10	CS-R45-B47
RTAO-14710C-AC	FLR-58	10	CS-R45-B47
RTAO-14710C-AS	FLR-58	10	CS-R45-B47
RTAO-16710B-AC	FLR-57	10	CS-R45-B47
RTAO-16710B-AS	FLR-57	10	CS-R45-B47
RTAO-16710C-AS	FLR-58	10	CS-R45-B47
RTF-11609A	FLR-34	9	CS-R45-B47
RTF-12609A	FLR-34	9	CS-R45-B47



IMPORTANT: See Safety Information in Section 1 of the Chelsea Applications catalog HY25-3000/US

Transmission PTO Driver & Apertures (Viewed from Rear of Transmission)
L-Left Side R-Right Side B-Bottom Side T-Top Side CS-Countershaft
For transmissions not listed, contact your authorized Chelsea Distributor.

EATON FULLER TRANSMISSION INDEX

Transmission Make and Model	PTO Appl. Number	Number Forward Speeds	Teeth in PTO Driver
RTF-12709H	FLR-34	9	CS-R45-B47
RTF-12710B	FLR-34	10	CS-R45-B47
RTF-13609A	FLR-34	9	CS-R45-B47
RTF-13709H	FLR-34	9	CS-R45-B47
RTF-13710B	FLR-34	10	CS-R45-B47
RTF-14609A	FLR-34	9	CS-R45-B47
RTF-14709H	FLR-34	9	CS-R45-B47
RTF-14710B	FLR-34	10	CS-R45-B47
RTF-14715	FLR-34	15	CS-R45-B47
RTF-14915	FLR-34	15	CS-R45-B47
RTF-15715	FLR-34	15	CS-R45-B47
RTL-13710B	FLR-34	10	CS-R45-B47
RTL-14710B	FLR-34	10	CS-R45-B47
RTL-16609E (Convertible 9 to 13 Speed)	FLR-58	9	CS-R45-B47
RTLO-11610B-T2	FLR-34	10	CS-R45-B47
RTLO-12610B	FLR-34	10	CS-R45-B47
RTLO-12610B-T2	FLR-34	10	CS-R45-B47
RTLO-12713A	FLR-58	13	CS-R45-B47
RTLO-13118-AMT	FLR-58	13	CS-R45-B47
RTLO-13610B	FLR-34	10	CS-R45-B47
RTLO-13610B-T2	FLR-34	10	CS-R45-B47
RTLO-14610A	FLR-34	10	CS-R45-B47
RTLO-14610B	FLR-34	10	CS-R45-B47
RTLO-14610B-T2	FLR-34	10	CS-R45-B47
RTLO-14613B	FLR-34	13	CS-R45-B47
RTLO-14713A	FLR-58	13	CS-R45-B47
RTLO-14713A-T2	FLR-58	13	CS-R45-B47
RTLO-14718B	FLR-58	18	CS-R45-B47
RTLO-14718B-T2	FLR-58	18	CS-R45-B47
RTLO-14918A-AS2	FLR-58	18	CS-R45-B47
RTLO-14918A-AS3	FLR-58	18	CS-R45-B47
RTLO-14918B	FLR-58	18	CS-R45-B47
RTLO-14918B-AS	FLR-58	18	CS-R45-B47
RTLO-15610B-T2	FLR-34	10	CS-R45-B47
RTLO-16610B	FLR-34	10	CS-R45-B47
RTLO-16610B-T2	FLR-34	10	CS-R45-B47



IMPORTANT: See Safety Information
in Section 1 of the Chelsea Applications
catalog HY25-3000/US

Transmission PTO Driver & Apertures (Viewed from Rear of Transmission)
L-Left Side R-Right Side B-Bottom Side T-Top Side CS-Countershaft
For transmissions not listed, contact your authorized Chelsea Distributor.

EATON FULLER TRANSMISSION INDEX

Transmission Make and Model	PTO Appl. Number	Number Forward Speeds	Teeth in PTO Driver
RTLO-16713A	FLR-58	13	CS-R45-B47
RTLO-16713A-T2	FLR-58	13	CS-R45-B47
RTLO-16718B	FLR-58	18	CS-R45-B47
RTLO-16718B-T2	FLR-58	18	CS-R45-B47
RTLO-16913A	FLR-58	13	CS-R45-B47
RTLO-16913L-DM3 (UltraShift)	FLR-113	13	R45
RTLO-16913L-LHP	FLR-58	13	CS-R45-B47
RTLO-16918A-AS2	FLR-58	18	CS-R45-B47
RTLO-16918A-AS3	FLR-58	18	CS-R45-B47
RTLO-16918B	FLR-58	18	CS-R45-B47
RTLO-16918B-AS	FLR-58	18	CS-R45-B47
RTLO-17610B	FLR-34	10	CS-R45-B47
RTLO-17610B-T2	FLR-34	10	CS-R45-B47
RTLO-18610B	FLR-34	10	CS-R45-B47
RTLO-18718B	FLR-58	18	CS-R45-B47
RTLO-18718B-T2	FLR-58	18	CS-R45-B47
RTLO-18913A	FLR-58	13	CS-R45-B47
RTLO-18913A-T2	FLR-58	13	CS-R45-B47
RTLO-18918A-AS2	FLR-58	18	CS-R45-B47
RTLO-18918B	FLR-58	18	CS-R45-B47
RTLO-18918B-AS	FLR-58	18	CS-R45-B47
RTLO-20913A	FLR-58	13	CS-R45-B47
RTLO-20918A-AS2	FLR-58	18	CS-R45-B47
RTLO-20918B	FLR-58	18	CS-R45-B47
RTLO-20918B-AS	FLR-58	18	CS-R45-B47
RTLO-22918A-AS2	FLR-58	18	CS-R45-B47
RTLO-22918A-AS3	FLR-58	18	CS-R45-B47
RTLO-22918B	FLR-58	18	CS-R45-B47
RTLOM-16913L-DM3 (UltraShift)	FLR-113	13	R45
RTLOM-16913L-LHP	FLR-58	13	CS-R45-B47
RTO-10710B-AS2	FLR-57	10	CS-R45-B47
RTO-10910B-AS2	FLR-57	10	CS-R45-B47
RTO-10910B-AS3	FLR-57	10	CS-R45-B47
RTO-10910B-DM2 (UltraShift)	FLR-100	10	CS-R45-B47
RTO-10910B-DM3 (UltraShift)	FLR-100	10	CS-R45-B47
RTO-11709MLL	FLR-58	9+2	CS-R45-B47



IMPORTANT: See Safety Information in Section 1 of the Chelsea Applications catalog HY25-3000/US

Transmission PTO Driver & Apertures (Viewed from Rear of Transmission)
L-Left Side R-Right Side B-Bottom Side T-Top Side CS-Countershaft
For transmissions not listed, contact your authorized Chelsea Distributor.

EATON FULLER TRANSMISSION INDEX

Transmission Make and Model	PTO Appl. Number	Number Forward Speeds	Teeth in PTO Driver
RTO-11908LL	FLR-57	8+2	CS-R45-B47
RTO-11909ALL	FLR-58	11	CS-R45-B47
RTO-11909MLL	FLR-58	9	CS-R45-B47
RTO-12710B-AS2	FLR-57	10	CS-R45-B47
RTO-12910B-AS2 (Thrushaft option use AT mounting)	FLR-57	10	CS-R45-B47
RTO-12910B-AS3 (Thrushaft option use AT mounting)	FLR-57	10	CS-R45-B47
RTO-12910B-DM2 (UltraShift)	FLR-100	10	CS-R45-B47
RTO-12910B-DM3 (UltraShift)	FLR-100	10	CS-R45-B47
RTO-14609B (Thrushaft option use AU mounting)	FLR-58	9	CS-R45-B47
RTO-14613	FLR-34	13	CS-R45-B47
RTO-14709MLL	FLR-58	9+2	CS-R45-B47
RTO-14710B-AS2	FLR-57	10	CS-R45-B47
RTO-14908LL	FLR-57	8+2	CS-R45-B47
RTO-14909ALL	FLR-58	11	CS-R45-B47
RTO-14910B-AS2	FLR-57	10	CS-R45-B47
RTO-14910B-AS3	FLR-57	10	CS-R45-B47
RTO-14910B-DM2 (UltraShift)	FLR-100	10	CS-R45-B47
RTO-14910B-DM3 (UltraShift)	FLR-100	10	CS-R45-B47
RTO-14910C-AS2	FLR-58	10	CS-R45-B47
RTO-14910C-AS3	FLR-58	10	CS-R45-B47
RTO-14915	FLR-59	15	CS-R45-B47
RTO-16710B	FLR-57	10	CS-R45-B47
RTO-16710B-AS2	FLR-57	10	CS-R45-B47
RTO-16710C-AS2	FLR-58	10	CS-R45-B47
RTO-16908LL (Thrushaft use BD mounting)	FLR-57	8+2	CS-R45-B47
RTO-16909ALL (Thrushaft use BD mounting)	FLR-58	11	CS-R45-B47
RTO-16910B-AS2	FLR-57	10	CS-R45-B47
RTO-16910B-AS3	FLR-57	10	CS-R45-B47
RTO-16910B-DM2 (UltraShift)	FLR-100	10	CS-R45-B47
RTO-16910B-DM3 (UltraShift)	FLR-100	10	CS-R45-B47
RTO-16910C-AS2	FLR-58	10	CS-R45-B47
RTO-16910C-AS3	FLR-58	10	CS-R45-B47
RTO-16915	FLR-59	15	CS-R45-B47
RTO-18910B-AS2	FLR-58	10	CS-R45-B47
RTO-18910B-AS3	FLR-58	10	CS-R45-B47
RTO-6610	FLR-41	10	R33-B33



IMPORTANT: See Safety Information
in Section 1 of the Chelsea Applications
catalog HY25-3000/US

Transmission PTO Driver & Apertures (Viewed from Rear of Transmission)
L-Left Side R-Right Side B-Bottom Side T-Top Side CS-Countershaft
For transmissions not listed, contact your authorized Chelsea Distributor.

EATON FULLER TRANSMISSION INDEX

Transmission Make and Model	PTO Appl. Number	Number Forward Speeds	Teeth in PTO Driver
RTO-6613	FLR-41	13	R33-B33
RTO-7613	FLR-40	13	R33-B33
RTO-909B	FLR-58	8+1	CS-R45-B47
RTO-9513	FLR-34	13	CS-R45-B47
RTOC-16909A (Convertible 9 to 13 Speed)	FLR-58	9	CS-R45-B47
RTOC-18909A	FLR-58	9	CS-R45-B47
RTOCM-16909A (Convertible 9 to 13 Speed)	FLR-58	13	CS-R45-B47
RTOM-16910B-DM3 (UltraShift)	FLR-100	10	CS-R45-B47
RTX-11609B	FLR-58	9	CS-R45-B47
RTX-11609P	FLR-57	9	CS-R45-B47
RTX-11609R (Thrushaft option use AT mounting)	FLR-57	8+1	CS-R45-B47
RTX-12609B (Thrushaft option use AT mounting)	FLR-58	9	CS-R45-B47
RTX-12609P	FLR-57	9	CS-R45-B47
RTX-12609R	FLR-57	9	CS-R45-B47
RTX-12709H	FLR-58	9	CS-R45-B47
RTX-12710C (Thrushaft option use AU mounting)	FLR-58	10	CS-R45-B47
RTX-13609B	FLR-58	9	CS-R45-B47
RTX-13609B (Thrushaft option use AT mounting)	FLR-58	9	CS-R45-B47
RTX-13709H	FLR-58	9	CS-R45-B47
RTX-13710B	FLR-57	10	CS-R45-B47
RTX-13710C (Thrushaft option use AU mounting)	FLR-58	10	CS-R45-B47
RTX-14609B	FLR-58	9	CS-R45-B47
RTX-14609R (Thrushaft option use AU mounting)	FLR-57	8+1	CS-R45-B47
RTX-14708LL	FLR-57	8	CS-R45-B47
RTX-14709H	FLR-58	9	CS-R45-B47
RTX-14710B (Thrushaft option use AU mounting)	FLR-57	10	CS-R45-B47
RTX-14710C (Thrushaft option use AU mounting)	FLR-58	10	CS-R45-B47
RTX-14715	FLR-59	15	CS-R45-B47
RTX-15715	FLR-59	15	CS-R45-B47
RTX-16709B	FLR-58	9	CS-R45-B47
RTX-16709H	FLR-58	9	CS-R45-B47
RTX-16710B	FLR-57	10	CS-R45-B47
RTX-16710X	FLR-58	10	CS-R45-B47
T-14607A	FLR-75	7	L78-R78
T-14607B	FLR-75	7	L78-R78
TX-14607B	FLR-77	7	L78-R78



IMPORTANT: See Safety Information in Section 1 of the Chelsea Applications catalog HY25-3000/US

Transmission PTO Driver & Apertures (Viewed from Rear of Transmission)
L-Left Side R-Right Side B-Bottom Side T-Top Side CS-Countershaft
For transmissions not listed, contact your authorized Chelsea Distributor.

FLR-34

EATON FULLER



RT-11609A (Thrustaft option use "AT" mounting)	RT-14609A (Thrustaft option use "AU" mounting)	RT-8709B
RT-11709H (Thrustaft option use "AU" mounting)	RT-14709A	RT-8908LL
RT-12609A (Thrustaft option use "AT" mounting)	RT-14710B (Thrustaft option use "AU" mounting)	RT-9710B (Thrustaft option use "AU" mounting)
RT-12709A	RT-14710B-AS2	RTA-14710B-AS
RT-12710B (Thrustaft option use "AU" mounting)	RT-14715 (Thrustaft option use "BD" mounting)	RTF-11609A
RT-13609A (Thrustaft option use "AT" mounting)	RT-14910B-AS2	RTF-12609A
RT-13709H (Thrustaft option use "AU" mounting)	RT-14915	RTF-12709H
RT-13710B (Thrustaft option use "AU" mounting)	RT-15715	RTF-12710B

BOTTOM SIDE ONLY	RIGHT SIDE ONLY
TRANSMISSION GEAR DATA: BOT 08-BOLT Opening Gear FORWARD of Centerline 47 Teeth - SPUR PITCH LINE TO APERTURE FACE: 0.8050" (20.4500MM)	TRANSMISSION GEAR DATA: R.S. 06-BOLT Opening Gear FORWARD of Centerline 45 Teeth - SPUR PITCH LINE TO APERTURE FACE: 1.0850" (27.5600MM)

CAUTION: Application Approval Required for PTO Output Shaft Speeds Above 2500 RPM

PTO Model	Torq I / C †	Dir Rot	Engine %		Filler Block	Adapter Assy	Stud Kit	PTO Model	Torq I / C †	Dir Rot	Engine %		Filler Block	Adapter Assy	Stud Kit
			Fwd	Rev							Fwd	Rev			

ONE SPEED - TWO GEAR - MECHANICAL SHIFT

221ZCAHX-*3	250 I	Opp	61		7-A-032(P)(46)	328564X	Furnished	221XCAHX-*3	250 I	Opp	58		7-A-032(46)		Furnished
221ZEAHX-*3	250 I	Opp	70			328564X	Furnished	221XEAHX-*3	250 I	Opp	67				Furnished
489XAAHX-*5 (12)	250 I	Opp	54				Furnished	442XAAHX-*3 (12)	250 I	Opp	51				Furnished
489XCAHX-*5 (13)	250 I	Opp	69				Furnished	442XBAHX-*3 (18)	250 I	Eng	51		REQUIRED		Furnished
489XFAHX-*5 (2)	250 I	Opp	85				Furnished	442XCAHX-*3 (13)	250 I	Opp	66				Furnished
489XHAHX-*5 (15)	250 I	Opp	99				Furnished	442XFAHX-*3 (2)	250 I	Opp	81				Furnished
489XLAHX-*5 (1)	222 I	Opp	110				Furnished	442XHAHX-*3 (15)	250 I	Opp	94				Furnished
489XQAHX-*5 (1)	206 I	Opp	118				Furnished	442XLAHX-*3 (1)	233 I	Opp	105				Furnished
489XRAHX-*5 (1)	178 I	Opp	137				Furnished	442XQAHX-*3 (1)	216 I	Opp	113				Furnished
489XSAHX-*5 (1)	150 I	Opp	163				Furnished	442XRAHX-*3 (1)	187 I	Opp	131				Furnished
489XUAHX-*5 (1)	126 I	Opp	194				Furnished	442XSAHX-*3 (1)	156 I	Opp	156				Furnished
489XWAHX-*5 (1)	107 I	Opp	229				Furnished	442XUAHX-*3 (1)	132 I	Opp	186				Furnished
489XXAHX-*5 (1)	91 I	Opp	271				Furnished	442XWAHX-*3 (1)	112 I	Opp	219				Furnished
680XFAHX-*3 (10)	288 I	Opp	85				Furnished	442XXAHX-*3 (1)	94 I	Opp	259				Furnished
680XHAHX-*3 (20)	249 I	Opp	99				Furnished	660XFAHX-*3 (10)	301 I	Opp	81				Furnished
680XQAHX-*3 (11)	206 I	Opp	118				Furnished	660XHAHX-*3 (15)	260 I	Opp	94				Furnished
680XRAHX-*3 (19)	178 I	Opp	137				Furnished	660XQAHX-*3 (11)	216 I	Opp	113				Furnished
680XSAHX-*3 (14)	150 I	Opp	163				Furnished	660XRAHX-*3 (19)	187 I	Opp	131				Furnished
823XBAHX-*3 (40)	423 I	Opp	58				Furnished	660XSAHX-*3 (14)	156 I	Opp	156				Furnished
823XDAHX-*3 (44)	357 I	Opp	69				Furnished								
823XGAHX-*3 (45)	329 I	Opp	74				Furnished								
823XJAHX-*3 (41)	279 I	Opp	88				Furnished								
823XMAHX-*3 (39)	238 I	Opp	103				Furnished								
823XRAHX-*3 (43)	172 I	Opp	142				Furnished								
823XTKTX-*3 (17)	142 I	Opp	172		8-A-165(46)		Furnished								
880XBAHX-*3 (3)	423 I	Opp	58				Furnished								
880XDAHX-*3 (4)	357 I	Opp	69				Furnished								
880XGAHX-*3 (9)	329 I	Opp	74				Furnished								
880XJAHX-*3 (5)	279 I	Opp	88				Furnished								
880XMAHX-*3 (6)	238 I	Opp	103				Furnished								
880XQAHX-*3 (16)	203 I	Opp	120				Furnished								

Continued on Next Page

† I = Intermittent Torque Only - De-rate Torque Rating 30% for Continuous Duty.

C = Continuous or Intermittent Torque - No need to De-Rate Torque Rating.

IMPORTANT: Refer to the back of this transmission section and read all notes associated with this application page. Some notes may affect the proper PTO selection.

CAUTION: Eaton Transmission Division has established a Maximum Torque Limit for the Transmission PTO Driver Gear. For all RT/RTO/RTLO transmissions the torque limit is 350 lb-ft [475 Nm] unless the transmission has been upgraded to a roller type input shaft bearing, Eaton part number 4301417, then 750 lb-ft [1017 Nm] torque becomes the Maximum limit. All torque limits on this application page reflect the 350 lb-ft [475 Nm] limit at the Transmission PTO Drive Gear. Refer to the Chelsea PTO Torque Limit Chart in the front of this section for complete torque limit information.

CAUTION: Do not use geared adapters with 442 A and C ratios.

(1) Input Gear Part No. 5-P-1004	(6) Input Gear Part No. 5-P-1103	(13) Input Gear Part No. 5-P-1287	(18) Input Gear Part No. 5-P-1418	(41) Input Gear Part No. 5-P-325
(2) Input Gear Part No. 5-P-1077	(9) Input Gear Part No. 5-P-1135	(14) Input Gear Part No. 5-P-1322	(19) Input Gear Part No. 5-P-1441	(43) Input Gear Part No. 5-P-721
(3) Input Gear Part No. 5-P-1100	(10) Input Gear Part No. 5-P-1242	(15) Input Gear Part No. 5-P-1364	(20) Input Gear Part No. 5-P-1494	(44) Input Gear Part No. 5-P-971
(4) Input Gear Part No. 5-P-1101	(11) Input Gear Part No. 5-P-1246	(16) Input Gear Part No. 5-P-1385	(39) Input Gear Part No. 5-P-283	(45) Input Gear Part No. 5-P-980
(5) Input Gear Part No. 5-P-1102	(12) Input Gear Part No. 5-P-1280	(17) Input Gear Part No. 5-P-1395	(40) Input Gear Part No. 5-P-285	(46) Filler block furnished with PTO



October 2022
5.5.16

Parker Hannifin Corporation
Chelsea Products Division
Olive Branch, MS 38654 USA

CHELSEA®

EATON FULLER

FLR-34

RT-11609A (Thruhaft option use "AT" mounting)
RT-11709H (Thruhaft option use "AU" mounting)
RT-12609A (Thruhaft option use "AT" mounting)
RT-12709A
RT-12710B (Thruhaft option use "AU" mounting)
RT-13609A (Thruhaft option use "AT" mounting)
RT-13709H (Thruhaft option use "AU" mounting)
RT-13710B (Thruhaft option use "AU" mounting)

RT-14609A (Thruhaft option use "AU" mounting)
RT-14709A
RT-14710B (Thruhaft option use "AU" mounting)
RT-14710B-AS2
RT-14715 (Thruhaft option use "BD" mounting)
RT-14910B-AS2
RT-14915
RT-15715

RT-8709B
RT-8908LL
RT-9710B (Thruhaft option use "AU" mounting)
RTA-14710B-AS
RTF-11609A
RTF-12609A
RTF-12709H
RTF-12710B

BOTTOM SIDE ONLY

RIGHT SIDE ONLY

TRANSMISSION GEAR DATA:

BOT 08-BOLT Opening Gear FORWARD of Centerline
47 Teeth - SPUR

PITCH LINE TO APERTURE FACE:

0.8050" (20.4500MM)

TRANSMISSION GEAR DATA:

R.S. 06-BOLT Opening Gear FORWARD of Centerline
45 Teeth - SPUR

PITCH LINE TO APERTURE FACE:

1.0850" (27.5600MM)

CAUTION: Application Approval Required for PTO Output Shaft Speeds Above 2500 RPM

PTO Model	Torq I / C †	Dir Rot	Engine %		Filler Block	Adapter Assy	Stud Kit	PTO Model	Torq I / C †	Dir Rot	Engine %		Filler Block	Adapter Assy	Stud Kit
			Fwd	Rev							Fwd	Rev			

ONE SPEED - TWO GEAR - MECHANICAL SHIFT

880XRAHX-*3 (7)	172 I	Opp	142				Furnished								
880XTAHX-*3 (8)	134 I	Opp	183				Furnished								

ONE SPEED - TWO GEAR POWERSHIFT (AIR OR HYDRAULIC)

272XAAJX-*3 (30)	300 C	Opp	47			328481X	Furnished	272XAAJX-*3 (30)	300 C	Opp	45				Furnished
282XBAJX-*3 (21)	300 C	Opp	58		8-A-032		Furnished	272XBAJX-*3 (31)	300 C	Opp	55				Furnished
282XCAJX-*3 (22)	300 C	Opp	70		8-A-032		Furnished	272XCAJX-*3 (32)	300 C	Opp	67				Furnished
282XDAJX-*3 (23)	293 C	Opp	84		8-A-032		Furnished	272XDAJX-*3 (33)	300 C	Opp	79				Furnished
282XGAJX-*3 (24)	257 C	Opp	95		8-A-032		Furnished	272XGAJX-*3 (34)	300 C	Opp	95				Furnished
282XKAJX-*3 (25)	220 C	Opp	112		8-A-032		Furnished	272XKAJX-*3 (35)	300 C	Opp	106				Furnished
282XMAJX-*3 (26)	206 C	Opp	119		8-A-032		Furnished	272XMAJX-*3 (36)	300 C	Opp	119				Furnished
282XPAJX-*3 (27)	184 C	Opp	133		8-A-032		Furnished	272XPAJX-*3 (37)	300 C	Opp	133				Furnished
282XSAJX-*3 (28)	158 C	Opp	156		8-A-032		Furnished	272XSAJX-*3 (38)	300 C	Opp	149				Furnished
282XTAJX-*3 (29)	147 C	Opp	166		8-A-032		Furnished								

ONE SPEED - TWO GEAR - POWERSHIFT (AIR)

885XBAHX-*3 (3)	423 I	Opp	58				Furnished								
885XGAHX-*3 (9)	329 I	Opp	74				Furnished								
885XJAHX-*3 (5)	279 I	Opp	88				Furnished								
885XMAHX-*3 (6)	238 I	Opp	103				Furnished								

ONE SPEED - FORWARD & REVERSE

348XFAHX-*5 (42)	200 I	Opp	74	78			Furnished	340XFAHX-*5 (42)	200 I	Opp	71	75	7-A-140(46)		Furnished
863XBAHX-*5	423 I	Opp	58	72			Furnished								

GEARED ADAPTERS

628XAHX-4AH	250 I	Eng			8-A-032		Furnished	626XAHX-3AH	250 I	Eng					Furnished
								630XAHX-3AH	250 I	Eng					Furnished
								645XAHX-3AH	250 I	Eng					Furnished

Continued on Next Page

† I = Intermittent Torque Only - De-rate Torque Rating 30% for Continuous Duty.

C = Continuous or Intermittent Torque - No need to De-Rate Torque Rating.

IMPORTANT: Refer to the back of this transmission section and read all notes associated with this application page. Some notes may affect the proper PTO selection.

CAUTION: Eaton Transmission Division has established a Maximum Torque Limit for the Transmission PTO Driver Gear. For all RT/RTO/RTLO transmissions the torque limit is 350 lb-ft [475 Nm] unless the transmission has been upgraded to a roller type input shaft bearing, Eaton part number 4301417, then 750 lb-ft [1017 Nm] torque becomes the Maximum limit. All torque limits on this application page reflect the 350 lb-ft [475 Nm] limit at the Transmission PTO Drive Gear. Refer to the Chelsea PTO Torque Limit Chart in the front of this section for complete torque limit information.

CAUTION: Do not use geared adapters with 442 A and C ratios.

(3) Input Gear Part No. 5-P-1100	(21) Input Gear Part No. 5-P-1510-11X	(27) Input Gear Part No. 5-P-1510-17X	(33) Input Gear Part No. 5-P-1510-4X	(42) Input Gear Part No. 5-P-581
(5) Input Gear Part No. 5-P-1102	(22) Input Gear Part No. 5-P-1510-12X	(28) Input Gear Part No. 5-P-1510-18X	(34) Input Gear Part No. 5-P-1510-5X	(46) Filler block furnished with PTO
(6) Input Gear Part No. 5-P-1103	(23) Input Gear Part No. 5-P-1510-13X	(29) Input Gear Part No. 5-P-1510-19X	(35) Input Gear Part No. 5-P-1510-6X	
(7) Input Gear Part No. 5-P-1104	(24) Input Gear Part No. 5-P-1510-14X	(30) Input Gear Part No. 5-P-1510-1X	(36) Input Gear Part No. 5-P-1510-7X	
(8) Input Gear Part No. 5-P-1105	(25) Input Gear Part No. 5-P-1510-15X	(31) Input Gear Part No. 5-P-1510-2X	(37) Input Gear Part No. 5-P-1510-8X	
(9) Input Gear Part No. 5-P-1135	(26) Input Gear Part No. 5-P-1510-16X	(32) Input Gear Part No. 5-P-1510-3X	(38) Input Gear Part No. 5-P-1510-9X	

FLR-34

EATON FULLER



RT-11609A (Thrushaft option use "AT" mounting)	RT-14609A (Thrushaft option use "AU" mounting)	RT-8709B
RT-11709H (Thrushaft option use "AU" mounting)	RT-14709A	RT-8908LL
RT-12609A (Thrushaft option use "AT" mounting)	RT-14710B (Thrushaft option use "AU" mounting)	RT-9710B (Thrushaft option use "AU" mounting)
RT-12709A	RT-14710B-AS2	RTA-14710B-AS
RT-12710B (Thrushaft option use "AU" mounting)	RT-14715 (Thrushaft option use "BD" mounting)	RTF-11609A
RT-13609A (Thrushaft option use "AT" mounting)	RT-14910B-AS2	RTF-12609A
RT-13709H (Thrushaft option use "AU" mounting)	RT-14915	RTF-12709H
RT-13710B (Thrushaft option use "AU" mounting)	RT-15715	RTF-12710B

REAR SIDE ONLY

TRANSMISSION GEAR DATA:

REAR 03-BOLT Opening

PITCH LINE TO APERTURE FACE:

CAUTION: Application Approval Required for PTO Output Shaft Speeds Above 2500 RPM

PTO Model	Torq	Dir Rot	Engine %		Filler Block	Adapter Assy	Stud Kit	PTO Model	Torq	Dir Rot	Engine %		Filler Block	Adapter Assy	Stud Kit
	I / C †		Fwd	Rev					I / C †		Fwd	Rev			

REAR MOUNT - AU MOUNTING OPTION

541-LAU-*.*	400 I	Eng	67			Furnished
541-MAU-*.*	350 I	Eng	87			Furnished
541-NAU-*.*	300 I	Eng	99			Furnished

REAR MOUNT - BD MOUNTING OPTION

541-LBD-*.*	400 I	Eng	67			Furnished
541-MBD-*.*	350 I	Eng	87			Furnished
541-NBD-*.*	300 I	Eng	99			Furnished

† I = Intermittent Torque Only - De-rate Torque Rating 30% for Continuous Duty.

C = Continuous or Intermittent Torque - No need to De-Rate Torque Rating.

IMPORTANT: Refer to the back of this transmission section and read all notes associated with this application page. Some notes may affect the proper PTO selection.

CAUTION: Eaton Transmission Division has established a Maximum Torque Limit for the Transmission PTO Driver Gear. For all RT/RTO/RTLO transmissions the torque limit is 350 lb-ft [475 Nm] unless the transmission has been upgraded to a roller type input shaft bearing, Eaton part number 4301417, then 750 lb-ft [1017 Nm] torque becomes the Maximum limit. All torque limits on this application page reflect the 350 lb-ft [475 Nm] limit at the Transmission PTO Drive Gear. Refer to the Chelsea PTO Torque Limit Chart in the front of this section for complete torque limit information.

CAUTION: Do not use geared adapters with 442 A and C ratios.

Eaton Fuller

CHELSEA®

EATON FULLER

FLR-40

RT-613
RT-6610
RT-6613
RTO-7613

BOTTOM SIDE ONLY

RIGHT SIDE ONLY

TRANSMISSION GEAR DATA:

BOT 08-BOLT Opening Gear REAR of Centerline
33 Teeth - SPUR

PITCH LINE TO APERTURE FACE:

0.8050" (20.4500MM)

TRANSMISSION GEAR DATA:

R.S. 06-BOLT Opening Gear REAR of Centerline
33 Teeth - SPUR

PITCH LINE TO APERTURE FACE:

1.0850" (27.5600MM)

CAUTION: Application Approval Required for PTO Output Shaft Speeds Above 2500 RPM

PTO Model	Torq I / C †	Dir Rot	Engine %		Filler Block	Adapter Assy	Stud Kit	PTO Model	Torq I / C †	Dir Rot	Engine %		Filler Block	Adapter Assy	Stud Kit
			Fwd	Rev							Fwd	Rev			

ONE SPEED - TWO GEAR - MECHANICAL SHIFT

221ZCAHX-*6	250 I	Opp	44		7-A-032(P)(27)	328564X	Furnished	221XCAHX-*6	250 I	Opp	44		7-A-032(27)	Furnished	
221ZEAHX-*6	250 I	Opp	51			328564X	Furnished	221XEAHX-*6	250 I	Opp	51			Furnished	
489XAAHX-*6 (12)	250 I	Opp	41				Furnished	442XFAHX-*6 (2)	250 I	Opp	62			Furnished	
489XCAHX-*6 (13)	250 I	Opp	50				Furnished	442XHAHX-*6 (15)	250 I	Opp	72			Furnished	
489XFAHX-*6 (2)	250 I	Opp	62				Furnished	442XLAHX-*6 (1)	250 I	Opp	80			Furnished	
489XHAHX-*6 (15)	250 I	Opp	72				Furnished	442XQAHX-*6 (1)	225 I	Opp	86			Furnished	
489XLAHX-*6 (1)	250 I	Opp	80				Furnished	442XRAHX-*6 (1)	225 I	Opp	99			Furnished	
489XQAHX-*6 (1)	225 I	Opp	86				Furnished	442XSAHX-*6 (1)	200 I	Opp	118			Furnished	
489XRAHX-*6 (1)	225 I	Opp	99				Furnished	442XUAHX-*6 (1)	195 I	Opp	141			Furnished	
489XSAHX-*6 (1)	200 I	Opp	118				Furnished	442XWAHX-*6 (1)	175 I	Opp	166			Furnished	
489XUAHX-*6 (1)	195 I	Opp	141				Furnished	442XXAHX-*6 (1)	140 I	Opp	196			Furnished	
489XWAHX-*6 (1)	175 I	Opp	166				Furnished	660XFAHX-*6 (10)	375 I	Opp	62			Furnished	
489XXAHX-*6 (1)	140 I	Opp	196				Furnished	660XHAHX-*6 (15)	375 I	Opp	72			Furnished	
680XFAHX-*6 (10)	375 I	Opp	62				Furnished	660XQAHX-*6 (11)	375 I	Opp	86			Furnished	
680XHAHX-*6 (19)	375 I	Opp	72				Furnished	660XRAHX-*6 (18)	350 I	Opp	99			Furnished	
680XQAHX-*6 (11)	375 I	Opp	86				Furnished	660XSAHX-*6 (14)	325 I	Opp	118			Furnished	
680XRAHX-*6 (18)	350 I	Opp	99				Furnished								
680XSAHX-*6 (14)	325 I	Opp	118				Furnished								
823XBAHX-*6 (21)	500 I	Opp	42				Furnished								
823XDAHX-*6 (25)	500 I	Opp	50				Furnished								
823XGAHX-*6 (26)	500 I	Opp	54				Furnished								
823XJAHX-*6 (22)	500 I	Opp	64				Furnished								
823XMAHX-*6 (20)	500 I	Opp	75				Furnished								
823XRAHX-*6 (24)	400 I	Opp	103				Furnished								
823XTKTX-*6 (17)	372 I	Opp	125		8-A-165(27)		Furnished								
880XBAHX-*6 (3)	500 I	Opp	42				Furnished								
880XDAHX-*6 (4)	500 I	Opp	50				Furnished								
880XGAHX-*6 (9)	500 I	Opp	54				Furnished								
880XJAHX-*6 (5)	500 I	Opp	64				Furnished								
880XMAHX-*6 (6)	500 I	Opp	75				Furnished								
880XQAHX-*6 (16)	450 I	Opp	87				Furnished								

Continued on Next Page

† I = Intermittent Torque Only - De-rate Torque Rating 30% for Continuous Duty.

C = Continuous or Intermittent Torque - No need to De-Rate Torque Rating.

IMPORTANT: Refer to the back of this transmission section and read all notes associated with this application page.
Some notes may affect the proper PTO selection.

CAUTION: Do not use geared adapters with 442 A and C ratios.

- (1) Input Gear Part No. 5-P-1004
(2) Input Gear Part No. 5-P-1077
(3) Input Gear Part No. 5-P-1100
(4) Input Gear Part No. 5-P-1101
(5) Input Gear Part No. 5-P-1102

- (6) Input Gear Part No. 5-P-1103
(9) Input Gear Part No. 5-P-1135
(10) Input Gear Part No. 5-P-1242
(11) Input Gear Part No. 5-P-1246
(12) Input Gear Part No. 5-P-1280

- (13) Input Gear Part No. 5-P-1287
(14) Input Gear Part No. 5-P-1322
(15) Input Gear Part No. 5-P-1364
(16) Input Gear Part No. 5-P-1385
(17) Input Gear Part No. 5-P-1395

- (18) Input Gear Part No. 5-P-1441
(19) Input Gear Part No. 5-P-1494
(20) Input Gear Part No. 5-P-283
(21) Input Gear Part No. 5-P-285
(22) Input Gear Part No. 5-P-325

- (24) Input Gear Part No. 5-P-721
(25) Input Gear Part No. 5-P-971
(26) Input Gear Part No. 5-P-980
(27) Filler block furnished with PTO

FLR-40

EATON FULLER

CHELSEA®

RT-613
RT-6610
RT-6613
RTO-7613

BOTTOM SIDE ONLY

RIGHT SIDE ONLY

TRANSMISSION GEAR DATA:

BOT 08-BOLT Opening Gear REAR of Centerline
33 Teeth - SPUR

PITCH LINE TO APERTURE FACE:

0.8050" (20.4500MM)

TRANSMISSION GEAR DATA:

R.S. 06-BOLT Opening Gear REAR of Centerline
33 Teeth - SPUR

PITCH LINE TO APERTURE FACE:

1.0850" (27.5600MM)

CAUTION: Application Approval Required for PTO Output Shaft Speeds Above 2500 RPM

PTO Model	Torq I / C †	Dir Rot	Engine %		Filler Block	Adapter Assy	Stud Kit	PTO Model	Torq I / C †	Dir Rot	Engine %		Filler Block	Adapter Assy	Stud Kit
			Fwd	Rev							Fwd	Rev			
ONE SPEED - TWO GEAR - MECHANICAL SHIFT															
880XRAHX-*6 (7)	400 I	Opp	103				Furnished								
880XTAHX-*6 (8)	350 I	Opp	133				Furnished								
ONE SPEED - TWO GEAR - POWERSHIFT (AIR)															
885XBAHX-*6 (3)	500 I	Opp	42				Furnished								
885XGAHX-*6 (9)	500 I	Opp	54				Furnished								
885XJAHX-*6 (5)	500 I	Opp	64				Furnished								
885XMAHX-*6 (6)	500 I	Opp	75				Furnished								
ONE SPEED - FORWARD & REVERSE															
348XFAHX-*4 (23)	200 I	Opp	54	56			Furnished	340XFAHX-*4 (23)	200 I	Opp	54	56	7-A-140(27)		Furnished
863XBAHX-*4	500 I	Opp	42	52			Furnished								
GEARED ADAPTERS															
628XAHX-4AH	250 I	Eng			8-A-032		Furnished	626XAHX-4AH	250 I	Eng					Furnished
								630XAHX-4AH	250 I	Eng					Furnished
								645XAHX-4AH	250 I	Eng					Furnished

† I = Intermittent Torque Only - De-rate Torque Rating 30% for Continuous Duty.

C = Continuous or Intermittent Torque - No need to De-Rate Torque Rating.

IMPORTANT: Refer to the back of this transmission section and read all notes associated with this application page.
Some notes may affect the proper PTO selection.**CAUTION:** Do not use geared adapters with 442 A and C ratios.(3) Input Gear Part No. 5-P-1100
(5) Input Gear Part No. 5-P-1102
(6) Input Gear Part No. 5-P-1103
(7) Input Gear Part No. 5-P-1104
(8) Input Gear Part No. 5-P-1105(9) Input Gear Part No. 5-P-1135
(23) Input Gear Part No. 5-P-581
(27) Filler block furnished with PTO

CHELSEA®

EATON FULLER

FLR-41

RTO-6610
RTO-6613

BOTTOM SIDE ONLY

RIGHT SIDE ONLY

TRANSMISSION GEAR DATA:

BOT 08-BOLT Opening Gear REAR of Centerline
33 Teeth - SPUR

PITCH LINE TO APERTURE FACE:

0.8050" (20.4500MM)

TRANSMISSION GEAR DATA:

R.S. 06-BOLT Opening Gear REAR of Centerline
33 Teeth - SPUR

PITCH LINE TO APERTURE FACE:

1.0850" (27.5600MM)

CAUTION: Application Approval Required for PTO Output Shaft Speeds Above 2500 RPM

PTO Model	Torq I / C †	Dir Rot	Engine %		Filler Block	Adapter Assy	Stud Kit	PTO Model	Torq I / C †	Dir Rot	Engine %		Filler Block	Adapter Assy	Stud Kit
			Fwd	Rev							Fwd	Rev			

ONE SPEED - TWO GEAR - MECHANICAL SHIFT

221ZCAHX-*6	250 I	Opp	55		7-A-032(P)(25)	328564X	Furnished	221XCAHX-*6	250 I	Opp	55		7-A-032(25)		Furnished
221ZEAHX-*6	250 I	Opp	63			328564X	Furnished	221XEAHX-*6	250 I	Opp	63				Furnished
489XFAHX-*6 (2)	250 I	Opp	76				Furnished	442XFAHX-*6 (2)	250 I	Opp	76				Furnished
489XHAHX-*6 (13)	250 I	Opp	88				Furnished	442XHAHX-*6 (13)	250 I	Opp	88				Furnished
489XLAHX-*6 (1)	250 I	Opp	99				Furnished	442XLAHX-*6 (1)	250 I	Opp	99				Furnished
489XQAHX-*6 (1)	225 I	Opp	106				Furnished	442XQAHX-*6 (1)	225 I	Opp	106				Furnished
489XRAHX-*6 (1)	225 I	Opp	123				Furnished	442XRAHX-*6 (1)	225 I	Opp	123				Furnished
489XSAHX-*6 (1)	200 I	Opp	147				Furnished	442XSAHX-*6 (1)	200 I	Opp	147				Furnished
489XUAHX-*6 (1)	195 I	Opp	175				Furnished	442XUAHX-*6 (1)	195 I	Opp	175				Furnished
489XWAHX-*6 (1)	175 I	Opp	206				Furnished	442XWAHX-*6 (1)	175 I	Opp	206				Furnished
489XXAHX-*6 (1)	140 I	Opp	243				Furnished	442XXAHX-*6 (1)	140 I	Opp	243				Furnished
680XFAHX-*6 (10)	375 I	Opp	76				Furnished	660XFAHX-*6 (10)	375 I	Opp	76				Furnished
680XHAHX-*6 (17)	375 I	Opp	88				Furnished	660XHAHX-*6 (13)	375 I	Opp	88				Furnished
680XQAHX-*6 (11)	375 I	Opp	106				Furnished	660XQAHX-*6 (11)	375 I	Opp	106				Furnished
680XRAHX-*6 (16)	350 I	Opp	123				Furnished	660XRAHX-*6 (16)	350 I	Opp	123				Furnished
680XSAHX-*6 (12)	325 I	Opp	147				Furnished	660XSAHX-*6 (12)	325 I	Opp	147				Furnished
823XBAHX-*6 (19)	500 I	Opp	52				Furnished								
823XDAHX-*6 (23)	500 I	Opp	62				Furnished								
823XGAHX-*6 (24)	500 I	Opp	67				Furnished								
823XJAHX-*6 (20)	500 I	Opp	79				Furnished								
823XMAHX-*6 (18)	500 I	Opp	92				Furnished								
823XRAHX-*6 (22)	400 I	Opp	128				Furnished								
823XTKTX-*6 (15)	372 I	Opp	154		8-A-165(25)		Furnished								
880XBAHX-*6 (3)	500 I	Opp	52				Furnished								
880XDAHX-*6 (4)	500 I	Opp	62				Furnished								
880XGAHX-*6 (9)	500 I	Opp	67				Furnished								
880XJAHX-*6 (5)	500 I	Opp	79				Furnished								
880XMAHX-*6 (6)	500 I	Opp	92				Furnished								
880XQAHX-*6 (14)	450 I	Opp	109				Furnished								
880XRAHX-*6 (7)	400 I	Opp	128				Furnished								
880XTAHX-*6 (8)	350 I	Opp	164				Furnished								

Continued on Next Page

† I = Intermittent Torque Only - De-rate Torque Rating 30% for Continuous Duty.

C = Continuous or Intermittent Torque - No need to De-Rate Torque Rating.

IMPORTANT: Refer to the back of this transmission section and read all notes associated with this application page.
Some notes may affect the proper PTO selection.

CAUTION: Do not use geared adapters with 442 A and C ratios.

- (1) Input Gear Part No. 5-P-1004
(2) Input Gear Part No. 5-P-1077
(3) Input Gear Part No. 5-P-1100
(4) Input Gear Part No. 5-P-1101
(5) Input Gear Part No. 5-P-1102

- (6) Input Gear Part No. 5-P-1103
(7) Input Gear Part No. 5-P-1104
(8) Input Gear Part No. 5-P-1105
(9) Input Gear Part No. 5-P-1135
(10) Input Gear Part No. 5-P-1242

- (11) Input Gear Part No. 5-P-1246
(12) Input Gear Part No. 5-P-1322
(13) Input Gear Part No. 5-P-1364
(14) Input Gear Part No. 5-P-1385
(15) Input Gear Part No. 5-P-1395

- (16) Input Gear Part No. 5-P-1441
(17) Input Gear Part No. 5-P-1494
(18) Input Gear Part No. 5-P-283
(19) Input Gear Part No. 5-P-285
(20) Input Gear Part No. 5-P-325

- (22) Input Gear Part No. 5-P-721
(23) Input Gear Part No. 5-P-971
(24) Input Gear Part No. 5-P-980
(25) Filler block furnished with PTO

FLR-41

EATON FULLER

CHELSEA®

RTO-6610
RTO-6613

BOTTOM SIDE ONLY

REAR SIDE ONLY

TRANSMISSION GEAR DATA:

BOT 08-BOLT Opening Gear REAR of Centerline
33 Teeth - SPUR

PITCH LINE TO APERTURE FACE:

0.8050" (20.4500MM)

TRANSMISSION GEAR DATA:

R.S. 06-BOLT Opening Gear REAR of Centerline
33 Teeth - SPUR

PITCH LINE TO APERTURE FACE:

1.0850" (27.5600MM)

CAUTION: Application Approval Required for PTO Output Shaft Speeds Above 2500 RPM

PTO Model	Torq	Dir Rot	Engine %		Filler Block	Adapter Assy	Stud Kit	PTO Model	Torq	Dir Rot	Engine %		Filler Block	Adapter Assy	Stud Kit
	I / C †		Fwd	Rev					I / C †		Fwd	Rev			

ONE SPEED - TWO GEAR - POWERSHIFT (AIR)

885XBAHX-*6 (3)	500 I	Opp	52				Furnished
885XGAHX-*6 (9)	500 I	Opp	67				Furnished
885XJAHX-*6 (5)	500 I	Opp	79				Furnished
885XMAHX-*6 (6)	500 I	Opp	92				Furnished

ONE SPEED - FORWARD & REVERSE

348XFAHX-*4 (21)	200 I	Opp	67	70			Furnished	340XFAHX-*4 (21)	200 I	Opp	67	70	7-A-140(25)		Furnished
863XBAHX-*4	500 I	Opp	52	64			Furnished								

GEARED ADAPTERS

628XAHX-4AH	250 I	Eng					Furnished	626XAHX-4AH	250 I	Eng					Furnished
								630XAHX-4AH	250 I	Eng					Furnished
								645XAHX-4AH	250 I	Eng					Furnished

† I = Intermittent Torque Only - De-rate Torque Rating 30% for Continuous Duty.

C = Continuous or Intermittent Torque - No need to De-Rate Torque Rating.

IMPORTANT: Refer to the back of this transmission section and read all notes associated with this application page. Some notes may affect the proper PTO selection.

CAUTION: Do not use geared adapters with 442 A and C ratios.

- (3) Input Gear Part No. 5-P-1100
- (5) Input Gear Part No. 5-P-1102
- (6) Input Gear Part No. 5-P-1103
- (9) Input Gear Part No. 5-P-1135
- (21) Input Gear Part No. 5-P-581

(25) Filler block furnished with PTO

CHELSEA®

EATON FULLER

FLR-57

RTAO-10710B-AC RTAO-10710B-AS RTAO-12710B-AC RTAO-12710B-AS RTAO-14710B-AC RTAO-14710B-AS RTAO-14710B-AS RTAO-16710B-AC	RTAO-16710B-AS RTO-10710B-AS2 RTO-10910B-AS2 RTO-10910B-AS3 RTO-11908LL RTO-12710B-AS2 RTO-12910B-AS2 (Thrustaft option use AT mounting) RTO-12910B-AS3 (Thrustaft option use AT mounting)	RTO-14710B-AS2 RTO-14908LL RTO-14910B-AS2 RTO-14910B-AS3 RTO-16710B RTO-16710B-AS2 RTO-16908LL (Thrustaft use BD mounting) RTO-16910B-AS2
--	---	--

BOTTOM SIDE ONLY	RIGHT SIDE ONLY
TRANSMISSION GEAR DATA: BOT 08-BOLT Opening Gear FORWARD of Centerline 47 Teeth - SPUR PITCH LINE TO APERTURE FACE: 0.8050" (20.4500MM)	TRANSMISSION GEAR DATA: R.S. 06-BOLT Opening Gear FORWARD of Centerline 45 Teeth - SPUR PITCH LINE TO APERTURE FACE: 1.0850" (27.5600MM)

CAUTION: Application Approval Required for PTO Output Shaft Speeds Above 2500 RPM

PTO Model	Torq I / C †	Dir Rot	Engine %		Filler Block	Adapter Assy	Stud Kit	PTO Model	Torq I / C †	Dir Rot	Engine %		Filler Block	Adapter Assy	Stud Kit
			Fwd	Rev							Fwd	Rev			

ONE SPEED - TWO GEAR - MECHANICAL SHIFT

221ZCAHX-*3	250 I	Opp	82		7-A-032(P)(46)	328564X	Furnished	221XCAHX-*3	250 I	Opp	79		7-A-032(46)		Furnished
221ZEAHX-*3	250 I	Opp	95			328564X	Furnished	221XEAHX-*3	250 I	Opp	91				Furnished
489XAAHX-*5 (12)	250 I	Opp	72				Furnished	442XAAHX-*3 (12)	250 I	Opp	69				Furnished
489XCAHX-*5 (13)	250 I	Opp	93				Furnished	442XBAHX-*3 (18)	250 I	Eng	69		REQUIRED		Furnished
489XFAHX-*5 (2)	250 I	Opp	114				Furnished	442XCAHX-*3 (13)	250 I	Opp	89				Furnished
489XHAHX-*5 (15)	250 I	Opp	132				Furnished	442XFAHX-*3 (2)	250 I	Opp	110				Furnished
489XLAHX-*5 (1)	222 I	Opp	148				Furnished	442XHAAHX-*3 (15)	250 I	Opp	127				Furnished
489XQAHX-*5 (1)	206 I	Opp	160				Furnished	442XLAHX-*3 (1)	233 I	Opp	142				Furnished
489XRAHX-*5 (1)	178 I	Opp	185				Furnished	442XQAHX-*3 (1)	216 I	Opp	153				Furnished
489XSAHX-*5 (1)	150 I	Opp	220				Furnished	442XRAHX-*3 (1)	187 I	Opp	177				Furnished
489XUAHX-*5 (1)	126 I	Opp	262				Furnished	442XSAHX-*3 (1)	156 I	Opp	211				Furnished
489XWAHX-*5 (1)	107 I	Opp	308				Furnished	442XUAHX-*3 (1)	132 I	Opp	251				Furnished
489XXAHX-*5 (1)	91 I	Opp	365				Furnished	442XWAHX-*3 (1)	112 I	Opp	295				Furnished
680XFAHX-*3 (10)	288 I	Opp	114				Furnished	442XXAHX-*3 (1)	94 I	Opp	349				Furnished
680XHAHX-*3 (20)	249 I	Opp	132				Furnished	660XFAHX-*3 (10)	301 I	Opp	110				Furnished
680XQAHX-*3 (11)	206 I	Opp	160				Furnished	660XHAHX-*3 (15)	260 I	Opp	127				Furnished
680XRAHX-*3 (19)	178 I	Opp	185				Furnished	660XQAHX-*3 (11)	216 I	Opp	153				Furnished
680XSAHX-*3 (14)	150 I	Opp	220				Furnished	660XRAHX-*3 (19)	187 I	Opp	177				Furnished
823XBAHX-*3 (40)	423 I	Opp	78				Furnished	660XSAHX-*3 (14)	156 I	Opp	211				Furnished
823XDAHX-*3 (44)	357 I	Opp	92				Furnished								
823XGAHX-*3 (45)	329 I	Opp	100				Furnished								
823XJAHX-*3 (41)	279 I	Opp	118				Furnished								
823XMAHX-*3 (39)	238 I	Opp	139				Furnished								
823XRAHX-*3 (43)	172 I	Opp	191				Furnished								
823XTKTX-*3 (17)	142 I	Opp	231		8-A-165(46)		Furnished								
880XBAHX-*3 (3)	423 I	Opp	78				Furnished								
880XDAHX-*3 (4)	357 I	Opp	92				Furnished								
880XGAHX-*3 (9)	329 I	Opp	100				Furnished								
880XJAHX-*3 (5)	279 I	Opp	118				Furnished								
880XMAHX-*3 (6)	238 I	Opp	139				Furnished								
880XQAHX-*3 (16)	203 I	Opp	162				Furnished								

Continued on Next Page

† I = Intermittent Torque Only - De-rate Torque Rating 30% for Continuous Duty.

C = Continuous or Intermittent Torque - No need to De-Rate Torque Rating.

IMPORTANT: Refer to the back of this transmission section and read all notes associated with this application page. Some notes may affect the proper PTO selection.

CAUTION: Eaton Transmission Division has established a Maximum Torque Limit for the Transmission PTO Driver Gear. For all RT/RTO/RTLO transmissions the torque limit is 350 lb-ft [475 Nm] unless the transmission has been upgraded to a roller type input shaft bearing, Eaton part number 4301417, then 750 lb-ft [1017 Nm] torque becomes the Maximum limit. All torque limits on this application page reflect the 350 lb-ft [475 Nm] limit at the Transmission PTO Drive Gear. Refer to the Chelsea PTO Torque Limit Chart in the front of this section for complete torque limit information.

CAUTION: Do not use geared adapters with 442 A and C ratios.

- | | | | | |
|----------------------------------|-----------------------------------|-----------------------------------|-----------------------------------|--------------------------------------|
| (1) Input Gear Part No. 5-P-1004 | (6) Input Gear Part No. 5-P-1103 | (13) Input Gear Part No. 5-P-1287 | (18) Input Gear Part No. 5-P-1418 | (41) Input Gear Part No. 5-P-325 |
| (2) Input Gear Part No. 5-P-1077 | (9) Input Gear Part No. 5-P-1135 | (14) Input Gear Part No. 5-P-1322 | (19) Input Gear Part No. 5-P-1441 | (43) Input Gear Part No. 5-P-721 |
| (3) Input Gear Part No. 5-P-1100 | (10) Input Gear Part No. 5-P-1242 | (15) Input Gear Part No. 5-P-1364 | (20) Input Gear Part No. 5-P-1494 | (44) Input Gear Part No. 5-P-971 |
| (4) Input Gear Part No. 5-P-1101 | (11) Input Gear Part No. 5-P-1246 | (16) Input Gear Part No. 5-P-1385 | (39) Input Gear Part No. 5-P-283 | (45) Input Gear Part No. 5-P-980 |
| (5) Input Gear Part No. 5-P-1102 | (12) Input Gear Part No. 5-P-1280 | (17) Input Gear Part No. 5-P-1395 | (40) Input Gear Part No. 5-P-285 | (46) Filler block furnished with PTO |

FLR-57

EATON FULLER

CHELSEA®

RTAO-10710B-AC	RTAO-16710B-AS	RTO-14710B-AS2
RTAO-10710B-AS	RTO-10710B-AS2	RTO-14908LL
RTAO-12710B-AC	RTO-10910B-AS2	RTO-14910B-AS2
RTAO-12710B-AS	RTO-10910B-AS3	RTO-14910B-AS3
RTAO-14710B-AC	RTO-11908LL	RTO-16710B
RTAO-14710B-AS	RTO-12710B-AS2	RTO-16710B-AS2
RTAO-14710B-AS	RTO-12910B-AS2 (Thrustaft option use AT mounting)	RTO-16908LL (Thrustaft use BD mounting)
RTAO-16710B-AC	RTO-12910B-AS3 (Thrustaft option use AT mounting)	RTO-16910B-AS2

BOTTOM SIDE ONLY

RIGHT SIDE ONLY

TRANSMISSION GEAR DATA:

BOT 08-BOLT Opening Gear FORWARD of Centerline
47 Teeth - SPUR

PITCH LINE TO APERTURE FACE:

0.8050" (20.4500MM)

TRANSMISSION GEAR DATA:

R.S. 06-BOLT Opening Gear FORWARD of Centerline
45 Teeth - SPUR

PITCH LINE TO APERTURE FACE:

1.0850" (27.5600MM)

CAUTION: Application Approval Required for PTO Output Shaft Speeds Above 2500 RPM

PTO Model	Torq I / C †	Dir Rot	Engine %		Filler Block	Adapter Assy	Stud Kit	PTO Model	Torq I / C †	Dir Rot	Engine %		Filler Block	Adapter Assy	Stud Kit
			Fwd	Rev							Fwd	Rev			

ONE SPEED - TWO GEAR - MECHANICAL SHIFT

880XRAHX-*3 (7)	172 I	Opp	191				Furnished
880XTAHX-*3 (8)	134 I	Opp	246				Furnished

ONE SPEED - TWO GEAR POWERSHIFT (AIR OR HYDRAULIC)

272XAAJX-*3 (30)	300 C	Opp	63			328481X	Furnished	272XAAJX-*3 (30)	300 C	Opp	61				Furnished
282XBAJX-*3 (21)	300 C	Opp	78		8-A-032		Furnished	272XBAJX-*3 (31)	300 C	Opp	75				Furnished
282XCAJX-*3 (22)	300 C	Opp	94		8-A-032		Furnished	272XCAJX-*3 (32)	300 C	Opp	90				Furnished
282XDAJX-*3 (23)	293 C	Opp	113		8-A-032		Furnished	272XDAJX-*3 (33)	300 C	Opp	107				Furnished
282XGAJX-*3 (24)	246 C	Opp	134		8-A-032		Furnished	272XGAJX-*3 (34)	257 C	Opp	128				Furnished
282XKAJX-*3 (25)	220 C	Opp	150		8-A-032		Furnished	272XKAJX-*3 (35)	230 C	Opp	144				Furnished
282XMAJX-*3 (26)	197 C	Opp	168		8-A-032		Furnished	272XMAJX-*3 (36)	206 C	Opp	161				Furnished
282XPAJX-*3 (27)	176 C	Opp	187		8-A-032		Furnished	272XPAJX-*3 (37)	175 C	Opp	180				Furnished
282XSAJX-*3 (28)	158 C	Opp	209		8-A-032		Furnished	272XSAJX-*3 (38)	157 C	Opp	201				Furnished
282XTAJX-*3 (29)	141 C	Opp	234		8-A-032		Furnished								

ONE SPEED - TWO GEAR - POWERSHIFT (AIR)

885XBAHX-*3 (3)	423 I	Opp	78				Furnished
885XGAHX-*3 (9)	329 I	Opp	100				Furnished
885XJAHX-*3 (5)	279 I	Opp	118				Furnished
885XMAHX-*3 (6)	238 I	Opp	139				Furnished

ONE SPEED - FORWARD & REVERSE

348XFAHX-*5 (42)	200 I	Opp	100	105			Furnished	340XFAHX-*5 (42)	200 I	Opp	96	101	7-A-140(46)		Furnished
863XBAHX-*5	423 I	Opp	78	97			Furnished								

GEARED ADAPTERS

626XAHX-3AH	250 I	Eng			8-A-032		Furnished	626XAHX-3AH	250 I	Eng					Furnished
								630XAHX-3AH	250 I	Eng					Furnished
								645XAHX-3AH	250 I	Eng					Furnished

Continued on Next Page

† I = Intermittent Torque Only - De-rate Torque Rating 30% for Continuous Duty.

C = Continuous or Intermittent Torque - No need to De-Rate Torque Rating.

IMPORTANT: Refer to the back of this transmission section and read all notes associated with this application page. Some notes may affect the proper PTO selection.

CAUTION: Eaton Transmission Division has established a Maximum Torque Limit for the Transmission PTO Driver Gear. For all RT/RTO/RTLO transmissions the torque limit is 350 lb-ft [475 Nm] unless the transmission has been upgraded to a roller type input shaft bearing. Eaton part number 4301417, then 750 lb-ft [1017 Nm] torque becomes the Maximum limit. All torque limits on this application page reflect the 350 lb-ft [475 Nm] limit at the Transmission PTO Drive Gear. Refer to the Chelsea PTO Torque Limit Chart in the front of this section for complete torque limit information.

CAUTION: Do not use geared adapters with 442 A and C ratios.

(3) Input Gear Part No. 5-P-1100	(21) Input Gear Part No. 5-P-1510-11X	(27) Input Gear Part No. 5-P-1510-17X	(33) Input Gear Part No. 5-P-1510-4X	(42) Input Gear Part No. 5-P-581
(5) Input Gear Part No. 5-P-1102	(22) Input Gear Part No. 5-P-1510-12X	(28) Input Gear Part No. 5-P-1510-18X	(34) Input Gear Part No. 5-P-1510-5X	(46) Filler block furnished with PTO
(6) Input Gear Part No. 5-P-1103	(23) Input Gear Part No. 5-P-1510-13X	(29) Input Gear Part No. 5-P-1510-19X	(35) Input Gear Part No. 5-P-1510-6X	
(7) Input Gear Part No. 5-P-1104	(24) Input Gear Part No. 5-P-1510-14X	(30) Input Gear Part No. 5-P-1510-1X	(36) Input Gear Part No. 5-P-1510-7X	
(8) Input Gear Part No. 5-P-1105	(25) Input Gear Part No. 5-P-1510-15X	(31) Input Gear Part No. 5-P-1510-2X	(37) Input Gear Part No. 5-P-1510-8X	
(9) Input Gear Part No. 5-P-1135	(26) Input Gear Part No. 5-P-1510-16X	(32) Input Gear Part No. 5-P-1510-3X	(38) Input Gear Part No. 5-P-1510-9X	

CHELSEA®

EATON FULLER

FLR-57

RTAO-10710B-AC RTAO-10710B-AS RTAO-12710B-AC RTAO-12710B-AS RTAO-14710B-AC RTAO-14710B-AS RTAO-16710B-AC RTAO-16710B-AS	RTAO-16710B-AS RTO-10710B-AS2 RTO-10910B-AS2 RTO-10910B-AS3 RTO-11908LL RTO-12710B-AS2 RTO-12910B-AS2 (Thrushaft option use AT mounting) RTO-12910B-AS3 (Thrushaft option use AT mounting)	RTO-14710B-AS2 RTO-14908LL RTO-14910B-AS2 RTO-14910B-AS3 RTO-16710B RTO-16710B-AS2 RTO-16908LL (Thrushaft use BD mounting) RTO-16910B-AS2
--	---	--

REAR SIDE ONLY**TRANSMISSION GEAR DATA:**

REAR 00-BOLT Opening

PITCH LINE TO APERTURE FACE:**CAUTION: Application Approval Required for PTO Output Shaft Speeds Above 2500 RPM**

PTO Model	Torq	Dir Rot	Engine %		Filler Block	Adapter Assy	Stud Kit	PTO Model	Torq	Dir Rot	Engine %		Filler Block	Adapter Assy	Stud Kit
	I / C †		Fwd	Rev					I / C †		Fwd	Rev			

REAR MOUNT - "AU" MOUNTING OPTION

541-LAU-**-*	400 I	Eng	91				Furnished								
541-MAU-**-*	350 I	Eng	117				Furnished								
541-NAU-**-*	300 I	Eng	133				Furnished								

REAR MOUNT - "BD" MOUNTING OPTION

541-LBD-**-*	400 I	Eng	91				Furnished								
541-MBD-**-*	350 I	Eng	117				Furnished								
541-NBD-**-*	300 I	Eng	133				Furnished								

† I = Intermittent Torque Only - De-rate Torque Rating 30% for Continuous Duty.

C = Continuous or Intermittent Torque - No need to De-Rate Torque Rating.

IMPORTANT: Refer to the back of this transmission section and read all notes associated with this application page. Some notes may affect the proper PTO selection.

CAUTION: Eaton Transmission Division has established a Maximum Torque Limit for the Transmission PTO Driver Gear. For all RT/RTO/RTLO transmissions the torque limit is 350 lb-ft [475 Nm] unless the transmission has been upgraded to a roller type input shaft bearing, Eaton part number 4301417, then 750 lb-ft [1017 Nm] torque becomes the Maximum limit. All torque limits on this application page reflect the 350 lb-ft [475 Nm] limit at the Transmission PTO Drive Gear. Refer to the Chelsea PTO Torque Limit Chart in the front of this section for complete torque limit information.

CAUTION: Do not use geared adapters with 442 A and C ratios.

FLR-58

EATON FULLER



FOM-16D313E-LEP RTAO-10710C-AC RTAO-10710C-AS RTAO-12710C-AC RTAO-12710C-AS RTAO-14710C-AC RTAO-14710C-AS RTAO-16710C-AS	RTLC-16609E (Convertible 9 to 13 Speed) RTLO-12713A RTLO-13118-AMT RTLO-14713A RTLO-14713A-T2 RTLO-14718B RTLO-14718B-T2 RTLO-14918A-AS2	RTLO-14918A-AS3 RTLO-14918B RTLO-14918B-AS RTLO-16713A RTLO-16713A-T2 RTLO-16718B RTLO-16718B-T2 RTLO-16913A
---	---	---

BOTTOM SIDE ONLY	RIGHT SIDE ONLY
TRANSMISSION GEAR DATA: BOT 08-BOLT Opening Gear FORWARD of Centerline 47 Teeth - SPUR PITCH LINE TO APERTURE FACE: 0.8050" (20.4500MM)	TRANSMISSION GEAR DATA: R.S. 06-BOLT Opening Gear FORWARD of Centerline 45 Teeth - SPUR PITCH LINE TO APERTURE FACE: 1.0850" (27.5600MM)

CAUTION: Application Approval Required for PTO Output Shaft Speeds Above 2500 RPM

PTO Model	Torq l / C †	Dir Rot	Engine %		Filler Block	Adapter Assy	Stud Kit	PTO Model	Torq l / C †	Dir Rot	Engine %		Filler Block	Adapter Assy	Stud Kit
			Fwd	Rev							Fwd	Rev			

ONE SPEED - TWO GEAR - MECHANICAL SHIFT

489XAAHX-*5 (11)	250 l	Opp	61				Furnished	221XCAHX-*3	250 l	Eng	66	7-A-032(P)(45)	329138X	Furnished
489XCAHX-*5 (12)	250 l	Opp	78				Furnished	221XEAHX-*3	250 l	Eng	76		329138X	Furnished
489XFAHX-*5 (2)	250 l	Opp	96				Furnished	442XAAHX-*3 (11)	250 l	Opp	58			Furnished
489XHAHX-*5 (14)	250 l	Opp	111				Furnished	442XBAHX-*3 (17)	250 l	Eng	58		REQUIRED	Furnished
489XLAHX-*5 (1)	222 l	Opp	124				Furnished	442XCAHX-*3 (12)	250 l	Opp	74			Furnished
489XQAHX-*5 (1)	206 l	Opp	134				Furnished	442XFAHX-*3 (2)	250 l	Opp	92			Furnished
489XRAHX-*5 (1)	178 l	Opp	155				Furnished	442XHAHX-*3 (14)	250 l	Opp	107			Furnished
489XSAHX-*5 (1)	150 l	Opp	184				Furnished	442XLAHX-*3 (1)	233 l	Opp	119			Furnished
680XFAHX-*3 (9)	288 l	Opp	96				Furnished	442XQAHX-*3 (1)	216 l	Opp	128			Furnished
680XHAHX-*3 (19)	249 l	Opp	111				Furnished	442XRAHX-*3 (1)	187 l	Opp	148			Furnished
680XQAHX-*3 (10)	206 l	Opp	134				Furnished	660XFAHX-*3 (9)	301 l	Opp	92			Furnished
680XRAHX-*3 (18)	178 l	Opp	155				Furnished	660XHAHX-*3 (19)	260 l	Opp	107			Furnished
680XSAHX-*3 (13)	150 l	Opp	184				Furnished	660XQAHX-*3 (10)	216 l	Opp	128			Furnished
823XBAHX-*3 (39)	423 l	Opp	65				Furnished	660XRAHX-*3 (18)	187 l	Opp	148			Furnished
823XDAHX-*3 (43)	357 l	Opp	77				Furnished							
823XGAHX-*3 (44)	329 l	Opp	84				Furnished							
823XJAHX-*3 (40)	279 l	Opp	99				Furnished							
823XMAHX-*3 (38)	238 l	Opp	116				Furnished							
823XRAHX-*3 (42)	172 l	Opp	160				Furnished							
823XTKTX-*3 (16)	142 l	Opp	194		8-A-165(T)(45)		Furnished							
880XBAHX-*3 (3)	423 l	Opp	65				Furnished							
880XDAHX-*3 (4)	357 l	Opp	77				Furnished							
880XGAHX-*3 (8)	329 l	Opp	84				Furnished							
880XJAHX-*3 (5)	279 l	Opp	99				Furnished							
880XMAHX-*3 (6)	238 l	Opp	116				Furnished							
880XQAHX-*3 (15)	203 l	Opp	136				Furnished							
880XRAHX-*3 (7)	172 l	Opp	160				Furnished							

ONE SPEED - TWO GEAR POWERSHIFT (AIR OR HYDRAULIC)

272XAAJX-*3 (29)	300 C	Opp	54			328481X	Furnished	272XAAJX-*3 (29)	300 C	Opp	51			Furnished
282XBAJX-*3 (20)	300 C	Opp	65		8-A-032		Furnished	272XBAJX-*3 (30)	300 C	Opp	62			Furnished
282XCAJX-*3 (21)	300 C	Opp	79		8-A-032		Furnished	272XCAJX-*3 (31)	300 C	Opp	76			Furnished

Continued on Next Page

† I = Intermittent Torque Only - De-rate Torque Rating 30% for Continuous Duty.

C = Continuous or Intermittent Torque - No need to De-Rate Torque Rating.

IMPORTANT: Refer to the back of this transmission section and read all notes associated with this application page. Some notes may affect the proper PTO selection.

CAUTION: Eaton Transmission Division has established a Maximum Torque Limit for the Transmission PTO Driver Gear. For all RT/RTO/RTLO transmissions the torque limit is 350 lb-ft [475 Nm] unless the transmission has been upgraded to a roller type input shaft bearing. Eaton part number 4301417, then 750 lb-ft [1017 Nm] torque becomes the Maximum limit. All torque limits on this application page reflect the 350 lb-ft [475 Nm] limit at the Transmission PTO Drive Gear. Refer to the Chelsea PTO Torque Limit Chart in the front of this section for complete torque limit information.

CAUTION: Do not use geared adapters with 442 A and C ratios.

- | | | | | |
|----------------------------------|-----------------------------------|---------------------------------------|--------------------------------------|--------------------------------------|
| (1) Input Gear Part No. 5-P-1004 | (8) Input Gear Part No. 5-P-1135 | (15) Input Gear Part No. 5-P-1385 | (29) Input Gear Part No. 5-P-1510-1X | (43) Input Gear Part No. 5-P-971 |
| (2) Input Gear Part No. 5-P-1077 | (9) Input Gear Part No. 5-P-1242 | (16) Input Gear Part No. 5-P-1395 | (30) Input Gear Part No. 5-P-1510-2X | (44) Input Gear Part No. 5-P-980 |
| (3) Input Gear Part No. 5-P-1100 | (10) Input Gear Part No. 5-P-1280 | (17) Input Gear Part No. 5-P-1418 | (31) Input Gear Part No. 5-P-1510-3X | (45) Filler block furnished with PTO |
| (4) Input Gear Part No. 5-P-1101 | (11) Input Gear Part No. 5-P-1287 | (18) Input Gear Part No. 5-P-1441 | (38) Input Gear Part No. 5-P-283 | |
| (5) Input Gear Part No. 5-P-1102 | (12) Input Gear Part No. 5-P-1287 | (19) Input Gear Part No. 5-P-1494 | (39) Input Gear Part No. 5-P-285 | |
| (6) Input Gear Part No. 5-P-1103 | (13) Input Gear Part No. 5-P-1322 | (20) Input Gear Part No. 5-P-1510-11X | (40) Input Gear Part No. 5-P-325 | |
| (7) Input Gear Part No. 5-P-1104 | (14) Input Gear Part No. 5-P-1364 | (21) Input Gear Part No. 5-P-1510-12X | (42) Input Gear Part No. 5-P-721 | |

Eaton Fuller



October 2022
5.5.26

Parker Hannifin Corporation
Chelsea Products Division
Olive Branch, MS 38654 USA

CHELSEA®

EATON FULLER

FLR-58

FOM-16D313E-LEP RTAO-10710C-AC RTAO-10710C-AS RTAO-12710C-AC RTAO-12710C-AS RTAO-14710C-AC RTAO-14710C-AS RTAO-16710C-AS	RTL-16609E (Convertible 9 to 13 Speed) RTLO-12713A RTLO-13118-AMT RTLO-14713A RTLO-14713A-T2 RTLO-14718B RTLO-14718B-T2 RTLO-14918A-AS2	RTLO-14918A-AS3 RTLO-14918B RTLO-14918B-AS RTLO-16713A RTLO-16713A-T2 RTLO-16718B RTLO-16718B-T2 RTLO-16913A
---	--	---

BOTTOM SIDE ONLY

RIGHT SIDE ONLY

TRANSMISSION GEAR DATA:

BOT 08-BOLT Opening Gear FORWARD of Centerline
47 Teeth - SPUR

PITCH LINE TO APERTURE FACE:

0.8050" (20.4500MM)

TRANSMISSION GEAR DATA:

R.S. 06-BOLT Opening Gear FORWARD of Centerline
45 Teeth - SPUR

PITCH LINE TO APERTURE FACE:

1.0850" (27.5600MM)

CAUTION: Application Approval Required for PTO Output Shaft Speeds Above 2500 RPM

PTO Model	Torq I / C †	Dir Rot	Engine %		Filler Block	Adapter Assy	Stud Kit	PTO Model	Torq I / C †	Dir Rot	Engine %		Filler Block	Adapter Assy	Stud Kit
			Fwd	Rev							Fwd	Rev			

ONE SPEED - TWO GEAR POWERSHIFT (AIR OR HYDRAULIC)

282XDAJX-*3 (22)	293 C	Opp	93		8-A-032		Furnished	272XDAJX-*3 (32)	300 C	Opp	90				Furnished
282XGAJX-*3 (23)	246 C	Opp	112		8-A-032		Furnished	272XGAJX-*3 (33)	257 C	Opp	107				Furnished
282XKAJX-*3 (24)	220 C	Opp	125		8-A-032		Furnished	272XKAJX-*3 (34)	230 C	Opp	120				Furnished
282XMAJX-*3 (25)	197 C	Opp	140		8-A-032		Furnished	272XMAJX-*3 (35)	206 C	Opp	134				Furnished
282XPAJX-*3 (26)	176 C	Opp	156		8-A-032		Furnished	272XPAJX-*3 (36)	184 C	Opp	150				Furnished
282XSAJX-*3 (27)	158 C	Opp	174		8-A-032		Furnished	272XSAJX-*3 (37)	165 C	Opp	168				Furnished
282XTAJX-*3 (28)	141 C	Opp	195		8-A-032		Furnished								

ONE SPEED - TWO GEAR - POWERSHIFT (AIR)

885XBAHX-*3 (3)	423 I	Opp	65				Furnished								
885XGAHX-*3 (8)	329 I	Opp	84				Furnished								
885XJAHX-*3 (5)	279 I	Opp	99				Furnished								
885XMAHX-*3 (6)	238 I	Opp	116				Furnished								

ONE SPEED - FORWARD & REVERSE

348XFAHX-*5 (41)	200 I	Opp	84	88			Furnished	340XFAHX-*5 (41)	200 I	Opp	80	84	7-A-140(45)		Furnished
863XBAHX-*5	423 I	Opp	65	81			Furnished								

GEARED ADAPTERS

628XAHX-3AH	250 I	Eng			8-A-032		Furnished	626XAHX-3AH	250 I	Eng					Furnished
								630XAHX-3AH	250 I	Eng					Furnished
								645XAHX-3AH	250 I	Eng					Furnished

Continued on Next Page

† I = Intermittent Torque Only - De-rate Torque Rating 30% for Continuous Duty.

C = Continuous or Intermittent Torque - No need to De-Rate Torque Rating.

IMPORTANT: Refer to the back of this transmission section and read all notes associated with this application page. Some notes may affect the proper PTO selection.

CAUTION: Eaton Transmission Division has established a Maximum Torque Limit for the Transmission PTO Driver Gear. For all RT/RTO/RTLO transmissions the torque limit is 350 lb-ft [475 Nm] unless the transmission has been upgraded to a roller type input shaft bearing, Eaton part number 4301417, then 750 lb-ft [1017 Nm] torque becomes the Maximum limit. All torque limits on this application page reflect the 350 lb-ft [475 Nm] limit at the Transmission PTO Drive Gear. Refer to the Chelsea PTO Torque Limit Chart in the front of this section for complete torque limit information.

CAUTION: Do not use geared adapters with 442 A and C ratios.

(3) Input Gear Part No. 5-P-1100	(23) Input Gear Part No. 5-P-1510-14X	(28) Input Gear Part No. 5-P-1510-19X	(36) Input Gear Part No. 5-P-1510-8X
(5) Input Gear Part No. 5-P-1102	(24) Input Gear Part No. 5-P-1510-15X	(32) Input Gear Part No. 5-P-1510-4X	(37) Input Gear Part No. 5-P-1510-9X
(6) Input Gear Part No. 5-P-1103	(25) Input Gear Part No. 5-P-1510-16X	(33) Input Gear Part No. 5-P-1510-5X	(41) Input Gear Part No. 5-P-581
(8) Input Gear Part No. 5-P-1135	(26) Input Gear Part No. 5-P-1510-17X	(34) Input Gear Part No. 5-P-1510-6X	(45) Filler block furnished with PTO
(22) Input Gear Part No. 5-P-1510-13X	(27) Input Gear Part No. 5-P-1510-18X	(35) Input Gear Part No. 5-P-1510-7X	

FLR-58

EATON FULLER



FOM-16D313E-LEP RTAO-10710C-AC RTAO-10710C-AS RTAO-12710C-AC RTAO-12710C-AS RTAO-14710C-AC RTAO-14710C-AS RTAO-16710C-AS	RTLC-16609E (Convertible 9 to 13 Speed) RTLO-12713A RTLO-13118-AMT RTLO-14713A RTLO-14713A-T2 RTLO-14718B RTLO-14718B-T2 RTLO-14918A-AS2	RTLO-14918A-AS3 RTLO-14918B RTLO-14918B-AS RTLO-16713A RTLO-16713A-T2 RTLO-16718B RTLO-16718B-T2 RTLO-16913A
---	---	---

REAR SIDE ONLY

<p>TRANSMISSION GEAR DATA: REAR 03-BOLT Opening</p> <p>PITCH LINE TO APERTURE FACE:</p>	
---	--

CAUTION: Application Approval Required for PTO Output Shaft Speeds Above 2500 RPM

PTO Model	Torq	Dir Rot	Engine %		Filler Block	Adapter Assy	Stud Kit	PTO Model	Torq	Dir Rot	Engine %		Filler Block	Adapter Assy	Stud Kit
	I / C †		Fwd	Rev					I / C †		Fwd	Rev			

REAR MOUNT - "AU" MOUNTING OPTION

541-LAU-*.*	400 I	Eng	76				Furnished
541-MAU-*.*	350 I	Eng	98				Furnished
541-NAU-*.*	300 I	Eng	112				Furnished

REAR MOUNT - "BD" MOUNTING OPTION

541-LBD-*.*	400 I	Eng	76				Furnished
541-MBD-*.*	350 I	Eng	98				Furnished
541-NBD-*.*	300 I	Eng	112				Furnished

† I = Intermittent Torque Only - De-rate Torque Rating 30% for Continuous Duty.

C = Continuous or Intermittent Torque - No need to De-Rate Torque Rating.

IMPORTANT: Refer to the back of this transmission section and read all notes associated with this application page. Some notes may affect the proper PTO selection.

CAUTION: Eaton Transmission Division has established a Maximum Torque Limit for the Transmission PTO Driver Gear. For all RT/RTO/RTLO transmissions the torque limit is 350 lb-ft [475 Nm] unless the transmission has been upgraded to a roller type input shaft bearing, Eaton part number 4301417, then 750 lb-ft [1017 Nm] torque becomes the Maximum limit. All torque limits on this application page reflect the 350 lb-ft [475 Nm] limit at the Transmission PTO Drive Gear. Refer to the Chelsea PTO Torque Limit Chart in the front of this section for complete torque limit information.

CAUTION: Do not use geared adapters with 442 A and C ratios.

Eaton Fuller

RTO-14915
RTO-16915
RTX-14715
RTX-15715

BOTTOM SIDE ONLY

RIGHT SIDE ONLY

TRANSMISSION GEAR DATA:

BOT 08-BOLT Opening Gear FORWARD of Centerline
47 Teeth - SPUR

PITCH LINE TO APERTURE FACE:

0.8050" (20.5700MM)

TRANSMISSION GEAR DATA:

R.S. 06-BOLT Opening Gear FORWARD of Centerline
45 Teeth - SPUR

PITCH LINE TO APERTURE FACE:

1.0850" (27.5600MM)

CAUTION: Application Approval Required for PTO Output Shaft Speeds Above 2500 RPM

PTO Model	Torq I / C †	Dir Rot	Engine %		Filler Block	Adapter Assy	Stud Kit	PTO Model	Torq I / C †	Dir Rot	Engine %		Filler Block	Adapter Assy	Stud Kit
			Fwd	Rev							Fwd	Rev			

ONE SPEED - TWO GEAR - MECHANICAL SHIFT

221ZCAHX-*3	250 I	Opp	77		7-A-032(P)(46)	328564X	Furnished	221XCAHX-*3	250 I	Opp	74		7-A-032(46)		Furnished
221ZEAHX-*3	250 I	Opp	89			328564X	Furnished	221XEAHX-*3	250 I	Opp	86				Furnished
489XAAHX-*5 (12)	250 I	Opp	68				Furnished	442XAAHX-*3 (12)	250 I	Opp	65				Furnished
489XCAHX-*5 (13)	250 I	Opp	87				Furnished	442XBAHX-*3 (18)	250 I	Eng	65		REQUIRED		Furnished
489XFAHX-*5 (2)	250 I	Opp	108				Furnished	442XCAHX-*3 (13)	250 I	Opp	83				Furnished
489XHAHX-*5 (15)	250 I	Opp	125				Furnished	442XFAHX-*3 (2)	250 I	Opp	103				Furnished
489XLAHX-*5 (1)	222 I	Opp	139				Furnished	442XHAHX-*3 (15)	250 I	Opp	119				Furnished
489XQAHX-*5 (1)	206 I	Opp	150				Furnished	442XLAHX-*3 (1)	233 I	Opp	134				Furnished
489XRAHX-*5 (1)	178 I	Opp	174				Furnished	442XQAHX-*3 (1)	216 I	Opp	144				Furnished
489XSAHX-*5 (1)	150 I	Opp	207				Furnished	442XRAHX-*3 (1)	187 I	Opp	166				Furnished
489XUAHX-*5 (1)	126 I	Opp	247				Furnished	442XSAHX-*3 (1)	156 I	Opp	198				Furnished
489XWAHX-*5 (1)	107 I	Opp	290				Furnished	442XUAHX-*3 (1)	132 I	Opp	236				Furnished
489XXAHX-*5 (1)	91 I	Opp	343				Furnished	442XWAHX-*3 (1)	112 I	Opp	278				Furnished
680XFAHX-*3 (10)	288 I	Opp	108				Furnished	442XXAHX-*3 (1)	94 I	Opp	329				Furnished
680XHAHX-*3 (20)	249 I	Opp	125				Furnished	660XFAHX-*3 (10)	301 I	Opp	103				Furnished
680XQAHX-*3 (11)	206 I	Opp	150				Furnished	660XHAHX-*3 (15)	260 I	Opp	119				Furnished
680XRAHX-*3 (19)	178 I	Opp	174				Furnished	660XQAHX-*3 (11)	216 I	Opp	144				Furnished
680XSAHX-*3 (14)	150 I	Opp	207				Furnished	660XRAHX-*3 (19)	187 I	Opp	166				Furnished
823XBAHX-*3 (40)	423 I	Opp	73				Furnished	660XSAHX-*3 (14)	156 I	Opp	198				Furnished
823XDAHX-*3 (44)	357 I	Opp	87				Furnished								
823XGAHX-*3 (45)	329 I	Opp	94				Furnished								
823XJAHX-*3 (41)	279 I	Opp	111				Furnished								
823XMAHX-*3 (39)	238 I	Opp	130				Furnished								
823XRAHX-*3 (43)	172 I	Opp	180				Furnished								
823XTKTX-*3 (17)	142 I	Opp	218		8-A-165(46)		Furnished								
880XBAHX-*3 (3)	423 I	Opp	73				Furnished								
880XDAHX-*3 (4)	357 I	Opp	87				Furnished								
880XGAHX-*3 (9)	329 I	Opp	94				Furnished								
880XJAHX-*3 (5)	279 I	Opp	111				Furnished								
880XMAHX-*3 (6)	238 I	Opp	130				Furnished								
880XQAHX-*3 (16)	203 I	Opp	153				Furnished								

Continued on Next Page

† I = Intermittent Torque Only - De-rate Torque Rating 30% for Continuous Duty.

C = Continuous or Intermittent Torque - No need to De-Rate Torque Rating.

IMPORTANT: Refer to the back of this transmission section and read all notes associated with this application page. Some notes may affect the proper PTO selection.

CAUTION: Eaton Transmission Division has established a Maximum Torque Limit for the Transmission PTO Driver Gear. For all RT/RTO/RTLO transmissions the torque limit is 350 lb-ft [475 Nm] unless the transmission has been upgraded to a roller type input shaft bearing, Eaton part number 4301417, then 750 lb-ft [1017 Nm] torque becomes the Maximum limit. All torque limits on this application page reflect the 350 lb-ft [475 Nm] limit at the Transmission PTO Drive Gear. Refer to the Chelsea PTO Torque Limit Chart in the front of this section for complete torque limit information.

CAUTION: Do not use geared adapters with 442 A and C ratios.

- | | | | | |
|----------------------------------|-----------------------------------|-----------------------------------|-----------------------------------|--------------------------------------|
| (1) Input Gear Part No. 5-P-1004 | (6) Input Gear Part No. 5-P-1103 | (13) Input Gear Part No. 5-P-1287 | (18) Input Gear Part No. 5-P-1418 | (41) Input Gear Part No. 5-P-325 |
| (2) Input Gear Part No. 5-P-1077 | (9) Input Gear Part No. 5-P-1135 | (14) Input Gear Part No. 5-P-1322 | (19) Input Gear Part No. 5-P-1441 | (43) Input Gear Part No. 5-P-721 |
| (3) Input Gear Part No. 5-P-1100 | (10) Input Gear Part No. 5-P-1242 | (15) Input Gear Part No. 5-P-1364 | (20) Input Gear Part No. 5-P-1494 | (44) Input Gear Part No. 5-P-971 |
| (4) Input Gear Part No. 5-P-1101 | (11) Input Gear Part No. 5-P-1246 | (16) Input Gear Part No. 5-P-1385 | (39) Input Gear Part No. 5-P-283 | (45) Input Gear Part No. 5-P-980 |
| (5) Input Gear Part No. 5-P-1102 | (12) Input Gear Part No. 5-P-1280 | (17) Input Gear Part No. 5-P-1395 | (40) Input Gear Part No. 5-P-285 | (46) Filler block furnished with PTO |

FLR-59

EATON FULLER

CHELSEA®

RTO-14915
RTO-16915
RTX-14715
RTX-15715

BOTTOM SIDE ONLY

RIGHT SIDE ONLY

TRANSMISSION GEAR DATA:

BOT 08-BOLT Opening Gear FORWARD of Centerline
47 Teeth - SPUR

PITCH LINE TO APERTURE FACE:

0.8050" (20.5700MM)

TRANSMISSION GEAR DATA:

R.S. 06-BOLT Opening Gear FORWARD of Centerline
45 Teeth - SPUR

PITCH LINE TO APERTURE FACE:

1.0850" (27.5600MM)

CAUTION: Application Approval Required for PTO Output Shaft Speeds Above 2500 RPM

PTO Model	Torq l / C †	Dir Rot	Engine %		Filler Block	Adapter Assy	Stud Kit	PTO Model	Torq l / C †	Dir Rot	Engine %		Filler Block	Adapter Assy	Stud Kit
			Fwd	Rev							Fwd	Rev			

ONE SPEED - TWO GEAR - MECHANICAL SHIFT

880XRAHX-*3 (7)	172 l	Opp	180				Furnished								
880XTAHX-*3 (8)	134 l	Opp	232				Furnished								

ONE SPEED - TWO GEAR POWERSHIFT (AIR OR HYDRAULIC)

272XAAJX-*3 (30)	300 C	Opp	60			328481X	Furnished	272XAAJX-*3 (30)	300 C	Opp	57				Furnished
282XBAJX-*3 (21)	300 C	Opp	73		8-A-032		Furnished	272XBAJX-*3 (31)	300 C	Opp	70				Furnished
282XCAJX-*3 (22)	300 C	Opp	89		8-A-032		Furnished	272XCAJX-*3 (32)	300 C	Opp	85				Furnished
282XDAJX-*3 (23)	293 C	Opp	106		8-A-032		Furnished	272XDAJX-*3 (33)	300 C	Opp	101				Furnished
282XGAJX-*3 (24)	246 C	Opp	126		8-A-032		Furnished	272XGAJX-*3 (34)	257 C	Opp	121				Furnished
282XKAJX-*3 (25)	220 C	Opp	141		8-A-032		Furnished	272XKAJX-*3 (35)	230 C	Opp	135				Furnished
282XMAJX-*3 (26)	197 C	Opp	158		8-A-032		Furnished	272XMAJX-*3 (36)	206 C	Opp	151				Furnished
282XPAJX-*3 (27)	176 C	Opp	176		8-A-032		Furnished	272XPAJX-*3 (37)	184 C	Opp	169				Furnished
282XSAJX-*3 (28)	158 C	Opp	197		8-A-032		Furnished	272XSAJX-*3 (38)	165 C	Opp	189				Furnished
282XTAJX-*3 (29)	141 C	Opp	221		8-A-032		Furnished								

ONE SPEED - TWO GEAR - POWERSHIFT (AIR)

885XBAHX-*3 (3)	423 l	Opp	73				Furnished								
885XGAHX-*3 (9)	329 l	Opp	94				Furnished								
885XJAHX-*3 (5)	279 l	Opp	111				Furnished								
885XMAHX-*3 (6)	238 l	Opp	130				Furnished								

ONE SPEED - FORWARD & REVERSE

348XFAHX-*5 (42)	200 l	Opp	94	99			Furnished	340XFAHX-*5 (42)	200 l	Opp	90	95	7-A-140(46)		Furnished
863XBAHX-*5	423 l	Opp	73	91			Furnished								

GEARED ADAPTERS

626XAHX-3AH	250 l	Eng			8-A-032		Furnished	626XAHX-3AH	250 l	Eng					Furnished
								630XAHX-3AH	250 l	Eng					Furnished
								645XAHX-3AH	250 l	Eng					Furnished

Continued on Next Page

† I = Intermittent Torque Only - De-rate Torque Rating 30% for Continuous Duty.

C = Continuous or Intermittent Torque - No need to De-Rate Torque Rating.

IMPORTANT: Refer to the back of this transmission section and read all notes associated with this application page. Some notes may affect the proper PTO selection.

CAUTION: Eaton Transmission Division has established a Maximum Torque Limit for the Transmission PTO Driver Gear. For all RT/RTO/RTLO transmissions the torque limit is 350 lb-ft [475 Nm] unless the transmission has been upgraded to a roller type input shaft bearing. Eaton part number 4301417, then 750 lb-ft [1017 Nm] torque becomes the Maximum limit. All torque limits on this application page reflect the 350 lb-ft [475 Nm] limit at the Transmission PTO Drive Gear. Refer to the Chelsea PTO Torque Limit Chart in the front of this section for complete torque limit information.

CAUTION: Do not use geared adapters with 442 A and C ratios.

(3) Input Gear Part No. 5-P-1100	(21) Input Gear Part No. 5-P-1510-11X	(27) Input Gear Part No. 5-P-1510-17X	(33) Input Gear Part No. 5-P-1510-4X	(42) Input Gear Part No. 5-P-581
(5) Input Gear Part No. 5-P-1102	(22) Input Gear Part No. 5-P-1510-12X	(28) Input Gear Part No. 5-P-1510-18X	(34) Input Gear Part No. 5-P-1510-5X	(46) Filler block furnished with PTO
(6) Input Gear Part No. 5-P-1103	(23) Input Gear Part No. 5-P-1510-13X	(29) Input Gear Part No. 5-P-1510-19X	(35) Input Gear Part No. 5-P-1510-6X	
(7) Input Gear Part No. 5-P-1104	(24) Input Gear Part No. 5-P-1510-14X	(30) Input Gear Part No. 5-P-1510-1X	(36) Input Gear Part No. 5-P-1510-7X	
(8) Input Gear Part No. 5-P-1105	(25) Input Gear Part No. 5-P-1510-15X	(31) Input Gear Part No. 5-P-1510-2X	(37) Input Gear Part No. 5-P-1510-8X	
(9) Input Gear Part No. 5-P-1135	(26) Input Gear Part No. 5-P-1510-16X	(32) Input Gear Part No. 5-P-1510-3X	(38) Input Gear Part No. 5-P-1510-9X	

CHELSEA®

EATON FULLER

FLR-59

RTO-14915
RTO-16915
RTX-14715
RTX-15715

REAR SIDE ONLY

TRANSMISSION GEAR DATA:

REAR 00-BOLT Opening

PITCH LINE TO APERTURE FACE:

CAUTION: Application Approval Required for PTO Output Shaft Speeds Above 2500 RPM

PTO Model	Torq	Dir Rot	Engine %		Filler Block	Adapter Assy	Stud Kit	PTO Model	Torq	Dir Rot	Engine %		Filler Block	Adapter Assy	Stud Kit
	I / C †		Fwd	Rev					I / C †		Fwd	Rev			

REAR MOUNT - "BD" MOUNTING OPTION

541-LBD-*.*	400 I	Eng	86				Furnished
541-MBD-*.*	350 I	Eng	111				Furnished
541-NBD-*.*	300 I	Eng	126				Furnished

† I = Intermittent Torque Only - De-rate Torque Rating 30% for Continuous Duty.

C = Continuous or Intermittent Torque - No need to De-Rate Torque Rating.

IMPORTANT: Refer to the back of this transmission section and read all notes associated with this application page. Some notes may affect the proper PTO selection.**CAUTION:** Eaton Transmission Division has established a Maximum Torque Limit for the Transmission PTO Driver Gear. For all RT/RTO/RTLO transmissions the torque limit is 350 lb-ft [475 Nm] unless the transmission has been upgraded to a roller type input shaft bearing, Eaton part number 4301417, then 750 lb-ft [1017 Nm] torque becomes the Maximum limit. All torque limits on this application page reflect the 350 lb-ft [475 Nm] limit at the Transmission PTO Drive Gear. Refer to the Chelsea PTO Torque Limit Chart in the front of this section for complete torque limit information.**CAUTION:** Do not use geared adapters with 442 A and C ratios.

Eaton Fuller

FLR-60

EATON FULLER

CHELSEA®

AT-1202

BOTTOM SIDE ONLY

TOP SIDE ONLY

TRANSMISSION GEAR DATA:

BOT 06-BOLT Opening Gear FORWARD of Centerline
30 Teeth - SPUR

PITCH LINE TO APERTURE FACE:

1.0500" (26.6700MM)

TRANSMISSION GEAR DATA:

TOP 08-BOLT Opening Gear FORWARD of Centerline
30 Teeth - SPUR

PITCH LINE TO APERTURE FACE:

0.7750" (19.6900MM)

CAUTION: Application Approval Required for PTO Output Shaft Speeds Above 2500 RPM

PTO Model	Torq I / C †	Dir Rot	Engine %		Filler Block	Adapter Assy	Stud Kit	PTO Model	Torq I / C †	Dir Rot	Engine %		Filler Block	Adapter Assy	Stud Kit
			Fwd	Rev							Fwd	Rev			
ONE SPEED - TWO GEAR - MECHANICAL SHIFT															
221XCABX-*3	250 I	Opp	64		7-A-032		Furnished	221ZCABX-*5	250 I	Opp	64		7-A-032(P)	328564X	Furnished
221XEABX-*3	250 I	Opp	71		7-A-032		Furnished	221ZCABX-*5	250 I	Opp	71		7-A-032(P)	328564X	Furnished
442XAABX-*3 (4)	250 I	Opp	53		7-A-032		Furnished	489XAABX-*5 (4)	250 I	Opp	53				Furnished
442XCABX-*3 (5)	250 I	Opp	68		7-A-032		Furnished	489XCABX-*5 (5)	250 I	Opp	68				Furnished
442XFABX-*3 (2)	250 I	Opp	84		7-A-032		Furnished	489XFABX-*5 (2)	250 I	Opp	84				Furnished
442XLABX-*3 (1)	250 I	Opp	108		7-A-032		Furnished	489XLABX-*5 (1)	250 I	Opp	108				Furnished
442XQABX-*3 (1)	225 I	Opp	117		7-A-032		Furnished	489XQABX-*5 (1)	225 I	Opp	117				Furnished
442XRABX-*3 (1)	225 I	Opp	135		7-A-032		Furnished	489XRABX-*5 (1)	225 I	Opp	135				Furnished
442XSABX-*3 (1)	200 I	Opp	161		7-A-032		Furnished	489XSABX-*5 (1)	200 I	Opp	161				Furnished
442XUABX-*3 (1)	195 I	Opp	192		7-A-032		Furnished	489XUABX-*5 (1)	195 I	Opp	192				Furnished
442XWABX-*3 (1)	175 I	Opp	225		7-A-032		Furnished	489XWABX-*5 (1)	175 I	Opp	225				Furnished
442XXABX-*3 (1)	140 I	Opp	267		7-A-032		Furnished	489XXABX-*5 (1)	140 I	Opp	267				Furnished
								880XBABX-*5 (3)	500 I	Opp	58				Furnished

ONE SPEED - FORWARD & REVERSE

								340SFABX-*5 (6)	200 I	Opp	76	80	7-A-032(P)	310778X	Furnished
								348XFABX-*5 (6)	200 I	Opp	76	80	8-A-093		Furnished
								863XBABX-*5	500 I	Opp	58	72			Furnished

GEARED ADAPTERS

626XABX-3AB	250 I	Eng			7-A-032		Furnished	628XABX-3AB	250 I	Eng					Furnished
630XABX-3AB	250 I	Eng			7-A-032		Furnished								
645XABX-3AB	250 I	Eng			7-A-032		Furnished								

† I = Intermittent Torque Only - De-rate Torque Rating 30% for Continuous Duty.

C = Continuous or Intermittent Torque - No need to De-Rate Torque Rating.

IMPORTANT: Refer to the back of this transmission section and read all notes associated with this application page.
Some notes may affect the proper PTO selection.**CAUTION:** Do not use geared adapters with 442 A and C ratios.

- (1) Input Gear Part No. 5-P-1001
 (2) Input Gear Part No. 5-P-1076
 (3) Input Gear Part No. 5-P-1099
 (4) Input Gear Part No. 5-P-1279
 (5) Input Gear Part No. 5-P-1286

- (6) Input Gear Part No. 5-P-579

CHELSEA®

EATON FULLER

FLR-64

RT-8608L

BOTTOM SIDE ONLY

RIGHT SIDE ONLY

TRANSMISSION GEAR DATA:

BOT 08-BOLT Opening Gear FORWARD of Centerline
47 Teeth - SPUR

PITCH LINE TO APERTURE FACE:

0.8050" (20.4500MM)

TRANSMISSION GEAR DATA:

R.S. 06-BOLT Opening Gear FORWARD of Centerline
45 Teeth - SPUR

PITCH LINE TO APERTURE FACE:

1.0850" (27.5600MM)

CAUTION: Application Approval Required for PTO Output Shaft Speeds Above 2500 RPM

PTO Model	Torq I / C †	Dir Rot	Engine %		Filler Block	Adapter Assy	Stud Kit	PTO Model	Torq I / C †	Dir Rot	Engine %		Filler Block	Adapter Assy	Stud Kit
			Fwd	Rev							Fwd	Rev			

ONE SPEED - TWO GEAR - MECHANICAL SHIFT

221ZCAHX-*3	250 I	Opp	50		7-A-032(P)(46)	328564X	Furnished	221XCAHX-*3	250 I	Opp	48		7-A-032(46)		Furnished
221ZEAHX-*3	250 I	Opp	58			328564X	Furnished	221XEAHX-*3	250 I	Opp	56				Furnished
489XAAHX-*5 (12)	250 I	Opp	44				Furnished	442XAAHX-*3 (12)	250 I	Opp	42				Furnished
489XCAHX-*5 (13)	250 I	Opp	57				Furnished	442XBAHX-*3 (18)	250 I	Eng	42			REQUIRED	Furnished
489XFAHX-*5 (2)	250 I	Opp	70				Furnished	442XCAHX-*3 (13)	250 I	Opp	54				Furnished
489XHAHX-*5 (15)	250 I	Opp	81				Furnished	442XFAHX-*3 (2)	250 I	Opp	67				Furnished
489XLAHX-*5 (1)	222 I	Opp	91				Furnished	442XHAHX-*3 (15)	250 I	Opp	78				Furnished
489XQAHX-*5 (1)	206 I	Opp	98				Furnished	442XLAHX-*3 (1)	233 I	Opp	87				Furnished
489XRAHX-*5 (1)	178 I	Opp	113				Furnished	442XQAHX-*3 (1)	216 I	Opp	94				Furnished
489XSAHX-*5 (1)	150 I	Opp	135				Furnished	442XRAHX-*3 (1)	187 I	Opp	108				Furnished
489XUAHX-*5 (1)	126 I	Opp	161				Furnished	442XSAHX-*3 (1)	156 I	Opp	129				Furnished
489XWAHX-*5 (1)	107 I	Opp	189				Furnished	442XUAHX-*3 (1)	132 I	Opp	154				Furnished
489XXAHX-*5 (1)	91 I	Opp	223				Furnished	442XWAHX-*3 (1)	112 I	Opp	181				Furnished
680XFAHX-*3 (10)	288 I	Opp	70				Furnished	442XXAHX-*3 (1)	94 I	Opp	214				Furnished
680XHAHX-*3 (20)	375 I	Opp	81				Furnished	660XFAHX-*3 (10)	301 I	Opp	67				Furnished
680XQAHX-*3 (11)	206 I	Opp	98				Furnished	660XHAHX-*3 (15)	260 I	Opp	78				Furnished
680XRAHX-*3 (19)	178 I	Opp	113				Furnished	660XQAHX-*3 (11)	216 I	Opp	94				Furnished
680XSAHX-*3 (14)	150 I	Opp	135				Furnished	660XRAHX-*3 (19)	187 I	Opp	108				Furnished
823XBAHX-*3 (40)	423 I	Opp	48				Furnished	660XSAHX-*3 (14)	156 I	Opp	129				Furnished
823XDAHX-*3 (45)	357 I	Opp	57				Furnished								
823XGAHX-*3 (43)	329 I	Opp	61				Furnished								
823XJAHX-*3 (41)	279 I	Opp	72				Furnished								
823XMAHX-*3 (39)	238 I	Opp	85				Furnished								
823XRAHX-*3 (44)	172 I	Opp	117				Furnished								
823XTKTX-*3 (17)	142 I	Opp	142		8-A-165(46)		Furnished								
880XBAHX-*3 (3)	423 I	Opp	48				Furnished								
880XDAHX-*3 (4)	357 I	Opp	57				Furnished								
880XGAHX-*3 (9)	329 I	Opp	61				Furnished								
880XJAHX-*3 (5)	279 I	Opp	72				Furnished								
880XMAHX-*3 (6)	238 I	Opp	85				Furnished								
880XQAHX-*3 (16)	203 I	Opp	99				Furnished								

Continued on Next Page

† I = Intermittent Torque Only - De-rate Torque Rating 30% for Continuous Duty.

C = Continuous or Intermittent Torque - No need to De-Rate Torque Rating.

IMPORTANT: Refer to the back of this transmission section and read all notes associated with this application page. Some notes may affect the proper PTO selection.

CAUTION: Eaton Transmission Division has established a Maximum Torque Limit for the Transmission PTO Driver Gear. For all RT/RTO/RTLO transmissions the torque limit is 350 lb-ft [475 Nm] unless the transmission has been upgraded to a roller type input shaft bearing, Eaton part number 4301417, then 750 lb-ft [1017 Nm] torque becomes the Maximum limit. All torque limits on this application page reflect the 350 lb-ft [475 Nm] limit at the Transmission PTO Drive Gear. Refer to the Chelsea PTO Torque Limit Chart in the front of this section for complete torque limit information.

CAUTION: Do not use geared adapters with 442 A and C ratios.

(1) Input Gear Part No. 5-P-1004	(6) Input Gear Part No. 5-P-1103	(13) Input Gear Part No. 5-P-1287	(18) Input Gear Part No. 5-P-1418	(41) Input Gear Part No. 5-P-325
(2) Input Gear Part No. 5-P-1077	(9) Input Gear Part No. 5-P-1135	(14) Input Gear Part No. 5-P-1322	(19) Input Gear Part No. 5-P-1441	(43) Input Gear Part No. 5-P-590
(3) Input Gear Part No. 5-P-1100	(10) Input Gear Part No. 5-P-1242	(15) Input Gear Part No. 5-P-1364	(20) Input Gear Part No. 5-P-1494	(44) Input Gear Part No. 5-P-721
(4) Input Gear Part No. 5-P-1101	(11) Input Gear Part No. 5-P-1246	(16) Input Gear Part No. 5-P-1385	(39) Input Gear Part No. 5-P-283	(45) Input Gear Part No. 5-P-971
(5) Input Gear Part No. 5-P-1102	(12) Input Gear Part No. 5-P-1280	(17) Input Gear Part No. 5-P-1395	(40) Input Gear Part No. 5-P-285	(46) Filler block furnished with PTO

FLR-64

EATON FULLER

CHELSEA®

RT-8608L

BOTTOM SIDE ONLY

RIGHT SIDE ONLY

TRANSMISSION GEAR DATA:

BOT 08-BOLT Opening Gear FORWARD of Centerline
47 Teeth - SPUR

PITCH LINE TO APERTURE FACE:

0.8050" (20.4500MM)

TRANSMISSION GEAR DATA:

R.S. 06-BOLT Opening Gear FORWARD of Centerline
45 Teeth - SPUR

PITCH LINE TO APERTURE FACE:

1.0850" (27.5600MM)

CAUTION: Application Approval Required for PTO Output Shaft Speeds Above 2500 RPM

PTO Model	Torq I / C †	Dir Rot	Engine %		Filler Block	Adapter Assy	Stud Kit	PTO Model	Torq I / C †	Dir Rot	Engine %		Filler Block	Adapter Assy	Stud Kit
			Fwd	Rev							Fwd	Rev			

ONE SPEED - TWO GEAR - MECHANICAL SHIFT

880XRAHX-*3 (7)	172 I	Opp	117				Furnished								
880XTAHX-*3 (8)	134 I	Opp	151				Furnished								

ONE SPEED - TWO GEAR POWERSHIFT (AIR OR HYDRAULIC)

272XAAJX-*3 (30)	300 C	Opp	39			328481X	Furnished	272XAAJX-*3 (30)	300 C	Opp	37				Furnished
282XBAJX-*3 (21)	300 C	Opp	48		8-A-032		Furnished	272XBAJX-*3 (31)	300 C	Opp	46				Furnished
282XCAJX-*3 (22)	300 C	Opp	58		8-A-032		Furnished	272XCAJX-*3 (32)	300 C	Opp	55				Furnished
282XDAJX-*3 (23)	293 C	Opp	69		8-A-032		Furnished	272XDAJX-*3 (33)	300 C	Opp	65				Furnished
282XGAJX-*3 (24)	246 C	Opp	82		8-A-032		Furnished	272XGAJX-*3 (34)	257 C	Opp	78				Furnished
282XKAJX-*3 (25)	220 C	Opp	92		8-A-032		Furnished	272XKAJX-*3 (35)	230 C	Opp	88				Furnished
282XMAJX-*3 (26)	197 C	Opp	102		8-A-032		Furnished	272XMAJX-*3 (36)	206 C	Opp	98				Furnished
282XPAJX-*3 (27)	176 C	Opp	114		8-A-032		Furnished	272XPAJX-*3 (37)	184 C	Opp	109				Furnished
282XSAJX-*3 (28)	158 C	Opp	128		8-A-032		Furnished	272XSAJX-*3 (38)	165 C	Opp	122				Furnished
282XTAJX-*3 (29)	141 C	Opp	143		8-A-032		Furnished								

ONE SPEED - TWO GEAR - POWERSHIFT (AIR)

885XBAHX-*3 (3)	423 I	Opp	48				Furnished								
885XGAHX-*3 (9)	329 I	Opp	61				Furnished								
885XJAHX-*3 (5)	279 I	Opp	72				Furnished								
885XMAHX-*3 (6)	238 I	Opp	85				Furnished								

ONE SPEED - FORWARD & REVERSE

348XFAHX-*5 (42)	200 I	Opp	61	64			Furnished	340XFAHX-*5 (42)	200 I	Opp	59	62	7-A-140(46)		Furnished
863XBAHX-*5	423 I	Opp	48	59			Furnished								

GEARED ADAPTERS

626XAHX-3AH	250 I	Eng			8-A-032		Furnished	626XAHX-3AH	250 I	Eng					Furnished
								630XAHX-3AH	250 I	Eng					Furnished
								645XAHX-3AH	250 I	Eng					Furnished

† I = Intermittent Torque Only - De-rate Torque Rating 30% for Continuous Duty.

C = Continuous or Intermittent Torque - No need to De-Rate Torque Rating.

IMPORTANT: Refer to the back of this transmission section and read all notes associated with this application page. Some notes may affect the proper PTO selection.

CAUTION: Eaton Transmission Division has established a Maximum Torque Limit for the Transmission PTO Driver Gear. For all RT/RT0/RTLO transmissions the torque limit is 350 lb-ft [475 Nm] unless the transmission has been upgraded to a roller type input shaft bearing. Eaton part number 4301417, then 750 lb-ft [1017 Nm] torque becomes the Maximum limit. All torque limits on this application page reflect the 350 lb-ft [475 Nm] limit at the Transmission PTO Drive Gear. Refer to the Chelsea PTO Torque Limit Chart in the front of this section for complete torque limit information.

CAUTION: Do not use geared adapters with 442 A and C ratios.

(3) Input Gear Part No. 5-P-1100	(21) Input Gear Part No. 5-P-1510-11X	(27) Input Gear Part No. 5-P-1510-17X	(33) Input Gear Part No. 5-P-1510-4X	(42) Input Gear Part No. 5-P-581
(5) Input Gear Part No. 5-P-1102	(22) Input Gear Part No. 5-P-1510-12X	(28) Input Gear Part No. 5-P-1510-18X	(34) Input Gear Part No. 5-P-1510-5X	(46) Filler block furnished with PTO
(6) Input Gear Part No. 5-P-1103	(23) Input Gear Part No. 5-P-1510-13X	(29) Input Gear Part No. 5-P-1510-19X	(35) Input Gear Part No. 5-P-1510-6X	
(7) Input Gear Part No. 5-P-1104	(24) Input Gear Part No. 5-P-1510-14X	(30) Input Gear Part No. 5-P-1510-1X	(36) Input Gear Part No. 5-P-1510-7X	
(8) Input Gear Part No. 5-P-1105	(25) Input Gear Part No. 5-P-1510-15X	(31) Input Gear Part No. 5-P-1510-2X	(37) Input Gear Part No. 5-P-1510-8X	
(9) Input Gear Part No. 5-P-1135	(26) Input Gear Part No. 5-P-1510-16X	(32) Input Gear Part No. 5-P-1510-3X	(38) Input Gear Part No. 5-P-1510-9X	

CHELSEA®

EATON FULLER

FLR-66

RT-6609A
RT-7608LL
RT-8609

BOTTOM SIDE ONLY

RIGHT SIDE ONLY

TRANSMISSION GEAR DATA:

BOT 08-BOLT Opening Gear FORWARD of Centerline
33 Teeth - SPUR

PITCH LINE TO APERTURE FACE:

0.8100" (20.5700MM)

TRANSMISSION GEAR DATA:

BOT 08-BOLT Opening Gear FORWARD of Centerline
33 Teeth - SPUR

PITCH LINE TO APERTURE FACE:

1.0900" (27.6900MM)

CAUTION: Application Approval Required for PTO Output Shaft Speeds Above 2500 RPM

PTO Model	Torq I / C †	Dir Rot	Engine %		Filler Block	Adapter Assy	Stud Kit	PTO Model	Torq I / C †	Dir Rot	Engine %		Filler Block	Adapter Assy	Stud Kit
			Fwd	Rev							Fwd	Rev			

ONE SPEED - TWO GEAR - MECHANICAL SHIFT

221XCAHX-*3	250 I	Opp	44		7-A-032(P)(46)	328481X	Furnished	221XCAHX-*3	250 I	Opp	44		7-A-032(46)		Furnished
221XEAHX-*3	250 I	Opp	51		7-A-032(P)	328481X	Furnished	221XEAHX-*3	250 I	Opp	51				Furnished
489XAAHX-*5 (12)	250 I	Opp	39				Furnished	442XAAHX-*3 (12)	250 I	Opp	39				Furnished
489XCAHX-*5 (13)	250 I	Opp	50				Furnished	442XBAHX-*3 (18)	250 I	Eng	39		REQUIRED		Furnished
489XFAHX-*5 (2)	250 I	Opp	61				Furnished	442XCAHX-*3 (13)	250 I	Opp	50				Furnished
489XHAHX-*5 (15)	250 I	Opp	71				Furnished	442XFAHX-*3 (2)	250 I	Opp	61				Furnished
489XLAHX-*5 (1)	250 I	Opp	79				Furnished	442XHAHX-*3 (15)	250 I	Opp	71				Furnished
489XQAHX-*5 (1)	225 I	Opp	85				Furnished	442XLAHX-*3 (1)	250 I	Opp	79				Furnished
489XRAHX-*5 (1)	225 I	Opp	99				Furnished	442XQAHX-*3 (1)	225 I	Opp	85				Furnished
489XSAHX-*5 (1)	200 I	Opp	118				Furnished	442XRAHX-*3 (1)	225 I	Opp	99				Furnished
489XUAHX-*5 (1)	195 I	Opp	140				Furnished	442XSAHX-*3 (1)	200 I	Opp	118				Furnished
489XWAHX-*5 (1)	175 I	Opp	165				Furnished	442XUAHX-*3 (1)	195 I	Opp	140				Furnished
489XXAHX-*5 (1)	140 I	Opp	195				Furnished	442XWAHX-*3 (1)	175 I	Opp	165				Furnished
680XFAHX-*3 (10)	375 I	Opp	61				Furnished	442XXAHX-*3 (1)	140 I	Opp	195				Furnished
680XHAHX-*3 (20)	375 I	Opp	71				Furnished	660XFAHX-*3 (10)	375 I	Opp	61				Furnished
680XQAHX-*3 (11)	375 I	Opp	85				Furnished	660XHAHX-*3 (15)	375 I	Opp	71				Furnished
680XRAHX-*3 (19)	350 I	Opp	99				Furnished	660XQAHX-*3 (11)	375 I	Opp	85				Furnished
680XSAHX-*3 (14)	325 I	Opp	118				Furnished	660XRAHX-*3 (19)	350 I	Opp	99				Furnished
823XBAHX-*3 (40)	500 I	Opp	42				Furnished	660XSAHX-*3 (14)	325 I	Opp	118				Furnished
823XDAHX-*3 (44)	500 I	Opp	50				Furnished								
823XGAHX-*3 (45)	500 I	Opp	54				Furnished								
823XJAHX-*3 (41)	500 I	Opp	63				Furnished								
823XMAHX-*3 (39)	500 I	Opp	74				Furnished								
823XRAHX-*3 (43)	400 I	Opp	103				Furnished								
823XTKTX-*3 (17)	500 I	Opp	124		8-A-165(46)		Furnished								
880XBAHX-*3 (3)	500 I	Opp	42				Furnished								
880XDAHX-*3 (4)	500 I	Opp	49				Furnished								
880XGAHX-*3 (9)	500 I	Opp	54				Furnished								
880XJAHX-*3 (5)	500 I	Opp	63				Furnished								
880XMAHX-*3 (6)	500 I	Opp	74				Furnished								
880XQAHX-*3 (16)	450 I	Opp	87				Furnished								

Continued on Next Page

† I = Intermittent Torque Only - De-rate Torque Rating 30% for Continuous Duty.

C = Continuous or Intermittent Torque - No need to De-Rate Torque Rating.

IMPORTANT: Refer to the back of this transmission section and read all notes associated with this application page.
Some notes may affect the proper PTO selection.

CAUTION: Do not use geared adapters with 442 A and C ratios.

- (1) Input Gear Part No. 5-P-1004
(2) Input Gear Part No. 5-P-1077
(3) Input Gear Part No. 5-P-1100
(4) Input Gear Part No. 5-P-1101
(5) Input Gear Part No. 5-P-1102

- (6) Input Gear Part No. 5-P-1103
(9) Input Gear Part No. 5-P-1135
(10) Input Gear Part No. 5-P-1242
(11) Input Gear Part No. 5-P-1246
(12) Input Gear Part No. 5-P-1280

- (13) Input Gear Part No. 5-P-1287
(14) Input Gear Part No. 5-P-1322
(15) Input Gear Part No. 5-P-1364
(16) Input Gear Part No. 5-P-1385
(17) Input Gear Part No. 5-P-1395

- (18) Input Gear Part No. 5-P-1418
(19) Input Gear Part No. 5-P-1441
(20) Input Gear Part No. 5-P-1494
(39) Input Gear Part No. 5-P-283
(40) Input Gear Part No. 5-P-285

- (41) Input Gear Part No. 5-P-325
(43) Input Gear Part No. 5-P-721
(44) Input Gear Part No. 5-P-971
(45) Input Gear Part No. 5-P-980
(46) Filler block furnished with PTO

FLR-66

EATON FULLER

CHELSEA®

RT-6609A
RT-7608LL
RT-6609

BOTTOM SIDE ONLY

RIGHT SIDE ONLY

TRANSMISSION GEAR DATA:

BOT 08-BOLT Opening Gear FORWARD of Centerline
33 Teeth - SPUR

PITCH LINE TO APERTURE FACE:

0.8100" (20.5700MM)

TRANSMISSION GEAR DATA:

R.S. 06-BOLT Opening Gear FORWARD of Centerline
33 Teeth - SPUR

PITCH LINE TO APERTURE FACE:

1.0900" (27.6900MM)

CAUTION: Application Approval Required for PTO Output Shaft Speeds Above 2500 RPM

PTO Model	Torq I / C †	Dir Rot	Engine %		Filler Block	Adapter Assy	Stud Kit	PTO Model	Torq I / C †	Dir Rot	Engine %		Filler Block	Adapter Assy	Stud Kit
			Fwd	Rev							Fwd	Rev			

ONE SPEED - TWO GEAR - MECHANICAL SHIFT

880XRAHX-*3 (7)	400 I	Opp	103				Furnished								
880XTAHX-*3 (8)	500 I	Opp	132				Furnished								

ONE SPEED - TWO GEAR POWERSHIFT (AIR OR HYDRAULIC)

272XAAJX-*3 (30)	300 C	Opp	34			328481X	Furnished	272XAAJX-*3 (30)	300 C	Opp	34				Furnished
282XBAJX-*3 (21)	300 C	Opp	42		8-A-032		Furnished	272XBAJX-*3 (31)	300 C	Opp	42				Furnished
282XCAJX-*3 (22)	300 C	Opp	51		8-A-032		Furnished	272XCAJX-*3 (32)	300 C	Opp	51				Furnished
282XDAJX-*3 (23)	293 C	Opp	60		8-A-032		Furnished	272XDAJX-*3 (33)	293 C	Opp	60				Furnished
282XGAJX-*3 (24)	246 C	Opp	72		8-A-032		Furnished	272XGAJX-*3 (34)	246 C	Opp	72				Furnished
282XKAJX-*3 (25)	220 C	Opp	80		8-A-032		Furnished	272XKAJX-*3 (35)	220 C	Opp	80				Furnished
282XMAJX-*3 (26)	197 C	Opp	90		8-A-032		Furnished	272XMAJX-*3 (36)	197 C	Opp	90				Furnished
282XPAJX-*3 (27)	176 C	Opp	100		8-A-032		Furnished	272XPAJX-*3 (37)	176 C	Opp	100				Furnished
282XSAJX-*3 (28)	158 C	Opp	112		8-A-032		Furnished	272XSAJX-*3 (38)	158 C	Opp	112				Furnished
282XTAJX-*3 (29)	141 C	Opp	126		8-A-032		Furnished								

ONE SPEED - POWERSHIFT LOW PROFILE (AIR OR HYDRAULIC)

272MCAJX-*3 (32)	300 C	Opp	51												Furnished
------------------	-------	-----	----	--	--	--	--	--	--	--	--	--	--	--	-----------

ONE SPEED - TWO GEAR - POWERSHIFT (AIR)

885XBAHX-*3 (3)	500 I	Opp	42				Furnished								
885XGAHX-*3 (9)	500 I	Opp	54				Furnished								
885XJAHX-*3 (5)	500 I	Opp	63				Furnished								
885XMAHX-*3 (6)	500 I	Opp	74				Furnished								

ONE SPEED - FORWARD & REVERSE

348ZFAHX-* (42)	200 I	Opp	54	56	8-A-032(46)		Furnished	340XFAHX-*5 (42)	200 I	Opp	54	56	7-A-140(46)		Furnished
863XBAHX-*5	500 I	Opp	42	52			Furnished								

GEARED ADAPTERS

628XAHX-3AH	250 I	Eng			8-A-032		Furnished	626XAHX-3AH	250 I	Eng					Furnished
								630XAHX-3AH	250 I	Eng					Furnished
								645XAHX-3AH	250 I	Eng					Furnished

† I = Intermittent Torque Only - De-rate Torque Rating 30% for Continuous Duty.

C = Continuous or Intermittent Torque - No need to De-Rate Torque Rating.

IMPORTANT: Refer to the back of this transmission section and read all notes associated with this application page. Some notes may affect the proper PTO selection.

CAUTION: Do not use geared adapters with 442 A and C ratios.

(3) Input Gear Part No. 5-P-1100	(21) Input Gear Part No. 5-P-1510-11X	(27) Input Gear Part No. 5-P-1510-17X	(33) Input Gear Part No. 5-P-1510-4X	(42) Input Gear Part No. 5-P-581
(5) Input Gear Part No. 5-P-1102	(22) Input Gear Part No. 5-P-1510-12X	(28) Input Gear Part No. 5-P-1510-18X	(34) Input Gear Part No. 5-P-1510-5X	(46) Filler block furnished with PTO
(6) Input Gear Part No. 5-P-1103	(23) Input Gear Part No. 5-P-1510-13X	(29) Input Gear Part No. 5-P-1510-19X	(35) Input Gear Part No. 5-P-1510-6X	
(7) Input Gear Part No. 5-P-1104	(24) Input Gear Part No. 5-P-1510-14X	(30) Input Gear Part No. 5-P-1510-1X	(36) Input Gear Part No. 5-P-1510-7X	
(8) Input Gear Part No. 5-P-1105	(25) Input Gear Part No. 5-P-1510-15X	(31) Input Gear Part No. 5-P-1510-2X	(37) Input Gear Part No. 5-P-1510-8X	
(9) Input Gear Part No. 5-P-1135	(26) Input Gear Part No. 5-P-1510-16X	(32) Input Gear Part No. 5-P-1510-3X	(38) Input Gear Part No. 5-P-1510-9X	

CHELSEA®

EATON FULLER

FLR-67

FS-6106A
FS-7206A
FS-8206A
FS-8406A

LEFT SIDE ONLY

RIGHT SIDE ONLY

TRANSMISSION GEAR DATA:

L.S. 06-BOLT Opening Gear FORWARD of Centerline
50 Teeth - R.H. HELIX

PITCH LINE TO APERTURE FACE:

1.1800" (29.9720MM)

TRANSMISSION GEAR DATA:

R.S. 08-BOLT Opening Gear FORWARD of Centerline
50 Teeth - R.H. HELIX

PITCH LINE TO APERTURE FACE:

0.9100" (23.1140MM)

CAUTION: Application Approval Required for PTO Output Shaft Speeds Above 2500 RPM

PTO Model	Torq I / C †	Dir Rot	Engine %		Filler Block	Adapter Assy	Stud Kit	PTO Model	Torq I / C †	Dir Rot	Engine %		Filler Block	Adapter Assy	Stud Kit
			Fwd	Rev							Fwd	Rev			
ONE SPEED - TWO GEAR - MECHANICAL SHIFT															
442XFDUX-*5 (2)	250 I	Opp	46				Furnished	489XFDUX-*3 (2)	250 I	Opp	46				Furnished
442XLDUX-*5 (1)	250 I	Opp	60				Furnished	489XLDUX-*3 (1)	250 I	Opp	60				Furnished
442XQDUX-*5 (1)	225 I	Opp	64				Furnished	489XQDUX-*3 (1)	225 I	Opp	64				Furnished
442XRDUX-*5 (1)	225 I	Opp	74				Furnished	489XRDUX-*3 (1)	225 I	Opp	74				Furnished
442XSDUX-*5 (1)	200 I	Opp	89				Furnished	489XSDUX-*3 (1)	200 I	Opp	89				Furnished
442XUDUX-*5 (1)	195 I	Opp	106				Furnished	489XUDUX-*3 (1)	195 I	Opp	106				Furnished
442XWDUX-*5 (1)	175 I	Opp	124				Furnished	489XWDUX-*3 (1)	175 I	Opp	124				Furnished
442XXDUX-*5 (1)	140 I	Opp	147				Furnished	489XXDUX-*3 (1)	140 I	Opp	147				Furnished
								880XMDUX-*3 (3)	500 I	Opp	58				Furnished
								880XRDUX-*3 (5)	400 I	Opp	81				Furnished
								880XTDUX-*3 (4)	350 I	Opp	108				Furnished
ONE SPEED - FORWARD & REVERSE															
340XFDUX-*5 (6)	200 I	Opp	42	44	7-A-140(7)		Furnished	340XFDUX-*3 (6)	200 I	Opp	42	44	7-A-140(7)	328481X	Furnished
								348XFDUX-*3 (6)	200 I	Opp	42	44			Furnished
GEARED ADAPTERS															
626XDUX-4HH	250 I	Eng					Furnished	628XDUX-3HH	250 I	Eng					Furnished
630XDUX-4HH	250 I	Eng					Furnished								
645XDUX-4HH	250 I	Eng					Furnished								

† I = Intermittent Torque Only - De-rate Torque Rating 30% for Continuous Duty.

C = Continuous or Intermittent Torque - No need to De-Rate Torque Rating.

IMPORTANT: Refer to the back of this transmission section and read all notes associated with this application page. Some notes may affect the proper PTO selection.

(1) Input Gear Part No. 5-P-1050
 (2) Input Gear Part No. 5-P-1088
 (3) Input Gear Part No. 5-P-1130
 (4) Input Gear Part No. 5-P-1131
 (5) Input Gear Part No. 5-P-1176

(6) Input Gear Part No. 5-P-883
 (7) Filler block furnished with PTO

FLR-68

EATON FULLER

CHELSEA®

FS-5306A
FS-5406A
FS-6206A
FS-6306A
FS-6406A
FS-6206
FS-6306
FS-6406

LEFT SIDE ONLY

RIGHT SIDE ONLY

TRANSMISSION GEAR DATA:

L.S. 06-BOLT Opening Gear FORWARD of Centerline
38 Teeth - R.H. HELIX

PITCH LINE TO APERTURE FACE:

1.0850" (27.5590MM)

TRANSMISSION GEAR DATA:

R.S. 06-BOLT Opening Gear FORWARD of Centerline
38 Teeth - R.H. HELIX

PITCH LINE TO APERTURE FACE:

1.0850" (27.5590MM)

CAUTION: Application Approval Required for PTO Output Shaft Speeds Above 2500 RPM

PTO Model	Torq l / C †	Dir Rot	Engine %		Filler Block	Adapter Assy	Stud Kit	PTO Model	Torq l / C †	Dir Rot	Engine %		Filler Block	Adapter Assy	Stud Kit
			Fwd	Rev							Fwd	Rev			

ONE SPEED - TWO GEAR - MECHANICAL SHIFT

442XAESX-*5 (3)	250 l	Opp	32		7-A-062		Furnished	442XAESX-*3 (3)	250 l	Opp	32		7-A-062		Furnished
442XCESX-*5 (4)	250 l	Opp	41		7-A-062		Furnished	442XCESX-*3 (4)	250 l	Opp	41		7-A-062		Furnished
442XFESX-*5 (2)	250 l	Opp	51		7-A-062		Furnished	442XFESX-*3 (2)	250 l	Opp	51		7-A-062		Furnished
442XLESX-*5 (1)	250 l	Opp	66		7-A-062		Furnished	442XLESX-*3 (1)	250 l	Opp	66		7-A-062		Furnished
442XQESX-*5 (1)	225 l	Opp	71		7-A-062		Furnished	442XQESX-*3 (1)	225 l	Opp	71		7-A-062		Furnished
442XRESX-*5 (1)	225 l	Opp	82		7-A-062		Furnished	442XRESX-*3 (1)	225 l	Opp	82		7-A-062		Furnished
442XSSESX-*5 (1)	200 l	Opp	98		7-A-062		Furnished	442XSSESX-*3 (1)	200 l	Opp	98		7-A-062		Furnished
442XUESX-*5 (1)	195 l	Opp	117		7-A-062		Furnished	442XUESX-*3 (1)	195 l	Opp	117		7-A-062		Furnished
442XWSESX-*5 (1)	175 l	Opp	138		7-A-062		Furnished	442XWSESX-*3 (1)	175 l	Opp	138		7-A-062		Furnished
442XXSESX-*5 (1)	140 l	Opp	163		7-A-062		Furnished	442XXSESX-*3 (1)	140 l	Opp	163		7-A-062		Furnished

ONE SPEED - TWO GEAR POWERSHIFT (AIR OR HYDRAULIC)

272XAESX-*5 (5)	300 C	Opp	31				Furnished	272XAESX-*3 (5)	300 C	Opp	31				Furnished
272XBESX-*5 (6)	300 C	Opp	38				Furnished	272XBESX-*3 (6)	300 C	Opp	38				Furnished
272XCESX-*5 (7)	300 C	Opp	46				Furnished	272XCESX-*3 (7)	300 C	Opp	46				Furnished
272XDESX-*5 (8)	300 C	Opp	55				Furnished	272XDESX-*3 (8)	300 C	Opp	55				Furnished
272XGESX-*5 (9)	300 C	Opp	65				Furnished	272XGESX-*3 (9)	300 C	Opp	65				Furnished
272XKESX-*5 (10)	300 C	Opp	73				Furnished	272XKESX-*3 (10)	300 C	Opp	73				Furnished
272XMESX-*5 (11)	300 C	Opp	82				Furnished	272XMESX-*3 (11)	300 C	Opp	82				Furnished
272XPESX-*5 (12)	286 C	Opp	91				Furnished	272XPESX-*3 (12)	286 C	Opp	91				Furnished
272XSESX-*5 (13)	256 C	Opp	102				Furnished	272XSESX-*3 (13)	256 C	Opp	102				Furnished

ONE SPEED - POWERSHIFT LOW PROFILE (AIR OR HYDRAULIC)

272MAESX-*5 (5)	300 C	Opp	31				Furnished	272MAESX-*3 (5)	300 C	Opp	31				Furnished
272MBESX-*5 (6)	300 C	Opp	38				Furnished	272MBESX-*3 (6)	300 C	Opp	38				Furnished
272MCESX-*5 (7)	300 C	Opp	46				Furnished	272MCESX-*3 (7)	300 C	Opp	46				Furnished
272MDESX-*5 (8)	300 C	Opp	55				Furnished	272MDESX-*3 (8)	300 C	Opp	55				Furnished
272MGESX-*5 (9)	300 C	Opp	65				Furnished	272MGESX-*3 (9)	300 C	Opp	65				Furnished
272MKESX-*5 (10)	300 C	Opp	73				Furnished	272MKESX-*3 (10)	300 C	Opp	73				Furnished
272MMESX-*5 (11)	300 C	Opp	82				Furnished	272MMESX-*3 (11)	300 C	Opp	82				Furnished
272MPESX-*5 (12)	286 C	Opp	91				Furnished	272MPESX-*3 (12)	286 C	Opp	91				Furnished
272MSESX-*5 (13)	256 C	Opp	102				Furnished	272MSESX-*3 (13)	256 C	Opp	102				Furnished

Continued on Next Page

† I = Intermittent Torque Only - De-rate Torque Rating 30% for Continuous Duty.

C = Continuous or Intermittent Torque - No need to De-Rate Torque Rating.

IMPORTANT: Refer to the back of this transmission section and read all notes associated with this application page. Some notes may affect the proper PTO selection.**CAUTION:** Do not use geared adapters with 442 A and C ratios.

- (1) Input Gear Part No. 5-P-1059 (6) Input Gear Part No. 5-P-1512-2X (11) Input Gear Part No. 5-P-1512-7X
 (2) Input Gear Part No. 5-P-1092 (7) Input Gear Part No. 5-P-1512-3X (12) Input Gear Part No. 5-P-1512-8X
 (3) Input Gear Part No. 5-P-1285 (8) Input Gear Part No. 5-P-1512-4X (13) Input Gear Part No. 5-P-1512-9X
 (4) Input Gear Part No. 5-P-1292 (9) Input Gear Part No. 5-P-1512-5X
 (5) Input Gear Part No. 5-P-1512-1X (10) Input Gear Part No. 5-P-1512-6X

CHELSEA®

EATON FULLER

FLR-68

FS-5306A
FS-5406A
FS-6206A
FS-6306A
FS-6406A
FS-6206
FS-6306
FS-6406

LEFT SIDE ONLY

RIGHT SIDE ONLY

TRANSMISSION GEAR DATA:

L.S. 06-BOLT Opening Gear FORWARD of Centerline
38 Teeth - R.H. HELIX

PITCH LINE TO APERTURE FACE:

1.0850" (27.5590MM)

TRANSMISSION GEAR DATA:

R.S. 06-BOLT Opening Gear FORWARD of Centerline
38 Teeth - R.H. HELIX

PITCH LINE TO APERTURE FACE:

1.0850" (27.5590MM)

CAUTION: Application Approval Required for PTO Output Shaft Speeds Above 2500 RPM

PTO Model	Torq	Dir Rot	Engine %		Filler Block	Adapter Assy	Stud Kit	PTO Model	Torq	Dir Rot	Engine %		Filler Block	Adapter Assy	Stud Kit
	I / C †		Fwd	Rev					I / C †		Fwd	Rev			
ONE SPEED - FORWARD & REVERSE															
340XFESX-*5 (14)	200 I	Opp	47	49	7-A-140(15) 7-A-093		328170-76X	340XFESX-*5 (14)	200 I	Opp	47	49	7-A-140(15) 7-A-093		328170-76X
352XSESX-*5 (1)	140 I	Opp	99	129	7-A-062		Furnished	352XSESX-*3 (1)	140 I	Opp	99	129	7-A-062		Furnished
GEARED ADAPTERS															
626XESX-4HL	250 I	Eng			7-A-062		Furnished	626XESX-3HL	250 I	Eng			7-A-062		Furnished
630XESX-4HL	250 I	Eng			7-A-062		Furnished	630XESX-3HL	250 I	Eng			7-A-062		Furnished
645XESX-4HL	250 I	Eng			7-A-062		Furnished	645XESX-3HL	250 I	Eng			7-A-062		Furnished

Continued on Next Page

† I = Intermittent Torque Only - De-rate Torque Rating 30% for Continuous Duty.

C = Continuous or Intermittent Torque - No need to De-Rate Torque Rating.

IMPORTANT: Refer to the back of this transmission section and read all notes associated with this application page.
Some notes may affect the proper PTO selection.

CAUTION: Do not use geared adapters with 442 A and C ratios.

(1) Input Gear Part No. 5-P-1059
(14) Input Gear Part No. 5-P-884
(15) Filler block furnished with PTO

FLR-68

EATON FULLER

CHELSEA®

FS-5306A
FS-5406A
FS-6206A
FS-6306A
FS-6406A
FS-6206
FS-6306
FS-6406

REAR SIDE ONLY

TRANSMISSION GEAR DATA:

REAR 04-BOLT Opening

PITCH LINE TO APERTURE FACE:

CAUTION: Application Approval Required for PTO Output Shaft Speeds Above 2500 RPM

PTO Model	Torq	Dir Rot	Engine %		Filler Block	Adapter Assy	Stud Kit	PTO Model	Torq	Dir Rot	Engine %		Filler Block	Adapter Assy	Stud Kit
	I / C †		Fwd	Rev					I / C †		Fwd	Rev			

REAR MOUNT - MECHANICAL SHIFT (6 SPEED TRANSMISSIONS)

511XRALW-**-*

590 C Opp 52

Furnished

† I = Intermittent Torque Only - De-rate Torque Rating 30% for Continuous Duty.

C = Continuous or Intermittent Torque - No need to De-Rate Torque Rating.

IMPORTANT: Refer to the back of this transmission section and read all notes associated with this application page. Some notes may affect the proper PTO selection.

CAUTION: Do not use geared adapters with 442 A and C ratios.

Eaton Fuller

CHELSEA®

EATON FULLER

FLR-69

FS-6205A
FS-6305A

LEFT SIDE ONLY

RIGHT SIDE ONLY

TRANSMISSION GEAR DATA:

L.S. 06-BOLT Opening Gear FORWARD of Centerline
39 Teeth - R.H. HELIX

PITCH LINE TO APERTURE FACE:

1.0000" (25.4000MM)

TRANSMISSION GEAR DATA:

R.S. 06-BOLT Opening Gear FORWARD of Centerline
39 Teeth - R.H. HELIX

PITCH LINE TO APERTURE FACE:

1.0000" (25.4000MM)

CAUTION: Application Approval Required for PTO Output Shaft Speeds Above 2500 RPM

PTO Model	Torq I / C †	Dir Rot	Engine %		Filler Block	Adapter Assy	Stud Kit	PTO Model	Torq I / C †	Dir Rot	Engine %		Filler Block	Adapter Assy	Stud Kit
			Fwd	Rev							Fwd	Rev			

ONE SPEED - TWO GEAR - MECHANICAL SHIFT

442KAESX-*5 (3)	250 I	Opp	30		7-A-165		7170-3X	442KAESX-*3 (3)	250 I	Opp	30		7-A-165		7170-3X
442KCESX-*5 (4)	250 I	Opp	39		7-A-165		7170-3X	442KCESX-*3 (4)	250 I	Opp	39		7-A-165		7170-3X
442KFESX-*5 (2)	250 I	Opp	48		7-A-165		7170-3X	442KFESX-*3 (2)	250 I	Opp	48		7-A-165		7170-3X
442KLESX-*5 (1)	250 I	Opp	62		7-A-165		7170-3X	442KLESX-*3 (1)	250 I	Opp	62		7-A-165		7170-3X
442KQESX-*5 (1)	225 I	Opp	67		7-A-165		7170-3X	442KQESX-*3 (1)	225 I	Opp	67		7-A-165		7170-3X
447KQESX-*5 (10)	225 I	Opp	67		7-A-165		7170-3X	447KQESX-*3 (10)	225 I	Opp	67		7-A-165		7170-3X
447KSESX-*5 (11)	200 I	Opp	93		7-A-165		7170-3X	447KSESX-*3 (11)	200 I	Opp	93		7-A-165		7170-3X
447KUESX-*5 (12)	195 I	Opp	110		7-A-165		7170-3X	447KUESX-*3 (12)	195 I	Opp	110		7-A-165		7170-3X
447KWESX-*5 (13)	175 I	Opp	130		7-A-165		7170-3X	447KWESX-*3 (13)	175 I	Opp	130		7-A-165		7170-3X

ONE SPEED - TWO GEAR POWERSHIFT (AIR OR HYDRAULIC)

272XAESX-*5 (5)	300 C	Opp	29		7-A-062		Furnished	272XAESX-*3 (5)	300 C	Opp	29		7-A-062		Furnished
272XBESX-*5 (6)	300 C	Opp	36		7-A-062		Furnished	272XBESX-*3 (6)	300 C	Opp	36		7-A-062		Furnished
272XCESX-*5 (7)	300 C	Opp	43		7-A-062		Furnished	272XCESX-*3 (7)	300 C	Opp	43		7-A-062		Furnished
272XDESX-*5 (8)	300 C	Opp	52		7-A-062		Furnished	272XDESX-*3 (8)	300 C	Opp	52		7-A-062		Furnished
272XGESX-*5 (9)	300 C	Opp	61		7-A-062		Furnished	272XGESX-*3 (9)	300 C	Opp	61		7-A-062		Furnished

ONE SPEED - POWERSHIFT LOW PROFILE (AIR OR HYDRAULIC)

272MAESX-*5 (5)	300 C	Opp	29		7-A-062		Furnished	272MAESX-*3 (5)	300 C	Opp	29		7-A-062		Furnished
272MBESX-*5 (6)	300 C	Opp	36		7-A-062		Furnished	272MBESX-*3 (6)	300 C	Opp	36		7-A-062		Furnished
272MCESX-*5 (7)	300 C	Opp	43		7-A-062		Furnished	272MCESX-*3 (7)	300 C	Opp	43		7-A-062		Furnished
272MDESX-*5 (8)	300 C	Opp	52		7-A-062		Furnished	272MDESX-*3 (8)	300 C	Opp	52		7-A-062		Furnished
272MGESX-*5 (9)	300 C	Opp	61		7-A-062		Furnished	272MGESX-*3 (9)	300 C	Opp	61		7-A-062		Furnished

ONE SPEED - FORWARD & REVERSE

340XFESX-*5 (14)	200 I	Opp	44	46	7-A-140(15) 7-A-200		328170-76X	340XFESX-*5 (14)	200 I	Opp	44	46	7-A-140(15) 7-A-200		328170-76X
------------------	-------	-----	----	----	------------------------	--	------------	------------------	-------	-----	----	----	------------------------	--	------------

† I = Intermittent Torque Only - De-rate Torque Rating 30% for Continuous Duty.

C = Continuous or Intermittent Torque - No need to De-Rate Torque Rating.

IMPORTANT: Refer to the back of this transmission section and read all notes associated with this application page.
Some notes may affect the proper PTO selection.

CAUTION: Do not use geared adapters with 442 A and C ratios.

- | | | |
|-------------------------------------|-------------------------------------|--------------------------------------|
| (1) Input Gear Part No. 5-P-1059 | (6) Input Gear Part No. 5-P-1512-2X | (11) Input Gear Part No. 5-P-870 |
| (2) Input Gear Part No. 5-P-1092 | (7) Input Gear Part No. 5-P-1512-3X | (12) Input Gear Part No. 5-P-871 |
| (3) Input Gear Part No. 5-P-1285 | (8) Input Gear Part No. 5-P-1512-4X | (13) Input Gear Part No. 5-P-872 |
| (4) Input Gear Part No. 5-P-1292 | (9) Input Gear Part No. 5-P-1512-5X | (14) Input Gear Part No. 5-P-884 |
| (5) Input Gear Part No. 5-P-1512-1X | (10) Input Gear Part No. 5-P-869 | (15) Filler block furnished with PTO |

FLR-70

EATON FULLER

CHELSEA®

FS-6205B
FS-6305B

LEFT SIDE ONLY

RIGHT SIDE ONLY

TRANSMISSION GEAR DATA:

L.S. 06-BOLT Opening Gear FORWARD of Centerline
41 Teeth - R.H. HELIX

PITCH LINE TO APERTURE FACE:

0.8860" (22.5044MM)

TRANSMISSION GEAR DATA:

R.S. 06-BOLT Opening Gear FORWARD of Centerline
41 Teeth - R.H. HELIX

PITCH LINE TO APERTURE FACE:

0.8860" (22.5044MM)

CAUTION: Application Approval Required for PTO Output Shaft Speeds Above 2500 RPM

PTO Model	Torq	Dir Rot	Engine %		Filler Block	Adapter Assy	Stud Kit	PTO Model	Torq	Dir Rot	Engine %		Filler Block	Adapter Assy	Stud Kit
	I / C †		Fwd	Rev					I / C †		Fwd	Rev			
ONE SPEED - TWO GEAR - MECHANICAL SHIFT															
447XQETX-*5 (1)	200 I	Opp	82				Furnished	447XQETX-*3 (1)	200 I	Opp	82				Furnished
447XSETX-*5 (2)	200 I	Opp	113				Furnished	447XSETX-*3 (2)	200 I	Opp	113				Furnished
447XUETX-*5 (3)	195 I	Opp	134				Furnished	447XUETX-*3 (3)	195 I	Opp	134				Furnished
447XWETX-*5 (4)	175 I	Opp	158				Furnished	447XWETX-*3 (4)	175 I	Opp	158				Furnished
ONE SPEED - FORWARD & REVERSE															
340XFETX-*5 (5)	200 I	Opp	44	46	7-A-140(6) 7-A-300		7170-3X	340XFETX-*5 (5)	200 I	Opp	44	46	7-A-140(6) 7-A-300		7170-3X

† I = Intermittent Torque Only - De-rate Torque Rating 30% for Continuous Duty.

C = Continuous or Intermittent Torque - No need to De-Rate Torque Rating.

IMPORTANT: Refer to the back of this transmission section and read all notes associated with this application page. Some notes may affect the proper PTO selection.

- (1) Input Gear Part No. 5-P-865
- (2) Input Gear Part No. 5-P-866
- (3) Input Gear Part No. 5-P-867
- (4) Input Gear Part No. 5-P-868
- (5) Input Gear Part No. 5-P-948

(6) Filler block furnished with PTO

CHELSEA®

EATON FULLER

FLR-75

T-14607A
T-14607B

LEFT SIDE ONLY

RIGHT SIDE ONLY

TRANSMISSION GEAR DATA:

L.S. 08-BOLT Opening Gear FORWARD of Centerline
78 Teeth - SPUR

PITCH LINE TO APERTURE FACE:

0.8650" (21.9710MM)

TRANSMISSION GEAR DATA:

R.S. 06-BOLT Opening Gear FORWARD of Centerline
78 Teeth - SPUR

PITCH LINE TO APERTURE FACE:

0.9740" (24.7400MM)

CAUTION: Application Approval Required for PTO Output Shaft Speeds Above 2500 RPM

PTO Model	Torq	Dir Rot	Engine %		Filler Block	Adapter Assy	Stud Kit	PTO Model	Torq	Dir Rot	Engine %		Filler Block	Adapter Assy	Stud Kit
	I / C †		Fwd	Rev					I / C †		Fwd	Rev			

ONE SPEED - TWO GEAR - MECHANICAL SHIFT

489XFEVX-*5 (2)	250 I	Opp	57		8-A-062		Furnished	442KFEVX-*5 (2)	250 I	Opp	57		7-A-187		7170-3X
489XLEVX-*5 (1)	250 I	Opp	73		8-A-062		Furnished	442KLEVX-*5 (1)	250 I	Opp	73		7-A-187		7170-3X
489XQEVX-*5 (1)	225 I	Opp	79		8-A-062		Furnished	442KQEVX-*5 (1)	225 I	Opp	79		7-A-187		7170-3X
489XREVX-*5 (1)	225 I	Opp	92		8-A-062		Furnished	442KREVX-*5 (1)	225 I	Opp	92		7-A-187		7170-3X
489XSEVX-*5 (1)	200 I	Opp	109		8-A-062		Furnished	442KSEVX-*5 (1)	200 I	Opp	109		7-A-187		7170-3X
489XUEVX-*5 (1)	195 I	Opp	130		8-A-062		Furnished	442KUEVX-*5 (1)	195 I	Opp	130		7-A-187		7170-3X
489XWEVX-*5 (1)	175 I	Opp	153		8-A-062		Furnished	442KWEVX-*5 (1)	175 I	Opp	153		7-A-187		7170-3X
489XSEVX-*5 (1)	140 I	Opp	181		8-A-062		Furnished	442KSEVX-*5 (1)	140 I	Opp	181		7-A-187		7170-3X

GEARED ADAPTERS

628XEVX-4EV	250 I	Eng			8-A-062		Furnished	626KEVX-3EV	250 I	Eng			7-A-187		7170-3X
								630KEVX-3EV	250 I	Eng			7-A-187		7170-3X
								645KEVX-3EV	250 I	Eng			7-A-187		7170-3X

† I = Intermittent Torque Only - De-rate Torque Rating 30% for Continuous Duty.

C = Continuous or Intermittent Torque - No need to De-Rate Torque Rating.

IMPORTANT: Refer to the back of this transmission section and read all notes associated with this application page. Some notes may affect the proper PTO selection.

(1) Input Gear Part No. 5-P-1060
(2) Input Gear Part No. 5-P-1094

FLR-77

EATON FULLER

CHELSEA®

TX-14607B

LEFT SIDE ONLY

RIGHT SIDE ONLY

TRANSMISSION GEAR DATA:

L.S. 08-BOLT Opening Gear REAR of Centerline
78 Teeth - SPUR

PITCH LINE TO APERTURE FACE:

0.8650" (21.9710MM)

TRANSMISSION GEAR DATA:

R.S. 06-BOLT Opening Gear REAR of Centerline
78 Teeth - SPUR

PITCH LINE TO APERTURE FACE:

0.9740" (24.7400MM)

CAUTION: Application Approval Required for PTO Output Shaft Speeds Above 2500 RPM

PTO Model	Torq I / C †	Dir Rot	Engine %		Filler Block	Adapter Assy	Stud Kit	PTO Model	Torq I / C †	Dir Rot	Engine %		Filler Block	Adapter Assy	Stud Kit
			Fwd	Rev							Fwd	Rev			
ONE SPEED - TWO GEAR - MECHANICAL SHIFT															
489XFEVX-*4 (2)	250 I	Opp	76		8-A-032		Furnished	442KFEVX-*4 (2)	250 I	Opp	76		7-A-187		7170-3X
489XLEVX-*4 (1)	250 I	Opp	98		8-A-032		Furnished	442KLEVX-*4 (1)	250 I	Opp	98		7-A-187		7170-3X
489XQEVX-*4 (1)	225 I	Opp	106		8-A-032		Furnished	442KQEVX-*4 (1)	225 I	Opp	106		7-A-187		7170-3X
489XREVX-*4 (1)	225 I	Opp	122		8-A-032		Furnished	442KREVX-*4 (1)	225 I	Opp	122		7-A-187		7170-3X
								447KQEVX-*4 (3)	225 I	Opp	106		7-A-187		7171-3X
								447KREVX-*4 (7)	225 I	Opp	122		7-A-187		7170-3X
								447KSEVX-*4 (4)	200 I	Opp	146		7-A-187		7170-3X
								447KUEVX-*4 (5)	195 I	Opp	174		7-A-187		7170-3X
								447KWEVX-*4 (6)	175 I	Opp	204		7-A-187		7170-3X
GEARED ADAPTERS															
628XEVX-3EV	250 I	Eng			8-A-062		Furnished	626KEVX-4EV	250 I	Eng			7-A-187		7170-3X
								630KEVX-4EV	250 I	Eng			7-A-187		7170-3X
								645KEVX-4EV	250 I	Eng			7-A-187		7170-3X

† I = Intermittent Torque Only - De-rate Torque Rating 30% for Continuous Duty.

C = Continuous or Intermittent Torque - No need to De-Rate Torque Rating.

IMPORTANT: Refer to the back of this transmission section and read all notes associated with this application page. Some notes may affect the proper PTO selection.

(1) Input Gear Part No. 5-P-1060
 (2) Input Gear Part No. 5-P-1094
 (3) Input Gear Part No. 5-P-1205
 (4) Input Gear Part No. 5-P-1206
 (5) Input Gear Part No. 5-P-1207

(6) Input Gear Part No. 5-P-1208
 (7) Input Gear Part No. 5-P-1219

CHELSEA®

EATON FULLER

FLR-78

FS-4205A

LEFT SIDE ONLY

RIGHT SIDE ONLY

TRANSMISSION GEAR DATA:

L.S. 06-BOLT Opening Gear FORWARD of Centerline
28 Teeth - R.H. HELIX

PITCH LINE TO APERTURE FACE:

1.1469" (29.1313MM)

TRANSMISSION GEAR DATA:

R.S. 06-BOLT Opening Gear FORWARD of Centerline
28 Teeth - R.H. HELIX

PITCH LINE TO APERTURE FACE:

1.1469" (29.1313MM)

CAUTION: Application Approval Required for PTO Output Shaft Speeds Above 2500 RPM

PTO Model	Torq	Dir Rot	Engine %		Filler Block	Adapter Assy	Stud Kit	PTO Model	Torq	Dir Rot	Engine %		Filler Block	Adapter Assy	Stud Kit
	I / C †		Fwd	Rev					I / C †		Fwd	Rev			

ONE SPEED - TWO GEAR - MECHANICAL SHIFT

442XFEWX-*5 (2)	250 I	Opp	36				Furnished	442XFEWX-*3 (2)	250 I	Opp	36				Furnished
442XLEWX-*5 (1)	250 I	Opp	47				Furnished	442XLEWX-*3 (1)	250 I	Opp	47				Furnished
442XQEWX-*5 (1)	225 I	Opp	51				Furnished	442XQEWX-*3 (1)	225 I	Opp	51				Furnished
442XREWX-*5 (1)	225 I	Opp	59				Furnished	442XREWX-*3 (1)	225 I	Opp	59				Furnished
442XSEWX-*5 (1)	200 I	Opp	70				Furnished	442XSEWX-*3 (1)	200 I	Opp	70				Furnished
442XUEWX-*5 (1)	195 I	Opp	84				Furnished	442XUEWX-*3 (1)	195 I	Opp	84				Furnished
442XWEWX-*5 (1)	175 I	Opp	98				Furnished	442XWEWX-*3 (1)	175 I	Opp	98				Furnished
442XXEWX-*5 (1)	140 I	Opp	116				Furnished	442XXEWX-*3 (1)	140 I	Opp	116				Furnished

ONE SPEED - FORWARD & REVERSE

340XFEWX-*5 (3)	200 I	Opp	33	35	7-A-140(4)		Furnished	340XFEWX-*5 (3)	200 I	Opp	33	35	7-A-140(4)		Furnished
-----------------	-------	-----	----	----	------------	--	-----------	-----------------	-------	-----	----	----	------------	--	-----------

GEARED ADAPTERS

626XEWX-4HM	250 I	Eng					Furnished	626XEWX-3HM	250 I	Eng					Furnished
630XEWX-4HM	250 I	Eng					Furnished	630XEWX-3HM	250 I	Eng					Furnished
645XEWX-4HM	250 I	Eng					Furnished	645XEWX-3HM	250 I	Eng					Furnished

† I = Intermittent Torque Only - De-rate Torque Rating 30% for Continuous Duty.

C = Continuous or Intermittent Torque - No need to De-Rate Torque Rating.

IMPORTANT: Refer to the back of this transmission section and read all notes associated with this application page. Some notes may affect the proper PTO selection.

- (1) Input Gear Part No. 5-P-1061
(2) Input Gear Part No. 5-P-1095
(3) Input Gear Part No. 5-P-886
(4) Filler block furnished with PTO

FLR-79

EATON FULLER

CHELSEA®

FS-4205B

LEFT SIDE ONLY

RIGHT SIDE ONLY

TRANSMISSION GEAR DATA:

L.S. 06-BOLT Opening Gear FORWARD of Centerline
28 Teeth - R.H. HELIX

PITCH LINE TO APERTURE FACE:

1.1469" (29.1313MM)

TRANSMISSION GEAR DATA:

R.S. 06-BOLT Opening Gear FORWARD of Centerline
28 Teeth - R.H. HELIX

PITCH LINE TO APERTURE FACE:

1.1469" (29.1313MM)

CAUTION: Application Approval Required for PTO Output Shaft Speeds Above 2500 RPM

PTO Model	Torq I / C †	Dir Rot	Engine %		Filler Block	Adapter Assy	Stud Kit	PTO Model	Torq I / C †	Dir Rot	Engine %		Filler Block	Adapter Assy	Stud Kit
			Fwd	Rev							Fwd	Rev			
ONE SPEED - TWO GEAR - MECHANICAL SHIFT															
442XFEWX-*5 (2)	250 I	Opp	42				Furnished	442XFEWX-*3 (2)	250 I	Opp	42				Furnished
442XLEWX-*5 (1)	250 I	Opp	54				Furnished	442XLEWX-*3 (1)	250 I	Opp	54				Furnished
442XQEWX-*5 (1)	225 I	Opp	59				Furnished	442XQEWX-*3 (1)	225 I	Opp	59				Furnished
442XREWX-*5 (1)	225 I	Opp	68				Furnished	442XREWX-*3 (1)	225 I	Opp	68				Furnished
442XSEWX-*5 (1)	200 I	Opp	81				Furnished	442XSEWX-*3 (1)	200 I	Opp	81				Furnished
442XUEWX-*5 (1)	195 I	Opp	96				Furnished	442XUEWX-*3 (1)	195 I	Opp	96				Furnished
442XWEWX-*5 (1)	175 I	Opp	113				Furnished	442XWEWX-*3 (1)	175 I	Opp	113				Furnished
442XXEWX-*5 (1)	140 I	Opp	134				Furnished	442XXEWX-*3 (1)	140 I	Opp	134				Furnished
ONE SPEED - FORWARD & REVERSE															
340XFEWX-*5 (3)	200 I	Opp	38	40	7-A-140(4)		Furnished	340XFEWX-*5 (3)	200 I	Opp	38	40	7-A-140(4)		Furnished
GEARED ADAPTERS															
626XEWX-4HM	250 I	Eng					Furnished	626XEWX-3HM	250 I	Eng					Furnished
630XEWX-4HM	250 I	Eng					Furnished	630XEWX-3HM	250 I	Eng					Furnished
645XEWX-4HM	250 I	Eng					Furnished	645XEWX-3HM	250 I	Eng					Furnished

† I = Intermittent Torque Only - De-rate Torque Rating 30% for Continuous Duty.

C = Continuous or Intermittent Torque - No need to De-Rate Torque Rating.

IMPORTANT: Refer to the back of this transmission section and read all notes associated with this application page.
Some notes may affect the proper PTO selection.

- (1) Input Gear Part No. 5-P-1061
(2) Input Gear Part No. 5-P-1095
(3) Input Gear Part No. 5-P-886
(4) Filler block furnished with PTO

CHELSEA®

EATON FULLER

FLR-84LF

ES-11109 (Left Side Forward Opening)
 FS-6109A (Left Side Forward Opening)
 FS-8209A (ES11109)(Left Side Forward Opening)
 FS-6309A (Left Side Forward Opening)
 FS-8309 (Left Side Forward Opening)
 FS-6209A (Left Side Forward Opening)

LEFT FRONT SIDE ONLY

REAR SIDE ONLY

TRANSMISSION GEAR DATA:

L.F. 06-BOLT Opening Gear NON-STANDARD of Centerline
 32 Teeth - R.H. HELIX

PITCH LINE TO APERTURE FACE:

2.9730" (75.5142MM)

TRANSMISSION GEAR DATA:

REAR 00-BOLT Opening

PITCH LINE TO APERTURE FACE:

CAUTION: Application Approval Required for PTO Output Shaft Speeds Above 2500 RPM

PTO Model	Torq I / C †	Dir Rot	Engine %		Filler Block	Adapter Assy	Stud Kit	PTO Model	Torq I / C †	Dir Rot	Engine %		Filler Block	Adapter Assy	Stud Kit
			Fwd	Rev							Fwd	Rev			

ONE SPEED - TWO GEAR - MECHANICAL SHIFT

442XFAHX-*5 (2)	250 I	Eng	84			329182-1X	Furnished
442XHAXH-*5 (3)	250 I	Eng	97			329182-1X	Furnished
442XLAHX-*5 (1)	250 I	Eng	109			329182-1X	Furnished
442XQAHX-*5 (1)	225 I	Eng	118			329182-1X	Furnished
442XRAHX-*5 (1)	225 I	Eng	136			329182-1X	Furnished
442XSAHX-*5 (1)	200 I	Eng	162			329182-1X	Furnished
442XUAHX-*5 (1)	195 I	Eng	193			329182-1X	Furnished
442XWAHX-*5 (1)	175 I	Eng	228			329182-1X	Furnished
442XXAHX-*5 (1)	140 I	Eng	269			329182-1X	Furnished

ONE SPEED - TWO GEAR POWERSHIFT (AIR OR HYDRAULIC)

272XAAJX-*5 (4)	300 C	Eng	47			329182-1X	Furnished
272XBAJX-*5 (5)	300 C	Eng	58			329182-1X	Furnished
272XCAJX-*5 (6)	300 C	Eng	70			329182-1X	Furnished
272XD AJX-*5 (7)	300 C	Eng	84			329182-1X	Furnished
272XGAJX-*5 (8)	271 C	Eng	99			329182-1X	Furnished
272XKAJX-*5 (9)	242 C	Eng	111			329182-1X	Furnished
272XMAJX-*5 (10)	217 C	Eng	124			329182-1X	Furnished
272XPAJX-*5 (11)	194 C	Eng	138			329182-1X	Furnished
272XSAJX-*5 (12)	174 C	Eng	155			329182-1X	Furnished

REAR MOUNT & THRUSHAFT

511XRARW-*-* 590 C Opp 77

Furnished

† I = Intermittent Torque Only - De-rate Torque Rating 30% for Continuous Duty.

C = Continuous or Intermittent Torque - No need to De-Rate Torque Rating.

IMPORTANT: Refer to the back of this transmission section and read all notes associated with this application page. Some notes may affect the proper PTO selection.

- | | | |
|-------------------------------------|--------------------------------------|--------------------------------------|
| (1) Input Gear Part No. 5-P-1004 | (6) Input Gear Part No. 5-P-1510-3X | (11) Input Gear Part No. 5-P-1510-8X |
| (2) Input Gear Part No. 5-P-1077 | (7) Input Gear Part No. 5-P-1510-4X | (12) Input Gear Part No. 5-P-1510-9X |
| (3) Input Gear Part No. 5-P-1364 | (8) Input Gear Part No. 5-P-1510-5X | |
| (4) Input Gear Part No. 5-P-1510-1X | (9) Input Gear Part No. 5-P-1510-6X | |
| (5) Input Gear Part No. 5-P-1510-2X | (10) Input Gear Part No. 5-P-1510-7X | |

FLR-87

EATON FULLER

CHELSEA®

FSO-5206 (B)

LEFT SIDE ONLY

TRANSMISSION GEAR DATA:

L.S. 06-BOLT Opening Gear REAR of Centerline
47 Teeth - R.H. HELIX

PITCH LINE TO APERTURE FACE:

2.1970" (55.8038MM)

CAUTION: Application Approval Required for PTO Output Shaft Speeds Above 2500 RPM

PTO Model	Torq	Dir Rot	Engine %		Filler Block	Adapter Assy	Stud Kit	PTO Model	Torq	Dir Rot	Engine %		Filler Block	Adapter Assy	Stud Kit
	I / C †		Fwd	Rev					I / C †		Fwd	Rev			

ONE SPEED - TWO GEAR - MECHANICAL SHIFT

290QGFX-*6 (1) 175 I Opp 140

Furnished

† I = Intermittent Torque Only - De-rate Torque Rating 30% for Continuous Duty.

C = Continuous or Intermittent Torque - No need to De-Rate Torque Rating.

IMPORTANT: Refer to the back of this transmission section and read all notes associated with this application page. Some notes may affect the proper PTO selection.

(1) Input Gear Part No. 5-P-993

Eaton Fuller

FRO-11210C FRO-12210C FRO-13210C FRO-14210C FRO-15210C FRO-16210C FRO-16210R FRO-17210C	FRO-18210C FROF-15210C
--	---------------------------

BOTTOM SIDE ONLY	RIGHT SIDE ONLY
TRANSMISSION GEAR DATA: BOT 08-BOLT Opening Gear FORWARD of Centerline 47 Teeth - SPUR PITCH LINE TO APERTURE FACE: 0.8050" (20.4470MM)	TRANSMISSION GEAR DATA: R.S. 06-BOLT Opening Gear FORWARD of Centerline 45 Teeth - SPUR PITCH LINE TO APERTURE FACE: 1.0850" (27.5600MM)

CAUTION: Application Approval Required for PTO Output Shaft Speeds Above 2500 RPM

PTO Model	Torq I / C †	Dir Rot	Engine %		Filler Block	Adapter Assy	Stud Kit	PTO Model	Torq I / C †	Dir Rot	Engine %		Filler Block	Adapter Assy	Stud Kit
			Fwd	Rev							Fwd	Rev			

ONE SPEED - TWO GEAR - MECHANICAL SHIFT

489GAAHX-*5 (12)	250 I	Opp	64				Furnished	442GAAHX-*3 (12)	250 I	Opp	62				Furnished
489GCAHX-*5 (13)	250 I	Opp	82				Furnished	442GCAHX-*3 (13)	250 I	Opp	79				Furnished
489GFAHX-*5 (2)	250 I	Opp	102				Furnished	442GFAHX-*3 (2)	250 I	Opp	97				Furnished
489GHAHX-*5 (15)	250 I	Opp	118				Furnished	442GHAHX-*3 (15)	250 I	Opp	112				Furnished
489GLAHX-*5 (1)	250 I	Opp	132				Furnished	442GLAHX-*3 (1)	250 I	Opp	126				Furnished
489GQAHX-*5 (1)	225 I	Opp	142				Furnished	442GQAHX-*3 (1)	225 I	Opp	136				Furnished
489GRAHX-*5 (1)	225 I	Opp	164				Furnished	442GRAHX-*3 (1)	225 I	Opp	157				Furnished
489GSAHX-*5 (1)	200 I	Opp	195				Furnished	442GSAHX-*3 (1)	200 I	Opp	187				Furnished
489GUAHX-*5 (1)	195 I	Opp	233				Furnished	660GFAHX-*3 (10)	375 I	Opp	97				Furnished
489GWAHX-*5 (1)	175 I	Opp	274				Furnished	660GHAHX-*3 (15)	375 I	Opp	112				Furnished
680GFAHX-*3 (10)	375 I	Opp	102				Furnished	660GQAHX-*3 (11)	375 I	Opp	136				Furnished
680GHAHX-*3 (18)	375 I	Opp	118				Furnished	660GRAHX-*3 (17)	350 I	Opp	157				Furnished
680GQAHX-*3 (11)	375 I	Opp	142				Furnished	660GSAHX-*3 (14)	336 I	Opp	187				Furnished
680GRAHX-*3 (17)	350 I	Opp	164				Furnished								
680GSAHX-*3 (14)	322 I	Opp	195				Furnished								
823GBAHX-*3 (38)	750 I	Opp	69				Furnished								
823GDAHx-*3 (42)	750 I	Opp	82				Furnished								
823GGAHX-*3 (43)	705 I	Opp	89				Furnished								
823GJAHX-*3 (39)	599 I	Opp	105				Furnished								
823GMAHX-*3 (37)	511 I	Opp	123				Furnished								
823GRAHX-*3 (41)	370 I	Opp	170				Furnished								
880GBAHX-*3 (3)	500 I	Opp	69				Furnished								
880GDAHx-*3 (4)	500 I	Opp	82				Furnished								
880GGAHX-*3 (9)	500 I	Opp	89				Furnished								
880GJAHX-*3 (5)	500 I	Opp	105				Furnished								
880GMAHX-*3 (6)	500 I	Opp	123				Furnished								
880GQAHX-*3 (16)	435 I	Opp	144				Furnished								
880GRAHX-*3 (7)	370 I	Opp	170				Furnished								
880GTAHX-*3 (8)	287 I	Opp	219				Furnished								

ONE SPEED - TWO GEAR POWERSHIFT (AIR OR HYDRAULIC)

272XAAJX-*3 (28)	300 C	Opp	56		328481G	Furnished	272GAAJX-*3 (28)	300 C	Opp	54					Furnished
------------------	-------	-----	----	--	---------	-----------	------------------	-------	-----	----	--	--	--	--	-----------

Continued on Next Page

† I = Intermittent Torque Only - De-rate Torque Rating 30% for Continuous Duty.

C = Continuous or Intermittent Torque - No need to De-Rate Torque Rating.

IMPORTANT: Refer to the back of this transmission section and read all notes associated with this application page. Some notes may affect the proper PTO selection.

CAUTION: Eaton Transmission Division has established a MAXIMUM torque limit for the Transmission PTO driver gear. For all FR, FRO & FRL0 transmissions the MAXIMUM torque limit for the transmission PTO driver gear is 750 lb-ft [1017 Nm]. All torque limits on this application page reflect the 750 lb-ft [1017 Nm] limit at the Transmission PTO driver gear. Refer to the Chelsea PTO Torque Limit Chart in the front of this section for complete torque limit information.

CAUTION: Do not use geared adapters with 442 A and C ratios.

CAUTION: PTOs will not fit of the right side of FRO transmissions with factory installed trans coolers.

- | | | | | |
|----------------------------------|-----------------------------------|-----------------------------------|--------------------------------------|----------------------------------|
| (1) Input Gear Part No. 5-P-1004 | (6) Input Gear Part No. 5-P-1103 | (11) Input Gear Part No. 5-P-1246 | (16) Input Gear Part No. 5-P-1385 | (38) Input Gear Part No. 5-P-285 |
| (2) Input Gear Part No. 5-P-1077 | (7) Input Gear Part No. 5-P-1104 | (12) Input Gear Part No. 5-P-1280 | (17) Input Gear Part No. 5-P-1441 | (39) Input Gear Part No. 5-P-325 |
| (3) Input Gear Part No. 5-P-1100 | (8) Input Gear Part No. 5-P-1105 | (13) Input Gear Part No. 5-P-1287 | (18) Input Gear Part No. 5-P-1494 | (41) Input Gear Part No. 5-P-721 |
| (4) Input Gear Part No. 5-P-1101 | (9) Input Gear Part No. 5-P-1135 | (14) Input Gear Part No. 5-P-1322 | (28) Input Gear Part No. 5-P-1510-1X | (42) Input Gear Part No. 5-P-971 |
| (5) Input Gear Part No. 5-P-1102 | (10) Input Gear Part No. 5-P-1242 | (15) Input Gear Part No. 5-P-1364 | (37) Input Gear Part No. 5-P-283 | (43) Input Gear Part No. 5-P-980 |

FLR-88

EATON FULLER

CHELSEA®

FRO-11210C
FRO-12210C
FRO-13210C
FRO-14210C
FRO-15210C
FRO-16210C
FRO-16210R
FRO-17210C

FRO-18210C
FROF-15210C

BOTTOM SIDE ONLY

RIGHT SIDE ONLY

TRANSMISSION GEAR DATA:

BOT 08-BOLT Opening Gear FORWARD of Centerline
47 Teeth - SPUR

PITCH LINE TO APERTURE FACE:

0.8050" (20.4470MM)

TRANSMISSION GEAR DATA:

R.S. 06-BOLT Opening Gear FORWARD of Centerline
45 Teeth - SPUR

PITCH LINE TO APERTURE FACE:

1.0850" (27.5600MM)

CAUTION: Application Approval Required for PTO Output Shaft Speeds Above 2500 RPM

PTO Model	Torq l / C †	Dir Rot	Engine %		Filler Block	Adapter Assy	Stud Kit	PTO Model	Torq l / C †	Dir Rot	Engine %		Filler Block	Adapter Assy	Stud Kit
			Fwd	Rev							Fwd	Rev			

ONE SPEED - TWO GEAR POWERSHIFT (AIR OR HYDRAULIC)

282GBAJX-*3 (19)	300 C	Opp	69		8-A-032		Furnished	272GBAJX-*3 (29)	300 C	Opp	67				Furnished
282GCAJX-*3 (20)	300 C	Opp	83		8-A-032		Furnished	272GCAJX-*3 (30)	300 C	Opp	81				Furnished
282GDAJX-*3 (21)	300 C	Opp	100		8-A-032		Furnished	272GDAJX-*3 (31)	300 C	Opp	97				Furnished
282GGAJX-*3 (22)	300 C	Opp	119		8-A-032		Furnished	272GGAJX-*3 (32)	300 C	Opp	115				Furnished
282GKAJX-*3 (23)	300 C	Opp	133		8-A-032		Furnished	272GKAJX-*3 (33)	300 C	Opp	128				Furnished
282GMAJX-*3 (24)	300 C	Opp	148		8-A-032		Furnished	272GMAJX-*3 (34)	300 C	Opp	143				Furnished
282GPAJX-*3 (25)	300 C	Opp	166		8-A-032		Furnished	272GPAJX-*3 (35)	300 C	Opp	160				Furnished
282GSAJX-*3 (26)	300 C	Opp	185		8-A-032		Furnished	272GSAJX-*3 (36)	300 C	Opp	179				Furnished
282GTAJX-*3 (27)	300 C	Opp	208		8-A-032		Furnished								

ONE SPEED - TWO GEAR - POWERSHIFT (AIR)

885GBAHX-*3 (3)	500 l	Opp	69				Furnished								
885GGAHX-*3 (9)	500 l	Opp	89				Furnished								
885GJAHX-*3 (5)	500 l	Opp	105				Furnished								
885GMAHX-*3 (6)	500 l	Opp	123				Furnished								

ONE SPEED - FORWARD & REVERSE

348GFAHX-*5 (40)	200 l	Opp	89	93			Furnished	340GFAHX-*5 (40)	200 l	Opp	85	89	7-A-140(44)		Furnished
863GBAHX-*5	500 l	Opp	69	86			Furnished								

GEARED ADAPTERS

628GAHX-3AH	250 l	Eng					Furnished	626GAHX-3AH	250 l	Eng					Furnished
								630GAHX-3AH	250 l	Eng					Furnished
								645GAHX-3AH	250 l	Eng					Furnished

Continued on Next Page

† I = Intermittent Torque Only - De-rate Torque Rating 30% for Continuous Duty.

C = Continuous or Intermittent Torque - No need to De-Rate Torque Rating.

IMPORTANT: Refer to the back of this transmission section and read all notes associated with this application page. Some notes may affect the proper PTO selection.

CAUTION: Eaton Transmission Division has established a MAXIMUM torque limit for the Transmission PTO driver gear. For all FR, FRO & FRLO transmissions the MAXIMUM torque limit for the transmission PTO driver gear is 750 lb-ft [1017 Nm]. All torque limits on this application page reflect the 750 lb-ft [1017 Nm] limit at the Transmission PTO driver gear. Refer to the Chelsea PTO Torque Limit Chart in the front of this section for complete torque limit information.

CAUTION: Do not use geared adapters with 442 A and C ratios.

CAUTION: PTOs will not fit on the right side of FRO transmissions with factory installed trans coolers.

- | | | | | |
|---------------------------------------|---------------------------------------|---------------------------------------|--------------------------------------|--------------------------------------|
| (3) Input Gear Part No. 5-P-1100 | (20) Input Gear Part No. 5-P-1510-12X | (25) Input Gear Part No. 5-P-1510-17X | (31) Input Gear Part No. 5-P-1510-4X | (36) Input Gear Part No. 5-P-1510-9X |
| (5) Input Gear Part No. 5-P-1102 | (21) Input Gear Part No. 5-P-1510-13X | (26) Input Gear Part No. 5-P-1510-18X | (32) Input Gear Part No. 5-P-1510-5X | (40) Input Gear Part No. 5-P-581 |
| (6) Input Gear Part No. 5-P-1103 | (22) Input Gear Part No. 5-P-1510-14X | (27) Input Gear Part No. 5-P-1510-19X | (33) Input Gear Part No. 5-P-1510-6X | (44) Filler block furnished with PTO |
| (9) Input Gear Part No. 5-P-1135 | (23) Input Gear Part No. 5-P-1510-15X | (29) Input Gear Part No. 5-P-1510-2X | (34) Input Gear Part No. 5-P-1510-7X | |
| (19) Input Gear Part No. 5-P-1510-11X | (24) Input Gear Part No. 5-P-1510-16X | (30) Input Gear Part No. 5-P-1510-3X | (35) Input Gear Part No. 5-P-1510-8X | |

CHELSEA®

EATON FULLER

FLR-88

FRO-11210C	FRO-18210C
FRO-12210C	FROF-15210C
FRO-13210C	
FRO-14210C	
FRO-15210C	
FRO-16210C	
FRO-16210R	
FRO-17210C	

REAR SIDE ONLY**TRANSMISSION GEAR DATA:**

REAR 00-BOLT Opening

PITCH LINE TO APERTURE FACE:**CAUTION: Application Approval Required for PTO Output Shaft Speeds Above 2500 RPM**

PTO Model	Torq	Dir Rot	Engine %		Filler Block	Adapter Assy	Stud Kit	PTO Model	Torq	Dir Rot	Engine %		Filler Block	Adapter Assy	Stud Kit
	I / C †		Fwd	Rev					I / C †		Fwd	Rev			

REAR MOUNT - MECHANICAL SHIFT (10 SPEED TRANSMISSIONS)

541-LBJ-*.*	400 I	Eng	81				Furnished
541-MBJ-*.*	350 I	Eng	113				Furnished
541-NBJ-*.*	300 I	Eng	129				Furnished

† I = Intermittent Torque Only - De-rate Torque Rating 30% for Continuous Duty.

C = Continuous or Intermittent Torque - No need to De-Rate Torque Rating.

IMPORTANT: Refer to the back of this transmission section and read all notes associated with this application page. Some notes may affect the proper PTO selection.

CAUTION: Eaton Transmission Division has established a MAXIMUM torque limit for the Transmission PTO driver gear. For all FR, FRO & FRL0 transmissions the MAXIMUM torque limit for the transmission PTO driver gear is 750 lb-ft [1017 Nm]. All torque limits on this application page reflect the 750 lb-ft [1017 Nm] limit at the Transmission PTO driver gear. Refer to the Chelsea PTO Torque Limit Chart in the front of this section for complete torque limit information.

CAUTION: Do not use geared adapters with 442 A and C ratios.

CAUTION: PTOs will not fit on the right side of FRO transmissions with factory installed trans coolers.

Eaton Fuller

FLR-90

EATON FULLER

CHELSEA®

FR-11210B
FR-12210B
FR-13210B
FR-14210B
FR-15210B
FR-9210
FR-9210B
FRF-9210B

FRM-15210B (Thrushaft use BJ mounting)
FRW-15210B

BOTTOM SIDE ONLY

RIGHT SIDE ONLY

TRANSMISSION GEAR DATA:

BOT 08-BOLT Opening Gear FORWARD of Centerline
47 Teeth - SPUR

PITCH LINE TO APERTURE FACE:

0.8050" (20.4470MM)

TRANSMISSION GEAR DATA:

R.S. 06-BOLT Opening Gear FORWARD of Centerline
45 Teeth - SPUR

PITCH LINE TO APERTURE FACE:

1.0850" (27.5600MM)

CAUTION: Application Approval Required for PTO Output Shaft Speeds Above 2500 RPM

PTO Model	Torq l / C †	Dir Rot	Engine %		Filler Block	Adapter Assy	Stud Kit	PTO Model	Torq l / C †	Dir Rot	Engine %		Filler Block	Adapter Assy	Stud Kit
			Fwd	Rev							Fwd	Rev			

ONE SPEED - TWO GEAR - MECHANICAL SHIFT

221ZCAHX-*3	250 l	Opp	57		7-A-032(43)	328564G	Furnished	442GAAHX-*3 (12)	250 l	Opp	48				Furnished
221ZEAHX-*3	250 l	Opp	65			328564G	Furnished	442GCAHX-*3 (13)	250 l	Opp	61				Furnished
489GAAHX-*5 (12)	250 l	Eng	50				Furnished	442GFAHX-*3 (2)	250 l	Opp	75				Furnished
489GCAHX-*5 (13)	250 l	Eng	64				Furnished	442GHAHX-*3 (15)	250 l	Opp	87				Furnished
489GFAHX-*5 (2)	250 l	Opp	79				Furnished	442GLAHX-*3 (1)	250 l	Opp	97				Furnished
489GHAHX-*5 (15)	250 l	Opp	92				Furnished	442GQAHX-*3 (1)	225 l	Opp	105				Furnished
489GLAHX-*5 (1)	250 l	Opp	102				Furnished	442GRAHX-*3 (1)	225 l	Opp	121				Furnished
489GQAHX-*5 (1)	225 l	Opp	110				Furnished	442GSAHX-*3 (1)	200 l	Opp	145				Furnished
489GRAHX-*5 (1)	225 l	Opp	127				Furnished	442GUAHX-*3 (1)	195 l	Opp	171				Furnished
489GSAHX-*5 (1)	200 l	Opp	151				Furnished	442GWAHX-*3 (1)	175 l	Opp	208				Furnished
489GUAHX-*5 (1)	195 l	Opp	180				Furnished	442GAHX-*3 (1)	140 l	Opp	242				Furnished
489GWAHX-*5 (1)	175 l	Opp	212				Furnished	660GFAHX-*3 (10)	375 l	Opp	75				Furnished
680GFAHX-*3 (10)	375 l	Opp	79				Furnished	660GHAHX-*3 (15)	375 l	Opp	87				Furnished
680GHAHX-*3 (19)	375 l	Opp	92				Furnished	660GQAHX-*3 (11)	375 l	Opp	105				Furnished
680GQAHX-*3 (11)	375 l	Opp	110				Furnished	660GRAHX-*3 (18)	350 l	Opp	121				Furnished
680GRAHX-*3 (18)	350 l	Opp	127				Furnished	660GSAHX-*3 (14)	336 l	Opp	145				Furnished
680GSAHX-*3 (14)	322 l	Opp	151				Furnished								
823GTKTX-*3 (17)	305 l	Opp	159		8-A-165(43)		Furnished								
823GBAHX-*3 (34)	750 l	Opp	53				Furnished								
823GDAHx-*3 (41)	750 l	Opp	63				Furnished								
823GGAHX-*3 (42)	705 l	Opp	69				Furnished								
823GJAHX-*3 (35)	599 l	Opp	81				Furnished								
823GMAHX-*3 (33)	511 l	Opp	95				Furnished								
823GRAHX-*3 (40)	370 l	Opp	131				Furnished								
880GBAHX-*3 (3)	500 l	Opp	54				Furnished								
880GDAHx-*3 (4)	500 l	Opp	63				Furnished								
880GGAHX-*3 (9)	500 l	Opp	69				Furnished								
880GJAHX-*3 (5)	500 l	Opp	81				Furnished								
880GMAHX-*3 (6)	500 l	Opp	95				Furnished								
880GQAHX-*3 (16)	435 l	Opp	111				Furnished								
880GRAHX-*3 (7)	370 l	Opp	131				Furnished								
880GTAHX-*3 (8)	287 l	Opp	169				Furnished								

Continued on Next Page

† I = Intermittent Torque Only - De-rate Torque Rating 30% for Continuous Duty.

C = Continuous or Intermittent Torque - No need to De-Rate Torque Rating.

IMPORTANT: Refer to the back of this transmission section and read all notes associated with this application page. Some notes may affect the proper PTO selection.

CAUTION: Eaton Transmission Division has established a MAXIMUM torque limit for the Transmission PTO driver gear. For all FR, FRO & FRLO transmissions the MAXIMUM torque limit for the transmission PTO driver gear is 750 lb-ft [1017 Nm]. All torque limits on this application page reflect the 750 lb-ft [1017 Nm] limit at the Transmission PTO driver gear. Refer to the Chelsea PTO Torque Limit Chart in the front of this section for complete torque limit information.

CAUTION: Do not use geared adapters with 442 A and C ratios.

(1) Input Gear Part No. 5-P-1004	(7) Input Gear Part No. 5-P-1104	(13) Input Gear Part No. 5-P-1287	(19) Input Gear Part No. 5-P-1494	(42) Input Gear Part No. 5-P-980
(2) Input Gear Part No. 5-P-1077	(8) Input Gear Part No. 5-P-1105	(14) Input Gear Part No. 5-P-1322	(33) Input Gear Part No. 5-P-283	(43) Filler block furnished with PTO
(3) Input Gear Part No. 5-P-1100	(9) Input Gear Part No. 5-P-1135	(15) Input Gear Part No. 5-P-1364	(34) Input Gear Part No. 5-P-285	
(4) Input Gear Part No. 5-P-1101	(10) Input Gear Part No. 5-P-1242	(16) Input Gear Part No. 5-P-1385	(35) Input Gear Part No. 5-P-325	
(5) Input Gear Part No. 5-P-1102	(11) Input Gear Part No. 5-P-1246	(17) Input Gear Part No. 5-P-1395	(40) Input Gear Part No. 5-P-721	
(6) Input Gear Part No. 5-P-1103	(12) Input Gear Part No. 5-P-1280	(18) Input Gear Part No. 5-P-1441	(41) Input Gear Part No. 5-P-971	

CHELSEA®

EATON FULLER

FLR-90

FR-11210B
FR-12210B
FR-13210B
FR-14210B
FR-15210B
FR-9210
FR-9210B
FRF-9210B

FRM-15210B (Thrustaft use BJ mounting)
FRW-15210B

BOTTOM SIDE ONLY

RIGHT SIDE ONLY

TRANSMISSION GEAR DATA:

BOT 08-BOLT Opening Gear FORWARD of Centerline
47 Teeth - SPUR

PITCH LINE TO APERTURE FACE:

0.8050" (20.4470MM)

TRANSMISSION GEAR DATA:

R.S. 06-BOLT Opening Gear FORWARD of Centerline
45 Teeth - SPUR

PITCH LINE TO APERTURE FACE:

1.0850" (27.5600MM)

CAUTION: Application Approval Required for PTO Output Shaft Speeds Above 2500 RPM

PTO Model	Torq I / C †	Dir Rot	Engine %		Filler Block	Adapter Assy	Stud Kit	PTO Model	Torq I / C †	Dir Rot	Engine %		Filler Block	Adapter Assy	Stud Kit
			Fwd	Rev							Fwd	Rev			

ONE SPEED - TWO GEAR POWERSHIFT (AIR OR HYDRAULIC)

272XAAJX-*3 (29)	300 C	Opp	44			328481G	Furnished	272GAAJX-*3 (29)	300 C	Opp	42				Furnished
282GBAJX-*3 (20)	300 C	Opp	54		8-A-032		Furnished	272GBAJX-*3 (30)	300 C	Opp	51				Furnished
282GCAJX-*3 (21)	300 C	Opp	65		8-A-032		Furnished	272GCAJX-*3 (31)	300 C	Opp	62				Furnished
282GDAJX-*3 (22)	300 C	Opp	78		8-A-032		Furnished	272GDAJX-*3 (32)	300 C	Opp	74				Furnished
282GGAJX-*3 (23)	300 C	Opp	92		8-A-032		Furnished	272GGAJX-*3 (33)	300 C	Opp	88				Furnished
282GKAJX-*3 (24)	300 C	Opp	103		8-A-032		Furnished	272GKAJX-*3 (34)	300 C	Opp	99				Furnished
282GMAJX-*3 (25)	300 C	Opp	115		8-A-032		Furnished	272GMAJX-*3 (35)	300 C	Opp	110				Furnished
282GPAJX-*3 (26)	300 C	Opp	129		8-A-032		Furnished	272GPAJX-*3 (36)	300 C	Opp	123				Furnished
282GSAJX-*3 (27)	300 C	Opp	144		8-A-032		Furnished	272GSAJX-*3 (37)	300 C	Opp	138				Furnished
282GTAJX-*3 (28)	300 C	Opp	161		8-A-032		Furnished								

ONE SPEED - TWO GEAR - POWERSHIFT (AIR)

885GBAHX-*3 (3)	500 I	Opp	54				Furnished								
885GGAHX-*3 (9)	500 I	Opp	69				Furnished								
885GJAHX-*3 (5)	500 I	Opp	81				Furnished								
885GMAHX-*3 (6)	500 I	Opp	95				Furnished								

ONE SPEED - FORWARD & REVERSE

348GFAHX-*5 (38)	200 I	Opp	69	72			Furnished	340GFAHX-*5 (38)	200 I	Opp	66	69	7-A-140(43)		Furnished
863GBAHX-*5	500 I	Opp	54	66			Furnished								

GEARED ADAPTERS

628GAHX-3AH	250 I	Eng					Furnished	626GAHX-3AH	250 I	Eng					Furnished
								630GAHX-3AH	250 I	Eng					Furnished
								645GAHX-3AH	250 I	Eng					Furnished

Continued on Next Page

† I = Intermittent Torque Only - De-rate Torque Rating 30% for Continuous Duty.

C = Continuous or Intermittent Torque - No need to De-Rate Torque Rating.

IMPORTANT: Refer to the back of this transmission section and read all notes associated with this application page. Some notes may affect the proper PTO selection.

CAUTION: Eaton Transmission Division has established a MAXIMUM torque limit for the Transmission PTO driver gear. For all FR, FRO & FRL0 transmissions the MAXIMUM torque limit for the transmission PTO driver gear is 750 lb-ft [1017 Nm]. All torque limits on this application page reflect the 750 lb-ft [1017 Nm] limit at the Transmission PTO driver gear. Refer to the Chelsea PTO Torque Limit Chart in the front of this section for complete torque limit information.

CAUTION: Do not use geared adapters with 442 A and C ratios.

(3) Input Gear Part No. 5-P-1100 (21) Input Gear Part No. 5-P-1510-12X (26) Input Gear Part No. 5-P-1510-17X (31) Input Gear Part No. 5-P-1510-3X (36) Input Gear Part No. 5-P-1510-8X
(5) Input Gear Part No. 5-P-1102 (22) Input Gear Part No. 5-P-1510-13X (27) Input Gear Part No. 5-P-1510-18X (32) Input Gear Part No. 5-P-1510-4X (37) Input Gear Part No. 5-P-1510-9X
(6) Input Gear Part No. 5-P-1103 (23) Input Gear Part No. 5-P-1510-14X (28) Input Gear Part No. 5-P-1510-19X (33) Input Gear Part No. 5-P-1510-5X (38) Input Gear Part No. 5-P-581
(9) Input Gear Part No. 5-P-1135 (24) Input Gear Part No. 5-P-1510-15X (29) Input Gear Part No. 5-P-1510-1X (34) Input Gear Part No. 5-P-1510-6X (43) Filler block furnished with PTO
(20) Input Gear Part No. 5-P-1510-11X (25) Input Gear Part No. 5-P-1510-16X (30) Input Gear Part No. 5-P-1510-2X (35) Input Gear Part No. 5-P-1510-7X

FLR-90

EATON FULLER

CHELSEA®

FR-11210B	FRM-15210B (Thrushaft use BJ mounting)
FR-12210B	FRW-15210B
FR-13210B	
FR-14210B	
FR-15210B	
FR-9210	
FR-9210B	
FRF-9210B	

REAR SIDE ONLY**TRANSMISSION GEAR DATA:**

REAR 00-BOLT Opening

PITCH LINE TO APERTURE FACE:**CAUTION: Application Approval Required for PTO Output Shaft Speeds Above 2500 RPM**

PTO Model	Torq	Dir Rot	Engine %		Filler Block	Adapter Assy	Stud Kit	PTO Model	Torq	Dir Rot	Engine %		Filler Block	Adapter Assy	Stud Kit
	I / C †		Fwd	Rev					I / C †		Fwd	Rev			

REAR MOUNT - MECHANICAL SHIFT (10 SPEED TRANSMISSIONS)

541-LBJ-**-*(39)	400 I	Eng	63				Furnished
541-MBJ-**-*(38)	350 I	Eng	81				Furnished
541-NBJ-**-*(37)	300 I	Eng	92				Furnished

† I = Intermittent Torque Only - De-rate Torque Rating 30% for Continuous Duty.

C = Continuous or Intermittent Torque - No need to De-Rate Torque Rating.

IMPORTANT: Refer to the back of this transmission section and read all notes associated with this application page. Some notes may affect the proper PTO selection.

CAUTION: Eaton Transmission Division has established a MAXIMUM torque limit for the Transmission PTO driver gear. For all FR, FRO & FRLO transmissions the MAXIMUM torque limit for the transmission PTO driver gear is 750 lb-ft [1017 Nm]. All torque limits on this application page reflect the 750 lb-ft [1017 Nm] limit at the Transmission PTO driver gear. Refer to the Chelsea PTO Torque Limit Chart in the front of this section for complete torque limit information.

CAUTION: Do not use geared adapters with 442 A and C ratios.

(37) Input Gear Part No. 5-P-716
 (38) Input Gear Part No. 5-P-717
 (39) Input Gear Part No. 5-P-718

FRO-11210B
FRO-12210B
FRO-13210B
FRO-14210B
FRO-15210B
FRO-16210B

BOTTOM SIDE ONLY

RIGHT SIDE ONLY

TRANSMISSION GEAR DATA:

BOT 08-BOLT Opening Gear FORWARD of Centerline
47 Teeth - SPUR

PITCH LINE TO APERTURE FACE:

0.8050" (20.4470MM)

TRANSMISSION GEAR DATA:

R.S. 06-BOLT Opening Gear FORWARD of Centerline
45 Teeth - SPUR

PITCH LINE TO APERTURE FACE:

1.0850" (27.5590MM)

CAUTION: Application Approval Required for PTO Output Shaft Speeds Above 2500 RPM

PTO Model	Torq I / C †	Dir Rot	Engine %		Filler Block	Adapter Assy	Stud Kit	PTO Model	Torq I / C †	Dir Rot	Engine %		Filler Block	Adapter Assy	Stud Kit
			Fwd	Rev							Fwd	Rev			

ONE SPEED - TWO GEAR - MECHANICAL SHIFT

221ZCAHX-*3	250 I	Opp	76		7-A-032(49)	328564G	Furnished	442GAAHX-*3 (12)	250 I	Opp	64				Furnished
221ZEAHX-*3	250 I	Opp	87			328564G	Furnished	442GCAHX-*3 (13)	250 I	Opp	81				Furnished
489GAAHX-*5 (12)	250 I	Opp	66				Furnished	442GFAHX-*3 (2)	250 I	Opp	101				Furnished
489GCAHX-*5 (13)	250 I	Opp	85				Furnished	442GHAHX-*3 (15)	250 I	Opp	117				Furnished
489GFAHX-*5 (2)	250 I	Opp	105				Furnished	442GLAHX-*3 (1)	250 I	Opp	130				Furnished
489GHAHX-*5 (15)	250 I	Opp	122				Furnished	442GQAHX-*3 (1)	225 I	Opp	140				Furnished
489GLAHX-*5 (1)	250 I	Opp	136				Furnished	442GRAHX-*3 (1)	225 I	Opp	162				Furnished
489GQAHX-*5 (1)	225 I	Opp	146				Furnished	442GSAHX-*3 (1)	200 I	Opp	193				Furnished
489GRAHX-*5 (1)	225 I	Opp	170				Furnished	660GFAHX-*3 (10)	375 I	Opp	101				Furnished
489GSAHX-*5 (1)	200 I	Opp	202				Furnished	660GHAHX-*3 (15)	375 I	Opp	117				Furnished
489GUAHX-*5 (1)	195 I	Opp	241				Furnished	660GQAHX-*3 (11)	375 I	Opp	140				Furnished
489GWAHX-*5 (1)	175 I	Opp	283				Furnished	660GRAHX-*3 (18)	350 I	Opp	162				Furnished
680GFAHX-*3 (10)	375 I	Opp	105				Furnished	660GSAHX-*3 (14)	336 I	Opp	193				Furnished
680GHAHX-*3 (19)	375 I	Opp	122				Furnished								
680GQAHX-*3 (11)	375 I	Opp	146				Furnished								
680GRAHX-*3 (18)	350 I	Opp	170				Furnished								
680GSAHX-*3 (14)	322 I	Opp	202				Furnished								
823GKTX-*3 (17)	305 I	Opp	213		8-A-165(48)		Furnished								
823GBAHX-*3 (39)	750 I	Opp	71				Furnished								
823GDAHx-*3 (46)	750 I	Opp	85				Furnished								
823GGAHX-*3 (47)	705 I	Opp	92				Furnished								
823GJAHX-*3 (40)	599 I	Opp	108				Furnished								
823GMAHX-*3 (38)	511 I	Opp	127				Furnished								
823GRAHX-*3 (45)	370 I	Opp	176				Furnished								
880GBAHX-*3 (3)	500 I	Opp	72				Furnished								
880GDAHx-*3 (4)	500 I	Opp	85				Furnished								
880GGAHX-*3 (9)	500 I	Opp	92				Furnished								
880GJAHX-*3 (5)	500 I	Opp	108				Furnished								
880GMAHX-*3 (6)	500 I	Opp	127				Furnished								
880GQAHX-*3 (16)	435 I	Opp	149				Furnished								
880GRAHX-*3 (7)	370 I	Opp	176				Furnished								
880GTAHX-*3 (8)	287 I	Opp	226				Furnished								

Continued on Next Page

† I = Intermittent Torque Only - De-rate Torque Rating 30% for Continuous Duty.

C = Continuous or Intermittent Torque - No need to De-Rate Torque Rating.

IMPORTANT: Refer to the back of this transmission section and read all notes associated with this application page. Some notes may affect the proper PTO selection.

CAUTION: Eaton Transmission Division has established a MAXIMUM torque limit for the Transmission PTO driver gear. For all FR, FRO & FRL0 transmissions the MAXIMUM torque limit for the transmission PTO driver gear is 750 lb-ft [1017 Nm]. All torque limits on this application page reflect the 750 lb-ft [1017 Nm] limit at the Transmission PTO driver gear. Refer to the Chelsea PTO Torque Limit Chart in the front of this section for complete torque limit information.

CAUTION: Do not use geared adapters with 442 A and C ratios.

- | | | | | |
|----------------------------------|-----------------------------------|-----------------------------------|-----------------------------------|--------------------------------------|
| (1) Input Gear Part No. 5-P-1004 | (7) Input Gear Part No. 5-P-1104 | (13) Input Gear Part No. 5-P-1287 | (19) Input Gear Part No. 5-P-1494 | (47) Input Gear Part No. 5-P-980 |
| (2) Input Gear Part No. 5-P-1077 | (8) Input Gear Part No. 5-P-1105 | (14) Input Gear Part No. 5-P-1322 | (38) Input Gear Part No. 5-P-283 | (48) Filler block furnished with PTO |
| (3) Input Gear Part No. 5-P-1100 | (9) Input Gear Part No. 5-P-1135 | (15) Input Gear Part No. 5-P-1364 | (39) Input Gear Part No. 5-P-285 | (49) Furnished, but not required |
| (4) Input Gear Part No. 5-P-1101 | (10) Input Gear Part No. 5-P-1242 | (16) Input Gear Part No. 5-P-1385 | (40) Input Gear Part No. 5-P-325 | |
| (5) Input Gear Part No. 5-P-1102 | (11) Input Gear Part No. 5-P-1246 | (17) Input Gear Part No. 5-P-1395 | (45) Input Gear Part No. 5-P-721 | |
| (6) Input Gear Part No. 5-P-1103 | (12) Input Gear Part No. 5-P-1280 | (18) Input Gear Part No. 5-P-1441 | (46) Input Gear Part No. 5-P-971 | |

FLR-91

EATON FULLER

CHELSEA®

FRO-11210B
FRO-12210B
FRO-13210B
FRO-14210B
FRO-15210B
FRO-16210B

BOTTOM SIDE ONLY

RIGHT SIDE ONLY

TRANSMISSION GEAR DATA:

BOT 08-BOLT Opening Gear FORWARD of Centerline
47 Teeth - SPUR

PITCH LINE TO APERTURE FACE:

0.8050" (20.4470MM)

TRANSMISSION GEAR DATA:

R.S. 06-BOLT Opening Gear FORWARD of Centerline
45 Teeth - SPUR

PITCH LINE TO APERTURE FACE:

1.0850" (27.5590MM)

CAUTION: Application Approval Required for PTO Output Shaft Speeds Above 2500 RPM

PTO Model	Torq I / C †	Dir Rot	Engine %		Filler Block	Adapter Assy	Stud Kit	PTO Model	Torq I / C †	Dir Rot	Engine %		Filler Block	Adapter Assy	Stud Kit
			Fwd	Rev							Fwd	Rev			

ONE SPEED - TWO GEAR POWERSHIFT (AIR OR HYDRAULIC)

272XAAJX-*3 (29)	300 C	Opp	58			328481G	Furnished	272GAAJX-*3 (29)	300 C	Opp	56				Furnished
282GBAJX-*3 (20)	300 C	Opp	72		8-A-032		Furnished	272GBAJX-*3 (30)	300 C	Opp	69				Furnished
282GCAJX-*3 (21)	300 C	Opp	87		8-A-032		Furnished	272GCAJX-*3 (31)	300 C	Opp	83				Furnished
282GDAJX-*3 (22)	300 C	Opp	104		8-A-032		Furnished	272GDAJX-*3 (32)	300 C	Opp	99				Furnished
282GGAJX-*3 (23)	300 C	Opp	123		8-A-032		Furnished	272GGAJX-*3 (33)	300 C	Opp	118				Furnished
282GKAJX-*3 (24)	300 C	Opp	138		8-A-032		Furnished	272GKAJX-*3 (34)	300 C	Opp	132				Furnished
282GMAJX-*3 (25)	300 C	Opp	154		8-A-032		Furnished	272GMAJX-*3 (35)	300 C	Opp	148				Furnished
282GPAJX-*3 (26)	300 C	Opp	172		8-A-032		Furnished	272GPAJX-*3 (36)	300 C	Opp	165				Furnished
282GSAJX-*3 (27)	300 C	Opp	193		8-A-032		Furnished	272GSAJX-*3 (37)	300 C	Opp	184				Furnished
282GTAJX-*3 (28)	300 C	Opp	215		8-A-032		Furnished								

ONE SPEED - TWO GEAR - POWERSHIFT (AIR)

885GBAHX-*3 (3)	500 I	Opp	72				Furnished								
885GGAHX-*3 (9)	500 I	Opp	92				Furnished								
885GJAHX-*3 (5)	500 I	Opp	108				Furnished								
885GMAHX-*3 (6)	500 I	Opp	127				Furnished								

ONE SPEED - FORWARD & REVERSE

348GFAHX-*5 (41)	200 I	Opp	92	96			Furnished	340GFAHX-*5 (41)	200 I	Opp	88	92	7-A-140(49)		Furnished
863GBAHX-*5	500 I	Opp	72	89			Furnished								

GEARED ADAPTERS

628GAHX-3AH	250 I	Eng					Furnished	626GAHX-3AH	250 I	Eng					Furnished
								630GAHX-3AH	250 I	Eng					Furnished
								645GAHX-3AH	250 I	Eng					Furnished

Continued on Next Page

† I = Intermittent Torque Only - De-rate Torque Rating 30% for Continuous Duty.

C = Continuous or Intermittent Torque - No need to De-Rate Torque Rating.

IMPORTANT: Refer to the back of this transmission section and read all notes associated with this application page. Some notes may affect the proper PTO selection.

CAUTION: Eaton Transmission Division has established a MAXIMUM torque limit for the Transmission PTO driver gear. For all FR, FRO & FRLO transmissions the MAXIMUM torque limit for the transmission PTO driver gear is 750 lb-ft [1017 Nm]. All torque limits on this application page reflect the 750 lb-ft [1017 Nm] limit at the Transmission PTO driver gear. Refer to the Chelsea PTO Torque Limit Chart in the front of this section for complete torque limit information.

CAUTION: Do not use geared adapters with 442 A and C ratios.

(3) Input Gear Part No. 5-P-1100	(21) Input Gear Part No. 5-P-1510-12X	(26) Input Gear Part No. 5-P-1510-17X	(31) Input Gear Part No. 5-P-1510-3X	(36) Input Gear Part No. 5-P-1510-8X
(5) Input Gear Part No. 5-P-1102	(22) Input Gear Part No. 5-P-1510-13X	(27) Input Gear Part No. 5-P-1510-18X	(32) Input Gear Part No. 5-P-1510-4X	(37) Input Gear Part No. 5-P-1510-9X
(6) Input Gear Part No. 5-P-1103	(23) Input Gear Part No. 5-P-1510-14X	(28) Input Gear Part No. 5-P-1510-19X	(33) Input Gear Part No. 5-P-1510-5X	(41) Input Gear Part No. 5-P-581
(9) Input Gear Part No. 5-P-1135	(24) Input Gear Part No. 5-P-1510-15X	(29) Input Gear Part No. 5-P-1510-1X	(34) Input Gear Part No. 5-P-1510-6X	(49) Furnished, but not required
(20) Input Gear Part No. 5-P-1510-11X	(25) Input Gear Part No. 5-P-1510-16X	(30) Input Gear Part No. 5-P-1510-2X	(35) Input Gear Part No. 5-P-1510-7X	

CHELSEA®

EATON FULLER

FLR-91

FRO-11210B
FRO-12210B
FRO-13210B
FRO-14210B
FRO-15210B
FRO-16210B

REAR SIDE ONLY

TRANSMISSION GEAR DATA:

REAR 00-BOLT Opening

PITCH LINE TO APERTURE FACE:

CAUTION: Application Approval Required for PTO Output Shaft Speeds Above 2500 RPM

PTO Model	Torq	Dir Rot	Engine %		Filler Block	Adapter Assy	Stud Kit	PTO Model	Torq	Dir Rot	Engine %		Filler Block	Adapter Assy	Stud Kit
	I / C †		Fwd	Rev					I / C †		Fwd	Rev			

REAR MOUNT - MECHANICAL SHIFT (10 SPEED TRANSMISSIONS)

541-LBJ-*. (44)	400 I	Eng	84				Furnished
541-MBJ-*. (43)	350 I	Eng	108				Furnished
541-NBJ-*. (42)	300 I	Eng	123				Furnished

† I = Intermittent Torque Only - De-rate Torque Rating 30% for Continuous Duty.

C = Continuous or Intermittent Torque - No need to De-Rate Torque Rating.

IMPORTANT: Refer to the back of this transmission section and read all notes associated with this application page. Some notes may affect the proper PTO selection.**CAUTION:** Eaton Transmission Division has established a MAXIMUM torque limit for the Transmission PTO driver gear. For all FR, FRO & FRL0 transmissions the MAXIMUM torque limit for the transmission PTO driver gear is 750 lb-ft [1017 Nm]. All torque limits on this application page reflect the 750 lb-ft [1017 Nm] limit at the Transmission PTO driver gear. Refer to the Chelsea PTO Torque Limit Chart in the front of this section for complete torque limit information.**CAUTION:** Do not use geared adapters with 442 A and C ratios.(42) Input Gear Part No. 5-P-716
(43) Input Gear Part No. 5-P-717
(44) Input Gear Part No. 5-P-718

FLR-92

EATON FULLER

CHELSEA®

F-5405B-DM3 (UltraShift HV)
F-6405B-DM3 (UltraShift HV)
FO-5406B-DM3 (UltraShift HV)
FO-6406A-ASW
FO-6406A-ASX
FO-6406A-AW3
FO-6406B-DM3 (UltraShift HV)
FO-8406A-ASW

FO-8406A-ASX
FO-8406A-AW3
FSO-5406A
FSO-6406A (Eaton Brazil)
FSO-8406A (Eaton Brazil)

LEFT SIDE ONLY

RIGHT SIDE ONLY

TRANSMISSION GEAR DATA:

L.S. 06-BOLT Opening Gear FORWARD of Centerline
48 Teeth - R.H. HELIX

PITCH LINE TO APERTURE FACE:

0.4900" (12.4460MM)

TRANSMISSION GEAR DATA:

R.S. 06-BOLT Opening Gear FORWARD of Centerline
48 Teeth - R.H. HELIX

PITCH LINE TO APERTURE FACE:

0.4900" (12.4460MM)

CAUTION: Application Approval Required for PTO Output Shaft Speeds Above 2500 RPM

PTO Model	Torq l / C †	Dir Rot	Engine %		Filler Block	Adapter Assy	Stud Kit	PTO Model	Torq l / C †	Dir Rot	Engine %		Filler Block	Adapter Assy	Stud Kit
			Fwd	Rev							Fwd	Rev			

ONE SPEED - TWO GEAR - MECHANICAL SHIFT

442KLJKX-*5 (1)	250 l	Opp	99	7-A-500	7170-5X	442KLJKX-*3 (1)	250 l	Opp	99	7-A-500	7170-5X
442KQJKX-*5 (1)	225 l	Opp	106	7-A-500	7170-5X	442KQJKX-*3 (1)	225 l	Opp	106	7-A-500	7170-5X
442KRJKX-*5 (1)	225 l	Opp	123	7-A-500	7170-5X	442KRJKX-*3 (1)	225 l	Opp	123	7-A-500	7170-5X
442KSJKX-*5 (1)	200 l	Opp	146	7-A-500	7170-5X	442KSJKX-*3 (1)	200 l	Opp	146	7-A-500	7170-5X
442KUJKX-*5 (1)	195 l	Opp	174	7-A-500	7170-5X	442KUJKX-*3 (1)	195 l	Opp	174	7-A-500	7170-5X
442KWJKX-*5 (1)	175 l	Opp	205	7-A-500	7170-5X	442KWJKX-*3 (1)	175 l	Opp	205	7-A-500	7170-5X
442KXJKX-*5 (1)	140 l	Opp	242	7-A-500	7170-5X	442KXJKX-*3 (1)	140 l	Opp	242	7-A-500	7170-5X

ONE SPEED - TWO GEAR POWERSHIFT (AIR OR HYDRAULIC)

272KAJKX-*5 (3)	300 C	Opp	50	7-A-240	7170-3X	272KAJKX-*3 (3)	300 C	Opp	50	7-A-240	7170-3X
272KBJKX-*5 (4)	300 C	Opp	62	7-A-240	7170-3X	272KBJKX-*3 (4)	300 C	Opp	62	7-A-240	7170-3X
272KCJKX-*5 (5)	300 C	Opp	74	7-A-240	7170-3X	272KCJKX-*3 (5)	300 C	Opp	74	7-A-240	7170-3X
272KDJKX-*5 (6)	300 C	Opp	89	7-A-240	7170-3X	272KDJKX-*3 (6)	300 C	Opp	89	7-A-240	7170-3X
272KGJKX-*5 (7)	276 C	Opp	106	7-A-240	7170-3X	272KGJKX-*3 (7)	276 C	Opp	106	7-A-240	7170-3X
272KKJKX-*5 (8)	246 C	Opp	118	7-A-240	7170-3X	272KKJKX-*3 (8)	246 C	Opp	118	7-A-240	7170-3X
272KMJKX-*5 (9)	220 C	Opp	132	7-A-240	7170-3X	272KMJKX-*3 (9)	220 C	Opp	132	7-A-240	7170-3X
272KPJKX-*5 (10)	197 C	Opp	148	7-A-240	7170-3X	272KPJKX-*3 (10)	197 C	Opp	148	7-A-240	7170-3X
272KSJKX-*5 (11)	176 C	Opp	165	7-A-240	7170-3X	272KSJKX-*3 (11)	176 C	Opp	165	7-A-240	7170-3X

GEARED ADAPTERS

626KJKX-4JL (2)	250 l	Eng	7-A-500	7170-5X	626KJKX-3JL (2)	250 l	Eng	7-A-500	7170-5X
630KJKX-4JL (2)	250 l	Eng	7-A-500	7170-5X	630KJKX-3JL (2)	250 l	Eng	7-A-500	7170-5X
645KJKX-4JL (2)	250 l	Eng	7-A-500	7170-5X	645KJKX-3JL (2)	250 l	Eng	7-A-500	7170-5X

† I = Intermittent Torque Only - De-rate Torque Rating 30% for Continuous Duty.

C = Continuous or Intermittent Torque - No need to De-Rate Torque Rating.

IMPORTANT: Refer to the back of this transmission section and read all notes associated with this application page. Some notes may affect the proper PTO selection.

CAUTION: INPUT SIGNAL REQUIRED - The Eaton ASW, AW3, ASX & DM transmissions must have an input signal from the Power Take-Off when it is active. In this active state, the clutch engagement is controlled when the operator raises the engine speed to engage the clutch and drive the transmission main box countershaft. Minimum engine/transmission speed required for PTO operation is 1000 RPM, REFER to Eaton publication "TRIG-2600" for complete wiring information. INCORRECT or NO PTO interface signal to the transmission will result in uncontrolled engagement of the clutch during PTO operation.

- (1) Input Gear Part No. 5-P-1261 (6) Input Gear Part No. 5-P-1513-4X (11) Input Gear Part No. 5-P-1513-9X
 (2) Input Gear Part No. 5-P-1262 (7) Input Gear Part No. 5-P-1513-5X
 (3) Input Gear Part No. 5-P-1513-1X (8) Input Gear Part No. 5-P-1513-6X
 (4) Input Gear Part No. 5-P-1513-2X (9) Input Gear Part No. 5-P-1513-7X
 (5) Input Gear Part No. 5-P-1513-3X (10) Input Gear Part No. 5-P-1513-8X

CHELSEA®

EATON FULLER

FLR-92Hy

EH-8E306A-UP (Hybrid Electric System)	EH-6E706B-CD (Hybrid Electric System)
EH-8E306A-CD (Hybrid Electric System)	EH-6E706B-P (Hybrid Electric System)
EH-8E306A-UPG (Hybrid Electric System)	EH-8E406A-CD (Hybrid Electric System)
EH-8E406A-CDR (Hybrid Electric System)	
EH-8E406A-P (Hybrid Electric System)	
EH-8E406A-T (Hybrid Electric System)	
EH-8E406A-UP (Hybrid Electric System)	
EH-8E406A-UPG (Hybrid Electric System)	

LEFT SIDE ONLY**TRANSMISSION GEAR DATA:**L.S. 06-BOLT Opening Gear FORWARD of Centerline
48 Teeth - R.H. HELIX**PITCH LINE TO APERTURE FACE:**

0.4900" (12.4460MM)

CAUTION: Application Approval Required for PTO Output Shaft Speeds Above 2500 RPM

PTO Model	Torq I / C †	Dir Rot	Engine %		Filler Block	Adapter Assy	Stud Kit	PTO Model	Torq I / C †	Dir Rot	Engine %		Filler Block	Adapter Assy	Stud Kit
			Fwd	Rev							Fwd	Rev			

ONE SPEED - TWO GEAR - MECHANICAL SHIFT

442KLJKX-*5 (1)	250 I	Opp	99		7-A-500		7170-5X
442KQJKX-*5 (1)	225 I	Opp	106		7-A-500		7170-5X
442KRJKX-*5 (1)	225 I	Opp	123		7-A-500		7170-5X
442KSJKX-*5 (1)	200 I	Opp	146		7-A-500		7170-5X
442KUJKX-*5 (1)	195 I	Opp	174		7-A-500		7170-5X
442KWJKX-*5 (1)	175 I	Opp	205		7-A-500		7170-5X
442KXJKX-*5 (1)	140 I	Opp	242		7-A-500		7170-5X

ONE SPEED - TWO GEAR POWERSHIFT (AIR OR HYDRAULIC)

272KAJKX-*5 (3)	300 C	Opp	50		7-A-240		7170-5X
272KBJKX-*5 (4)	300 C	Opp	62		7-A-240		7170-5X
272KCJKX-*5 (5)	300 C	Opp	74		7-A-240		7170-5X
272KDJKX-*5 (6)	300 C	Opp	89		7-A-240		7170-5X
272KGJKX-*5 (7)	276 C	Opp	106		7-A-240		7170-5X
272KKJKX-*5 (8)	246 C	Opp	118		7-A-240		7170-5X
272KMJKX-*5 (9)	220 C	Opp	132		7-A-240		7170-5X
272KPJKX-*5 (10)	197 C	Opp	148		7-A-240		7170-5X
272KSJKX-*5 (11)	176 C	Opp	165		7-A-240		7170-5X

ONE SPEED - FORWARD & REVERSE

352KSJKX-*5 (1)	140 I	Opp	148	192	7-A-500(T)		7170-5X
-----------------	-------	-----	-----	-----	------------	--	---------

GEARED ADAPTERS

626KJKX-4JL (2)	250 I	Eng			7-A-500		7170-5X
630KJKX-4JL (2)	250 I	Eng			7-A-500		7170-5X
645KJKX-4JL (2)	250 I	Eng			7-A-500		7170-5X

† I = Intermittent Torque Only - De-rate Torque Rating 30% for Continuous Duty.

C = Continuous or Intermittent Torque - No need to De-Rate Torque Rating.

IMPORTANT: Refer to the back of this transmission section and read all notes associated with this application page. Some notes may affect the proper PTO selection.

- | | | |
|-------------------------------------|--------------------------------------|--------------------------------------|
| (1) Input Gear Part No. 5-P-1261 | (6) Input Gear Part No. 5-P-1513-4X | (11) Input Gear Part No. 5-P-1513-9X |
| (2) Input Gear Part No. 5-P-1262 | (7) Input Gear Part No. 5-P-1513-5X | |
| (3) Input Gear Part No. 5-P-1513-1X | (8) Input Gear Part No. 5-P-1513-6X | |
| (4) Input Gear Part No. 5-P-1513-2X | (9) Input Gear Part No. 5-P-1513-7X | |
| (5) Input Gear Part No. 5-P-1513-3X | (10) Input Gear Part No. 5-P-1513-8X | |

FLR-94

EATON FULLER

CHELSEA®

FSB-5406B
FSB-6406B
FSB-6206A

LEFT SIDE ONLY

RIGHT SIDE ONLY

TRANSMISSION GEAR DATA:

L.S. 06-BOLT Opening Gear FORWARD of Centerline
38 Teeth - R.H. HELIX

PITCH LINE TO APERTURE FACE:

1.0850" (27.5590MM)

TRANSMISSION GEAR DATA:

R.S. 06-BOLT Opening Gear FORWARD of Centerline
38 Teeth - R.H. HELIX

PITCH LINE TO APERTURE FACE:

1.0850" (27.5590MM)

CAUTION: Application Approval Required for PTO Output Shaft Speeds Above 2500 RPM

PTO Model	Torq l / C †	Dir Rot	Engine %		Filler Block	Adapter Assy	Stud Kit	PTO Model	Torq l / C †	Dir Rot	Engine %		Filler Block	Adapter Assy	Stud Kit
			Fwd	Rev							Fwd	Rev			

ONE SPEED - TWO GEAR - MECHANICAL SHIFT

442XFESX-*5 (2)	250 l	Opp	53		7-A-062		Furnished	442XFESX-*3 (2)	250 l	Opp	53		7-A-062		Furnished
442XLESX-*5 (1)	250 l	Opp	69		7-A-062		Furnished	442XLESX-*3 (1)	250 l	Opp	69		7-A-062		Furnished
442XQESX-*5 (1)	225 l	Opp	74		7-A-062		Furnished	442XQESX-*3 (1)	225 l	Opp	74		7-A-062		Furnished
442XRESX-*5 (1)	225 l	Opp	85		7-A-062		Furnished	442XRESX-*3 (1)	225 l	Opp	85		7-A-062		Furnished
442XSESX-*5 (1)	200 l	Opp	102		7-A-062		Furnished	442XSESX-*3 (1)	200 l	Opp	102		7-A-062		Furnished
442XUESX-*5 (1)	195 l	Opp	121		7-A-062		Furnished	442XUESX-*3 (1)	195 l	Opp	121		7-A-062		Furnished
442XWESX-*5 (1)	175 l	Opp	143		7-A-062		Furnished	442XWESX-*3 (1)	175 l	Opp	143		7-A-062		Furnished
442XXESX-*5 (1)	140 l	Opp	169		7-A-062		Furnished	442XXESX-*3 (1)	140 l	Opp	169		7-A-062		Furnished

ONE SPEED - TWO GEAR POWERSHIFT (AIR OR HYDRAULIC)

272XAESX-*5 (3)	300 C	Opp	32				Furnished	272XAESX-*3 (3)	300 C	Opp	32				Furnished
272XBESX-*5 (4)	300 C	Opp	39				Furnished	272XBESX-*3 (4)	300 C	Opp	39				Furnished
272XCESX-*5 (5)	300 C	Opp	47				Furnished	272XCESX-*3 (5)	300 C	Opp	47				Furnished
272XDESX-*5 (6)	300 C	Opp	57				Furnished	272XDESX-*3 (6)	300 C	Opp	57				Furnished
272XGESX-*5 (7)	300 C	Opp	67				Furnished	272XGESX-*3 (7)	300 C	Opp	67				Furnished
272XKESX-*5 (8)	300 C	Opp	75				Furnished	272XKESX-*3 (8)	300 C	Opp	75				Furnished
272XMESX-*5 (9)	300 C	Opp	84				Furnished	272XMESX-*3 (9)	300 C	Opp	84				Furnished
272XPESX-*5 (10)	286 C	Opp	94				Furnished	272XPESX-*3 (10)	286 C	Opp	94				Furnished
272XSESX-*5 (11)	256 C	Opp	105				Furnished	272XSESX-*3 (11)	256 C	Opp	105				Furnished

ONE SPEED - POWERSHIFT LOW PROFILE (AIR OR HYDRAULIC)

272MAESX-*5 (3)	300 C	Opp	32				Furnished	272MAESX-*3 (3)	300 C	Opp	32				Furnished
272MBESX-*5 (4)	300 C	Opp	39				Furnished	272MBESX-*3 (4)	300 C	Opp	39				Furnished
272MCESX-*5 (5)	300 C	Opp	47				Furnished	272MCESX-*3 (5)	300 C	Opp	47				Furnished
272MDESX-*5 (6)	300 C	Opp	57				Furnished	272MDESX-*3 (6)	300 C	Opp	57				Furnished
272MGESX-*5 (7)	300 C	Opp	67				Furnished	272MGESX-*3 (7)	300 C	Opp	67				Furnished
272MKESX-*5 (8)	300 C	Opp	75				Furnished	272MKESX-*3 (8)	300 C	Opp	75				Furnished
272MMESX-*5 (9)	300 C	Opp	84				Furnished	272MMESX-*3 (9)	300 C	Opp	84				Furnished
272MPESX-*5 (10)	286 C	Opp	94				Furnished	272MPESX-*3 (10)	286 C	Opp	94				Furnished
272MSESX-*5 (11)	256 C	Opp	105				Furnished	272MSESX-*3 (11)	256 C	Opp	105				Furnished

Continued on Next Page

† I = Intermittent Torque Only - De-rate Torque Rating 30% for Continuous Duty.

C = Continuous or Intermittent Torque - No need to De-Rate Torque Rating.

IMPORTANT: Refer to the back of this transmission section and read all notes associated with this application page. Some notes may affect the proper PTO selection.

- (1) Input Gear Part No. 5-P-1059
- (2) Input Gear Part No. 5-P-1092
- (3) Input Gear Part No. 5-P-1512-1X
- (4) Input Gear Part No. 5-P-1512-2X
- (5) Input Gear Part No. 5-P-1512-3X
- (6) Input Gear Part No. 5-P-1512-4X
- (7) Input Gear Part No. 5-P-1512-5X
- (8) Input Gear Part No. 5-P-1512-6X
- (9) Input Gear Part No. 5-P-1512-7X
- (10) Input Gear Part No. 5-P-1512-8X
- (11) Input Gear Part No. 5-P-1512-9X

CHELSEA®

EATON FULLER

FLR-94

FSB-5406B
FSB-6406B
FSB-6206A

LEFT SIDE ONLY

RIGHT SIDE ONLY

TRANSMISSION GEAR DATA:

L.S. 06-BOLT Opening Gear FORWARD of Centerline
38 Teeth - R.H. HELIX

PITCH LINE TO APERTURE FACE:

1.0850" (27.5590MM)

TRANSMISSION GEAR DATA:

R.S. 06-BOLT Opening Gear FORWARD of Centerline
38 Teeth - R.H. HELIX

PITCH LINE TO APERTURE FACE:

1.0850" (27.5590MM)

CAUTION: Application Approval Required for PTO Output Shaft Speeds Above 2500 RPM

PTO Model	Torq	Dir Rot	Engine %		Filler Block	Adapter Assy	Stud Kit	PTO Model	Torq	Dir Rot	Engine %		Filler Block	Adapter Assy	Stud Kit
	I / C †		Fwd	Rev					I / C †		Fwd	Rev			
ONE SPEED - FORWARD & REVERSE															
340XFESX-*5 (12)	200 I	Opp	48	51	7-A-093 7-A-140(13)		328170-76X	340XFESX-*5 (12)	200 I	Opp	48	51	7-A-093 7-A-140(13)		328170-76X

GEARED ADAPTERS

626XESX-4HL	250 I	Eng			7-A-062	Furnished	626XESX-3HL	250 I	Eng				7-A-062	Furnished
630XESX-4HL	250 I	Eng			7-A-062	Furnished	630XESX-3HL	250 I	Eng				7-A-062	Furnished
645XESX-4HL	250 I	Eng			7-A-062	Furnished	645XESX-3HL	250 I	Eng				7-A-062	Furnished

† I = Intermittent Torque Only - De-rate Torque Rating 30% for Continuous Duty.

C = Continuous or Intermittent Torque - No need to De-Rate Torque Rating.

IMPORTANT: Refer to the back of this transmission section and read all notes associated with this application page. Some notes may affect the proper PTO selection.

(12) Input Gear Part No. 5-P-884
(13) Furnished, but not required

FLR-95

EATON FULLER

CHELSEA®

FRLO-16410C-T2
FRLO-14410C-T2
FRLO-15410C-T2
FRLO-14410C
FRLO-15410C
FRLO-16410C

LEFT SIDE ONLY

RIGHT SIDE ONLY

TRANSMISSION GEAR DATA:

L.S. 06-BOLT Opening Gear FORWARD of Centerline
51 Teeth - R.H. HELIX

PITCH LINE TO APERTURE FACE:

1.0850" (27.5590MM)

TRANSMISSION GEAR DATA:

R.S. 06-BOLT Opening Gear FORWARD of Centerline
51 Teeth - R.H. HELIX

PITCH LINE TO APERTURE FACE:

1.0850" (27.5590MM)

CAUTION: Application Approval Required for PTO Output Shaft Speeds Above 2500 RPM

PTO Model	Torq I / C †	Dir Rot	Engine %		Filler Block	Adapter Assy	Stud Kit	PTO Model	Torq I / C †	Dir Rot	Engine %		Filler Block	Adapter Assy	Stud Kit
			Fwd	Rev							Fwd	Rev			
ONE SPEED - TWO GEAR - MECHANICAL SHIFT															
442GAJAX*5 (1)	250 I	Opp	43				Furnished	442GAJAX*3 (1)	250 I	Opp	43				Furnished
442GCJAX-*5 (8)	250 I	Opp	54				Furnished	442GCJAX-*3 (8)	250 I	Opp	54				Furnished
442GFJAX-*5 (3)	250 I	Opp	67				Furnished	442GFJAX-*3 (3)	250 I	Opp	67				Furnished
442GHJAX-*5 (4)	250 I	Opp	78				Furnished	442GHJAX-*3 (4)	250 I	Opp	78				Furnished
442GLJAX-*5 (1)	250 I	Opp	87				Furnished	442GLJAX-*3 (1)	250 I	Opp	87				Furnished
442GQJAX-*5 (1)	225 I	Opp	94				Furnished	442GQJAX-*3 (1)	225 I	Opp	94				Furnished
442GRJAX-*5 (1)	225 I	Opp	109				Furnished	442GRJAX-*3 (1)	225 I	Opp	109				Furnished
442GSJAX-*5 (1)	200 I	Opp	130				Furnished	442GSJAX-*3 (1)	200 I	Opp	130				Furnished
442GUJAX-*5 (1)	195 I	Opp	155				Furnished	442GUJAX-*3 (1)	195 I	Opp	155				Furnished
442GWJAX-*5 (1)	175 I	Opp	182				Furnished	442GWJAX-*3 (1)	175 I	Opp	182				Furnished
442GXJAX-*5 (1)	140 I	Opp	215				Furnished	442GXJAX-*3 (1)	140 I	Opp	215				Furnished
660GFJAX-*5 (5)	375 I	Opp	67				Furnished	660GFJAX-*3 (5)	375 I	Opp	67				Furnished
660GQJAX-*5 (6)	330 I	Opp	94				Furnished	660GQJAX-*3 (6)	330 I	Opp	94				Furnished
660GSJAX-*5 (7)	240 I	Opp	130				Furnished	660GSJAX-*3 (7)	240 I	Opp	130				Furnished
GEARED ADAPTERS															
626GJAX-4JC (2)	250 I	Eng					Furnished	626GJAX-3JC (2)	250 I	Eng					Furnished
630GJAX-4JC (2)	250 I	Eng					Furnished	630GJAX-3JC (2)	250 I	Eng					Furnished
								645GJAX-3JC (2)	250 I	Eng					Furnished

† I = Intermittent Torque Only - De-rate Torque Rating 30% for Continuous Duty.

C = Continuous or Intermittent Torque - No need to De-Rate Torque Rating.

IMPORTANT: Refer to the back of this transmission section and read all notes associated with this application page. Some notes may affect the proper PTO selection.

CAUTION: Eaton Transmission Division has established a MAXIMUM torque limit for the Transmission PTO driver gear. For all FR, FRO & FRLO transmissions the MAXIMUM torque limit for the transmission PTO driver gear is 750 lb-ft [678 Nm]. All torque limits on this application page reflect the 750 lb-ft [678 Nm] limit at the Transmission PTO driver gear. Refer to the Chelsea PTO Torque Limit Chart in the front section of this catalog for complete torque limit information.

CAUTION: Do not use geared adapters with 442 A and C ratios.

(1) Input Gear Part No. 5-P-1243
(2) Input Gear Part No. 5-P-1247
(3) Input Gear Part No. 5-P-1340
(4) Input Gear Part No. 5-P-1342
(5) Input Gear Part No. 5-P-1345

(6) Input Gear Part No. 5-P-1346
(7) Input Gear Part No. 5-P-1347
(8) Input Gear Part No. 5-P-1368

CHELSEA®

EATON FULLER

FLR-96LF

FSO-8209A (Left Side Forward Opening)
FSO-6109A (Left Forward)

LEFT SIDE ONLY

TRANSMISSION GEAR DATA:

L.F. 06-BOLT Opening Gear NON-STANDARD of Centerline
43 Teeth - R.H. HELIX

PITCH LINE TO APERTURE FACE:

2.9730" (75.5142MM)

CAUTION: Application Approval Required for PTO Output Shaft Speeds Above 2500 RPM

PTO Model	Torq	Dir Rot	Engine %		Filler Block	Adapter Assy	Stud Kit	PTO Model	Torq	Dir Rot	Engine %		Filler Block	Adapter Assy	Stud Kit
	I / C †		Fwd	Rev					I / C †		Fwd	Rev			

ONE SPEED - TWO GEAR - MECHANICAL SHIFT

442XFAHX-*5 (2)	250 I	Eng	113			329182-1X	Furnished
442XHAHX-*5 (3)	250 I	Eng	131			329182-1X	Furnished
442XLAHX-*5 (1)	250 I	Eng	146			329182-1X	Furnished
442XQAHX-*5 (1)	225 I	Eng	157			329182-1X	Furnished
442XRAHX-*5 (1)	225 I	Eng	182			329182-1X	Furnished
442XSAHX-*5 (1)	200 I	Eng	217			329182-1X	Furnished
442XUAHX-*5 (1)	195 I	Eng	258			329182-1X	Furnished
442XWAHX-*5 (1)	175 I	Eng	304			329182-1X	Furnished
442XXAHX-*5 (1)	140 I	Eng	359			329182-1X	Furnished
660XHAHX-*5 (3)	375 I	Eng	131			329182-1X	Furnished

ONE SPEED - TWO GEAR POWERSHIFT (AIR OR HYDRAULIC)

272XAAJX-*5 (4)	300 C	Eng	84			329182X	Furnished
272XBAJX-*5 (5)	300 C	Eng	104			329182X	Furnished
272XCAJX-*5 (6)	300 C	Eng	125			329182X	Furnished
272XGAJX-*5 (7)	300 C	Eng	178			329182X	Furnished
272XKAJX-*5 (8)	300 C	Eng	199			329182X	Furnished
272XMAJX-*5 (9)	300 C	Eng	223			329182X	Furnished
272XPAJX-*5 (10)	300 C	Eng	249			329182X	Furnished
272XSAJX-*5 (11)	300 C	Eng	278			329182X	Furnished

† I = Intermittent Torque Only - De-rate Torque Rating 30% for Continuous Duty.

C = Continuous or Intermittent Torque - No need to De-Rate Torque Rating.

IMPORTANT: Refer to the back of this transmission section and read all notes associated with this application page.
Some notes may affect the proper PTO selection.

- (1) Input Gear Part No. 5-P-1004 (6) Input Gear Part No. 5-P-1510-3X (11) Input Gear Part No. 5-P-1510-9X
(2) Input Gear Part No. 5-P-1077 (7) Input Gear Part No. 5-P-1510-5X
(3) Input Gear Part No. 5-P-1364 (8) Input Gear Part No. 5-P-1510-6X
(4) Input Gear Part No. 5-P-1510-1X (9) Input Gear Part No. 5-P-1510-7X
(5) Input Gear Part No. 5-P-1510-2X (10) Input Gear Part No. 5-P-1510-8X

FLR-97

EATON FULLER

CHELSEA®

FS-6406N
FS-6406N
F-6405-DM3
F-6406N-ASW
F-6406N-ASW
F-6406N-AW3
FO-6406N-AW3
F-6406N-ASX

LEFT SIDE ONLY

RIGHT SIDE ONLY

TRANSMISSION GEAR DATA:

L.S. 06-BOLT Opening Gear FORWARD of Centerline
39 Teeth - R.H. HELIX

PITCH LINE TO APERTURE FACE:

1.1600" (29.4640MM)

TRANSMISSION GEAR DATA:

R.S. 06-BOLT Opening Gear FORWARD of Centerline
39 Teeth - R.H. HELIX

PITCH LINE TO APERTURE FACE:

1.1600" (29.4640MM)

CAUTION: Application Approval Required for PTO Output Shaft Speeds Above 2500 RPM

PTO Model	Torq l / C †	Dir Rot	Engine %		Filler Block	Adapter Assy	Stud Kit	PTO Model	Torq l / C †	Dir Rot	Engine %		Filler Block	Adapter Assy	Stud Kit
			Fwd	Rev							Fwd	Rev			

ONE SPEED - TWO GEAR - MECHANICAL SHIFT

442XFJWX-*5 (2)	250 l	Opp	51				Furnished	442XFJWX-*3 (2)	250 l	Opp	51				Furnished
442XLJWX-*5 (1)	250 l	Opp	66				Furnished	442XLJWX-*3 (1)	250 l	Opp	66				Furnished
442XQJWX-*5 (1)	225 l	Opp	71				Furnished	442XQJWX-*3 (1)	225 l	Opp	71				Furnished
442XRJWX-*5 (1)	225 l	Opp	83				Furnished	442XRJWX-*3 (1)	225 l	Opp	83				Furnished
442XSJWX-*5 (1)	200 l	Opp	98				Furnished	442XSJWX-*3 (1)	200 l	Opp	98				Furnished
442XUJWX-*5 (1)	195 l	Opp	117				Furnished	442XUJWX-*3 (1)	195 l	Opp	117				Furnished
442XWJWX-*5 (1)	175 l	Opp	138				Furnished	442XWJWX-*3 (1)	175 l	Opp	138				Furnished
442XXJWX-*5 (1)	140 l	Opp	163				Furnished	442XXJWX-*3 (1)	140 l	Opp	163				Furnished

ONE SPEED - TWO GEAR POWERSHIFT (AIR OR HYDRAULIC)

272ZAJWX-*5 (4)	300 C	Opp	32				Furnished	272ZAJWX-*3 (4)	300 C	Opp	32				Furnished
272ZBJWX-*5 (5)	300 C	Opp	40				Furnished	272ZBJWX-*3 (5)	300 C	Opp	40				Furnished
272ZCJWX-*5 (6)	300 C	Opp	48				Furnished	272ZCJWX-*3 (6)	300 C	Opp	48				Furnished
272ZDJWX-*5 (7)	300 C	Opp	57				Furnished	272ZDJWX-*3 (7)	300 C	Opp	57				Furnished
272ZGJWX-*5 (8)	300 C	Opp	68				Furnished	272ZGJWX-*3 (8)	300 C	Opp	68				Furnished
272ZKJWX-*5 (9)	300 C	Opp	76				Furnished	272ZKJWX-*3 (9)	300 C	Opp	76				Furnished
272ZMJWX-*5 (10)	300 C	Opp	85				Furnished	272ZMJWX-*3 (10)	300 C	Opp	85				Furnished
272ZPJWX-*5 (11)	279 C	Opp	95				Furnished	272ZPJWX-*3 (11)	279 C	Opp	95				Furnished
272ZSJWX-*5 (12)	250 C	Opp	107				Furnished	272ZSJWX-*3 (12)	250 C	Opp	107				Furnished

ONE SPEED - FORWARD & REVERSE

340XFJWX-*5 (3)	200 l	Opp	46	49			Furnished	340XFJWX-*5 (3)	200 l	Opp	46	49			Furnished
-----------------	-------	-----	----	----	--	--	-----------	-----------------	-------	-----	----	----	--	--	-----------

GEARED ADAPTERS

626XJWX-4KB	250 l	Eng					Furnished	626XJWX-3KB	250 l	Eng					Furnished
630XJWX-4KB	250 l	Eng					Furnished	630XJWX-3KB	250 l	Eng					Furnished
645XJWX-4KB	250 l	Eng					Furnished	645XJWX-3KB	250 l	Eng					Furnished

† I = Intermittent Torque Only - De-rate Torque Rating 30% for Continuous Duty.

C = Continuous or Intermittent Torque - No need to De-Rate Torque Rating.

IMPORTANT: Refer to the back of this transmission section and read all notes associated with this application page. Some notes may affect the proper PTO selection.

CAUTION: The Eaton ASW, AW3, ASX & DM transmissions must have an input signal from the Power Take-Off when it is active. In this active state, the clutch engagement is controlled when the operator raises the engine speed to engage the clutch and drive the transmission main box countershaft. Minimum engine/transmission speed required for PTO operation is 1000 RPM, REFER to Eaton publication "TRIG-2600" for complete wiring information. INCORRECT or NO PTO interface signal to the transmission will result in uncontrolled engagement of the clutch during PTO operation.

- (1) Input Gear Part No. 5-P-1319 (6) Input Gear Part No. 5-P-1514-3X (11) Input Gear Part No. 5-P-1514-8X
 (2) Input Gear Part No. 5-P-1320 (7) Input Gear Part No. 5-P-1514-4X (12) Input Gear Part No. 5-P-1514-9X
 (3) Input Gear Part No. 5-P-1404 (8) Input Gear Part No. 5-P-1514-5X
 (4) Input Gear Part No. 5-P-1514-1X (9) Input Gear Part No. 5-P-1514-6X
 (5) Input Gear Part No. 5-P-1514-2X (10) Input Gear Part No. 5-P-1514-7X

CHELSEA®

EATON FULLER

FLR-100

RTO-10910B-DM2 (UltraShift) RTOM-16910B-DM3 (UltraShift)
 RTO-12910B-DM2 (UltraShift)
 RTO-14910B-DM2 (UltraShift)
 RTO-16910B-DM2 (UltraShift)
 RTO-10910B-DM3 (UltraShift)
 RTO-12910B-DM3 (UltraShift)
 RTO-14910B-DM3 (UltraShift)
 RTO-16910B-DM3 (UltraShift)

BOTTOM SIDE ONLY

RIGHT SIDE ONLY

TRANSMISSION GEAR DATA:

BOT 08-BOLT Opening Gear FORWARD of Centerline
 47 Teeth - SPUR

PITCH LINE TO APERTURE FACE:

0.8050" (20.4500MM)

TRANSMISSION GEAR DATA:

R.S. 06-BOLT Opening Gear FORWARD of Centerline
 45 Teeth - SPUR

PITCH LINE TO APERTURE FACE:

1.0850" (27.5600MM)

CAUTION: Application Approval Required for PTO Output Shaft Speeds Above 2500 RPM

PTO Model	Torq I / C †	Dir Rot	Engine %		Filler Block	Adapter Assy	Stud Kit	PTO Model	Torq I / C †	Dir Rot	Engine %		Filler Block	Adapter Assy	Stud Kit
			Fwd	Rev							Fwd	Rev			

ONE SPEED - TWO GEAR - MECHANICAL SHIFT

221ZCAHX-*3	250 I	Opp	82	7-A-032(P)(43)	328564X	Furnished	221XCAHX-*3	250 I	Opp	79	7-A-032(43)	Furnished
221ZEAHX-*3	250 I	Opp	95		328564X	Furnished	221XEAHX-*3	250 I	Opp	91		Furnished
489XAAHX-*5 (12)	250 I	Opp	72			Furnished	442XAAHX-*3 (12)	250 I	Opp	69		Furnished
489XCAHX-*5 (13)	250 I	Opp	93			Furnished	442XBAHX-*3 (18)	250 I	Eng	69	REQUIRED	Furnished
489XFAHX-*5 (2)	250 I	Opp	114			Furnished	442XCAHX-*3 (13)	250 I	Opp	89		Furnished
489XHAHX-*5 (15)	250 I	Opp	132			Furnished	442XFAHX-*3 (2)	250 I	Opp	110		Furnished
489XLAHX-*5 (1)	222 I	Opp	148			Furnished	442XHAHX-*3 (15)	250 I	Opp	127		Furnished
489XQAHX-*5 (1)	206 I	Opp	160			Furnished	442XLAHX-*3 (1)	233 I	Opp	142		Furnished
489XRAHX-*5 (1)	178 I	Opp	185			Furnished	442XQAHX-*3 (1)	216 I	Opp	153		Furnished
489XSAHX-*5 (1)	150 I	Opp	220			Furnished	442XRAHX-*3 (1)	187 I	Opp	177		Furnished
489XUAHX-*5 (1)	126 I	Opp	262			Furnished	442XSAHX-*3 (1)	156 I	Opp	211		Furnished
489XWAHX-*5 (1)	107 I	Opp	308			Furnished	442XUAHX-*3 (1)	132 I	Opp	251		Furnished
489XXAHX-*5 (1)	91 I	Opp	365			Furnished	442XWAHX-*3 (1)	112 I	Opp	295		Furnished
680XFAHX-*3 (10)	288 I	Opp	114			Furnished	442XXAHX-*3 (1)	94 I	Opp	349		Furnished
680XHAHX-*3 (20)	249 I	Opp	132			Furnished	660XFAHX-*3 (10)	301 I	Opp	110		Furnished
680XQAHX-*3 (11)	206 I	Opp	160			Furnished	660XHAHX-*3 (15)	260 I	Opp	127		Furnished
680XRAHX-*3 (19)	178 I	Opp	185			Furnished	660XQAHX-*3 (11)	216 I	Opp	153		Furnished
680XSAHX-*3 (14)	150 I	Opp	220			Furnished	660XRAHX-*3 (19)	187 I	Opp	177		Furnished
823XBAHX-*3 (37)	423 I	Opp	78			Furnished	660XSAHX-*3 (14)	156 I	Opp	211		Furnished
823XDAHX-*3 (41)	357 I	Opp	92			Furnished						
823XGAHX-*3 (42)	329 I	Opp	100			Furnished						
823XJAHX-*3 (38)	279 I	Opp	118			Furnished						
823XMAHX-*3 (36)	238 I	Opp	139			Furnished						
823XRAHX-*3 (40)	172 I	Opp	191			Furnished						
823XTKTX-*3 (17)	142 I	Opp	231	8-A-165(43)		Furnished						
880XBAHX-*3 (3)	423 I	Opp	78			Furnished						
880XDAHX-*3 (4)	357 I	Opp	92			Furnished						
880XGAHX-*3 (9)	329 I	Opp	100			Furnished						
880XJAHX-*3 (5)	279 I	Opp	118			Furnished						
880XMAHX-*3 (6)	238 I	Opp	139			Furnished						
880XQAHX-*3 (16)	203 I	Opp	162			Furnished						

Continued on Next Page

† I = Intermittent Torque Only - De-rate Torque Rating 30% for Continuous Duty.

C = Continuous or Intermittent Torque - No need to De-Rate Torque Rating.

IMPORTANT: Refer to the back of this transmission section and read all notes associated with this application page. Some notes may affect the proper PTO selection.

CAUTION: Eaton Transmission Division has established a Maximum Torque Limit for the Transmission PTO Driver Gear. For all RT/RTO/RTLO transmissions the torque limit is 350 lb-ft [475 Nm] unless the transmission has been upgraded to a roller type input shaft bearing, Eaton part number 4301417, then 750 lb-ft [1017 Nm] torque becomes the Maximum limit. All torque limits on this application page reflect the 350 lb-ft [475 Nm] limit at the Transmission PTO Drive Gear. Refer to the Chelsea PTO Torque Limit Chart in the front of this section for complete torque limit information.

CAUTION: DO NOT use geared adapters with 442 A and C ratios.

(1) Input Gear Part No. 5-P-1004	(6) Input Gear Part No. 5-P-1103	(13) Input Gear Part No. 5-P-1287	(18) Input Gear Part No. 5-P-1418	(38) Input Gear Part No. 5-P-325
(2) Input Gear Part No. 5-P-1077	(9) Input Gear Part No. 5-P-1135	(14) Input Gear Part No. 5-P-1322	(19) Input Gear Part No. 5-P-1441	(40) Input Gear Part No. 5-P-721
(3) Input Gear Part No. 5-P-1100	(10) Input Gear Part No. 5-P-1242	(15) Input Gear Part No. 5-P-1364	(20) Input Gear Part No. 5-P-1494	(41) Input Gear Part No. 5-P-971
(4) Input Gear Part No. 5-P-1101	(11) Input Gear Part No. 5-P-1246	(16) Input Gear Part No. 5-P-1385	(36) Input Gear Part No. 5-P-283	(42) Input Gear Part No. 5-P-980
(5) Input Gear Part No. 5-P-1102	(12) Input Gear Part No. 5-P-1280	(17) Input Gear Part No. 5-P-1395	(37) Input Gear Part No. 5-P-285	(43) Filler block furnished with PTO

FLR-100

EATON FULLER

CHELSEA®

RTO-10910B-DM2 (UltraShift) RTOM-16910B-DM3 (UltraShift)
 RTO-12910B-DM2 (UltraShift)
 RTO-14910B-DM2 (UltraShift)
 RTO-16910B-DM2 (UltraShift)
 RTO-10910B-DM3 (UltraShift)
 RTO-12910B-DM3 (UltraShift)
 RTO-14910B-DM3 (UltraShift)
 RTO-16910B-DM3 (UltraShift)

BOTTOM SIDE ONLY

RIGHT SIDE ONLY

TRANSMISSION GEAR DATA:

BOT 08-BOLT Opening Gear FORWARD of Centerline
 47 Teeth - SPUR

PITCH LINE TO APERTURE FACE:

0.8050" (20.4500MM)

TRANSMISSION GEAR DATA:

R.S. 06-BOLT Opening Gear FORWARD of Centerline
 45 Teeth - SPUR

PITCH LINE TO APERTURE FACE:

1.0850" (27.5600MM)

CAUTION: Application Approval Required for PTO Output Shaft Speeds Above 2500 RPM

PTO Model	Torq I / C †	Dir Rot	Engine %		Filler Block	Adapter Assy	Stud Kit	PTO Model	Torq I / C †	Dir Rot	Engine %		Filler Block	Adapter Assy	Stud Kit
			Fwd	Rev							Fwd	Rev			

ONE SPEED - TWO GEAR - MECHANICAL SHIFT

880XRAHX-*3 (7)	172 I	Opp	191				Furnished								
880XTAHX-*3 (8)	134 I	Opp	246				Furnished								

ONE SPEED - TWO GEAR POWERSHIFT (AIR OR HYDRAULIC)

272XAAJX-*3 (30)	300 C	Opp	64			328481X	Furnished	272XAAJX-*3 (30)	300 C	Opp	61				Furnished
282XBAJX-*3 (21)	300 C	Opp	78		8-A-032		Furnished	272XBAJX-*3 (31)	300 C	Opp	75				Furnished
282XCAJX-*3 (22)	300 C	Opp	94		8-A-032		Furnished	272XCAJX-*3 (32)	300 C	Opp	90				Furnished
282XDAJX-*3 (23)	293 C	Opp	113		8-A-032		Furnished	272XDAJX-*3 (33)	300 C	Opp	108				Furnished
282XGAJX-*3 (24)	246 C	Opp	134		8-A-032		Furnished	272XGAJX-*3 (34)	257 C	Opp	128				Furnished
282XKAJX-*3 (25)	220 C	Opp	150		8-A-032		Furnished	272XKAJX-*3 (35)	230 C	Opp	144				Furnished
282XMAJX-*3 (26)	197 C	Opp	168		8-A-032		Furnished	272XMAJX-*3 (36)	206 C	Opp	161				Furnished
282XPAJX-*3 (27)	176 C	Opp	180		8-A-032		Furnished	272XPAJX-*3 (37)	184 C	Opp	180				Furnished
282XSAJX-*3 (28)	158 C	Opp	210		8-A-032		Furnished	272XSAJX-*3 (38)	165 C	Opp	201				Furnished
282XTAJX-*3 (29)	141 C	Opp	235		8-A-032		Furnished								

ONE SPEED - TWO GEAR - POWERSHIFT (AIR)

885XBAHX-*3 (3)	423 I	Opp	78				Furnished								
885XGAHX-*3 (9)	329 I	Opp	100				Furnished								
885XJAHX-*3 (5)	279 I	Opp	118				Furnished								
885XMAHX-*3 (6)	238 I	Opp	139				Furnished								

ONE SPEED - FORWARD & REVERSE

348XFAHX-*5 (39)	200 I	Opp	100	105			Furnished	340XFAHX-*5 (39)	200 I	Opp	96	101	7-A-140(43)		Furnished
863XBAHX-*5	423 I	Opp	78	97			Furnished								

GEARED ADAPTERS

626XAHX-3AH	250 I	Eng			8-A-032		Furnished	626XAHX-3AH	250 I	Eng					Furnished
								630-02	250 I	Eng					Furnished
								630XAHX-3AH	250 I	Eng					Furnished
								645XAHX-3AH	250 I	Eng					Furnished

Continued on Next Page

† I = Intermittent Torque Only - De-rate Torque Rating 30% for Continuous Duty.

C = Continuous or Intermittent Torque - No need to De-Rate Torque Rating.

IMPORTANT: Refer to the back of this transmission section and read all notes associated with this application page.

CAUTION: Eaton Transmission Division has established a Maximum Torque Limit for the Transmission PTO Driver Gear. For all RT/RTO/RTLO transmissions the torque limit is 350 lb-ft [475 Nm] unless the transmission has been upgraded to a roller type input shaft bearing, Eaton part number 4301417, then 750 lb-ft [1017 Nm] torque becomes the Maximum limit. All torque limits on this application page reflect the 350 lb-ft [475 Nm] limit at the Transmission PTO Drive Gear. Refer to the Chelsea PTO Torque Limit Chart in the front of this section for complete torque limit information.

CAUTION: DO NOT use geared adapters with 442 A and C ratios.

(3) Input Gear Part No. 5-P-1100	(21) Input Gear Part No. 5-P-1510-11X	(27) Input Gear Part No. 5-P-1510-17X	(33) Input Gear Part No. 5-P-1510-4X	(38) Input Gear Part No. 5-P-1510-9X
(5) Input Gear Part No. 5-P-1102	(22) Input Gear Part No. 5-P-1510-12X	(28) Input Gear Part No. 5-P-1510-18X	(34) Input Gear Part No. 5-P-1510-5X	(39) Input Gear Part No. 5-P-581
(6) Input Gear Part No. 5-P-1103	(23) Input Gear Part No. 5-P-1510-13X	(29) Input Gear Part No. 5-P-1510-19X	(35) Input Gear Part No. 5-P-1510-6X	(43) Filler block furnished with PTO
(7) Input Gear Part No. 5-P-1104	(24) Input Gear Part No. 5-P-1510-14X	(30) Input Gear Part No. 5-P-1510-1X	(36) Input Gear Part No. 5-P-1510-7X	
(8) Input Gear Part No. 5-P-1105	(25) Input Gear Part No. 5-P-1510-15X	(31) Input Gear Part No. 5-P-1510-2X	(37) Input Gear Part No. 5-P-1510-8X	
(9) Input Gear Part No. 5-P-1135	(26) Input Gear Part No. 5-P-1510-16X	(32) Input Gear Part No. 5-P-1510-3X		

CHELSEA®

EATON FULLER

FLR-100

RTO-10910B-DM2 (UltraShift) RTOM-16910B-DM3 (UltraShift)
 RTO-12910B-DM2 (UltraShift)
 RTO-14910B-DM2 (UltraShift)
 RTO-16910B-DM2 (UltraShift)
 RTO-10910B-DM3 (UltraShift)
 RTO-12910B-DM3 (UltraShift)
 RTO-14910B-DM3 (UltraShift)
 RTO-16910B-DM3 (UltraShift)

REAR SIDE ONLY**TRANSMISSION GEAR DATA:**

REAR 00-BOLT Opening

PITCH LINE TO APERTURE FACE:**CAUTION: Application Approval Required for PTO Output Shaft Speeds Above 2500 RPM**

PTO Model	Torq	Dir Rot	Engine %		Filler Block	Adapter Assy	Stud Kit	PTO Model	Torq	Dir Rot	Engine %		Filler Block	Adapter Assy	Stud Kit
	I / C †		Fwd	Rev					I / C †		Fwd	Rev			

REAR MOUNT - "AU" MOUNTING OPTION

541-LAU-*.*	400 I	Eng	91				Furnished
541-MAU-*.*	350 I	Eng	117				Furnished
541-NAU-*.*	300 I	Eng	133				Furnished

† I = Intermittent Torque Only - De-rate Torque Rating 30% for Continuous Duty.

C = Continuous or Intermittent Torque - No need to De-Rate Torque Rating.

IMPORTANT: Refer to the back of this transmission section and read all notes associated with this application page. Some notes may affect the proper PTO selection.

CAUTION: Eaton Transmission Division has established a Maximum Torque Limit for the Transmission PTO Driver Gear. For all RT/RTO/RTLO transmissions the torque limit is 350 lb-ft [475 Nm] unless the transmission has been upgraded to a roller type input shaft bearing, Eaton part number 4301417, then 750 lb-ft [1017 Nm] torque becomes the Maximum limit. All torque limits on this application page reflect the 350 lb-ft [475 Nm] limit at the Transmission PTO Drive Gear. Refer to the Chelsea PTO Torque Limit Chart in the front of this section for complete torque limit information.

CAUTION: DO NOT use geared adapters with 442 A and C ratios.

Eaton Fuller

FLR-105

EATON FULLER



FA-11810B (Advantage Series) ThruShaft use AV mounting
FA-12610B (Advantage Series) ThruShaft use AV mounting
FA-13810B (Advantage Series) ThruShaft use AV mounting
FA-14810B (Advantage Series) ThruShaft use AV mounting
FA-15810B (Advantage Series) ThruShaft use AV mounting
FA-9810B (Advantage Series) ThruShaft use AV mounting
FAF-11810B (Advantage Series) ThruShaft use AV mounting
FAF-12810B (Advantage Series) ThruShaft use AV mounting

FAF-13810B (Advantage Series) ThruShaft use AV mounting
FAF-14810B (Advantage Series) ThruShaft use AV mounting
FAF-15810B (Advantage Series) ThruShaft use AV mounting
FAF-9810B (Advantage Series) ThruShaft use AV mounting
FAM-14810B (Advantage Series) ThruShaft use AV mounting
FAM-14810B-EA3 (Advantage Series Automated) ThruShaft use AV mounting
FAM-15810B (Advantage Series) ThruShaft use AV mounting
FAM-15810B-EA3 (Advantage Series Automated) ThruShaft use AV mounting

FAMF-14810B (Advantage Series) ThruShaft use AV mounting
FAMF-15810B (Advantage Series) ThruShaft use AV mounting

BOTTOM SIDE ONLY

RIGHT SIDE ONLY

TRANSMISSION GEAR DATA:

BOT 08-BOLT Opening Gear FORWARD of Centerline
47 Teeth - SPUR

PITCH LINE TO APERTURE FACE:

0.8050" (20.4500MM)

TRANSMISSION GEAR DATA:

R.S. 06-BOLT Opening Gear FORWARD of Centerline
45 Teeth - SPUR

PITCH LINE TO APERTURE FACE:

1.0850" (27.5600MM)

CAUTION: Application Approval Required for PTO Output Shaft Speeds Above 2500 RPM

PTO Model	Torq I / C †	Dir Rot	Engine %		Filler Block	Adapter Assy	Stud Kit	PTO Model	Torq I / C †	Dir Rot	Engine %		Filler Block	Adapter Assy	Stud Kit
			Fwd	Rev							Fwd	Rev			

ONE SPEED - TWO GEAR - MECHANICAL SHIFT

221ZCAHX-*3	250 I	Opp	61		7-A-032(P)(46)	328564X	Furnished	221XCAHX-*3	250 I	Opp	58		7-A-032(46)		Furnished
221ZEAHX-*3	250 I	Opp	70			328564X	Furnished	221XEAHX-*3	250 I	Opp	67				Furnished
489XAAHX-*5 (12)	250 I	Opp	54				Furnished	442XAAHX-*3 (12)	250 I	Opp	51				Furnished
489XCAHX-*5 (13)	250 I	Opp	69				Furnished	442XBAHX-*3 (18)	250 I	Eng	51		REQUIRED		Furnished
489XFAHX-*5 (2)	250 I	Opp	85				Furnished	442XCAHX-*3 (13)	250 I	Opp	66				Furnished
489XHAHX-*5 (15)	250 I	Opp	99				Furnished	442XFAHX-*3 (2)	250 I	Opp	81				Furnished
489XLAHX-*5 (1)	250 I	Opp	110				Furnished	442XHAHX-*3 (15)	250 I	Opp	94				Furnished
489XQAHX-*5 (1)	225 I	Opp	118				Furnished	442XLAHX-*3 (1)	250 I	Opp	105				Furnished
489XRAHX-*5 (1)	225 I	Opp	137				Furnished	442XQAHX-*3 (1)	225 I	Opp	113				Furnished
489XSAHX-*5 (1)	200 I	Opp	163				Furnished	442XRAHX-*3 (1)	225 I	Opp	131				Furnished
489XUAHX-*5 (1)	195 I	Opp	194				Furnished	442XSAHX-*3 (1)	200 I	Opp	156				Furnished
489XWAHX-*5 (1)	175 I	Opp	229				Furnished	442XUAHX-*3 (1)	195 I	Opp	186				Furnished
489XXAHX-*5 (1)	140 I	Opp	271				Furnished	442XWAHX-*3 (1)	175 I	Opp	219				Furnished
680XFAHX-*3 (10)	375 I	Opp	85				Furnished	442XXAHX-*3 (1)	140 I	Opp	259				Furnished
680XHAHX-*3 (20)	375 I	Opp	99				Furnished	660XFAHX-*3 (10)	375 I	Opp	81				Furnished
680XQAHX-*3 (11)	375 I	Opp	118				Furnished	660XHAHX-*3 (15)	375 I	Opp	94				Furnished
680XRAHX-*3 (19)	350 I	Opp	137				Furnished	660XQAHX-*3 (11)	375 I	Opp	113				Furnished
680XSAHX-*3 (14)	322 I	Opp	163				Furnished	660XRAHX-*3 (19)	350 I	Opp	131				Furnished
823XBAHX-*3 (44)	750 I	Opp	58				Furnished	660XSAHX-*3 (14)	336 I	Opp	156				Furnished
823XDAHX-*3 (40)	750 I	Opp	69				Furnished								
823XGAHX-*3 (45)	705 I	Opp	74				Furnished								
823XJAHX-*3 (41)	599 I	Opp	88				Furnished								
823XMAHX-*3 (39)	511 I	Opp	103				Furnished								
823XRAHX-*3 (43)	370 I	Opp	142				Furnished								
823XTKTX-*3 (17)	305 I	Opp	172		8-A-165(46)		Furnished								
880XBAHX-*3 (3)	500 I	Opp	58				Furnished								
880XDAHX-*3 (4)	500 I	Opp	69				Furnished								
880XGAHX-*3 (9)	500 I	Opp	74				Furnished								
880XJAHX-*3 (5)	500 I	Opp	88				Furnished								
880XMAHX-*3 (6)	500 I	Opp	103				Furnished								
880XQAHX-*3 (16)	435 I	Opp	120				Furnished								

Continued on Next Page

† I = Intermittent Torque Only - De-rate Torque Rating 30% for Continuous Duty.

C = Continuous or Intermittent Torque - No need to De-Rate Torque Rating.

IMPORTANT: Refer to the back of this transmission section and read all notes associated with this application page. Some notes may affect the proper PTO selection.

CAUTION: INPUT SIGNAL REQUIRED: In any case a PTO is used, regardless of PTO style, the transmission must have an input signal from the PTO when it is active. Eaton requires the OEM to provide a "PTO Active" input connection to the transmission ECU. Refer to the Vehicle OEM for wire connection information and to EATON TRIG2600 for Transmission/PTO Operations.

CAUTION: DO NOT use geared adapters with 442 A and C ratios.

- | | | | | |
|----------------------------------|-----------------------------------|-----------------------------------|-----------------------------------|--------------------------------------|
| (1) Input Gear Part No. 5-P-1004 | (6) Input Gear Part No. 5-P-1103 | (13) Input Gear Part No. 5-P-1287 | (18) Input Gear Part No. 5-P-1418 | (41) Input Gear Part No. 5-P-325 |
| (2) Input Gear Part No. 5-P-1077 | (9) Input Gear Part No. 5-P-1135 | (14) Input Gear Part No. 5-P-1322 | (19) Input Gear Part No. 5-P-1441 | (43) Input Gear Part No. 5-P-721 |
| (3) Input Gear Part No. 5-P-1100 | (10) Input Gear Part No. 5-P-1242 | (15) Input Gear Part No. 5-P-1364 | (20) Input Gear Part No. 5-P-1494 | (44) Input Gear Part No. 5-P-971 |
| (4) Input Gear Part No. 5-P-1101 | (11) Input Gear Part No. 5-P-1246 | (16) Input Gear Part No. 5-P-1385 | (39) Input Gear Part No. 5-P-283 | (45) Input Gear Part No. 5-P-980 |
| (5) Input Gear Part No. 5-P-1102 | (12) Input Gear Part No. 5-P-1280 | (17) Input Gear Part No. 5-P-1395 | (40) Input Gear Part No. 5-P-285 | (46) Filler block furnished with PTO |

Eaton Fuller



October 2022
5.5.68

Parker Hannifin Corporation
Chelsea Products Division
Olive Branch, MS 38654 USA

FA-11810B (Advantage Series) ThruShaft use AV mounting
FA-12810B (Advantage Series) ThruShaft use AV mounting
FA-13810B (Advantage Series) ThruShaft use AV mounting
FA-14810B (Advantage Series) ThruShaft use AV mounting
FA-15810B (Advantage Series) ThruShaft use AV mounting
FA-9810B (Advantage Series) ThruShaft use AV mounting
FAF-11810B (Advantage Series) ThruShaft use AV mounting
FAF-12810B (Advantage Series) ThruShaft use AV mounting

FAF-13810B (Advantage Series) ThruShaft use AV mounting
FAF-14810B (Advantage Series) ThruShaft use AV mounting
FAF-15810B (Advantage Series) ThruShaft use AV mounting
FAF-9810B (Advantage Series) ThruShaft use AV mounting
FAM-14810B (Advantage Series) ThruShaft use AV mounting
FAM-14810B-EA3 (Advantage Series Automated) ThruShaft use AV mounting
FAM-15810B (Advantage Series) ThruShaft use AV mounting
FAM-15810B-EA3 (Advantage Series Automated) ThruShaft use AV mounting

FAMF-14810B (Advantage Series) ThruShaft use AV mounting
FAMF-15810B (Advantage Series) ThruShaft use AV mounting

BOTTOM SIDE ONLY

RIGHT SIDE ONLY

TRANSMISSION GEAR DATA:

BOT 08-BOLT Opening Gear FORWARD of Centerline
47 Teeth - SPUR

PITCH LINE TO APERTURE FACE:

0.8050" (20.4500MM)

TRANSMISSION GEAR DATA:

R.S. 06-BOLT Opening Gear FORWARD of Centerline
45 Teeth - SPUR

PITCH LINE TO APERTURE FACE:

1.0850" (27.5600MM)

CAUTION: Application Approval Required for PTO Output Shaft Speeds Above 2500 RPM

PTO Model	Torq I / C †	Dir Rot	Engine %		Filler Block	Adapter Assy	Stud Kit	PTO Model	Torq I / C †	Dir Rot	Engine %		Filler Block	Adapter Assy	Stud Kit
			Fwd	Rev							Fwd	Rev			

ONE SPEED - TWO GEAR - MECHANICAL SHIFT

880XRAHX-*3 (7)	370 I	Opp	142												Furnished
880XTAHX-*3 (8)	287 I	Opp	183												Furnished

ONE SPEED - TWO GEAR POWERSHIFT (AIR OR HYDRAULIC)

272XAAJX-*3 (30)	300 C	Opp	47			328481X	Furnished	272XAAJX-*3 (30)	300 C	Opp	45					Furnished
282XBAJX-*3 (21)	300 C	Opp	58		8-A-032		Furnished	272XBAJX-*3 (31)	300 C	Opp	55					Furnished
282XCAJX-*3 (22)	300 C	Opp	70		8-A-032		Furnished	272XCAJX-*3 (32)	300 C	Opp	67					Furnished
282XDAJX-*3 (23)	300 C	Opp	84		8-A-032		Furnished	272XDAJX-*3 (33)	300 C	Opp	80					Furnished
282XGAJX-*3 (24)	300 C	Opp	100		8-A-032		Furnished	272XGAJX-*3 (34)	300 C	Opp	95					Furnished
282XKAJX-*3 (25)	300 C	Opp	111		8-A-032		Furnished	272XKAJX-*3 (35)	300 C	Opp	107					Furnished
282XMAJX-*3 (26)	300 C	Opp	124		8-A-032		Furnished	272XMAJX-*3 (36)	300 C	Opp	119					Furnished
282XPAJX-*3 (27)	300 C	Opp	139		8-A-032		Furnished	272XPAJX-*3 (37)	300 C	Opp	133					Furnished
282XSAJX-*3 (28)	300 C	Opp	156		8-A-032		Furnished	272XSAJX-*3 (38)	300 C	Opp	149					Furnished
282XTAJX-*3 (29)	300 C	Opp	174		8-A-032		Furnished									

ONE SPEED - TWO GEAR - POWERSHIFT (AIR)

885XBAHX-*3 (3)	500 I	Opp	58				Furnished									Furnished
885XGAHX-*3 (9)	500 I	Opp	74				Furnished									Furnished
885XJAHX-*3 (5)	500 I	Opp	88				Furnished									Furnished
885XMAHX-*3 (6)	500 I	Opp	103				Furnished									Furnished

ONE SPEED - FORWARD & REVERSE

348XFAHX-*5 (42)	200 I	Opp	74	78			Furnished	340XFAHX-*5 (42)	200 I	Opp	71	75	7-A-140(46)			Furnished
352ZSAHX-*3 (1)	140 I	Opp	165	214		328564X	Furnished	352ZSAHX-*3 (1)	140 I	Opp	158	205				Furnished
863XBAHX-*5	423 I	Opp	58	72			Furnished									

GEARED ADAPTERS

628XAHX-4AH	250 I	Eng			8-A-032		Furnished	626XAHX-3AH	250 I	Eng						Furnished
								630-02	250 I	Eng						Furnished
								630XAHX-3AH	250 I	Eng						Furnished
								645XAHX-3AH	250 I	Eng						Furnished

Continued on Next Page

† I = Intermittent Torque Only - De-rate Torque Rating 30% for Continuous Duty.

C = Continuous or Intermittent Torque - No need to De-Rate Torque Rating.

IMPORTANT: Refer to the back of this transmission section and read all notes associated with this application page. Some notes may affect the proper PTO selection.

CAUTION: INPUT SIGNAL REQUIRED: In any case a PTO is used, regardless of PTO style, the transmission must have an input signal from the PTO when it is active. Eaton requires the OEM to provide a "PTO Active" input connection to the transmission ECU. Refer to the Vehicle OEM for wire connection information and to EATON TRIG2600 for Transmission/PTO Operations.

- (1) Input Gear Part No. 5-P-1004
- (3) Input Gear Part No. 5-P-1100
- (5) Input Gear Part No. 5-P-1102
- (6) Input Gear Part No. 5-P-1103
- (7) Input Gear Part No. 5-P-1104
- (8) Input Gear Part No. 5-P-1105
- (9) Input Gear Part No. 5-P-1135
- (21) Input Gear Part No. 5-P-1510-11X
- (22) Input Gear Part No. 5-P-1510-12X
- (23) Input Gear Part No. 5-P-1510-13X
- (24) Input Gear Part No. 5-P-1510-14X
- (25) Input Gear Part No. 5-P-1510-15X
- (26) Input Gear Part No. 5-P-1510-16X
- (27) Input Gear Part No. 5-P-1510-17X
- (28) Input Gear Part No. 5-P-1510-18X
- (29) Input Gear Part No. 5-P-1510-19X
- (30) Input Gear Part No. 5-P-1510-1X
- (31) Input Gear Part No. 5-P-1510-2X
- (32) Input Gear Part No. 5-P-1510-3X
- (33) Input Gear Part No. 5-P-1510-4X
- (34) Input Gear Part No. 5-P-1510-5X
- (35) Input Gear Part No. 5-P-1510-6X
- (36) Input Gear Part No. 5-P-1510-7X
- (37) Input Gear Part No. 5-P-1510-8X
- (38) Input Gear Part No. 5-P-1510-9X
- (42) Input Gear Part No. 5-P-581
- (46) Filler block furnished with PTO

FLR-106

EATON FULLER

CHELSEA®

FO-10E308LL-VCS (UltraShift Plus) Thrustshaft use BD mounting
FO-11E308LL-VCS (UltraShift Plus) Thrustshaft use BD mounting
FO-12E308LL-VCS (UltraShift Plus) Thrustshaft use BD mounting
FO-14E308LL-VCS (UltraShift Plus) Thrustshaft use BD mounting
FO-16E308LL-VCS (UltraShift Plus) Thrustshaft use BD mounting
FO-17E308LL-VCS (UltraShift Plus) Thrustshaft use BD Mounting

BOTTOM SIDE ONLY

RIGHT SIDE ONLY

TRANSMISSION GEAR DATA:

BOT 08-BOLT Opening Gear FORWARD of Centerline
47 Teeth - SPUR

PITCH LINE TO APERTURE FACE:

0.8050" (20.4500MM)

TRANSMISSION GEAR DATA:

R.S. 06-BOLT Opening Gear FORWARD of Centerline
45 Teeth - SPUR

PITCH LINE TO APERTURE FACE:

1.0850" (27.5600MM)

CAUTION: Application Approval Required for PTO Output Shaft Speeds Above 2500 RPM

PTO Model	Torq I / C †	Dir Rot	Engine %		Filler Block	Adapter Assy	Stud Kit	PTO Model	Torq I / C †	Dir Rot	Engine %		Filler Block	Adapter Assy	Stud Kit
			Fwd	Rev							Fwd	Rev			

ONE SPEED - TWO GEAR - MECHANICAL SHIFT

221ZCAHX-*3	250 I	Opp	82		7-A-032(P)(45)	328564X	Furnished	221XCAHX-*3	250 I	Opp	79		7-A-032(45)		Furnished
221ZEAHX-*3	250 I	Opp	95			328564X	Furnished	221XEAHX-*3	250 I	Opp	91				Furnished
489XAAHX-*5 (11)	250 I	Opp	72				Furnished	442XAAHX-*3 (11)	250 I	Opp	69				Furnished
489XCAHX-*5 (12)	250 I	Opp	93				Furnished	442XBAHX-*3 (17)	250 I	Eng	69		REQUIRED		Furnished
489XFAHX-*5 (2)	250 I	Opp	114				Furnished	442XCAHX-*3 (12)	250 I	Opp	89				Furnished
489XHAHX-*5 (14)	250 I	Opp	132				Furnished	442XFAHX-*3 (2)	250 I	Opp	110				Furnished
489XLAHX-*5 (1)	250 I	Opp	148				Furnished	442XHAHX-*3 (14)	250 I	Opp	127				Furnished
489XQAHX-*5 (1)	225 I	Opp	160				Furnished	442XLAHX-*3 (1)	250 I	Opp	142				Furnished
489XRAHX-*5 (1)	220 I	Opp	185				Furnished	442XQAHX-*3 (1)	225 I	Opp	153				Furnished
489XSAHX-*5 (1)	155 I	Opp	220				Furnished	442XRAHX-*3 (1)	225 I	Opp	177				Furnished
489XUAHX-*5 (1)	110 I	Opp	262				Furnished	442XSAHX-*3 (1)	170 I	Opp	211				Furnished
489XWAHX-*5 (1)	80 I	Opp	308				Furnished	442XUAHX-*3 (1)	120 I	Opp	251				Furnished
489XXAHX-*5 (1)	55 I	Opp	365				Furnished	442XWAHX-*3 (1)	87 I	Opp	295				Furnished
680XFAHX-*3 (9)	375 I	Opp	114				Furnished	442XXAHX-*3 (1)	62 I	Opp	349				Furnished
680XHAHX-*3 (19)	375 I	Opp	132				Furnished	660XFAHX-*3 (9)	375 I	Opp	110				Furnished
680XQAHX-*3 (10)	295 I	Opp	160				Furnished	660XHAHX-*3 (14)	375 I	Opp	127				Furnished
680XRAHX-*3 (18)	220 I	Opp	185				Furnished	660XQAHX-*3 (10)	320 I	Opp	153				Furnished
680XSAHX-*3 (13)	155 I	Opp	220				Furnished	660XRAHX-*3 (18)	240 I	Opp	177				Furnished
823XBAHX-*3 (39)	750 I	Opp	78				Furnished	660XSAHX-*3 (13)	170 I	Opp	211				Furnished
823XDAHX-*3 (43)	750 I	Opp	92				Furnished								
823XGAHX-*3 (44)	705 I	Opp	100				Furnished								
823XJAHX-*3 (40)	599 I	Opp	118				Furnished								
823XMAHX-*3 (38)	511 I	Opp	139				Furnished								
823XRAHX-*3 (42)	370 I	Opp	191				Furnished								
823XTKTX-*3 (16)	305 I	Opp	231		8-A-165(45)		Furnished								
880XBAHX-*3 (3)	500 I	Opp	78				Furnished								
880XDAHX-*3 (4)	500 I	Opp	92				Furnished								
880XGAHX-*3 (8)	500 I	Opp	100				Furnished								
880XJAHX-*3 (5)	500 I	Opp	118				Furnished								
880XMAHX-*3 (6)	340 I	Opp	139				Furnished								
880XQAHX-*3 (15)	280 I	Opp	162				Furnished								
880XRAHX-*3 (7)	205 I	Opp	191				Furnished								

Continued on Next Page

† I = Intermittent Torque Only - De-rate Torque Rating 30% for Continuous Duty.

C = Continuous or Intermittent Torque - No need to De-Rate Torque Rating.

IMPORTANT: Refer to the back of this transmission section and read all notes associated with this application page. Some notes may affect the proper PTO selection.

CAUTION: INPUT SIGNAL REQUIRED - The Eaton UltraShift Plus transmission must have an input signal from the Power Take-Off when it is active. In this active state, the clutch engagement is controlled when the operator raises the engine speed to engage the clutch and drive the transmission main box countershaft, per EATON spec. "TRIG-2600". INCORRECT or NO PTO interface signal to the transmission will result in uncontrolled engagement of the clutch during PTO operation.

CAUTION: DO NOT use geared adapters with 442 A and C ratios.

(1) Input Gear Part No. 5-P-1004	(7) Input Gear Part No. 5-P-1104	(13) Input Gear Part No. 5-P-1322	(19) Input Gear Part No. 5-P-1494	(44) Input Gear Part No. 5-P-980
(2) Input Gear Part No. 5-P-1077	(8) Input Gear Part No. 5-P-1135	(14) Input Gear Part No. 5-P-1364	(38) Input Gear Part No. 5-P-283	(45) Filler block furnished with PTO
(3) Input Gear Part No. 5-P-1100	(9) Input Gear Part No. 5-P-1242	(15) Input Gear Part No. 5-P-1385	(39) Input Gear Part No. 5-P-285	
(4) Input Gear Part No. 5-P-1101	(10) Input Gear Part No. 5-P-1246	(16) Input Gear Part No. 5-P-1395	(40) Input Gear Part No. 5-P-325	
(5) Input Gear Part No. 5-P-1102	(11) Input Gear Part No. 5-P-1280	(17) Input Gear Part No. 5-P-1418	(42) Input Gear Part No. 5-P-721	
(6) Input Gear Part No. 5-P-1103	(12) Input Gear Part No. 5-P-1287	(18) Input Gear Part No. 5-P-1441	(43) Input Gear Part No. 5-P-971	

CHELSEA®

EATON FULLER

FLR-106

FO-10E308LL-VCS (UltraShift Plus) Thrushaft use BD mounting
 FO-11E308LL-VCS (UltraShift Plus) Thrushaft use BD mounting
 FO-12E308LL-VCS (UltraShift Plus) Thrushaft use BD mounting
 FO-14E308LL-VCS (UltraShift Plus) Thrushaft use BD mounting
 FO-16E308LL-VCS (UltraShift Plus) Thrushaft use BD mounting
 FO-17E308LL-VCS (UltraShift Plus) Thrushaft use BD Mounting

BOTTOM SIDE ONLY

RIGHT SIDE ONLY

TRANSMISSION GEAR DATA:

BOT 08-BOLT Opening Gear FORWARD of Centerline
 47 Teeth - SPUR

PITCH LINE TO APERTURE FACE:

0.8050" (20.4500MM)

TRANSMISSION GEAR DATA:

R.S. 06-BOLT Opening Gear FORWARD of Centerline
 45 Teeth - SPUR

PITCH LINE TO APERTURE FACE:

1.0850" (27.5600MM)

CAUTION: Application Approval Required for PTO Output Shaft Speeds Above 2500 RPM

PTO Model	Torq I / C †	Dir Rot	Engine %		Filler Block	Adapter Assy	Stud Kit	PTO Model	Torq I / C †	Dir Rot	Engine %		Filler Block	Adapter Assy	Stud Kit
			Fwd	Rev							Fwd	Rev			

ONE SPEED - TWO GEAR POWERSHIFT (AIR OR HYDRAULIC)

272XAAJX-*3 (29)	300 C	Opp	64			328481X	Furnished	272XAAJX-*3 (29)	300 C	Opp	61				Furnished
282XBAJX-*3 (20)	300 C	Opp	78		8-A-032		Furnished	272XBAJX-*3 (30)	300 C	Opp	75				Furnished
282XCAJX-*3 (21)	300 C	Opp	94		8-A-032		Furnished	272XCAJX-*3 (31)	300 C	Opp	90				Furnished
282XDAJX-*3 (22)	300 C	Opp	113		8-A-032		Furnished	272XDAJX-*3 (32)	300 C	Opp	108				Furnished
282XGAJX-*3 (23)	300 C	Opp	134		8-A-032		Furnished	272XGAJX-*3 (33)	300 C	Opp	128				Furnished
282XKAJX-*3 (24)	300 C	Opp	150		8-A-032		Furnished	272XKAJX-*3 (34)	300 C	Opp	150				Furnished
282XMAJX-*3 (25)	281 C	Opp	168		8-A-032		Furnished	272XMAJX-*3 (35)	294 C	Opp	161				Furnished
282XPAJX-*3 (26)	252 C	Opp	188		8-A-032		Furnished	272XPAJX-*3 (36)	263 C	Opp	180				Furnished
282XSAJX-*3 (27)	225 C	Opp	210		8-A-032		Furnished	272XSAJX-*3 (37)	235 C	Opp	201				Furnished
282XTAJX-*3 (28)	201 C	Opp	235		8-A-032		Furnished								

ONE SPEED - TWO GEAR - POWERSHIFT (AIR)

885XBAHX-*3 (3)	500 I	Opp	78				Furnished								
885XGAHX-*3 (8)	500 I	Opp	100				Furnished								
885XJAHX-*3 (5)	500 I	Opp	118				Furnished								
885XMAHX-*3 (6)	395 I	Opp	139				Furnished								

ONE SPEED - FORWARD & REVERSE

348XFAHX-*5 (41)	200 I	Opp	100	105			Furnished	340XFAHX-*5 (41)	200 I	Opp	96	101	7-A-140(45)		Furnished
352ZSAHX-*3 (1)	140 I	Opp	223	288		328564X	Furnished	352XSAHX-*3 (1)	140 I	Opp	213	276			Furnished
863XBAHX-*5	423 I	Opp	78	97			Furnished								

GEARED ADAPTERS

628XAHX-3AH	250 I	Eng			8-A-032		Furnished	626XAHX-3AH	250 I	Eng					Furnished
								630XAHX-3AH	250 I	Eng					Furnished
								645XAHX-3AH	250 I	Eng					Furnished

Continued on Next Page

† I = Intermittent Torque Only - De-rate Torque Rating 30% for Continuous Duty.

C = Continuous or Intermittent Torque - No need to De-Rate Torque Rating.

IMPORTANT: Refer to the back of this transmission section and read all notes associated with this application page.
 Some notes may affect the proper PTO selection.

CAUTION: INPUT SIGNAL REQUIRED - The Eaton UltraShift Plus transmission must have an input signal from the Power Take-Off when it is active. In this active state, the clutch engagement is controlled when the operator raises the engine speed to engage the clutch and drive the transmission main box countershaft, per EATON spec. "TRIG-2600". INCORRECT or NO PTO interface signal to the transmission will result in uncontrolled engagement of the clutch during PTO operation.

CAUTION: DO NOT use geared adapters with 442 A and C ratios.

(1) Input Gear Part No. 5-P-11004	(20) Input Gear Part No. 5-P-1510-11X	(25) Input Gear Part No. 5-P-1510-16X	(30) Input Gear Part No. 5-P-1510-2X	(35) Input Gear Part No. 5-P-1510-7X
(3) Input Gear Part No. 5-P-11100	(21) Input Gear Part No. 5-P-1510-12X	(26) Input Gear Part No. 5-P-1510-17X	(31) Input Gear Part No. 5-P-1510-3X	(36) Input Gear Part No. 5-P-1510-8X
(5) Input Gear Part No. 5-P-11102	(22) Input Gear Part No. 5-P-1510-13X	(27) Input Gear Part No. 5-P-1510-18X	(32) Input Gear Part No. 5-P-1510-4X	(37) Input Gear Part No. 5-P-1510-9X
(6) Input Gear Part No. 5-P-11103	(23) Input Gear Part No. 5-P-1510-14X	(28) Input Gear Part No. 5-P-1510-19X	(33) Input Gear Part No. 5-P-1510-5X	(41) Input Gear Part No. 5-P-581
(8) Input Gear Part No. 5-P-11135	(24) Input Gear Part No. 5-P-1510-15X	(29) Input Gear Part No. 5-P-1510-1X	(34) Input Gear Part No. 5-P-1510-6X	(45) Filler block furnished with PTO

FLR-106

EATON FULLER

CHELSEA®

FO-10E308LL-VCS (UltraShift Plus) Thrushaft use BD mounting
 FO-11E308LL-VCS (UltraShift Plus) Thrushaft use BD mounting
 FO-12E308LL-VCS (UltraShift Plus) Thrushaft use BD mounting
 FO-14E308LL-VCS (UltraShift Plus) Thrushaft use BD mounting
 FO-16E308LL-VCS (UltraShift Plus) Thrushaft use BD mounting
 FO-17E308LL-VCS (UltraShift Plus) Thrushaft use BD Mounting

REAR SIDE ONLY**TRANSMISSION GEAR DATA:**

REAR 00-BOLT Opening

PITCH LINE TO APERTURE FACE:**CAUTION: Application Approval Required for PTO Output Shaft Speeds Above 2500 RPM**

PTO Model	Torq	Dir Rot	Engine %		Filler Block	Adapter Assy	Stud Kit	PTO Model	Torq	Dir Rot	Engine %		Filler Block	Adapter Assy	Stud Kit
	I / C †		Fwd	Rev					I / C †		Fwd	Rev			

REAR MOUNT - MECHANICAL SHIFT (10 SPEED TRANSMISSIONS)

541-LBD-*.*	400 I	Eng	91				Furnished
541-MBD-*.*	350 I	Eng	117				Furnished
541-NBD-*.*	300 I	Eng	133				Furnished

† I = Intermittent Torque Only - De-rate Torque Rating 30% for Continuous Duty.

C = Continuous or Intermittent Torque - No need to De-Rate Torque Rating.

IMPORTANT: Refer to the back of this transmission section and read all notes associated with this application page. Some notes may affect the proper PTO selection.

CAUTION: INPUT SIGNAL REQUIRED - The Eaton UltraShift Plus transmission must have an input signal from the Power Take-Off when it is active. In this active state, the clutch engagement is controlled when the operator raises the engine speed to engage the clutch and drive the transmission main box countershaft, per EATON spec. "TRIG-2600". INCORRECT or NO PTO interface signal to the transmission will result in uncontrolled engagement of the clutch during PTO operation.

CAUTION: DO NOT use geared adapters with 442 A and C ratios.

CHELSEA®

EATON FULLER

FLR-107

F-14E16B-LSE (UltraShift Plus)
F-15E16B-LSE (UltraShift Plus)
F-17E16B-LSE (UltraShift Plus)
FM-15E16B-LSE (UltraShift Plus)
FO-10E309ALL-VMS (UltraShift Plus) Thrustshaft use BD mounting
FO-10E310C-VAS (UltraShift Plus) Thrustshaft use AT mounting
FO-11E309ALL-VMS (UltraShift Plus) Thrustshaft use BD mounting
FO-12E309ALL-VMS (UltraShift Plus) Thrustshaft use BD mounting

FO-12E310C-VAS (UltraShift Plus) Thrustshaft use AT mounting
FO-14E309ALL-VMS (UltraShift Plus) Thrustshaft use BD mounting
FO-14E310C-LAS (UltraShift Plus) Thrustshaft use AT mounting
FO-14E310C-VAS (UltraShift Plus) Thrustshaft use AT mounting
FO-14E313A-MHP (UltraShift Plus)
FO-14E313A-VHP (UltraShift Plus)
FO-14E318B-MXP (UltraShift Plus)
FO-14E318B-VXP (UltraShift Plus)

FO-16E309ALL-VMS (UltraShift Plus) Thrustshaft use BD mounting
FO-16E310C-LAS (UltraShift Plus) Thrustshaft use AT mounting
FO-16E310C-VAS (UltraShift Plus) Thrustshaft use AT mounting
FO-16E313A-MHP (UltraShift Plus)
FO-16E313A-VHP (UltraShift Plus)
FO-16E318B-MXP (UltraShift Plus)
FO-16E318B-VXP (UltraShift Plus)
FO-16E318B-VXP (UltraShift Plus)

BOTTOM SIDE ONLY

RIGHT SIDE ONLY

TRANSMISSION GEAR DATA:

BOT 08-BOLT Opening Gear FORWARD of Centerline
47 Teeth - SPUR

PITCH LINE TO APERTURE FACE:

0.8050" (20.4500MM)

TRANSMISSION GEAR DATA:

R.S. 06-BOLT Opening Gear FORWARD of Centerline
45 Teeth - SPUR

PITCH LINE TO APERTURE FACE:

1.0850" (27.5600MM)

CAUTION: Application Approval Required for PTO Output Shaft Speeds Above 2500 RPM

PTO Model	Torq I / C †	Dir Rot	Engine %		Filler Block	Adapter Assy	Stud Kit	PTO Model	Torq I / C †	Dir Rot	Engine %		Filler Block	Adapter Assy	Stud Kit
			Fwd	Rev							Fwd	Rev			

ONE SPEED - TWO GEAR - MECHANICAL SHIFT

489XAAHX-*5 (11)	250 I	Opp	61				Furnished	221XCAHX-*3	250 I	Eng	66	7-A-032(P)(44)	329138X	Furnished
489XCAHX-*5 (12)	250 I	Opp	78				Furnished	221XEAHX-*3	250 I	Eng	76		329138X	Furnished
489XFAHX-*5 (2)	250 I	Opp	96				Furnished	442XAAHX-*3 (11)	250 I	Opp	58			Furnished
489XHAHX-*5 (14)	250 I	Opp	111				Furnished	442XBAHX-*3 (17)	250 I	Eng	58		REQUIRED	Furnished
489XLAHX-*5 (1)	250 I	Opp	124				Furnished	442XCAHX-*3 (12)	250 I	Opp	74			Furnished
489XQAHX-*5 (1)	225 I	Opp	134				Furnished	442XFAHX-*3 (2)	250 I	Opp	92			Furnished
489XRAHX-*5 (1)	225 I	Opp	155				Furnished	442XHAXH-*3 (14)	250 I	Opp	107			Furnished
489XSAHX-*5 (1)	200 I	Opp	184				Furnished	442XLAHX-*3 (1)	250 I	Opp	119			Furnished
680XFAHX-*3 (9)	375 I	Opp	96				Furnished	442XQAHX-*3 (1)	225 I	Opp	128			Furnished
680XHAHX-*3 (19)	375 I	Opp	111				Furnished	442XRAHX-*3 (1)	225 I	Opp	148			Furnished
680XQAHX-*3 (10)	375 I	Opp	134				Furnished	660XFAHX-*3 (9)	375 I	Opp	92			Furnished
680XRAHX-*3 (18)	310 I	Opp	155				Furnished	660XHAHX-*3 (14)	375 I	Opp	107			Furnished
680XSAHX-*3 (13)	220 I	Opp	184				Furnished	660XQAHX-*3 (10)	375 I	Opp	128			Furnished
823XBAHX-*3 (38)	750 I	Opp	65				Furnished	660XRAHX-*3 (18)	340 I	Opp	148			Furnished
823XDAHX-*3 (42)	750 I	Opp	77				Furnished							
823XGAHX-*3 (43)	705 I	Opp	84				Furnished							
823XJAHX-*3 (39)	599 I	Opp	99				Furnished							
823XMAHX-*3 (37)	511 I	Opp	116				Furnished							
823XRAHX-*3 (41)	370 I	Opp	160				Furnished							
823XTKTX-*3 (16)	305 I	Opp	194		8-A-165(44)		Furnished							
880XBAHX-*3 (3)	500 I	Opp	65				Furnished							
880XDAHX-*3 (4)	500 I	Opp	77				Furnished							
880XGAHX-*3 (8)	500 I	Opp	84				Furnished							
880XJAHX-*3 (5)	500 I	Opp	99				Furnished							
880XMAHX-*3 (6)	500 I	Opp	116				Furnished							
880XQAHX-*3 (15)	435 I	Opp	136				Furnished							
880XRAHX-*3 (7)	370 I	Opp	160				Furnished							

ONE SPEED - TWO GEAR POWERSHIFT (AIR OR HYDRAULIC)

272XAAJX-*3 (29)	300 C	Opp	53			328481X	Furnished	272XAAJX-*3 (29)	300 C	Opp	51			Furnished
282XBAJX-*3 (20)	300 C	Opp	65		8-A-032		Furnished	272XBAJX-*3 (30)	300 C	Opp	63			Furnished
282XCAJX-*3 (21)	300 C	Opp	79		8-A-032		Furnished	272XCAJX-*3 (31)	300 C	Opp	76			Furnished
								272XDAXJX-*3 (32)	300 C	Opp	90			Furnished

† I = Intermittent Torque Only - De-rate Torque Rating 30% for Continuous Duty.

C = Continuous or Intermittent Torque - No need to De-Rate Torque Rating.

IMPORTANT: Refer to the back of this transmission section and read all notes associated with this application page. Some notes may affect the proper PTO selection.

CAUTION: INPUT SIGNAL REQUIRED - The Eaton UltraShift Plus transmission must have an input signal from the Power Take-Off when it is active. In this active state, the clutch engagement is controlled when the operator raises the engine speed to engage the clutch and drive the transmission main box countershaft, per EATON spec. "TRIG-2600". INCORRECT or NO PTO interface signal to the transmission will result in uncontrolled engagement of the clutch during PTO operation.

CAUTION: DO NOT use geared adapters with 442 A and C ratios.

- (1) Input Gear Part No. 5-P-1104
(2) Input Gear Part No. 5-P-1077
(3) Input Gear Part No. 5-P-1100
(4) Input Gear Part No. 5-P-1101
(5) Input Gear Part No. 5-P-1102
(6) Input Gear Part No. 5-P-1103
(7) Input Gear Part No. 5-P-1104

- (8) Input Gear Part No. 5-P-1135
(9) Input Gear Part No. 5-P-1242
(10) Input Gear Part No. 5-P-1246
(11) Input Gear Part No. 5-P-1280
(12) Input Gear Part No. 5-P-1287
(13) Input Gear Part No. 5-P-1322
(14) Input Gear Part No. 5-P-1364

- (15) Input Gear Part No. 5-P-1385
(16) Input Gear Part No. 5-P-1395
(17) Input Gear Part No. 5-P-1418
(18) Input Gear Part No. 5-P-1441
(19) Input Gear Part No. 5-P-1494
(20) Input Gear Part No. 5-P-1510-11X
(21) Input Gear Part No. 5-P-1510-12X

- (29) Input Gear Part No. 5-P-1510-1X
(30) Input Gear Part No. 5-P-1510-2X
(31) Input Gear Part No. 5-P-1510-3X
(32) Input Gear Part No. 5-P-1510-4X
(37) Input Gear Part No. 5-P-283
(38) Input Gear Part No. 5-P-285
(39) Input Gear Part No. 5-P-325

- (41) Input Gear Part No. 5-P-721
(42) Input Gear Part No. 5-P-971
(43) Input Gear Part No. 5-P-980
(44) Filler block furnished with PTO

FLR-107

EATON FULLER

CHELSEA®

F-14E16B-LSE (UltraShift Plus)
F-15E16B-LSE (UltraShift Plus)
F-17E16B-LSE (UltraShift Plus)
FM-15E16B-LSE (UltraShift Plus)
FO-10E309ALL-VMS (UltraShift Plus) ThruShaft use BD mounting
FO-10E310C-VAS (UltraShift Plus) ThruShaft use AT mounting
FO-11E309ALL-VMS (UltraShift Plus) ThruShaft use BD mounting
FO-12E309ALL-VMS (UltraShift Plus) ThruShaft use BD mounting

FO-12E310C-VAS (UltraShift Plus) ThruShaft use AT mounting
FO-14E309ALL-VMS (UltraShift Plus) ThruShaft use BD mounting
FO-14E310C-LAS (UltraShift Plus) ThruShaft use AT mounting
FO-14E310C-VAS (UltraShift Plus) ThruShaft use AT mounting
FO-14E313A-MHP (UltraShift Plus)
FO-14E313A-VHP (UltraShift Plus)
FO-14E318B-MXP (UltraShift Plus)
FO-14E318B-VXP (UltraShift Plus)

FO-16E309ALL-VMS (UltraShift Plus) ThruShaft use BD mounting
FO-16E310C-LAS (UltraShift Plus) ThruShaft use AT mounting
FO-16E310C-VAS (UltraShift Plus) ThruShaft use AT mounting
FO-16E313A-MHP (UltraShift Plus)
FO-16E313A-VHP (UltraShift Plus)
FO-16E318B-MXP (UltraShift Plus)
FO-16E318B-VXP (UltraShift Plus)
FO-16E318B-VXP (UltraShift Plus)

BOTTOM SIDE ONLY

RIGHT SIDE ONLY

TRANSMISSION GEAR DATA:

BOT 08-BOLT Opening Gear FORWARD of Centerline
47 Teeth - SPUR

PITCH LINE TO APERTURE FACE:

0.8050" (20.4500MM)

TRANSMISSION GEAR DATA:

R.S. 06-BOLT Opening Gear FORWARD of Centerline
45 Teeth - SPUR

PITCH LINE TO APERTURE FACE:

1.0850" (27.5600MM)

CAUTION: Application Approval Required for PTO Output Shaft Speeds Above 2500 RPM

PTO Model	Torq I / C †	Dir Rot	Engine %		Filler Block	Adapter Assy	Stud Kit	PTO Model	Torq I / C †	Dir Rot	Engine %		Filler Block	Adapter Assy	Stud Kit
			Fwd	Rev							Fwd	Rev			

ONE SPEED - TWO GEAR POWERSHIFT (AIR OR HYDRAULIC)

282XDAJX-*3 (22)	300 C	Opp	95		8-A-032		Furnished	272XGAJX-*3 (32)	300 C	Opp	108					Furnished
282XGAJX-*3 (23)	300 C	Opp	112		8-A-032		Furnished	272XKAJX-*3 (33)	300 C	Opp	120					Furnished
282XKAJX-*3 (24)	300 C	Opp	126		8-A-032		Furnished	272XMAJX-*3 (34)	294 C	Opp	135					Furnished
282XMAJX-*3 (25)	281 C	Opp	140		8-A-032		Furnished	272XPAJX-*3 (35)	263 C	Opp	150					Furnished
282XPAJX-*3 (26)	252 C	Opp	157		8-A-032		Furnished	272XSAJX-*3 (36)	235 C	Opp	168					Furnished
282XSAJX-*3 (27)	225 C	Opp	176		8-A-032		Furnished									
282XTAJX-*3 (28)	201 C	Opp	188		8-A-032		Furnished									

ONE SPEED - TWO GEAR - POWERSHIFT (AIR)

885XBAHX-*3 (3)	500 I	Opp	65				Furnished									
885XGAHX-*3 (8)	500 I	Opp	84				Furnished									
885XJAHX-*3 (5)	500 I	Opp	99				Furnished									
885XMAHX-*3 (6)	500 I	Opp	116				Furnished									

ONE SPEED - FORWARD & REVERSE

348XFAHX-*5 (40)	200 I	Opp	84	88			Furnished	340XFAHX-*5 (40)	200 I	Opp	80	84	7-A-140(44)			Furnished
352ZSAHX-*3 (1)	140 I	Opp	187	241		328564X	Furnished	352XSAHX-*3 (1)	140 I	Opp	179	231				Furnished
863XBAHX-*5	423 I	Opp	65	81			Furnished									

GEARED ADAPTERS

626XAHX-3AH	250 I	Eng			8-A-032		Furnished	626XAHX-3AH	250 I	Eng						Furnished
								630XAHX-3AH	250 I	Eng						Furnished
								645XAHX-3AH	250 I	Eng						Furnished

Continued on Next Page

† I = Intermittent Torque Only - De-rate Torque Rating 30% for Continuous Duty.

C = Continuous or Intermittent Torque - No need to De-Rate Torque Rating.

IMPORTANT: Refer to the back of this transmission section and read all notes associated with this application page. Some notes may affect the proper PTO selection.

CAUTION: INPUT SIGNAL REQUIRED - The Eaton UltraShift Plus transmission must have an input signal from the Power Take-Off when it is active. In this active state, the clutch engagement is controlled when the operator raises the engine speed to engage the clutch and drive the transmission main box countershaft, per EATON spec. "TRIG-2600". INCORRECT or NO PTO interface signal to the transmission will result in uncontrolled engagement of the clutch during PTO operation.

CAUTION: DO NOT use geared adapters with 442 A and C ratios.

(1) Input Gear Part No. 5-P-1004	(22) Input Gear Part No. 5-P-1510-13X	(27) Input Gear Part No. 5-P-1510-18X	(35) Input Gear Part No. 5-P-1510-8X
(3) Input Gear Part No. 5-P-1100	(23) Input Gear Part No. 5-P-1510-14X	(28) Input Gear Part No. 5-P-1510-19X	(36) Input Gear Part No. 5-P-1510-9X
(5) Input Gear Part No. 5-P-1102	(24) Input Gear Part No. 5-P-1510-15X	(32) Input Gear Part No. 5-P-1510-5X	(40) Input Gear Part No. 5-P-581
(6) Input Gear Part No. 5-P-1103	(25) Input Gear Part No. 5-P-1510-16X	(33) Input Gear Part No. 5-P-1510-6X	(44) Filler block furnished with PTO
(8) Input Gear Part No. 5-P-1135	(26) Input Gear Part No. 5-P-1510-17X	(34) Input Gear Part No. 5-P-1510-7X	

CHELSEA®

EATON FULLER

FLR-107

F-14E16B-LSE (UltraShift Plus)	FO-12E310C-VAS (UltraShift Plus) Thrushaft use AT mounting	FO-16E309ALL-VMS (UltraShift Plus) Thrushaft use BD mounting
F-15E16B-LSE (UltraShift Plus)	FO-14E309ALL-VMS (UltraShift Plus) Thrushaft use BD mounting	FO-16E310C-LAS (UltraShift Plus) Thrushaft use AT mounting
F-17E16B-LSE (UltraShift Plus)	FO-14E310C-LAS (UltraShift Plus) Thrushaft use AT mounting	FO-16E310C-VAS (UltraShift Plus) Thrushaft use AT mounting
FM-15E16B-LSE (UltraShift Plus)	FO-14E310C-VAS (UltraShift Plus) Thrushaft use AT mounting	FO-16E313A-MHP (UltraShift Plus)
FO-10E309ALL-VMS (UltraShift Plus) Thrushaft use BD mounting	FO-14E313A-MHP (UltraShift Plus)	FO-16E313A-VHP (UltraShift Plus)
FO-10E310C-VAS (UltraShift Plus) Thrushaft use AT mounting	FO-14E313A-VHP (UltraShift Plus)	FO-16E318B-MXP (UltraShift Plus)
FO-11E309ALL-VMS (UltraShift Plus) Thrushaft use BD mounting	FO-14E318B-MXP (UltraShift Plus)	FO-16E318B-VXP (UltraShift Plus)
FO-12E309ALL-VMS (UltraShift Plus) Thrushaft use BD mounting	FO-14E318B-VXP (UltraShift Plus)	

REAR SIDE ONLY**TRANSMISSION GEAR DATA:**

REAR 00-BOLT Opening

PITCH LINE TO APERTURE FACE:**CAUTION: Application Approval Required for PTO Output Shaft Speeds Above 2500 RPM**

PTO Model	Torq	Dir Rot	Engine %		Filler Block	Adapter Assy	Stud Kit	PTO Model	Torq	Dir Rot	Engine %		Filler Block	Adapter Assy	Stud Kit
	I / C †		Fwd	Rev					I / C †		Fwd	Rev			

REAR MOUNT - MECHANICAL SHIFT (9 SPEED TRANSMISSIONS)

541-LBD-*.*	400 I	Eng	76				Furnished
541-MBD-*.*	350 I	Eng	98				Furnished
541-NBD-*.*	300 I	Eng	112				Furnished

† I = Intermittent Torque Only - De-rate Torque Rating 30% for Continuous Duty.

C = Continuous or Intermittent Torque - No need to De-Rate Torque Rating.

IMPORTANT: Refer to the back of this transmission section and read all notes associated with this application page. Some notes may affect the proper PTO selection.

CAUTION: INPUT SIGNAL REQUIRED - The Eaton UltraShift Plus transmission must have an input signal from the Power Take-Off when it is active. In this active state, the clutch engagement is controlled when the operator raises the engine speed to engage the clutch and drive the transmission main box countershaft, per EATON spec. "TRIG-2600". INCORRECT or NO PTO interface signal to the transmission will result in uncontrolled engagement of the clutch during PTO operation.

CAUTION: DO NOT use geared adapters with 442 A and C ratios.

Eaton Fuller

FLR-111

EATON FULLER



FM-14E310B-LAS (UltraShift Plus) Thrustshaft use AT mounting
FM-15E310B-LAS (UltraShift Plus) Thrustshaft use AT mounting

BOTTOM SIDE ONLY

RIGHT SIDE ONLY

TRANSMISSION GEAR DATA:

BOT 08-BOLT Opening Gear FORWARD of Centerline
47 Teeth - SPUR

PITCH LINE TO APERTURE FACE:

0.8050" (20.4500MM)

TRANSMISSION GEAR DATA:

R.S. 06-BOLT Opening Gear FORWARD of Centerline
45 Teeth - SPUR

PITCH LINE TO APERTURE FACE:

1.0850" (27.5600MM)

CAUTION: Application Approval Required for PTO Output Shaft Speeds Above 2500 RPM

PTO Model	Torq I / C †	Dir Rot	Engine %		Filler Block	Adapter Assy	Stud Kit	PTO Model	Torq I / C †	Dir Rot	Engine %		Filler Block	Adapter Assy	Stud Kit
			Fwd	Rev							Fwd	Rev			

ONE SPEED - TWO GEAR - MECHANICAL SHIFT

221ZCAHX-*3	250 I	Opp	61		7-A-032(P)(42)	328564X	Furnished	221XCAHX-*3	250 I	Opp	58		7-A-032(42)		Furnished
221ZEAHX-*3	250 I	Opp	70			328564X	Furnished	221XEAHX-*3	250 I	Opp	67				Furnished
489XAAHX-*5 (12)	250 I	Opp	54				Furnished	442XAAHX-*3 (12)	250 I	Opp	51				Furnished
489XCAHX-*5 (13)	250 I	Opp	69				Furnished	442XBAHX-*3 (18)	250 I	Eng	51			REQUIRED	Furnished
489XFAHX-*5 (2)	250 I	Opp	85				Furnished	442XCAHX-*3 (13)	250 I	Opp	66				Furnished
489XHAHX-*5 (15)	250 I	Opp	99				Furnished	442XFAHX-*3 (2)	250 I	Opp	81				Furnished
489XLAHX-*5 (1)	250 I	Opp	110				Furnished	442XHAHX-*3 (15)	250 I	Opp	94				Furnished
489XQAHX-*5 (1)	225 I	Opp	118				Furnished	442XLAHX-*3 (1)	250 I	Opp	105				Furnished
489XRAHX-*5 (1)	225 I	Opp	137				Furnished	442XQAHX-*3 (1)	225 I	Opp	113				Furnished
489XSAHX-*5 (1)	200 I	Opp	163				Furnished	442XRAHX-*3 (1)	225 I	Opp	131				Furnished
489XUAHX-*5 (1)	195 I	Opp	194				Furnished	442XSAHX-*3 (1)	200 I	Opp	156				Furnished
489XWAHX-*5 (1)	175 I	Opp	229				Furnished	442XUAHX-*3 (1)	195 I	Opp	186				Furnished
489XXAHX-*5 (1)	140 I	Opp	271				Furnished	442XWAHX-*3 (1)	175 I	Opp	219				Furnished
680XFAHX-*3 (10)	375 I	Opp	85				Furnished	442XXAHX-*3 (1)	140 I	Opp	259				Furnished
680XHAHX-*3 (20)	375 I	Opp	99				Furnished	660XFAHX-*3 (10)	375 I	Opp	81				Furnished
680XQAHX-*3 (11)	375 I	Opp	118				Furnished	660XHAHX-*3 (15)	375 I	Opp	94				Furnished
680XRAHX-*3 (19)	350 I	Opp	137				Furnished	660XQAHX-*3 (11)	375 I	Opp	113				Furnished
680XSAHX-*3 (14)	322 I	Opp	163				Furnished	660XRAHX-*3 (19)	350 I	Opp	131				Furnished
823XBAHX-*3 (40)	750 I	Opp	58				Furnished	660XSAHX-*3 (14)	336 I	Opp	156				Furnished
823XDAHX-*3 (36)	750 I	Opp	69				Furnished								
823XGAHX-*3 (41)	705 I	Opp	74				Furnished								
823XJAHX-*3 (37)	599 I	Opp	88				Furnished								
823XMAHX-*3 (35)	511 I	Opp	103				Furnished								
823XRAHX-*3 (39)	370 I	Opp	142				Furnished								
823XTKTX-*3 (17)	305 I	Opp	172		8-A-165(42)		Furnished								
880XBAHX-*3 (3)	500 I	Opp	58				Furnished								
880XDAHX-*3 (4)	500 I	Opp	69				Furnished								
880XGAHX-*3 (9)	500 I	Opp	74				Furnished								
880XJAHX-*3 (5)	500 I	Opp	88				Furnished								
880XMAHX-*3 (6)	500 I	Opp	103				Furnished								
880XQAHX-*3 (16)	435 I	Opp	120				Furnished								

Continued on Next Page

† I = Intermittent Torque Only - De-rate Torque Rating 30% for Continuous Duty.

C = Continuous or Intermittent Torque - No need to De-Rate Torque Rating.

IMPORTANT: Refer to the back of this transmission section and read all notes associated with this application page. Some notes may affect the proper PTO selection.

CAUTION: INPUT SIGNAL REQUIRED - The Eaton UltraShift transmission must have an input signal from the Power Take-Off when it is active. In this active state, the clutch engagement is controlled when the operator raises the engine speed to engage the clutch and drive the transmission main box countershaft. Minimum engine/transmission speed required for PTO operation is 1000 RPM, per EATON spec. "TRIG-2600". INCORRECT or NO PTO interface signal to the transmission will result in uncontrolled engagement of the clutch during PTO operation.

CAUTION: DO NOT use geared adapters with 442 A and C ratios.

- | | | | | |
|----------------------------------|-----------------------------------|-----------------------------------|-----------------------------------|--------------------------------------|
| (1) Input Gear Part No. 5-P-1004 | (6) Input Gear Part No. 5-P-1103 | (13) Input Gear Part No. 5-P-1287 | (18) Input Gear Part No. 5-P-1418 | (37) Input Gear Part No. 5-P-325 |
| (2) Input Gear Part No. 5-P-1077 | (9) Input Gear Part No. 5-P-1135 | (14) Input Gear Part No. 5-P-1322 | (19) Input Gear Part No. 5-P-1441 | (39) Input Gear Part No. 5-P-721 |
| (3) Input Gear Part No. 5-P-1100 | (10) Input Gear Part No. 5-P-1242 | (15) Input Gear Part No. 5-P-1364 | (20) Input Gear Part No. 5-P-1494 | (40) Input Gear Part No. 5-P-971 |
| (4) Input Gear Part No. 5-P-1101 | (11) Input Gear Part No. 5-P-1246 | (16) Input Gear Part No. 5-P-1385 | (35) Input Gear Part No. 5-P-283 | (41) Input Gear Part No. 5-P-980 |
| (5) Input Gear Part No. 5-P-1102 | (12) Input Gear Part No. 5-P-1280 | (17) Input Gear Part No. 5-P-1395 | (36) Input Gear Part No. 5-P-285 | (42) Filler block furnished with PTO |



October 2022
5.5.76

Parker Hannifin Corporation
Chelsea Products Division
Olive Branch, MS 38654 USA

CHELSEA®

EATON FULLER

FLR-111

FM-14E310B-LAS (UltraShift Plus) Thrustshaft use AT mounting
FM-15E310B-LAS (UltraShift Plus) Thrustshaft use AT mounting

BOTTOM SIDE ONLY

RIGHT SIDE ONLY

TRANSMISSION GEAR DATA:

BOT 08-BOLT Opening Gear FORWARD of Centerline
47 Teeth - SPUR

PITCH LINE TO APERTURE FACE:

0.8050" (20.4500MM)

TRANSMISSION GEAR DATA:

R.S. 06-BOLT Opening Gear FORWARD of Centerline
45 Teeth - SPUR

PITCH LINE TO APERTURE FACE:

1.0850" (27.5600MM)

CAUTION: Application Approval Required for PTO Output Shaft Speeds Above 2500 RPM

PTO Model	Torq I / C †	Dir Rot	Engine %		Filler Block	Adapter Assy	Stud Kit	PTO Model	Torq I / C †	Dir Rot	Engine %		Filler Block	Adapter Assy	Stud Kit
			Fwd	Rev							Fwd	Rev			

ONE SPEED - TWO GEAR - MECHANICAL SHIFT

880XRAHX-*3 (7)	370 I	Opp	142				Furnished								
880XTAHX-*3 (8)	287 I	Opp	183				Furnished								

ONE SPEED - TWO GEAR POWERSHIFT (AIR OR HYDRAULIC)

272XAAJX-*3 (30)	300 C	Opp	47			328481X	Furnished	272XAAJX-*3 (30)	300 C	Opp	45				Furnished
282XBAJX-*3 (21)	300 C	Opp	58		8-A-032		Furnished	272XBAJX-*3 (31)	300 C	Opp	55				Furnished
282XCAJX-*3 (22)	300 C	Opp	70		8-A-032		Furnished	272XCAJX-*3 (32)	300 C	Opp	67				Furnished
282XDAJX-*3 (23)	300 C	Opp	84		8-A-032		Furnished	272XDAJX-*3 (33)	300 C	Opp	80				Furnished
282XGAJX-*3 (24)	300 C	Opp	100		8-A-032		Furnished	272XGAJX-*3 (34)	300 C	Opp	95				Furnished
282XKAJX-*3 (25)	300 C	Opp	111		8-A-032		Furnished	272XKAJX-*3 (35)	300 C	Opp	107				Furnished
282XMAJX-*3 (26)	300 C	Opp	124		8-A-032		Furnished	272XMAJX-*3 (36)	300 C	Opp	119				Furnished
282XPAJX-*3 (27)	300 C	Opp	139		8-A-032		Furnished	272XPAJX-*3 (37)	300 C	Opp	133				Furnished
282XSAJX-*3 (28)	300 C	Opp	156		8-A-032		Furnished	272XSAJX-*3 (38)	300 C	Opp	149				Furnished
282XTAJX-*3 (29)	300 C	Opp	174		8-A-032		Furnished								

ONE SPEED - POWERSHIFT LOW PROFILE (AIR OR HYDRAULIC)

272MDAJX-*3 (32)	300 C	Opp	80												Furnished
------------------	-------	-----	----	--	--	--	--	--	--	--	--	--	--	--	-----------

ONE SPEED - TWO GEAR - POWERSHIFT (AIR)

885XBAHX-*3 (3)	500 I	Opp	58				Furnished								
885XGAHX-*3 (9)	500 I	Opp	74				Furnished								
885XJAHX-*3 (5)	500 I	Opp	88				Furnished								
885XMAHX-*3 (6)	500 I	Opp	103				Furnished								

ONE SPEED - FORWARD & REVERSE

348XFAHX-*5 (39)	200 I	Opp	74	78			Furnished	340XFAHX-*5 (39)	200 I	Opp	71	75	7-A-140(42)		Furnished
863XBAHX-*5	423 I	Opp	58	72			Furnished								

GEARED ADAPTERS

628XAHX-4AH	250 I	Eng			8-A-032		Furnished	626XAHX-3AH	250 I	Eng					Furnished
								630-02	250 I	Eng					Furnished

Continued on Next Page

† I = Intermittent Torque Only - De-rate Torque Rating 30% for Continuous Duty.

C = Continuous or Intermittent Torque - No need to De-Rate Torque Rating.

IMPORTANT: Refer to the back of this transmission section and read all notes associated with this application page. Some notes may affect the proper PTO selection.

CAUTION: INPUT SIGNAL REQUIRED - The Eaton UltraShift transmission must have an input signal from the Power Take-Off when it is active. In this active state, the clutch engagement is controlled when the operator raises the engine speed to engage the clutch and drive the transmission main box countershaft. Minimum engine/transmission speed required for PTO operation is 1000 RPM, per EATON spec. "TRIG-2600". INCORRECT or NO PTO interface signal to the transmission will result in uncontrolled engagement of the clutch during PTO operation.

CAUTION: DO NOT use geared adapters with 442 A and C ratios.

(3) Input Gear Part No. 5-P-1100	(21) Input Gear Part No. 5-P-1510-11X	(27) Input Gear Part No. 5-P-1510-17X	(33) Input Gear Part No. 5-P-1510-4X	(39) Input Gear Part No. 5-P-581
(5) Input Gear Part No. 5-P-1102	(22) Input Gear Part No. 5-P-1510-12X	(28) Input Gear Part No. 5-P-1510-18X	(34) Input Gear Part No. 5-P-1510-5X	(42) Filler block furnished with PTO
(6) Input Gear Part No. 5-P-1103	(23) Input Gear Part No. 5-P-1510-13X	(29) Input Gear Part No. 5-P-1510-19X	(35) Input Gear Part No. 5-P-1510-6X	
(7) Input Gear Part No. 5-P-1104	(24) Input Gear Part No. 5-P-1510-14X	(30) Input Gear Part No. 5-P-1510-1X	(36) Input Gear Part No. 5-P-1510-7X	
(8) Input Gear Part No. 5-P-1105	(25) Input Gear Part No. 5-P-1510-15X	(31) Input Gear Part No. 5-P-1510-2X	(37) Input Gear Part No. 5-P-1510-8X	
(9) Input Gear Part No. 5-P-1135	(26) Input Gear Part No. 5-P-1510-16X	(32) Input Gear Part No. 5-P-1510-3X	(38) Input Gear Part No. 5-P-1510-9X	

FLR-111

EATON FULLER

CHELSEA®

FM-14E310B-LAS (UltraShift Plus) Thrushaft use AT mounting
FM-15E310B-LAS (UltraShift Plus) Thrushaft use AT mounting

BOTTOM SIDE ONLY

RIGHT SIDE ONLY

TRANSMISSION GEAR DATA:

BOT 08-BOLT Opening Gear FORWARD of Centerline
47 Teeth - SPUR

PITCH LINE TO APERTURE FACE:

0.8050" (20.4500MM)

TRANSMISSION GEAR DATA:

R.S. 06-BOLT Opening Gear FORWARD of Centerline
45 Teeth - SPUR

PITCH LINE TO APERTURE FACE:

1.0850" (27.5600MM)

CAUTION: Application Approval Required for PTO Output Shaft Speeds Above 2500 RPM

PTO Model	Torq	Dir Rot	Engine %		Filler Block	Adapter Assy	Stud Kit	PTO Model	Torq	Dir Rot	Engine %		Filler Block	Adapter Assy	Stud Kit
	I / C †		Fwd	Rev					I / C †		Fwd	Rev			

GEARED ADAPTERS

630XAHX-3AH	250 I	Eng	Furnished
645XAHX-3AH	250 I	Eng	Furnished

Continued on Next Page

† I = Intermittent Torque Only - De-rate Torque Rating 30% for Continuous Duty.

C = Continuous or Intermittent Torque - No need to De-Rate Torque Rating.

IMPORTANT: Refer to the back of this transmission section and read all notes associated with this application page. Some notes may affect the proper PTO selection.

CAUTION: INPUT SIGNAL REQUIRED - The Eaton UltraShift transmission must have an input signal from the Power Take-Off when it is active. In this active state, the clutch engagement is controlled when the operator raises the engine speed to engage the clutch and drive the transmission main box countershaft. Minimum engine/transmission speed required for PTO operation is 1000 RPM, per EATON spec. "TRIG-2600". INCORRECT or NO PTO interface signal to the transmission will result in uncontrolled engagement of the clutch during PTO operation.

CAUTION: DO NOT use geared adapters with 442 A and C ratios.

Eaton Fuller

FAO-11810C (Advantage Series) ThruShaft use AV mounting FAO-12810C (Advantage Series) ThruShaft use AV mounting FAO-13810C (Advantage Series) ThruShaft use AV mounting FAO-14810C (Advantage Series) ThruShaft use AV mounting FAO-14810C-EA3 (Advantage Series Automated) ThruShaft use AV mounting FAO-15810C (Advantage Series) ThruShaft use AV mounting FAO-16810C (Advantage Series) ThruShaft use AV mounting FAO-16810C-EA3 (Advantage Series Automated) ThruShaft use AV mounting	FAO-16810S-EN3 (Advantage Series Automated) ThruShaft use AV mounting FAO-16810S-EP3 (Advantage Series Automated) ThruShaft use AV mounting FAOF-11810C (Advantage Series) ThruShaft use AV mounting FAOF-12810C (Advantage Series) ThruShaft use AV mounting FAOF-13810C (Advantage Series) ThruShaft use AV mounting FAOF-14810C (Advantage Series) ThruShaft use AV mounting FAOF-15810C (Advantage Series) ThruShaft use AV mounting FAOF-16810C (Advantage Series) ThruShaft use AV mounting	FAOM-14810C (Advantage Series) ThruShaft use AV mounting FAOM-14810S-EC3 (Advantage Series Automated) ThruShaft use AV mounting FAOM-15810C (Advantage Series) ThruShaft use AV mounting FAOM-15810C-EA3 (Advantage Series Automated) ThruShaft use AV mounting FAOM-15810S-EC3 (Advantage Series Automated) ThruShaft use AV mounting FAOM-15810S-EN3 (Advantage Series Automated) ThruShaft use AV mounting FAOM-15810S-EP3 (Advantage Series Automated) ThruShaft use AV mounting FAOM-16810C (Advantage Series) ThruShaft use AV mounting
--	--	--

BOTTOM SIDE ONLY	RIGHT SIDE ONLY
TRANSMISSION GEAR DATA: BOT 08-BOLT Opening Gear FORWARD of Centerline 47 Teeth - SPUR PITCH LINE TO APERTURE FACE: 0.8050" (20.4500MM)	TRANSMISSION GEAR DATA: R.S. 06-BOLT Opening Gear FORWARD of Centerline 45 Teeth - SPUR PITCH LINE TO APERTURE FACE: 1.0850" (27.5600MM)

CAUTION: Application Approval Required for PTO Output Shaft Speeds Above 2500 RPM

PTO Model	Torq I / C †	Dir Rot	Engine %		Filler Block	Adapter Assy	Stud Kit	PTO Model	Torq I / C †	Dir Rot	Engine %		Filler Block	Adapter Assy	Stud Kit
			Fwd	Rev							Fwd	Rev			

ONE SPEED - TWO GEAR - MECHANICAL SHIFT

489XAAHX-*5 (11)	250 I	Opp	61				Furnished	221XCAHX-*3	250 I	Eng	66	7-A-032(P)(45)	329138X	Furnished
489XCAHX-*5 (12)	250 I	Opp	78				Furnished	221XEAHX-*3	250 I	Eng	76		329138X	Furnished
489XFAHX-*5 (2)	250 I	Opp	96				Furnished	442XAAHX-*3 (11)	250 I	Opp	58			Furnished
489XHAHX-*5 (14)	250 I	Opp	111				Furnished	442XBAHX-*3 (17)	250 I	Eng	58		REQUIRED	Furnished
489XLAHX-*5 (1)	250 I	Opp	124				Furnished	442XCAHX-*3 (12)	250 I	Opp	74			Furnished
489XQAHX-*5 (1)	225 I	Opp	134				Furnished	442XFAHX-*3 (2)	250 I	Opp	92			Furnished
489XRAHX-*5 (1)	225 I	Opp	155				Furnished	442XHAAHX-*3 (14)	250 I	Opp	107			Furnished
489XSAHX-*5 (1)	200 I	Opp	184				Furnished	442XLAHX-*3 (1)	250 I	Opp	119			Furnished
680XFAHX-*3 (9)	375 I	Opp	96				Furnished	442XQAHX-*3 (1)	225 I	Opp	128			Furnished
680XHAHX-*3 (19)	375 I	Opp	111				Furnished	442XRAHX-*3 (1)	225 I	Opp	148			Furnished
680XQAHX-*3 (10)	375 I	Opp	134				Furnished	660XFAHX-*3 (9)	375 I	Opp	92			Furnished
680XRAHX-*3 (18)	350 I	Opp	155				Furnished	660XHAHX-*3 (14)	375 I	Opp	107			Furnished
680XSAHX-*3 (13)	322 I	Opp	184				Furnished	660XQAHX-*3 (10)	375 I	Opp	128			Furnished
823XBAHX-*3 (39)	750 I	Opp	65				Furnished	660XRAHX-*3 (18)	350 I	Opp	148			Furnished
823XDAHX-*3 (43)	750 I	Opp	77				Furnished							
823XGAHX-*3 (44)	705 I	Opp	84				Furnished							
823XJAHX-*3 (40)	599 I	Opp	99				Furnished							
823XMAHX-*3 (38)	511 I	Opp	116				Furnished							
823XRAHX-*3 (42)	370 I	Opp	160				Furnished							
823XTKTX-*3 (16)	305 I	Opp	194		8-A-165(T)(45)		Furnished							
880XBAHX-*3 (3)	500 I	Opp	65				Furnished							
880XDAHX-*3 (4)	500 I	Opp	77				Furnished							
880XGAHX-*3 (8)	500 I	Opp	84				Furnished							
880XJAHX-*3 (5)	500 I	Opp	99				Furnished							
880XMAHX-*3 (6)	500 I	Opp	116				Furnished							
880XQAHX-*3 (15)	435 I	Opp	136				Furnished							
880XRAHX-*3 (7)	370 I	Opp	160				Furnished							

ONE SPEED - TWO GEAR POWERSHIFT (AIR OR HYDRAULIC)

272XAAJX-*3 (29)	300 C	Opp	53			328481X	Furnished	272XAAJX-*3 (29)	300 C	Opp	51			Furnished
282XBAJX-*3 (20)	300 C	Opp	65		8-A-032		Furnished	272XBAJX-*3 (30)	300 C	Opp	63			Furnished
282XCAJX-*3 (21)	300 C	Opp	79		8-A-032		Furnished	272XCAJX-*3 (31)	300 C	Opp	76			Furnished

Continued on Next Page

† I = Intermittent Torque Only - De-rate Torque Rating 30% for Continuous Duty. C = Continuous or Intermittent Torque - No need to De-Rate Torque Rating.

IMPORTANT: Refer to the back of this transmission section and read all notes associated with this application page. Some notes may affect the proper PTO selection.

CAUTION: INPUT SIGNAL REQUIRED - In any case a PTO is used, regardless of PTO style, the transmission must have an input signal from the PTO when it is active. EATON requires the OEM to provide a "PTO Active" input connection to the transmission ECU. Refer to the Vehicle OEM for wire connection information and to Eaton TRIG2600 for Transmission/PTO Operations.

CAUTION: There is adjacent gear interference in the transmission that prevents the 489*U,W,X ratios from being used. 880*T is also affected.

CAUTION: DO NOT use geared adapters with 442 A and C ratios.

- | | | | | |
|----------------------------------|-----------------------------------|---------------------------------------|--------------------------------------|--------------------------------------|
| (1) Input Gear Part No. 5-P-1104 | (8) Input Gear Part No. 5-P-1135 | (15) Input Gear Part No. 5-P-1385 | (29) Input Gear Part No. 5-P-1510-1X | (43) Input Gear Part No. 5-P-971 |
| (2) Input Gear Part No. 5-P-1077 | (9) Input Gear Part No. 5-P-1242 | (16) Input Gear Part No. 5-P-1395 | (30) Input Gear Part No. 5-P-1510-2X | (44) Input Gear Part No. 5-P-980 |
| (3) Input Gear Part No. 5-P-1100 | (10) Input Gear Part No. 5-P-1246 | (17) Input Gear Part No. 5-P-1418 | (31) Input Gear Part No. 5-P-1510-3X | (45) Filler block furnished with PTO |
| (4) Input Gear Part No. 5-P-1101 | (11) Input Gear Part No. 5-P-1280 | (18) Input Gear Part No. 5-P-1441 | (38) Input Gear Part No. 5-P-283 | |
| (5) Input Gear Part No. 5-P-1102 | (12) Input Gear Part No. 5-P-1287 | (19) Input Gear Part No. 5-P-1494 | (39) Input Gear Part No. 5-P-285 | |
| (6) Input Gear Part No. 5-P-1103 | (13) Input Gear Part No. 5-P-1322 | (20) Input Gear Part No. 5-P-1510-11X | (40) Input Gear Part No. 5-P-325 | |
| (7) Input Gear Part No. 5-P-1104 | (14) Input Gear Part No. 5-P-1364 | (21) Input Gear Part No. 5-P-1510-12X | (42) Input Gear Part No. 5-P-721 | |

FLR-112

EATON FULLER

CHELSEA®

FAO-11810C (Advantage Series) ThruShaft use AV mounting
FAO-12810C (Advantage Series) ThruShaft use AV mounting
FAO-13810C (Advantage Series) ThruShaft use AV mounting
FAO-14810C (Advantage Series) ThruShaft use AV mounting
FAO-14810C-EA3 (Advantage Series Automated) ThruShaft use AV mounting
FAO-15810C (Advantage Series) ThruShaft use AV mounting
FAO-16810C (Advantage Series) ThruShaft use AV mounting
FAO-16810C-EA3 (Advantage Series Automated) ThruShaft use AV mounting

FAO-16810S-EN3 (Advantage Series Automated) ThruShaft use AV mounting
FAO-16810S-EP3 (Advantage Series Automated) ThruShaft use AV mounting
FAOF-11810C (Advantage Series) ThruShaft use AV mounting
FAOF-12810C (Advantage Series) ThruShaft use AV mounting
FAOF-13810C (Advantage Series) ThruShaft use AV mounting
FAOF-14810C (Advantage Series) ThruShaft use AV mounting
FAOF-15810C (Advantage Series) ThruShaft use AV mounting
FAOF-16810C (Advantage Series) ThruShaft use AV mounting

FAOM-14810C (Advantage Series) ThruShaft use AV mounting
FAOM-14810S-EC3 (Advantage Series Automated) ThruShaft use AV mounting
FAOM-15810C (Advantage Series) ThruShaft use AV mounting
FAOM-15810C-EA3 (Advantage Series Automated) ThruShaft use AV mounting
FAOM-15810S-EC3 (Advantage Series Automated) ThruShaft use AV mounting
FAOM-15810S-EN3 (Advantage Series Automated) ThruShaft use AV mounting
FAOM-15810S-EP3 (Advantage Series Automated) ThruShaft use AV mounting
FAOM-16810C (Advantage Series) ThruShaft use AV mounting

BOTTOM SIDE ONLY

RIGHT SIDE ONLY

TRANSMISSION GEAR DATA:

BOT 08-BOLT Opening Gear FORWARD of Centerline
47 Teeth - SPUR

PITCH LINE TO APERTURE FACE:

0.8050" (20.4500MM)

TRANSMISSION GEAR DATA:

R.S. 06-BOLT Opening Gear FORWARD of Centerline
45 Teeth - SPUR

PITCH LINE TO APERTURE FACE:

1.0850" (27.5600MM)

CAUTION: Application Approval Required for PTO Output Shaft Speeds Above 2500 RPM

PTO Model	Torq l / C †	Dir Rot	Engine %		Filler Block	Adapter Assy	Stud Kit	PTO Model	Torq l / C †	Dir Rot	Engine %		Filler Block	Adapter Assy	Stud Kit
			Fwd	Rev							Fwd	Rev			

ONE SPEED - TWO GEAR POWERSHIFT (AIR OR HYDRAULIC)

282XDAJX-*3 (22)	300 C	Opp	95		8-A-032		Furnished	272XDAJX-*3 (32)	300 C	Opp	90				Furnished
282XGAJX-*3 (23)	300 C	Opp	112		8-A-032		Furnished	272XGAJX-*3 (33)	300 C	Opp	108				Furnished
282XKAJX-*3 (24)	300 C	Opp	126		8-A-032		Furnished	272XKAJX-*3 (34)	300 C	Opp	120				Furnished
282XMAJX-*3 (25)	300 C	Opp	140		8-A-032		Furnished	272XMAJX-*3 (35)	300 C	Opp	135				Furnished
282XPAJX-*3 (26)	300 C	Opp	157		8-A-032		Furnished	272XPAJX-*3 (36)	300 C	Opp	150				Furnished
282XSAJX-*3 (27)	300 C	Opp	176		8-A-032		Furnished	272XSAJX-*3 (37)	300 C	Opp	168				Furnished
282XTAJX-*3 (28)	300 C	Opp	196		8-A-032		Furnished								

ONE SPEED - TWO GEAR - POWERSHIFT (AIR)

885XBAHX-*3 (3)	500 l	Opp	65				Furnished								
885XGAHX-*3 (8)	500 l	Opp	84				Furnished								
885XJAHX-*3 (5)	500 l	Opp	99				Furnished								
885XMAHX-*3 (6)	500 l	Opp	116				Furnished								

ONE SPEED - FORWARD & REVERSE

348XFAHX-*5 (41)	200 l	Opp	84	88			Furnished	340XFAHX-*5 (41)	200 l	Opp	80	84	7-A-140(45)		Furnished
863XBAHX-*5	423 l	Opp	65	81			Furnished								

GEARED ADAPTERS

628XAHX-3AH	250 l	Eng			8-A-032		Furnished	626XAHX-3AH	250 l	Eng					Furnished
								630XAHX-3AH	250 l	Eng					Furnished
								645XAHX-3AH	250 l	Eng					Furnished

Continued on Next Page

† l = Intermittent Torque Only - De-rate Torque Rating 30% for Continuous Duty.

C = Continuous or Intermittent Torque - No need to De-Rate Torque Rating.

IMPORTANT: Refer to the back of this transmission section and read all notes associated with this application page. Some notes may affect the proper PTO selection.

CAUTION: INPUT SIGNAL REQUIRED - In any case a PTO is used, regardless of PTO style, the transmission must have an input signal from the PTO when it is active. EATON requires the OEM to provide a "PTO Active" input connection to the transmission ECU. Refer to the Vehicle OEM for wire connection information and to Eaton TRIG2600 for Transmission/PTO Operations.

CAUTION: There is adjacent gear interference in the transmission that prevents the 489*U,W,X ratios from being used. 880*T is also affected.

CAUTION: DO NOT use geared adapters with 442 A and C ratios.

(3) Input Gear Part No. 5-P-1100	(23) Input Gear Part No. 5-P-1510-14X	(28) Input Gear Part No. 5-P-1510-19X	(36) Input Gear Part No. 5-P-1510-8X
(5) Input Gear Part No. 5-P-1102	(24) Input Gear Part No. 5-P-1510-15X	(32) Input Gear Part No. 5-P-1510-4X	(37) Input Gear Part No. 5-P-1510-9X
(6) Input Gear Part No. 5-P-1103	(25) Input Gear Part No. 5-P-1510-16X	(33) Input Gear Part No. 5-P-1510-5X	(41) Input Gear Part No. 5-P-581
(8) Input Gear Part No. 5-P-1135	(26) Input Gear Part No. 5-P-1510-17X	(34) Input Gear Part No. 5-P-1510-6X	(45) Filler block furnished with PTO
(22) Input Gear Part No. 5-P-1510-13X	(27) Input Gear Part No. 5-P-1510-18X	(35) Input Gear Part No. 5-P-1510-7X	

CHELSEA®

EATON FULLER

FLR-113

FO-16D313E-LEP (UltraShift)
FOM-16D313E-LEP (UltraShift)
RTLO-16913L-DM3 (UltraShift)
RTLOM-16913L-DM3 (UltraShift)

RIGHT SIDE ONLY

TRANSMISSION GEAR DATA:

R.S. 06-BOLT Opening Gear FORWARD of Centerline
45 Teeth - SPUR

PITCH LINE TO APERTURE FACE:

1.0850" (27.5600MM)

CAUTION: Application Approval Required for PTO Output Shaft Speeds Above 2500 RPM

PTO Model	Torq I / C †	Dir Rot	Engine %		Filler Block	Adapter Assy	Stud Kit	PTO Model	Torq I / C †	Dir Rot	Engine %		Filler Block	Adapter Assy	Stud Kit
			Fwd	Rev							Fwd	Rev			

ONE SPEED - TWO GEAR - MECHANICAL SHIFT

221XCAHX-*3	250 I	Eng	66		7-A-032(P)(20)	329138X	Furnished
221XEAHX-*3	250 I	Eng	76			329138X	Furnished
221XLAHX-*3	200 I	Eng	102			329138X	Furnished
442XAAHX-*3 (5)	250 I	Opp	58				Furnished
442XBAHX-*3 (8)	250 I	Eng	58			REQUIRED	Furnished
442XCAHX-*3 (6)	250 I	Opp	74				Furnished
442XFAHX-*3 (2)	250 I	Opp	92				Furnished
442XHAHX-*3 (7)	250 I	Opp	107				Furnished
442XLAHX-*3 (1)	250 I	Opp	119				Furnished
442XQAHX-*3 (1)	225 I	Opp	128				Furnished
442XRAHX-*3 (1)	225 I	Opp	148				Furnished
660XFAHX-*3 (3)	375 I	Opp	92				Furnished
660XHAHX-*3 (7)	330 I	Opp	107				Furnished
660XQAHX-*3 (4)	280 I	Opp	128				Furnished
660XRAHX-*3 (9)	235 I	Opp	148				Furnished

ONE SPEED - TWO GEAR POWERSHIFT (AIR OR HYDRAULIC)

272XAAJX-*3 (10)	300 C	Opp	51				Furnished
272XBAJX-*3 (11)	300 C	Opp	63				Furnished
272XCAJX-*3 (12)	300 C	Opp	76				Furnished
272XDAJX-*3 (13)	300 C	Opp	90				Furnished
272XGAJX-*3 (14)	257 C	Opp	108				Furnished
272XKAJX-*3 (15)	230 C	Opp	120				Furnished
272XMAJX-*3 (16)	206 C	Opp	135				Furnished
272XPAJX-*3 (17)	184 C	Opp	150				Furnished
272XSAJX-*3 (18)	165 C	Opp	168				Furnished

ONE SPEED - FORWARD & REVERSE

340XFAHX-*5 (19)	200 I	Opp	80	84	7-A-140(20)		Furnished
------------------	-------	-----	----	----	-------------	--	-----------

GEARED ADAPTERS

626XAHX-3AH	250 I	Eng					Furnished
-------------	-------	-----	--	--	--	--	-----------

Continued on Next Page

† I = Intermittent Torque Only - De-rate Torque Rating 30% for Continuous Duty.

C = Continuous or Intermittent Torque - No need to De-Rate Torque Rating.

IMPORTANT: Refer to the back of this transmission section and read all notes associated with this application page. Some notes may affect the proper PTO selection.

CAUTION: INPUT SIGNAL REQUIRED - The Eaton UltraShift Transmissions must have an input signal from the Power Take-Off when it is active. In this active state, the clutch engagement is controlled when the operator raises the engine speed to engage the clutch and drive the transmission main box countershaft, per EATON spec. "TRIG-2600". INCORRECT or NO PTO interface signal to the transmission will result in uncontrolled engagement of the clutch during PTO operation.

CAUTION: DO NOT use geared adapters with 442 A and C ratios.

- (1) Input Gear Part No. 5-P-1004
(2) Input Gear Part No. 5-P-1077
(3) Input Gear Part No. 5-P-1242
(4) Input Gear Part No. 5-P-1246
(5) Input Gear Part No. 5-P-1280

- (6) Input Gear Part No. 5-P-1287
(7) Input Gear Part No. 5-P-1364
(8) Input Gear Part No. 5-P-1418
(9) Input Gear Part No. 5-P-1441
(10) Input Gear Part No. 5-P-1510-1X

- (11) Input Gear Part No. 5-P-1510-2X
(12) Input Gear Part No. 5-P-1510-3X
(13) Input Gear Part No. 5-P-1510-4X
(14) Input Gear Part No. 5-P-1510-5X
(15) Input Gear Part No. 5-P-1510-6X

- (16) Input Gear Part No. 5-P-1510-7X
(17) Input Gear Part No. 5-P-1510-8X
(18) Input Gear Part No. 5-P-1510-9X
(19) Input Gear Part No. 5-P-581
(20) Filler block furnished with PTO

FLR-113

EATON FULLER

CHELSEA®

FO-16D313E-LEP (UltraShift)
FOM-16D313E-LEP (UltraShift)
RTLO-16913L-DM3 (UltraShift)
RTL0M-16913L-DM3 (UltraShift)

RIGHT SIDE ONLY

TRANSMISSION GEAR DATA:

R.S. 06-BOLT Opening Gear FORWARD of Centerline
45 Teeth - SPUR

PITCH LINE TO APERTURE FACE:

1.0850" (27.5600MM)

CAUTION: Application Approval Required for PTO Output Shaft Speeds Above 2500 RPM

PTO Model	Torq	Dir Rot	Engine %		Filler Block	Adapter Assy	Stud Kit	PTO Model	Torq	Dir Rot	Engine %		Filler Block	Adapter Assy	Stud Kit
	I / C †		Fwd	Rev					I / C †		Fwd	Rev			

GEARED ADAPTERS

630XAHX-3AH	250 I	Eng	Furnished
645XAHX-3AH	250 I	Eng	Furnished

† I = Intermittent Torque Only - De-rate Torque Rating 30% for Continuous Duty.

C = Continuous or Intermittent Torque - No need to De-Rate Torque Rating.

IMPORTANT: Refer to the back of this transmission section and read all notes associated with this application page. Some notes may affect the proper PTO selection.

CAUTION: INPUT SIGNAL REQUIRED - The Eaton UltraShift Transmissions must have an input signal from the Power Take-Off when it is active. In this active state, the clutch engagement is controlled when the operator raises the engine speed to engage the clutch and drive the transmission main box countershaft, per EATON spec. "TRIG-2600". INCORRECT or NO PTO interface signal to the transmission will result in uncontrolled engagement of the clutch during PTO operation.

CAUTION: DO NOT use geared adapters with 442 A and C ratios.

Eaton Fuller

CHELSEA®

EATON FULLER

FLR-114

EDCO-6F107A-P (Precision Series w/ Park Paw)
EDCO-6F107A-X (Precision Series)
EDCO-9N107A-P (Precision Series w/ Park Paw)
EDCO-9N107A-X (Precision Series)

LEFT SIDE ONLY

RIGHT SIDE ONLY

TRANSMISSION GEAR DATA:

L.S. 06-BOLT Opening Gear FORWARD of Centerline
23 Teeth - L.H. HELIX

PITCH LINE TO APERTURE FACE:

0.963" (24.4602MM)

TRANSMISSION GEAR DATA:

R.S. 06-BOLT Opening Gear FORWARD of Centerline
47 Teeth - R.H. HELIX

PITCH LINE TO APERTURE FACE:

1.099" (27.9146MM)

CAUTION: Application Approval Required for PTO Output Shaft Speeds Above 2500 RPM

PTO Model	Torq I / C †	Dir Rot	Engine %		Filler Block	Adapter Assy	Stud Kit	PTO Model	Torq I / C †	Dir Rot	Engine %		Filler Block	Adapter Assy	Stud Kit
			Fwd	Rev							Fwd	Rev			

ONE SPEED - TWO GEAR - MECHANICAL SHIFT

442QLLPP-*5 (1)	250 I	Eng	42				Furnished	442GLLQP-*3 (2)	250 I	Opp	99				Furnished
442QQLPP-*5 (1)	225 I	Eng	45				Furnished	442GQLQP-*3 (2)	225 I	Opp	106				Furnished
442QRLPP-*5 (1)	225 I	Eng	52				Furnished	442GRLQP-*3 (2)	225 I	Opp	123				Furnished
442QSLPP-*5 (1)	200 I	Eng	62				Furnished	442GSLQP-*3 (2)	200 I	Opp	147				Furnished
442QULPP-*5 (1)	195 I	Eng	74				Furnished	442GULQP-*3 (2)	195 I	Opp	175				Furnished
442QWLPP-*5 (1)	175 I	Eng	87				Furnished	442GWLQP-*3 (2)	175 I	Opp	205				Furnished
442QXLPP-*5 (1)	140 I	Eng	103				Furnished	442GXLQP-*3 (2)	140 I	Opp	243				Furnished

Continued on Next Page

† I = Intermittent Torque Only - De-rate Torque Rating 30% for Continuous Duty.

C = Continuous or Intermittent Torque - No need to De-Rate Torque Rating.

IMPORTANT: Refer to the back of this transmission section and read all notes associated with this application page.
Some notes may affect the proper PTO selection.

WARNING: PTO SHIFT OPTIONS - Two PTO shift options available for the Precision, (D) 12V Elec/Air or (E) 12V Elec/Hydraulic. Shift type required to interface with the TCM. The necessary 12VDC wiring harness is provided with PTO.

CAUTION: DO NOT use geared adapters with 442 A and C ratios.

(1) Input Gear Part No. 5-P-1459
(2) Input Gear Part No. 5-P-1460

FLR-115

EATON FULLER

CHELSEA®

ESO-6106

LEFT SIDE ONLY

RIGHT SIDE ONLY

TRANSMISSION GEAR DATA:

L.S. 06-BOLT Opening Gear FORWARD of Centerline
33 Teeth - R.H. HELIX

PITCH LINE TO APERTURE FACE:

1.8" (45.3MM)

TRANSMISSION GEAR DATA:

R.S. 06-BOLT Opening Gear FORWARD of Centerline
33 Teeth - R.H. HELIX

PITCH LINE TO APERTURE FACE:

1.8" (45.3MM)

CAUTION: Application Approval Required for PTO Output Shaft Speeds Above 2500 RPM

PTO Model	Torq	Dir Rot	Engine %		Filler Block	Adapter Assy	Stud Kit	PTO Model	Torq	Dir Rot	Engine %		Filler Block	Adapter Assy	Stud Kit
	I / C †		Fwd	Rev					I / C †		Fwd	Rev			

ONE SPEED - TWO GEAR - MECHANICAL SHIFT

290XQLUX-*5 (1)	175 I	Opp	94		7-A-700(P)(2)		7170-11X	290XQLUX-*3 (1)	175 I	Opp	94		7-A-700(P)(2)		7170-11X
-----------------	-------	-----	----	--	---------------	--	----------	-----------------	-------	-----	----	--	---------------	--	----------

† I = Intermittent Torque Only - De-rate Torque Rating 30% for Continuous Duty.

C = Continuous or Intermittent Torque - No need to De-Rate Torque Rating.

IMPORTANT: Refer to the back of this transmission section and read all notes associated with this application page. Some notes may affect the proper PTO selection.

(1) Input Gear Part No. 5-P-1521
(2) Furnished, but not required

CHELSEA®

EATON FULLER

FLR-116

EE-17F111B (Endurant HD)
 EEO-14F112C (Endurant HD)
 EEO-15F112C (Endurant HD)
 EEO-16F112C (Endurant HD)
 EEO-17F112C (Endurant HD)
 EEO-18F112C (Endurant HD)
 EHD-14F112C-N (Endurant CNG)

BOTTOM SIDE ONLY**REAR SIDE ONLY****TRANSMISSION GEAR DATA:**

BOT 08-BOLT Opening Gear FORWARD of Centerline
 42 Teeth - L.H. HELIX

PITCH LINE TO APERTURE FACE:

1.125" (28.575MM)

TRANSMISSION GEAR DATA:

REAR 04-BOLT Opening Gear NON-STANDARD of Centerline
 Teeth - SPUR

PITCH LINE TO APERTURE FACE:

0" (0MM)

CAUTION: Application Approval Required for PTO Output Shaft Speeds Above 2500 RPM

PTO Model	Torq I / C †	Dir Rot	Engine %		Filler Block	Adapter Assy	Stud Kit	PTO Model	Torq I / C †	Dir Rot	Engine %		Filler Block	Adapter Assy	Stud Kit
			Fwd	Rev							Fwd	Rev			

ONE SPEED - TWO GEAR - MECHANICAL SHIFT

489QCLZX-*3 (5)	200 I	Opp	94				Furnished
489QFLZX-*3 (6)	250 I	Opp	116				Furnished
489QHLZX-*3 (7)	250 I	Opp	135				Furnished
489QLLZX-*3 (1)	225 I	Opp	151				Furnished
489QQLZX-*3 (1)	225 I	Opp	162				Furnished
489QRLZX-*3 (1)	225 I	Opp	188				Furnished
680QFLZX-*3 (8)	375 I	Opp	116				Furnished
680QHLZX-*3 (9)	375 I	Opp	135				Furnished
680QRLZX-*3 (10)	350 I	Opp	188				Furnished
880QGLZX-*3 (2)	500 I	Opp	107				Furnished
880QJLZX-*3 (3)	500 I	Opp	125				Furnished
880QQLZX-*3 (4)	450 I	Opp	173				Furnished

REAR MOUNT - MECHANICAL SHIFT

511XRLZW-**	500 C	Opp	137				Furnished
524XMLZX-**	300 C	Eng	142				Furnished

† I = Intermittent Torque Only - De-rate Torque Rating 30% for Continuous Duty.

C = Continuous or Intermittent Torque - No need to De-Rate Torque Rating.

IMPORTANT: Refer to the back of this transmission section and read all notes associated with this application page. Some notes may affect the proper PTO selection.

WARNING: SHIFT OPTIONS - Two shift options are available for Endurant HD; (D) 12V Elec / Air installation kit and (V) for no installation kit included. This is for installations where the truck has the PTO prep package factory installed. Both shift types are required to interface with the TSM

CAUTION: The Endurant Transmission Control Module (TCM) must be configured for PTO operation using ServiceRanger software. The default setting for this feature is 'Disabled'. Failure to configure the TCM for PTO operation may result in transmission, PTO, or driven equipment damage. See Eaton PTO Information Guide TRIG2600 EN-US for additional information regarding this and dual (bottom + rear mount) PTO configuration.

- | | |
|----------------------------------|-----------------------------------|
| (1) Input Gear Part No. 5-P-1571 | (6) Input Gear Part No. 5-P-1588 |
| (2) Input Gear Part No. 5-P-1574 | (7) Input Gear Pa No. 5-P-1589 |
| (3) Input Gear Part No. 5-P-1575 | (8) Input Gear Part No. 5-P-1590 |
| (4) Input Gear Part No. 5-P-1577 | (9) Input Gear Part No. 5-P-1591 |
| (5) Input Gear Part No. 5-P-1587 | (10) Input Gear Part No. 5-P-1593 |

FLR-117

EATON FULLER

CHELSEA®

EA-11109LA

LEFT SIDE ONLY

RIGHT SIDE ONLY

TRANSMISSION GEAR DATA:

L.S. 06-BOLT Opening Gear FORWARD of Centerline
39 Teeth - R.H. HELIX

PITCH LINE TO APERTURE FACE:

1.097" (27.8638MM)

TRANSMISSION GEAR DATA:

R.S. 06-BOLT Opening Gear FORWARD of Centerline
39 Teeth - R.H. HELIX

PITCH LINE TO APERTURE FACE:

1.097" (27.8638MM)

CAUTION: Application Approval Required for PTO Output Shaft Speeds Above 2500 RPM

PTO Model	Torq	Dir Rot	Engine %		Filler Block	Adapter Assy	Stud Kit	PTO Model	Torq	Dir Rot	Engine %		Filler Block	Adapter Assy	Stud Kit
	I / C †		Fwd	Rev					I / C †		Fwd	Rev			

ONE SPEED - TWO GEAR - MECHANICAL SHIFT

442XQLVX-*3 (1)	225 I	Opp	83				Furnished	442XQLVX-*5 (1)	225 I	Opp	83				Furnished
-----------------	-------	-----	----	--	--	--	-----------	-----------------	-------	-----	----	--	--	--	-----------

† I = Intermittent Torque Only - De-rate Torque Rating 30% for Continuous Duty.

C = Continuous or Intermittent Torque - No need to De-Rate Torque Rating.

IMPORTANT: Refer to the back of this transmission section and read all notes associated with this application page. Some notes may affect the proper PTO selection.

(1) Input Gear Part No. 5-P-1526

Eaton Fuller

CHELSEA®

EATON FULLER

FLR-118

ESO-4106A
ESO-4206A

LEFT SIDE ONLY

TRANSMISSION GEAR DATA:

L.S. 06-BOLT Opening Gear FORWARD of Centerline
22 Teeth - R.H. HELIX

PITCH LINE TO APERTURE FACE:

1.669" (42.3926MM)

CAUTION: Application Approval Required for PTO Output Shaft Speeds Above 2500 RPM

PTO Model	Torq	Dir Rot	Engine %		Filler Block	Adapter Assy	Stud Kit	PTO Model	Torq	Dir Rot	Engine %		Filler Block	Adapter Assy	Stud Kit
	I / C †		Fwd	Rev					I / C †		Fwd	Rev			

ONE SPEED - TWO GEAR - MECHANICAL SHIFT

290XULYX-*5 (1)	175 I	Opp	66	7-A-700	7170-9X
-----------------	-------	-----	----	---------	---------

† I = Intermittent Torque Only - De-rate Torque Rating 30% for Continuous Duty.

C = Continuous or Intermittent Torque - No need to De-Rate Torque Rating.

IMPORTANT: Refer to the back of this transmission section and read all notes associated with this application page. Some notes may affect the proper PTO selection.

(1) Input Gear Part No. 5-P-1570

FLR-119

EATON FULLER

CHELSEA®

EXD-16F118D
EXD-16F118D
EXDP-16F118D
EXDP-18F118D
EXDP-20F118D

BOTTOM SIDE ONLY

REAR SIDE ONLY

TRANSMISSION GEAR DATA:

BOT 08-BOLT Opening Gear REAR of Centerline
46 Teeth - Spur

PITCH LINE TO APERTURE FACE:

.8197" (20.8204MM)

TRANSMISSION GEAR DATA:

Rear 4-Bolt Opening Gear NON STANDARD of Centerline
35 Teeth - Spur

PITCH LINE TO APERTURE FACE:

0" (0MM)

CAUTION: Application Approval Required for PTO Output Shaft Speeds Above 2500 RPM

PTO Model	Torq	Dir Rot	Engine %		Filler Block	Adapter Assy	Stud Kit	PTO Model	Torq	Dir Rot	Engine %		Filler Block	Adapter Assy	Stud Kit
	I / C †		Fwd	Rev					I / C †		Fwd	Rev			
ONE SPEED - TWO GEAR - MECHANICAL SHIFT															
489QAMEX-*6(5)	225I	Opp	70		380711X		Furnished								
489QFMEX-*6(1)	225I	Opp	111		380711X		Furnished								
489QLMEX-*6(6)	225I	Opp	144		380711X		Furnished								
489QQMEX-*6(6)	225I	Opp	155		380711X		Furnished								
489QRMEX-*6(6)	225I	Opp	180		380711X		Furnished								
680QFMEX-*6(7)	375I	Opp	111		380711X		Furnished								
680QHMEX-*6(8)	375I	Opp	129		380711X		Furnished								
680QQMEX-*6(9)	375I	Opp	155		380711X		Furnished								
880QGMEX-*4(2)	500I	Opp	112				Furnished								
880QMMEX-*4(3)	395I	Opp	155				Furnished								
880QQMEX-*4(4)	336I	Opp	181				Furnished								

REAR MOUNT - MECHANICAL SHIFT

524XMMEX-**	300C	Eng	111				Furnished
524XTMEX-**	300C	Eng	150				Furnished
524XVMEX-**	258C	Eng	200				Furnished

† I = Intermittent Torque Only - De-rate Torque Rating 30% for Continuous Duty.

C = Continuous or Intermittent Torque - No need to De-Rate Torque Rating.

IMPORTANT: Refer to the back of this transmission section and read all notes associated with this application page. Some notes may affect the proper PTO selection.

CAUTION: SHIFT OPTIONS - Only shift options for 489 and 680 series are 5 and 6, 12V Elec/Air. Only shift options for 880 series are D and V, 12V Elec/Air. Shift type required to interface with the TCM. The necessary 12V wiring harness is provided with 6 and D shift options.

CAUTION: The Endurant Transmission Control Module (TCM) must be configured for PTO operation using ServiceRanger software. The default setting for this feature is 'Disabled'. Failure to configure the TCM for PTO operation may result in transmission, PTO, or driven equipment damage. See Eaton PTO Information Guide TRIG2600 EN-US for additional information regarding this and dual (bottom + rear mount) PTO configuration.

CAUTION: 489 and 680 series PTO's require the use of 380711X spacer plate for mounting to the transmission. The spacer plate is assembled between the PTO and transmission. See SK-672 for details. The spacer plate is included with the PTO. It does not need to be ordered separately.

CAUTION: Eaton Transmission Division has established a maximum torque limit for the transmission driver gear. For all Endurant XD transmissions the torque limit is as follows: 8-Bolt Bottom Mount - 555 lb-ft (745 Nm) continuous, Rear Mount - 555 lb-ft (745 Nm) continuous, Combined - 555 lb-ft (745 Nm) continuous.

CAUTION: 524 Series - External lubrication is required for this application. Lubrication kit 330085X is furnished with the PTO. Failure to install the lubrication kit prior to PTO start up may cause damage to the PTO and/or transmission. See SK-677 for details

(1) Input Gear Part No. 5-P-1688
(2) Input Gear Part No. 5-P-1670
(3) Input Gear Part No. 5-P-1671
(4) Input Gear Part No. 5-P-1672
(5) Input Gear Part No. 5-P-1702

(6) Input Gear Part No. 5-P-1703
(7) Input Gear Part No. 5-P-1705
(8) Input Gear Part No. 5-P-1706
(9) Input Gear Part No. 5-P-1707

Eaton Fuller Notes

FLR-34

1. The AK & XK output flanges can not be used with the A & C ratios on the 489 Series PTOs due to mounting stud interference. Use a RA or RB rotatable flange for the XK and the RA for the AK flange.
 2. The 442XBAH must use one of the GEARED ADAPTERS listed on the application page. The direction of rotation shown is the final output shaft rotation w/ geared adapter.
 3. 272/282 Series - Must be used as an AIR Shift PTO. Order Air Shift Options Only
-

FLR-40

1. All PTOs on RH side require assembly arrangement 6 to put output shaft above center. This will clear the bulge in the transmission. A direct mount pump will interfere with the bulge.
 2. The AK & XK output flanges can not be used with the A & C ratios on the 489 Series PTOs due to mounting stud interference. Use a RA or RB rotatable flange for the XK and the RA for the AK flange.
-

FLR-41

1. All PTOs on R.H. side require assembly arrangement 6 to put output shaft above center. This will clear the bulge in the transmission. A direct mount pump will interfere with the bulge.
 2. The AK & XK output flanges can not be used with the A & C ratios on the 489 Series PTOs due to mounting stud interference. Use a RA or RB rotatable flange for the XK and the RA for the AK flange.
-

FLR-57

1. The AK & XK output flanges can not be used with the A & C ratios on the 489 Series PTOs due to mounting stud interference. Use a RA or RB rotatable flange for the XK and the RA for the AK flange.
 2. The 442XBAH must use one of the geared adapters listed on the application page. The direction of rotation shown is the final output shaft rotation w/ geared adapter.
 3. 272/282 Series - Must be used as an AIR Shift PTO. Order Air Shift Options Only
-

FLR-58

1. The 880 Series T ratio will interfere with the adjacent gear in the transmission on the bottom opening.
 2. The 489 Series ratios U, W, & X will interfere with the adjacent gear in the transmission on the bottom opening. The 442 Series ratios S, U, W and X will interfere with the adjacent gear in the transmission on the right opening.
 3. The AK & XK output flanges can not be used with the A & C ratios on the 489 Series PTOs due to mounting stud interference. Use a RA or RB rotatable flange for the XK and the RA for the AK flange.
 4. The 442XBAH Must Use One of the Geared Adapters Listed on the Application Page. Direction of Rotation Shown is the Final Output Shaft Rotation w/ Geared Adapter.
 5. 272/282 Series - Must be used as an AIR Shift PTO. Order Air Shift Options Only
-

FLR-59

1. The AK & XK output flanges can not be used with the A & C ratios on the 489 Series PTOs due to mounting stud interference. Use a RA or RB rotatable flange for the XK and the RA for the AK flange.
 2. The 442XBAH must use one of the geared adapters listed on the application page. The direction of rotation shown is the final output shaft rotation w/ geared adapter.
 3. 272/282 Series - Must be used as an AIR Shift PTO. Order Air Shift Options Only
-

FLR-60

1. The AK & XK output flanges can not be used with the A & C ratios on the 489 Series PTO due to mounting stud interference. Use a RA or RB rotatable flange for the XK and the RA for the AK flange.
-

FLR-64

1. The AK & XK output flanges can not be used with the A & C ratios on the 489 Series PTOs due to mounting stud interference. Use a RA or RB rotatable flange for the XK and the RA for the AK flange.
 2. The 442XBAH must use one of the geared adapters listed on the application page. The direction of rotation shown is the final output shaft rotation w/ geared adapter.
 3. 272/282 Series - Must be used as an AIR Shift PTO. Order Air Shift Options Only
-

Eaton Fuller Notes

FLR-66

1. The AK & XK output flanges can not be used with the A & C ratios on the 489 Series PTOs due to mounting stud interference. Use a RA or RB rotatable flange for the XK and the RA for the AK flange.
 2. The 442XBAH must use one of the geared adapters listed on the application page. The direction of rotation shown is the final output shaft rotation w/ geared adapter.
 3. 272/282 Series - Must be used as an AIR Shift PTO. Order Air Shift Options Only
-

FLR-68

1. 511 Rear Mount-The adapter 329748X is furnished with the PTO and does not need to be ordered separately.
 2. 272/282 Series - Must be used as an AIR Shift PTO. Order Air Shift Options Only
 3. 272 Series PTO cannot be used with a geared adapter on this application page. There is no counter-helical gear to mesh with the adapter.
-

FLR-69

1. Do not use PTOs that have a sliding Input Driver Gear (i.e. 221, 260)
 2. 272/282 Series - Must be used as an AIR Shift PTO. Order Air Shift Options Only
-

FLR-75

1. Do not use PTOs that have a sliding Input Driver Gear (i.e. 221, 260)
 2. RECOMMENDATION - Use assembly arrangement 5 on RH side. With assembly arrangement 3, there may be interference with the output shaft of the PTO and the rear cover on the transmission.
-

FLR-77

1. The 442/489 S, U, W, and X ratio gears interfere with the outside diameter of the 78 tooth transmission gear.
-

FLR-78

1. This application is for model FS-3005A AFTER September, 1988. For applications PRIOR to September, 1988, use application no. FLR-74.
 2. Do not use PTOs that have a sliding Input Driver Gear (i.e. 221, 260)
-

FLR-79

1. This application is for model FS-3005B AFTER September, 1988. For applications PRIOR to September, 1988, use application no. FLR-76.
-

FLR-84LF

1. 511 Rear Mount - The adapter 329733X is furnished with the PTO
 2. There are two SAE 6-Bolt pads on the left side of this transmission.
 3. The 272 and 442 Series will mount with the 329182-1X adapter on the front opening only.
 4. 272/282 Series - Must be used as an AIR Shift PTO. Order Air Shift Options Only
-

FLR-87

1. PTO apertures on these transmissions may be on the left side (vertical installation) or the bottom right (horizontal installation), depending on how the transmission is mounted in the truck. These transmissions have two apertures, the 290 Series will only mount on the front aperture.
 2. 511 Rear Mount - The adapter 329768X is furnished with the PTO and does not need to be ordered separately
-

FLR-88

1. The 442 U, W and X ratios will not mount on the right side and the 489 X ratio will not mount on the bottom opening because the O.D. of the ratio gear hits the O.D. of the adjacent gear in the transmission.
2. 328564G comes with a metric stud kit. The PTO must be fastened to the adapter plate with the standard stud kit that comes with the PTO.
3. 272/282 Series - Must be used as an AIR Shift PTO. Order Air Shift Options Only

Eaton Fuller Notes

FLR-90

1. The Fuller C2000 Series (FR Series) transmissions have M10-1.5 threads for the 6-Bolt opening and M12-1.75 threads for the 8-Bolt opening.
2. 272/282 Series - Must be used as an AIR Shift PTO. Order Air Shift Options Only

FLR-91

1. The Fuller C2000 Series (FR Series) transmissions have M10-1.5 threads for the 6-Bolt opening and M12-1.75 threads for the 8-Bolt opening.
2. 272/282 Series - Must be used as an AIR Shift PTO. Order Air Shift Options Only

FLR-92

1. The EH Series Transmissions (Hybrid Electric) for Medium-Duty Utility, Telecom and Municipal Applications are Limited by Eaton to only ONE (1) PTO per application. The Right (Curb Side) Transmission PTO Aperture Cover Plate has a Speed Sensor mounted to the plate and can be moved to the Left (Street Side) Transmission PTO Aperture if using the Right Side PTO Aperture. SEE FLR-92HY.
2. FO-8406A-ASX, FO-6406A-ASX and FO-6406A-ASW Left Side not usable due to Inertia Brake mounted to the 6-Bolt opening.
3. The 7-A-187 spacer and 7170-3X stud kit are required to mount the 442 Series to the adapter.
4. 511 Rear Mount - The adapter 329748X is furnished with the PTO and does not need to be ordered separately
5. 272/282 Series - Must be used as an AIR Shift PTO. Order Air Shift Options Only

FLR-92HY

1. PTO (Battery Driven) Only Available with EH-8E306A-UP and Can Not Be Used In Combination with the Mechanical PTO.
2. Motor RPM During PTO Operation is 1000-1100 RPM Standard. Configurable to 1500 RPM in 100 RPM Increments.
3. Maximum PTO Output Must Not Exceed 13 HP Continuous or 26 HP Peak at 1100 RPM for Maximum Efficiency.
4. All PTO Application Duty Cycles Must be Evaluated for Optimum Efficiency.
5. Mechanical (Engine/Transmission Driven) PTO is Available with EH-8E306A-CD, EH-8E306A-UP, EH8E306A-UPG.
6. Remote Throttle, Remote Transmission, and Start/Stop Controls are Not Approved.
7. The EH Series Transmissions (Hybrid Electric) for Medium-Duty Utility, Telecom and Municipal Applications are Limited by Eaton to only ONE (1) PTO per application. The Right (Curb Side) Transmission PTO Aperture Cover Plate has a Speed Sensor mounted to the plate and can be moved to the Left (Street Side) Transmission PTO Aperture if using the Right Side PTO Aperture.
8. 272/282 Series - Must be used as an AIR Shift PTO. Order Air Shift Options Only

FLR-94

1. 7-A-062 is required to mount the PTO at standard mounting depth of 1.085" due to the transmission gear tooth thickness that is 0.065" oversize.
2. 272/282 Series - Must be used as an AIR Shift PTO. Order Air Shift Options Only

FLR-95

1. When using a 626G/630G or 645G adapter on this transmission, put 5-P-1243 gear in the adapter and the 5-P-1247 gear in the 442 Series PTO 7-A-165 spacer is required between the adapter and the 442 Series. Normal backlash will need to be checked between the PTO and the adapter. Use stud kit 7170-3X to mount the 442 Series to the Adapter.

FLR-96LF

1. There are two SAE 6-Bolt pads on the left side of this transmission.
2. The 230 and 442 series will mount with the 329182-1X adapter on the front opening only. The 272 Series will mount with the 329182X adapter on the front opening only.
3. 511 Rear Mount - The adapter 329733X is furnished with the PTO and does not need to be ordered separately
4. 272/282 Series - Must be used as an AIR Shift PTO. Order Air Shift Options Only

Eaton Fuller Notes

FLR-97

1. The 626 and 645 Series adapters can not be used with the 442 Series F ratio.
2. The 626/645 Series adapters can be mounted on this transmission by replacing the 5-P-1319 gear in the 442 Series with the 5-P-1321 and putting the 5-P-1319 gear in the adapter assembly. A 7-A-093 spacer is required between the adapter and the PTO to get proper backlash. Use 7170-3X stud kit to mount the PTO to the adapter. Use the stud kit supplied with the adapter to mount it to the transmission.
3. 272/282 Series - Must be used as an AIR Shift PTO. Order Air Shift Options Only

FLR-100

1. 630-02 - The Eaton Inertia Brake comes standard mounted on the bottom 8-Bolt opening. If the 8-Bolt opening is required for a PTO the Inertia Brake can be relocated to the right side 6-Bolt opening. If there is any interference (frame rails, etc.) on the right side when mounting the Inertia Brake, a 630-02 adapter can be used to move the I-Brake away from the interference.
2. Refer to Eaton Installation Guide "TRIG-2600" for proper wiring diagram showing the interface connections between the PTO indicator switch and the terminal connection on the transmission.
3. The 442XBAH must use one of the geared adapters listed on the application page. The direction of rotation shown is the final output shaft rotation w/ geared adapter.
4. 272/282 Series - Must be used as an AIR Shift PTO. Order Air Shift Options Only
5. INPUT SIGNAL REQUIRED - The Eaton UltraShift DM transmission must have an input signal from the Power Take-Off when it is active. In this active state, the clutch engagement is controlled when the operator raises the engine speed to engage the clutch and drive the transmission main box countershaft. Minimum engine/transmission speed required for PTO operation is 1000 RPM, per Eaton spec. "TRIG-2600". INCORRECT or NO PTO interface signal to the transmission will result in uncontrolled engagement of the clutch during PTO operation.

FLR-105

1. The 442XBAH must use one of the geared adapters listed on the application page. The direction of rotation shown is the final output shaft rotation w/ geared adapter.
2. Optional front mount oil filter will interfere with 6-Bolt PTO installations. Rear or remote mount filter must be used.
3. All PTO Torque Values Reflect the Higher Torque 750 lb-ft [1017 Nm] Main Transmission Input Bearing for Intermittent Duty Cycles as Standard from Eaton for the Transmissions Listed for this Page. For Continuous Duty Cycles do not exceed 500 lb-ft [678 Nm]. Refer to the Chelsea PTO Torque Limit Chart in the front of this section for complete torque limit information.
4. 272/282 Series - Must be used as an AIR Shift PTO. Order Air Shift Options Only
5. 630-02 - The Eaton Inertia Brake comes standard mounted on the bottom 8-Bolt opening. If the 8-Bolt opening is required for a PTO, the Inertia Brake can be relocated to the right side 6-Bolt opening. If there is any interference (frame rails, etc.) on the right side when mounting the Inertia Brake, a 630-02 adapter can be used to move the I-Brake away from the interference.

FLR-106

1. All PTO Torque Values Reflect the Higher Torque 750 lb-ft [1017 Nm] Main Transmission Input Bearing for Intermittent Duty Cycles as Standard from Eaton for the Transmissions Listed for this Page. For Continuous Duty Cycles do not exceed 500 lb-ft [678 Nm]. Refer to the Chelsea PTO Torque Limit Chart in the front of this section for complete torque limit information.
2. 630-02 - The Eaton Inertia Brake comes standard mounted on the bottom 8-Bolt opening. If the 8-Bolt opening is required for a PTO, the Inertia Brake can be relocated to the right side 6-Bolt opening. If there is any interference (frame rails, etc.) on the right side when mounting the Inertia Brake, a 630-02 adapter can be used to move the I-Brake away from the interference.
3. The 442XBAH must use one of the geared adapters listed on the application page. The direction of rotation shown is the final output shaft rotation w/ geared adapter.
4. Eaton Fuller will provide a dump pump bracket (Eaton Part #4306528) as standard on -VCS, -VMS and -VXP transmission models for the bottom 8-Bolt opening and optional on -LAS,-MHP and -MXP model transmissions.
5. 272/282 Series - Must be used as an AIR Shift PTO. Order Air Shift Options Only

Eaton Fuller Notes

FLR-107

1. All PTO Torque Values Reflect the Higher Torque 750 lb-ft [1017 Nm] Main Transmission Input Bearing for Intermittent Duty Cycles as Standard from Eaton for the Transmissions Listed for this Page. For Continuous Duty Cycles do not exceed 500 lb-ft [678 Nm]. Refer to the Chelsea PTO Torque Limit Chart in the front of this section for complete torque limit information.
2. The Eaton UltraShift Plus Transmission Inertia Brake comes standard and is internal to the transmission.
3. Eaton Automated 13 and 18 speeds cannot accept the Thrushaft Power Take-Offs. The bottom left countershaft opening is used for the splitter cylinder and the top right countershaft opening is used for the range.
4. 6-Bolt PTO will interfere with front mount oil filter. Rear or remote mount filter must be used
5. The 442XBAH must use one of the geared adapters listed on the application page. The direction of rotation shown is the final output shaft rotation w/ geared adapter.
6. Eaton Fuller will provide a dump pump bracket (Eaton Part #4306528) as standard on -VCS, -VMS, and -VXP transmission models for the bottom 8-Bolt opening and optional on -LAS, -MHP, and -MXP model transmissions. Refer to the Chelsea PTO Torque Limit Chart in the front of this section for complete torque limit information.
7. 272/282 Series - Must be used as an AIR Shift PTO. Order Air Shift Options Only

FLR-111

1. All PTO Torque Values Reflect the Higher Torque 750 lb-ft [1017 Nm] Main Transmission Input Bearing for Intermittent Duty Cycles as Standard from Eaton for the Transmissions Listed for this Page. For Continuous Duty Cycles do not exceed 500 lb-ft [678 Nm] refer to the Chelsea PTO Torque Limit Chart in the front of this section for complete torque limit information.
2. Refer to Eaton Installation Guide "TRIG-2600" for proper wiring diagram showing the interface connections between the PTO indicator switch and the terminal connection on the transmission.
3. 630-02 - The Eaton Inertia Brake comes standard mounted on the bottom 8-Bolt opening. If the 8-Bolt opening is required for a PTO, the Inertia Brake can be relocated to the right side 6-Bolt opening. If there is any interference (frame rails, etc.) on the right side when mounting the Inertia Brake, a 630-02 adapter can be used to move the I-Brake away from the interference.
4. The 442XBAH must use one of the geared adapters listed on the application page. The direction of rotation shown is the final output shaft rotation w/ geared adapter.
5. 6-Bolt PTO will interfere with front mount oil filter. Rear or remote mount filter must be used
6. 272/282 Series - Must be used as an AIR Shift PTO. Order Air Shift Options Only

FLR-112

1. All PTO Torque Values Reflect the Higher Torque 750 lb-ft [1017 Nm] Main Transmission Input Bearing for Intermittent Duty Cycles as Standard from Eaton for the Transmissions Listed for this Page. For Continuous Duty Cycles do not exceed 500 lb-ft [678 Nm]. Refer to the Chelsea PTO Torque Limit Chart in the front of this section for complete torque limit information.
2. Eaton Automated 13 and 18 speeds cannot accept the Thrushaft Power Take-Offs. The bottom left countershaft opening is used for the splitter cylinder and the top right countershaft opening is used for the range.
3. Optional front mount oil filter will interfere with 6-Bolt P.T.O installations. Rear or remote mount filter must be used.
4. The 442XBAH must use one of the geared adapters listed on the application page. The direction of rotation shown is the final output shaft rotation w/ geared adapter.
5. 272/282 Series - Must be used as an AIR Shift PTO. Order Air Shift Options Only

FLR-113

1. UltraShift 13-Speeds DM3, LHP & LEP: Inertia brake is installed on the 8-Bolt Opening. Inertia brake cannot be moved to the 6-Bolt Opening due to gear interference.
2. Eaton Automated 13 and 18 speeds cannot accept the Thrushaft Power Take-Offs. The bottom left countershaft opening is used for the splitter cylinder and the top right countershaft opening is used for the range.
3. 6-Bolt PTO will interfere with front mount oil filter. Rear or remote mount filter must be used
4. The 442XBAH Must Use One of the Geared Adapters Listed on the Application Page. Direction of Rotation Shown is the Final Output Shaft Rotation w/ Geared Adapter.
5. 272 Series - Must be used as an AIR Shift PTO. Order Air Shift Options Only

Eaton Fuller Notes

FLR-114

1. Percent (%) of Engine Speed shown on page applies to Stationary Mode and Mobile Mode when transmission is in 2nd Gear.
 2. Multiply Speed Shown by 0.64 for "Low" Range Values, Low Range applies to Mobile Mode ONLY when transmission is in Reverse or 1st gear.
 3. Lube hose and fittings included with PTO.
 4. Pressure lubrication of the 442 Series in this application is recommended by Eaton, but not required. Chelsea recommends and encourages the use of pressure lubrication to provide the best performance and service life. Therefore, this application is specified as "P" lube and the hoses are included with the PTO. Low Pressure (LP) lubrication supply port is located on drivers side transmission.
 5. PUMP OUTPUT OPTIONS: Chelsea recommends rotatable SAE B options (RA/RB) for the left side opening. An XK will work for a 2-Bolt pump with a modification to the flange. The right side appears to be open.
-

FLR-116

1. Gaskets are replaced by a custom molded o-ring. No backlash setting required. Special piloting studs are included in lieu of dowel pins.
 2. 880 Series - The D shift option must be used for new applications. A 4-way air valve will be provided with the D-shift option that will supply air to both sides of the shifter. The factory dash switch cannot be used with the 880 since the factory air valve is only a 3-way valve. The V shift option can be used for replacement PTOs.
 3. The AK & XK output flanges can not be used with the A & C ratios on the 489 Series PTOs due to mounting stud interference. Use a RA or RB rotatable flange for the XK and the RA for the AK flange.
 4. 511 Series - Adapter 329957X Furnished with PTO for this application.
 5. 524 Series - Adapter 329971X Furnished with PTO for this application.
-

FLR-117

1. Inertia Brake located on the transmission left side PTO aperture.

FORD



Parker | Chelsea

ENGINEERING **YOUR** SUCCESS.

**WARNING — User Responsibility**

FAILURE OR IMPROPER SELECTION OR IMPROPER USE OF THE PRODUCTS DESCRIBED HEREIN OR RELATED ITEMS CAN CAUSE DEATH, PERSONAL INJURY AND PROPERTY DAMAGE.

This document and other information from Parker Hannifin Corporation, its subsidiaries and authorized distributors provide product or system options for further investigation by users having technical expertise.

The user, through its own analysis and testing, is solely responsible for making the final selection of the system and components and assuring that all performance, endurance, maintenance, safety and warning requirements of the application are met. The user must analyze all aspects of the application, follow applicable industry standards, and follow the information concerning the product in the current product catalog and in any other materials provided from Parker or its subsidiaries or authorized distributors.

To the extent that Parker or its subsidiaries or authorized distributors provide component or system options based upon data or specifications provided by the user, the user is responsible for determining that such data and specifications are suitable and sufficient for all applications and reasonably foreseeable uses of the components or systems.

Offer of Sale

The items described in this document are hereby offered for sale by Parker Hannifin Corporation, its subsidiaries or its authorized distributors. This offer and its acceptance are governed by the provisions stated in the "Offer of Sale".



WARNING: This product can expose you to chemicals including Lead and Lead Compounds, and Di(2-ethylhexyl)phthalate (DEHP) which are known to the State of California to cause cancer and birth defects or other reproductive harm. For more information go to www.P65Warnings.ca.gov

© Copyright 2022, Parker Hannifin Corporation, All Rights Reserved

Transmission Make and Model	PTO Appl. Number	Number Forward Speeds	Teeth in PTO Driver
10R140 Diesel F250-600; MY2020-Current	FRD-13	10	L46
10R140 Gas F250-600; MY2020-Current	FRD-14	10	L46
5R110 Diesel F350-550; MY2003-2010 (Stationary ONLY)	FRD-9	5	L121
5R110 Gas F350-550; MY2003-2016 (Stationary ONLY)	FRD-9	5	L121
5R110WOJ233 (Ford Mexico)	FRD-9	5	L121
6R140 Diesel F250-550; MY2011-MY2019	FRD-10	6	L52
6R140 Diesel F650/750; MY2016-Current	FRD-10	6	L52
6R140 Gas F250-550; MY2017-MY2019	FRD-12	6	L52
6R140 Gas F650/750; MY2013-2015	FRD-11	6	L52
6R140 Gas F650/750; MY2016-Current	FRD-12	6	L52



IMPORTANT: See Safety Information in Section 1 of the Chelsea Applications catalog HY25-3000/US

Transmission PTO Driver & Apertures (Viewed from Rear of Transmission)
L-Left Side R-Right Side B-Bottom Side T-Top Side CS-Countershaft
For transmissions not listed, contact your authorized Chelsea Distributor.

FRD-9

FORD

CHELSEA®

5R110WOJ233 (Ford Mexico)
5R110 Diesel F350-550; MY2003-2010 (Stationary ONLY)
5R110 Gas F350-550; MY2003-2016 (Stationary ONLY)

LEFT SIDE ONLY

TRANSMISSION GEAR DATA:

L.S. 06-BOLT Opening Gear REAR of Centerline
121 Teeth - SPUR

PITCH LINE TO APERTURE FACE:

1.3390" (33.7800MM)

CAUTION: Application Approval Required for PTO Output Shaft Speeds Above 2500 RPM

PTO Model	Torq	Dir Rot	Engine %		Filler Block	Adapter Assy	Stud Kit	PTO Model	Torq	Dir Rot	Engine %		Filler Block	Adapter Assy	Stud Kit
	I / C †		Fwd	Rev					I / C †		Fwd	Rev			
ONE SPEED - TWO GEAR - POWERSHIFT (HYDRAULIC)															

247FMKSP-*2 (1)	120 I	Opp	154				Furnished
247FMKSP-*4 (1)	120 I	Opp	154				Furnished

† I = Intermittent Torque Only - De-rate Torque Rating 30% for Continuous Duty.

C = Continuous or Intermittent Torque - No need to De-Rate Torque Rating.

IMPORTANT: Refer to the back of this transmission section and read all notes associated with this application page. Some notes may affect the proper PTO selection.

WARNING: To guarantee full torque capability at the automatic transmission PTO gear, and the PTO, the TorqShift transmission torque converter must be locked (Engine RPM @ 1200 RPM), and hydraulic line pressure to the PTO clutch must be elevated to a minimum of 110 psi. On both Diesel and Gas engines, the Stationary Elevated Idle Control (SEIC) strategy is 1200 RPM. Therefore, for stationary operations, a discrete signal, which is supplied with Chelsea 247 wire harness 329598X, must be used to elevate engine idle to a minimum of 1200 RPM. Battery voltage must be applied to the PTO circuit to begin SEIC strategy for both mobile and stationary applications. Failure to follow these procedures may lead to PTO clutch wear and internal damage to the PTO/Transmission. See Chelsea Owner's/Installation Manual HY25-1FRD-M1/US or Contact Chelsea Technical Services (662-895-1052) for complete details.

(1) Input Gear Part No. 5-P-1387

Ford

6R140 Diesel F250-550; MY2011-MY2019
6R140 Diesel F650/750; MY2016-Current

LEFT SIDE ONLY

TRANSMISSION GEAR DATA:
L.S. 06-BOLT Opening Gear FORWARD of Centerline
52 Teeth - SPUR
PITCH LINE TO APERTURE FACE:
3.4550" (87.7640MM)

CAUTION: Application Approval Required for PTO Output Shaft Speeds Above 2500 RPM

PTO Model	Torq	Dir Rot	Engine %		Filler Block	Adapter Assy	Stud Kit	PTO Model	Torq	Dir Rot	Engine %		Filler Block	Adapter Assy	Stud Kit
	I / C †		Fwd	Rev					I / C †		Fwd	Rev			

ONE SPEED - TWO GEAR - POWERSHIFT (HYDRAULIC)

249FMLLX-*2 (1)	200 I	Opp	124				Furnished
249FMLLX-*4 (1)	200 I	Opp	124				Furnished
249FMLLX-*V (1)	200 I	Opp	124				Furnished
272FCLLP-*8	300 I	Opp	61				Furnished
272FDLLP-*8	300 I	Opp	74				Furnished
272FGLLP-*8	300 I	Opp	87				Furnished
272FKLLP-*8	300 I	Opp	98				Furnished
272FMLLP-*8	274 I	Opp	109				Furnished
272FPLLP-*8	246 I	Opp	122				Furnished
272FSLLP-*8	220 I	Opp	137				Furnished

See next page for more pump options.

Continued on Next Page

† I = Intermittent Torque Only - De-rate Torque Rating 30% for Continuous Duty. C = Continuous or Intermittent Torque - No need to De-Rate Torque Rating.

IMPORTANT: Refer to the back of this transmission section and read all notes associated with this application page. Some notes may affect the proper PTO selection.

WARNING: If any Chelsea PTO is purchased without a Chelsea supplied activation switch, warning light, and warning light installation instructions, which are normally included with the PTO, it is the full responsibility of the installer to ensure the PTO is properly installed and electrically interfaced with the OE truck communication system. The installer assumes full responsibility for warning the operator of the truck that the PTO is engaged or disengaged. Failure to adequately warn the operator could result in death, personal injury, and/or property damage.

CAUTION: FORD PTO Driver Gear Torque ratings and HP vary by platform (F250-550 or F650/750), fuel type (Gas or Diesel), and operating mode (Mobile or Stationary). Consult FORD BBAS for the current ratings. The applications on this page are rated for Stationary Mode.

CAUTION: 272 will only fit F650/750 chassis, not for use on F550 and below.

(1) Input Gear Part No. 5-P-1436



FRD-10

FORD

CHELSEA®

6R140 Diesel F250-550; MY2011-MY2019
6R140 Diesel F650/750; MY2016-Current

LEFT SIDE ONLY

TRANSMISSION GEAR DATA:

L.S. 06-BOLT Opening Gear FORWARD of Centerline
52 Teeth - SPUR

PITCH LINE TO APERTURE FACE:

3.4550" (87.7640MM)

Pump Option Charts

249 Series Gear Pump Options

Chelsea CGP-P11 Series Pump Specs for 4 x 2 and 4 x 4 Vehicles (3/4" - 11 Tooth Pump Spline - AD Output)

Order Code w/ PTO (C)	Chelsea Pump Model	Displacement in ³ /rev	GPM (A)	Pump (A) HP	Torque (A) lb-ft	Pressure PSI		Max Speed RPM		Max Pump Flow GPM
						Intermittent	Continuous	Pump	Engine (B)	
16	CGP-P11A016-5GC	0.37	2.15	4.5	16.0	3990	3625	4000	2016	3.6
26	CGP-P11A026-5GC	0.61	3.54	7.5	26.4	3990	3625	3600	2016	5.9
32	CGP-P11A032-5GC	0.73	4.23	9.0	31.6	3990	3625	3500	2016	7.1
37	CGP-P11A037-5GC	0.85	4.93	10.4	36.8	3990	3625	3300	2016	8.3
42	CGP-P11A042-5GC	0.98	5.68	12.0	42.4	3990	3625	3000	2016	9.5
55	CGP-P11A055-5GC	1.28	7.42	14.8	52.1	3480	3410	2800	2016	12.5
61	CGP-P11A061-5GE	1.40	8.12	15.5	54.6	3410	3265	2800	2016	13.6
71	CGP-P11A071-5GE	1.65	9.57	15.4	54.3	2900	2755	2400	1935	15.4
82	CGP-P11A082-5GE	1.89	10.96	15.3	54.0	2465	2395	2300	1855	16.9
87	CGP-P11A087-5GE	2.01	11.65	15.3	54.0	2320	2250	2000	1613	15.7

Chelsea PGP-315 Series Pump Specs for 4 x 2 Vehicles Only (3/4" - 11 Tooth Pump Spline - AD Output)

Order Code w/ PTO	Chelsea Pump Model	Displacement in ³ /rev	GPM (A)	Pump (A) HP	Torque (A) lb-ft	Pressure PSI		Max Speed RPM		Max Pump Flow GPM
						Intermittent	Continuous	Pump	Engine (B)	
08	CGP-P31B081-5AG	1.86	10.78	20.8	73.3	3300	3300	3000	2016	18.1
09	CGP-P31B094-5AG	2.17	12.58	21.3	75.1	2900	2900	3000	2016	21.1
11	CGP-P31B107-5AG	2.48	14.38	21.0	74.0	2500	2500	3000	2016	24.2

Chelsea P16 Series Pump Specs for 4 x 2 Vehicles Only (7/8" - 13 Tooth Pump Spline - XP Output)

Order Code w/ PTO	Chelsea Pump Model	Displacement in ³ /rev	GPM (A)	Pump (A) HP	Torque (A) lb-ft	Pressure PSI		Max Speed RPM		Max Pump Flow GPM
						Intermittent	Continuous	Pump	Engine (B)	
15	CGP16-150A-2D1	2.93	16.99	29.7	104.9	3000	3000	2800	2016	28.5

(A) GPM & Pump Input HP @ 1200 Engine RPM (1488 PTO Output RPM - 124% Ratio) & Continuous Pressure Rating with 90% efficiency rating considered.

(B) Max Engine Speed = (Max Pump Speed) / (1.24) for PTO Ratio Increase. Max Speed determined by Max PTO output speed of 2500.

(C) For Pump Codes 61, 71, 82 & 87 - 45 degree fittings are required to connect hydraulic hoses for clearance. Order Kit number 329667X

CAUTION: 249 Gear Pump Options: The PTO drive gear delivers up to 250 lb-ft torque to the aftermarket PTO, and can manage the heat of 60 HP continuously. Higher horsepower can be delivered, but for shorter durations depending on the amount of power required. Ref: Ford Body Builders Manual; TorqShift Automatic Transmission.

FORMULAS:

GPM = Cu. In. x .004329 = G/Rev x 1488 RPMs x .90 efficiency

HP = (GPM x Max PSI) / 1714

Torque = (HP x 5252) / 1488 RPMs

Ford

6R140 Diesel F250-550; MY2011-MY2019
6R140 Diesel F650/750; MY2016-Current

LEFT SIDE ONLY

TRANSMISSION GEAR DATA:
L.S. 06-BOLT Opening Gear FORWARD of Centerline
52 Teeth - SPUR
PITCH LINE TO APERTURE FACE:
3.4550" (87.7640MM)

Pump Option Charts

249 Series Gear Pump Options

Chelsea 249V Integral Vane Pump Data for 4 x 2 or 4 x 4 Vehicles

Option Code w/ PTO	Chelsea Pump Cartridge Number	Displacement in ³ /rev	GPM (D)	Pump (D) HP	Torque (D) lb-ft	Pressure PSI		Pump Speed RPM		Max Speed RPM Engine (B)
						Intermittent	Continuous	Min.	Max.	
08	380418-08	1.61	9.33	19	67	4000	3500	400	2800	2015
10	380418-10	2.08	12.06	25	87	4000	3500	400	2800	2015
12	380418-12	2.26	13.10	27	94	4000	3500	400	2800	2015
14	380418-14	2.81	16.29	33	117	4000	3500	400	2800	2015
17	380418-17	3.56	20.64	42	149	4000	3500	400	2800	2015
20	380418-20	3.89	22.55	46	163	4000	3500	400	2800	2015
22	380418-22	4.29	24.87	51	179	4000	3500	400	2800	2015
25	380418-25	4.84	28.06	57	202	4000	3500	400	2800	2015
157	380418-157					4000	3500	400	2800	2015

(A) GPM & Pump Input HP @ 1200 Engine RPM (1488 PTO Output RPM - 124% Ratio) & Continuous Pressure Rating with 90% efficiency rating considered.
 (B) Max Engine Speed = (Max Pump Speed) / (1.24) for PTO Ratio Increase. Max Speed determined by Max PTO output speed of 2500.
 (D) GPM & Pump Input HP @ 1200 Engine RPM (1488 PTO Output RPM - 124% Ratio) & 2000 PSI Continuous Pressure Rating.
 See leakage chart for additional flow losses at other pressures.
CAUTION: 249V Pump Options: The PTO drive gear delivers up to 250 lb-ft torque to the aftermarket PTO, and can manage the heat of 40 HP continuously. Higher horsepower can be delivered, but for shorter durations depending on the amount of power required. Ref: Ford Body Builders Manual; TorqShift Automatic Transmission.
NOTE: Refer to Chelsea Owner's Manual HY25-1FRD-M1/US for complete vane pump information.

FORMULAS:
 GPM = Cu. In. x .004329 = G/Rev x 1488 RPMs x .90 efficiency
 HP = (GPM x Max PSI) / 1714
 Torque = (HP x 5252) / 1488 RPMs

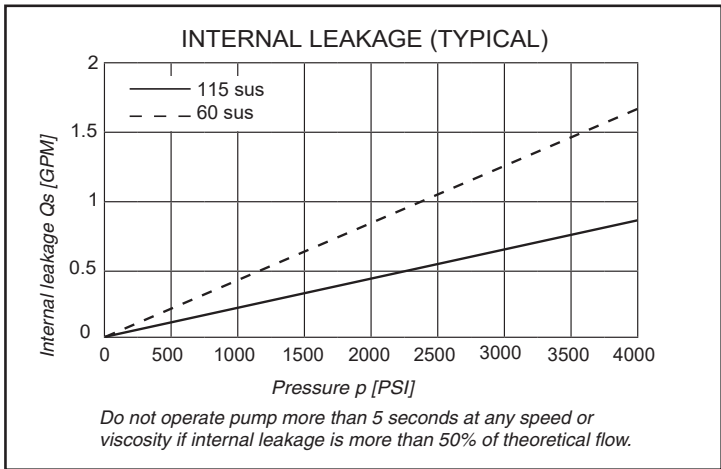

FRD-11

FORD

CHELSEA®

6R140 Gas F650/750; MY2013-2015

LEFT SIDE ONLY

TRANSMISSION GEAR DATA:

L.S. 06-BOLT Opening Gear FORWARD of Centerline
52 Teeth - SPUR

PITCH LINE TO APERTURE FACE:

3.4550" (87.7640MM)

CAUTION: Application Approval Required for PTO Output Shaft Speeds Above 2500 RPM

PTO Model	Torq	Dir Rot	Engine %		Filler Block	Adapter Assy	Stud Kit	PTO Model	Torq	Dir Rot	Engine %		Filler Block	Adapter Assy	Stud Kit
	I / C †		Fwd	Rev					I / C †		Fwd	Rev			
ONE SPEED - TWO GEAR - POWERSHIFT (HYDRAULIC)															

249GMLLX-*2 (1)	200 I	Opp	124				Furnished								
249GMLLX-*V (1)	200 I	Opp	124				Furnished								
272JCLLP-*8	300 I	Opp	61				Furnished								
272JDLLP-*8	300 I	Opp	74				Furnished								
272JGLLP-*8	300 I	Opp	87				Furnished								
272JKLLP-*8	300 I	Opp	98				Furnished								
272JMLLP-*8	274 I	Opp	109				Furnished								
272JPLLP-*8	246 I	Opp	122				Furnished								
272JSLLP-*8	220 I	Opp	137				Furnished								

See next page for more pump options.

Continued on Next Page

† I = Intermittent Torque Only - De-rate Torque Rating 30% for Continuous Duty.

C = Continuous or Intermittent Torque - No need to De-Rate Torque Rating.

IMPORTANT: Refer to the back of this transmission section and read all notes associated with this application page. Some notes may affect the proper PTO selection.

WARNING: If any Chelsea PTO is purchased without a Chelsea supplied activation switch, warning light, and warning light installation instructions, which are normally included with the PTO, it is the full responsibility of the installer to ensure the PTO is properly installed and electrically interfaced with the OE truck communication system. The installer assumes full responsibility for warning the operator of the truck that the PTO is engaged or disengaged. Failure to adequately warn the operator could result in death, personal injury, and/or property damage.

CAUTION: FORD PTO Driver Gear Torque ratings and HP vary by platform (F250-550 or F650/750), fuel type (Gas or Diesel), and operating

(1) Input Gear Part No. 5-P-1436

Ford

CHELSEA®

FORD

FRD-11

6R140 Gas F650/750; MY2013-2015

LEFT SIDE ONLY

TRANSMISSION GEAR DATA:

L.S. 06-BOLT Opening Gear FORWARD of Centerline
52 Teeth - SPUR

PITCH LINE TO APERTURE FACE:

3.4550" (87.7640MM)

Pump Option Charts

249 Series Gear Pump Options

Chelsea CGP-P11 Series Pump Specs for 4 x 2 and 4 x 4 Vehicles (3/4" - 11 Tooth Pump Spline – AD Output)

Order Code w/ PTO (C)	Chelsea Pump Model	Displacement in ³ /rev	GPM (A)	Pump (A) HP	Torque (A) lb-ft	Pressure PSI		Max Speed RPM		Max Pump Flow GPM
						Intermittent	Continuous	Pump	Engine (B)	
16	CGP-P11A016-5GC	0.37	2.15	4.5	16.0	3990	3625	4000	2016	3.6
26	CGP-P11A026-5GC	0.61	3.54	7.5	26.4	3990	3625	3600	2016	5.9
32	CGP-P11A032-5GC	0.73	4.23	9.0	31.6	3990	3625	3500	2016	7.1
37	CGP-P11A037-5GC	0.85	4.93	10.4	36.8	3990	3625	3300	2016	8.3
42	CGP-P11A042-5GC	0.98	5.68	12.0	42.4	3990	3625	3000	2016	9.5
55	CGP-P11A055-5GC	1.28	7.42	14.8	52.1	3480	3410	2800	2016	12.5
61	CGP-P11A061-5GE	1.40	8.12	15.5	54.6	3410	3265	2800	2016	13.6
71	CGP-P11A071-5GE	1.65	9.57	15.4	54.3	2900	2755	2400	1935	15.4
82	CGP-P11A082-5GE	1.89	10.96	15.3	54.0	2465	2395	2300	1855	16.9
87	CGP-P11A087-5GE	2.01	11.65	15.3	54.0	2320	2250	2000	1613	15.7

Chelsea PGP-315 Series Pump Specs for 4 x 2 Vehicles Only (3/4" - 11 Tooth Pump Spline – AD Output)

Order Code w/ PTO	Chelsea Pump Model	Displacement in ³ /rev	GPM (A)	Pump (A) HP	Torque (A) lb-ft	Pressure PSI		Max Speed RPM		Max Pump Flow GPM
						Intermittent	Continuous	Pump	Engine (B)	
08	CGP-P31B081-5AG	1.86	10.78	20.8	73.3	3300	3300	3000	2016	18.1
09	CGP-P31B094-5AG	2.17	12.58	21.3	75.1	2900	2900	3000	2016	21.1
11	CGP-P31B107-5AG	2.48	14.38	21.0	74.0	2500	2500	3000	2016	24.2

Chelsea P16 Series Pump Specs for 4 x 2 Vehicles Only (7/8" - 13 Tooth Pump Spline – XP Output)

Order Code w/ PTO	Chelsea Pump Model	Displacement in ³ /rev	GPM (A)	Pump (A) HP	Torque (A) lb-ft	Pressure PSI		Max Speed RPM		Max Pump Flow GPM
						Intermittent	Continuous	Pump	Engine (B)	
15	CGP16-150A-2D1	2.93	16.99	29.7	104.9	3000	3000	2800	2016	28.5

(A) GPM & Pump Input HP @ 1200 Engine RPM (1488 PTO Output RPM - 124% Ratio) & Continuous Pressure Rating with 90% efficiency rating considered.

(B) Max Engine Speed = (Max Pump Speed) / (1.24) for PTO Ratio Increase. Max Speed determined by Max PTO output speed of 2500.

(C) For Pump Codes 61, 71, 82 & 87 - 45 degree fittings are required to connect hydraulic hoses for clearance. Order Kit number 329667X

CAUTION: 249 Gear Pump Options: The PTO drive gear delivers up to 250 lb-ft torque to the aftermarket PTO, and can manage the heat of 60 HP continuously. Higher horsepower can be delivered, but for shorter durations depending on the amount of power required. Ref: Ford Body Builders Manual; TorqShift Automatic Transmission.

FORMULAS:

GPM = Cu. In. x .004329 = G/Rev x 1488 RPMs x .90 efficiency

HP = (GPM x Max PSI) / 1714

Torque = (HP x 5252) / 1488 RPMs

Ford

FRD-11

FORD

CHELSEA®

6R140 Gas F650/750; MY2013-2015

LEFT SIDE ONLY

TRANSMISSION GEAR DATA:

L.S. 06-BOLT Opening Gear FORWARD of Centerline
52 Teeth - SPUR

PITCH LINE TO APERTURE FACE:

3.4550" (87.7640MM)

Pump Option Charts

249 Series Vane Pump Options

Chelsea 249V Integral Vane Pump Data for 4 x 2 or 4 x 4 Vehicles

Option Code w/ PTO	Chelsea Pump Cartridge Number	Displacement in ³ /rev	GPM (D)	Pump (D) HP	Torque (D) lb-ft	Pressure PSI		Pump Speed RPM		Max Speed RPM Engine (B)
						Intermittent	Continuous	Min.	Max	
08	380418-08	1.61	9.33	19	67	4000	3500	400	2800	2015
10	380418-10	2.08	12.06	25	87	4000	3500	400	2800	2015
12	380418-12	2.26	13.10	27	94	4000	3500	400	2800	2015
14	380418-14	2.81	16.29	33	117	4000	3500	400	2800	2015
17	380418-17	3.56	20.64	42	149	4000	3500	400	2800	2015
20	380418-20	3.89	22.55	46	163	4000	3500	400	2800	2015
22	380418-22	4.29	24.87	51	179	4000	3500	400	2800	2015
25	380418-25	4.84	28.06	57	202	4000	3500	400	2800	2015
157	380418-157					4000	3500	400	2800	2015

(A) GPM & Pump Input HP @ 1200 Engine RPM (1488 PTO Output RPM - 124% Ratio) & Continuous Pressure Rating with 90% efficiency rating considered.

(B) Max Engine Speed = (Max Pump Speed) / (1.24) for PTO Ratio Increase. Max Speed determined by Max PTO output speed of 2500.

(D) GPM & Pump Input HP @ 1200 Engine RPM (1488 PTO Output RPM - 124% Ratio) & 2000 PSI Continuous Pressure Rating.

See leakage chart for additional flow losses at other pressures.

CAUTION: 249V Pump Options: The PTO drive gear delivers up to 250 lb-ft torque to the aftermarket PTO, and can manage the heat of 40 HP continuously. Higher horsepower can be delivered, but for shorter durations depending on the amount of power required. Ref: Ford Body Builders Manual; TorqShift Automatic Transmission.

NOTE: Refer to Chelsea Owner's Manual HY25-1FRD-M1/US for complete vane pump information.

FORMULAS:

GPM = Cu. In. x .004329 = G/Rev x 1488 RPMs x .90 efficiency

HP = (GPM x Max PSI) / 1714

Torque = (HP x 5252) / 1488 RPMs

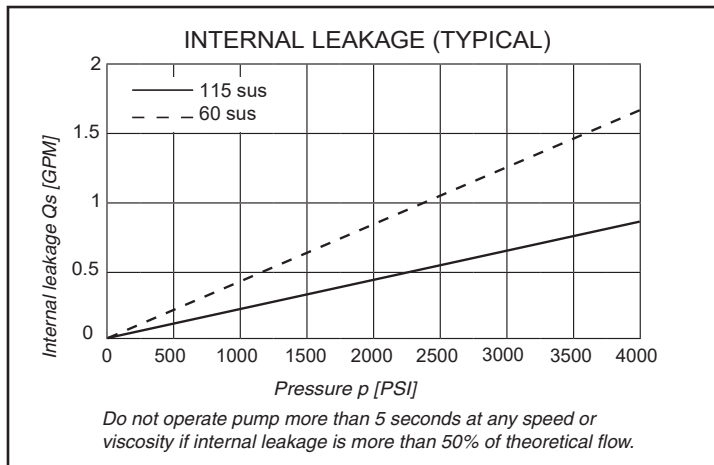

Ford

6R140 Gas F250-550; MY2017-MY2019
6R140 Gas F650/750; MY2016-Current

LEFT SIDE ONLY

TRANSMISSION GEAR DATA:
L.S. 06-BOLT Opening Gear FORWARD of Centerline
52 Teeth - SPUR
PITCH LINE TO APERTURE FACE:
3.4550" (87.7640MM)

CAUTION: Application Approval Required for PTO Output Shaft Speeds Above 2500 RPM

PTO Model	Torq	Dir Rot	Engine %		Filler Block	Adapter Assy	Stud Kit	PTO Model	Torq	Dir Rot	Engine %		Filler Block	Adapter Assy	Stud Kit
	I / C †		Fwd	Rev					I / C †		Fwd	Rev			

ONE SPEED - TWO GEAR - POWERSHIFT (HYDRAULIC)

249HMLLX-*2 (1)	200 I	Opp	124				Furnished
249HMLLX-*4 (1)	200 I	Opp	124				Furnished
249HMLLX-*V (1)	200 I	Opp	124				Furnished
272HCLLP-*8	300 I	Opp	61				Furnished
272HDLLP-*8	300 I	Opp	74				Furnished
272HGLLP-*8	300 I	Opp	87				Furnished
272HKLLP-*8	300 I	Opp	98				Furnished
272HMLLP-*8	274 I	Opp	109				Furnished
272HPLLP-*8	246 I	Opp	122				Furnished
272HSLLP-*8	220 I	Opp	137				Furnished

See next page for more pump options.

Continued on Next Page

† I = Intermittent Torque Only - De-rate Torque Rating 30% for Continuous Duty. C = Continuous or Intermittent Torque - No need to De-Rate Torque Rating.

IMPORTANT: Refer to the back of this transmission section and read all notes associated with this application page. Some notes may affect the proper PTO selection.

WARNING: If any Chelsea PTO is purchased without a Chelsea supplied activation switch, warning light, and warning light installation instructions, which are normally included with the PTO, it is the full responsibility of the installer to ensure the PTO is properly installed and electrically interfaced with the OE truck communication system. The installer assumes full responsibility for warning the operator of the truck that the PTO is engaged or disengaged. Failure to adequately warn the operator could result in death, personal injury, and/or property damage.

CAUTION: FORD PTO Driver Gear Torque ratings and HP vary by platform (F250-550 or F650/750), fuel type (Gas or Diesel), and operating

(1) Input Gear Part No. 5-P-1436



FRD-12

FORD

CHELSEA®

6R140 Gas F250-550; MY2017-MY2019
6R140 Gas F650/750; MY2016-Current

LEFT SIDE ONLY

TRANSMISSION GEAR DATA:

L.S. 06-BOLT Opening Gear FORWARD of Centerline
52 Teeth - SPUR

PITCH LINE TO APERTURE FACE:

3.4550" (87.7640MM)

Pump Option Charts

249 Series Gear Pump Options

Chelsea CGP-P11 Series Pump Specs for 4 x 2 and 4 x 4 Vehicles (3/4" - 11 Tooth Pump Spline - AD Output)

Order Code w/ PTO (C)	Chelsea Pump Model	Displacement in ³ /rev	GPM (A)	Pump (A) HP	Torque (A) lb-ft	Pressure PSI		Max Speed RPM		Max Pump Flow GPM
						Intermittent	Continuous	Pump	Engine (B)	
16	CGP-P11A016-5GC	0.37	2.15	4.5	16.0	3990	3625	4000	2016	3.6
26	CGP-P11A026-5GC	0.61	3.54	7.5	26.4	3990	3625	3600	2016	5.9
32	CGP-P11A032-5GC	0.73	4.23	9.0	31.6	3990	3625	3500	2016	7.1
37	CGP-P11A037-5GC	0.85	4.93	10.4	36.8	3990	3625	3300	2016	8.3
42	CGP-P11A042-5GC	0.98	5.68	12.0	42.4	3990	3625	3000	2016	9.5
55	CGP-P11A055-5GC	1.28	7.42	14.8	52.1	3480	3410	2800	2016	12.5
61	CGP-P11A061-5GE	1.40	8.12	15.5	54.6	3410	3265	2800	2016	13.6
71	CGP-P11A071-5GE	1.65	9.57	15.4	54.3	2900	2755	2400	1935	15.4
82	CGP-P11A082-5GE	1.89	10.96	15.3	54.0	2465	2395	2300	1855	16.9
87	CGP-P11A087-5GE	2.01	11.65	15.3	54.0	2320	2250	2000	1613	15.7

Chelsea PGP-315 Series Pump Specs for 4 x 2 Vehicles Only (3/4" - 11 Tooth Pump Spline - AD Output)

Order Code w/ PTO	Chelsea Pump Model	Displacement in ³ /rev	GPM (A)	Pump (A) HP	Torque (A) lb-ft	Pressure PSI		Max Speed RPM		Max Pump Flow GPM
						Intermittent	Continuous	Pump	Engine (B)	
08	CGP-P31B081-5AG	1.86	10.78	20.8	73.3	3300	3300	3000	2016	18.1
09	CGP-P31B094-5AG	2.17	12.58	21.3	75.1	2900	2900	3000	2016	21.1
11	CGP-P31B107-5AG	2.48	14.38	21.0	74.0	2500	2500	3000	2016	24.2

Chelsea P16 Series Pump Specs for 4 x 2 Vehicles Only (7/8" - 13 Tooth Pump Spline - XP Output)

Order Code w/ PTO	Chelsea Pump Model	Displacement in ³ /rev	GPM (A)	Pump (A) HP	Torque (A) lb-ft	Pressure PSI		Max Speed RPM		Max Pump Flow GPM
						Intermittent	Continuous	Pump	Engine (B)	
15	CGP16-150A-2D1	2.93	16.99	29.7	104.9	3000	3000	2800	2016	28.5

(A) GPM & Pump Input HP @ 1200 Engine RPM (1488 PTO Output RPM - 124% Ratio) & Continuous Pressure Rating with 90% efficiency rating considered.

(B) Max Engine Speed = (Max Pump Speed) / (1.24) for PTO Ratio Increase. Max Speed determined by Max PTO output speed of 2500.

(C) For Pump Codes 61, 71, 82 & 87 - 45 degree fittings are required to connect hydraulic hoses for clearance. Order Kit number 329667X

CAUTION: 249 Gear Pump Options: The PTO drive gear delivers up to 250 lb-ft torque to the aftermarket PTO, and can manage the heat of 60 HP continuously. Higher horsepower can be delivered, but for shorter durations depending on the amount of power required. Ref: Ford Body Builders Manual; TorqShift Automatic Transmission.

FORMULAS:

GPM = Cu. In. x .004329 = G/Rev x 1488 RPMs x .90 efficiency

HP = (GPM x Max PSI) / 1714

Torque = (HP x 5252) / 1488 RPMs

Ford

6R140 Gas F250-550; MY2017-MY2019
6R140 Gas F650/750; MY2016-Current

LEFT SIDE ONLY

TRANSMISSION GEAR DATA:
L.S. 06-BOLT Opening Gear FORWARD of Centerline
52 Teeth - SPUR
PITCH LINE TO APERTURE FACE:
3.4550" (87.7640MM)

Pump Option Charts

249 Series Vane Pump Options

Chelsea 249V Integral Vane Pump Data for 4 x 2 or 4 x 4 Vehicles

Option Code w/ PTO	Chelsea Pump Cartridge Number	Displacement in ³ /rev	GPM (D)	Pump (D) HP	Torque (D) lb-ft	Pressure PSI		Pump Speed RPM		Max Speed RPM Engine (B)
						Intermittent	Continuous	Min.	Max	
08	380418-08	1.61	9.33	19	67	4000	3500	400	2800	2015
10	380418-10	2.08	12.06	25	87	4000	3500	400	2800	2015
12	380418-12	2.26	13.10	27	94	4000	3500	400	2800	2015
14	380418-14	2.81	16.29	33	117	4000	3500	400	2800	2015
17	380418-17	3.56	20.64	42	149	4000	3500	400	2800	2015
20	380418-20	3.89	22.55	46	163	4000	3500	400	2800	2015
22	380418-22	4.29	24.87	51	179	4000	3500	400	2800	2015
25	380418-25	4.84	28.06	57	202	4000	3500	400	2800	2015
157	380418-157					4000	3500	400	2800	2015

(A) GPM & Pump Input HP @ 1200 Engine RPM (1488 PTO Output RPM - 124% Ratio) & Continuous Pressure Rating with 90% efficiency rating considered.

(B) Max Engine Speed = (Max Pump Speed) / (1.24) for PTO Ratio Increase. Max Speed determined by Max PTO output speed of 2500.

(D) GPM & Pump Input HP @ 1200 Engine RPM (1488 PTO Output RPM - 124% Ratio) & 2000 PSI Continuous Pressure Rating.

See leakage chart for additional flow losses at other pressures.

CAUTION: 249V Pump Options: The PTO drive gear delivers up to 250 lb-ft torque to the aftermarket PTO, and can manage the heat of 40 HP continuously. Higher horsepower can be delivered, but for shorter durations depending on the amount of power required. Ref: Ford Body Builders Manual; TorqShift Automatic Transmission.

NOTE: Refer to Chelsea Owner's Manual HY25-1FRD-M1/US for complete vane pump information.

FORMULAS:

GPM = Cu. In. x .004329 = G/Rev x 1488 RPMs x .90 efficiency

HP = (GPM x Max PSI) / 1714

Torque = (HP x 5252) / 1488 RPMs

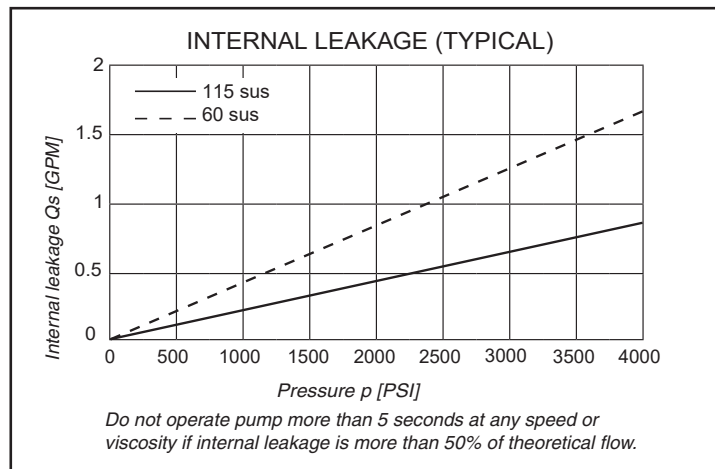

FRD-13

FORD

CHELSEA®

10R140 Diesel F250-600; MY2020-Current

LEFT SIDE ONLY**TRANSMISSION GEAR DATA:**L.S. 10-BOLT Opening Gear FORWARD of Centerline
46 Teeth - SPUR**PITCH LINE TO APERTURE FACE:**

1.75" (44.45MM)

CAUTION: Application Approval Required for PTO Output Shaft Speeds Above 2500 RPM

PTO Model	Torq	Dir Rot	Engine %		Filler Block	Adapter Assy	Stud Kit	PTO Model	Torq	Dir Rot	Engine %		Filler Block	Adapter Assy	Stud Kit
	I / C †		Fwd	Rev					I / C †		Fwd	Rev			

ONE SPEED - TWO GEAR - POWERSHIFT (HYDRAULIC)

210FMMFP-*2 (1)	235 I	Opp	144				Furnished
210FMMFP-*4 (1)	235 I	Opp	144				Furnished

See next page for more pump options.

Continued on Next Page

† I = Intermittent Torque Only - De-rate Torque Rating 30% for Continuous Duty.

C = Continuous or Intermittent Torque - No need to De-Rate Torque Rating.

IMPORTANT: Refer to the back of this transmission section and read all notes associated with this application page. Some notes may affect the proper PTO selection.**WARNING:** If any Chelsea PTO is purchased without a Chelsea supplied activation switch, warning light, and warning light installation instructions, which are normally included with the PTO, it is the full responsibility of the installer to ensure the PTO is properly installed and electrically interfaced with the OE truck communication system. The installer assumes full responsibility for warning the operator of the truck that the PTO is engaged or disengaged. Failure to adequately warn the operator could result in death, personal injury, and/or property damage.**CAUTION:** The applications on this page are rated for a diesel engine in stationary mode (based on 300 lbs-ft at transmission PTO gear).

(1) Input Gear Part No. 5-P-1597

10R140 Diesel F250-600; MY2020-Current

LEFT SIDE ONLY

TRANSMISSION GEAR DATA:

L.S. 10-BOLT Opening Gear FORWARD of Centerline
46 Teeth - SPUR

PITCH LINE TO APERTURE FACE:

1.75" (44.45MM)

Pump Option Charts

210 Series Gear Pump Options

Chelsea CGP-P11 Series Pump Specs for 4 x 2 and 4 x 4 Vehicles (3/4" - 11 Tooth Pump Spline – AD Output)

Order Code w/ PTO (C)	Chelsea Pump Model	Displacement in ³ /rev	GPM (A)	Pump (A) HP	Torque (A) lb-ft	Pressure PSI		Max Speed RPM		Max Pump Flow GPM	Rear Pump Ports	
						Intermittent	Continuous	Pump	Engine (B)		Inlet	Outlet
21	CGP-P11A021-5AC	0.49	3.30	7.0	24.6	3988	3625	4000	1728	4.8	SAE 12	SAE 10
26	CGP-P11A026-5AC	0.61	4.11	8.7	30.7	3988	3625	3600	1728	5.9	SAE 12	SAE 10
32	CGP-P11A032-5AC	0.73	4.91	10.4	36.7	3988	3625	3500	1728	7.1	SAE 12	SAE 10
37	CGP-P11A037-5AC	0.85	5.72	12.1	42.7	3988	3625	3300	1728	8.3	SAE 12	SAE 10
42	CGP-P11A042-5AC	0.98	6.60	14.0	49.3	3988	3625	3000	1728	9.5	SAE 12	SAE 10
50	CGP-P11A050-5AC	1.16	7.81	16.5	58.3	3770	3625	3000	1728	11.3	SAE 12	SAE 10
55	CGP-P11A055-5AP	1.28	8.62	17.1	60.5	3480	3410	2800	1728	12.5	SAE 16	SAE 12
61	CGP-P11A061-5AP	1.40	9.43	18.0	63.4	3408	3265	2800	1728	13.6	SAE 16	SAE 12
71	CGP-P11A071-5AP	1.65	11.11	17.9	63.0	2900	2755	2300	1597	14.8	SAE 16	SAE 12
82	CGP-P11A082-5AP	1.89	12.72	17.8	62.8	2465	2395	2300	1597	16.9	SAE 16	SAE 12
87	CGP-P11A087-5AP	2.01	13.53	17.8	62.7	2320	2250	2000	1389	15.7	SAE 16	SAE 12

Chelsea PGP-315 Series Pump Specs for 4 x 2 and 4 x 4 Vehicles (3/4" - 11 Tooth Pump Spline – AD Output)

Order Code w/ PTO	Chelsea Pump Model	Displacement in ³ /rev	GPM (A)	Pump (A) HP	Torque (A) lb-ft	Pressure PSI		Max Speed RPM		Max Pump Flow GPM	Rear Pump Ports	
						Intermittent	Continuous	Pump	Engine (B)		Inlet	Outlet
8	CGP-P31B081-5AG	1.86	12.52	24.1	85.1	3300	3300	3000	1728	18.1	SAE 16	SAE 16
9	CGP-P31B094-5AG	2.17	14.61	24.7	87.2	2900	2900	3000	1728	21.1	SAE 16	SAE 16
11	CGP-P31B107-5AG	2.48	16.70	24.4	86.0	2500	2500	3000	1728	24.2	SAE 16	SAE 16

Chelsea P16 Series Pump Specs for 4 x 2 and 4 x 4 Vehicles (7/8" - 13 Tooth Pump Spline – XP Output)

Order Code w/ PTO	Chelsea Pump Model	Displacement in ³ /rev	GPM (A)	Pump (A) HP	Torque (A) lb-ft	Pressure PSI		Max Speed RPM		Max Pump Flow GPM	Rear Pump Ports	
						Intermittent	Continuous	Pump	Engine (B)		Inlet	Outlet
15	CGP16-150A-2D1	2.93	19.73	34.5	121.9	3000	3000	2800	1728	28.5	SAE 20	SAE 16
18	CGP16-180A-2D1	3.51	23.63	30.3	107.1	2200	2200	2500	1728	34.2	SAE 20	SAE 16
20	CGP16-200A-2D1	3.90	26.26	30.6	108.1	2000	2000	2200	1528	33.4	SAE 20	SAE 16

(A) GPM & Pump Input HP @ 1200 Engine RPM (1728 PTO Output RPM - 144% Ratio) & Continuous Pressure Rating with 90% efficiency rating considered.
(B) Max Engine Speed = Minimum of (1) (Max Pump Speed) / 1.44 PTO Ratio and (2) 2500 RPM maximum PTO output speed. PTO output speeds above 2500 RPM requires application approval from Parker Chelsea.

NOTE: Minimum ideal engine speed for Ford Super Duty in stationary mode is 900 RPM (Diesel) and 700 RPM (Gas). Consult fordbbas.com

NOTE: Ford's 10R140 transmission delivers up to 300 lb-ft to PTO. Consult fordbbas.com for power and torque limitations based on vehicle configuration.

FORMULAS:

GPM = Cu. In. x .004329 = G/Rev x 1728 RPMs x .90 efficiency

HP = (GPM x Max PSI) / 1714

Torque = (HP x 5252) / 1728 RPMs

FRD-14

FORD

CHELSEA®

10R140 Gas F250-600; MY2020-Current

LEFT SIDE ONLY

TRANSMISSION GEAR DATA:

L.S. 10-BOLT Opening Gear FORWARD of Centerline
46 Teeth - SPUR

PITCH LINE TO APERTURE FACE:

1.75" (44.45MM)

CAUTION: Application Approval Required for PTO Output Shaft Speeds Above 2500 RPM

PTO Model	Torq	Dir Rot	Engine %		Filler Block	Adapter Assy	Stud Kit	PTO Model	Torq	Dir Rot	Engine %		Filler Block	Adapter Assy	Stud Kit
	I / C †		Fwd	Rev					I / C †		Fwd	Rev			

ONE SPEED - TWO GEAR - POWERSHIFT (HYDRAULIC)

210GMMFP-*2 (1)	235 I	Opp	144				Furnished
210GMMFP-*4 (1)	235 I	Opp	144				Furnished

Continued on Next Page

† I = Intermittent Torque Only - De-rate Torque Rating 30% for Continuous Duty.

C = Continuous or Intermittent Torque - No need to De-Rate Torque Rating.

IMPORTANT: Refer to the back of this transmission section and read all notes associated with this application page. Some notes may affect the proper PTO selection.

WARNING: If any Chelsea PTO is purchased without a Chelsea supplied activation switch, warning light, and warning light installation instructions, which are normally included with the PTO, it is the full responsibility of the installer to ensure the PTO is properly installed and electrically interfaced with the OE truck communication system. The installer assumes full responsibility for warning the operator of the truck that the PTO is engaged or disengaged. Failure to adequately warn the operator could result in death, personal injury, and/or property damage.

CAUTION: The applications on this page are rated for a diesel engine in stationary mode (based on 300 lbs-ft at transmission PTO gear).

(1) Input Gear Part No. 5-P-1597

Ford

CHELSEA®

FORD

FRD-14

10R140 Gas F250-600; MY2020-Current

LEFT SIDE ONLY

TRANSMISSION GEAR DATA:

L.S. 10-BOLT Opening Gear FORWARD of Centerline
46 Teeth - SPUR

PITCH LINE TO APERTURE FACE:

1.75" (44.45MM)

Pump Option Charts

210 Series Gear Pump Options

Chelsea CGP-P11 Series Pump Specs for 4 x 2 and 4 x 4 Vehicles (3/4" - 11 Tooth Pump Spline – AD Output)

Order Code w/ PTO (C)	Chelsea Pump Model	Displacement in ³ /rev	GPM (A)	Pump (A) HP	Torque (A) lb-ft	Pressure PSI		Max Speed RPM		Max Pump Flow GPM	Rear Pump Ports	
						Intermittent	Continuous	Pump	Engine (B)		Inlet	Outlet
21	CGP-P11A021-5AC	0.49	3.30	7.0	24.6	3988	3625	4000	1728	4.8	SAE 12	SAE 10
26	CGP-P11A026-5AC	0.61	4.11	8.7	30.7	3988	3625	3600	1728	5.9	SAE 12	SAE 10
32	CGP-P11A032-5AC	0.73	4.91	10.4	36.7	3988	3625	3500	1728	7.1	SAE 12	SAE 10
37	CGP-P11A037-5AC	0.85	5.72	12.1	42.7	3988	3625	3300	1728	8.3	SAE 12	SAE 10
42	CGP-P11A042-5AC	0.98	6.60	14.0	49.3	3988	3625	3000	1728	9.5	SAE 12	SAE 10
50	CGP-P11A050-5AC	1.16	7.81	16.5	58.3	3770	3625	3000	1728	11.3	SAE 12	SAE 10
55	CGP-P11A055-5AP	1.28	8.62	17.1	60.5	3480	3410	2800	1728	12.5	SAE 16	SAE 12
61	CGP-P11A061-5AP	1.40	9.43	18.0	63.4	3408	3265	2800	1728	13.6	SAE 16	SAE 12
71	CGP-P11A071-5AP	1.65	11.11	17.9	63.0	2900	2755	2300	1597	14.8	SAE 16	SAE 12
82	CGP-P11A082-5AP	1.89	12.72	17.8	62.8	2465	2395	2300	1597	16.9	SAE 16	SAE 12
87	CGP-P11A087-5AP	2.01	13.53	17.8	62.7	2320	2250	2000	1389	15.7	SAE 16	SAE 12

Chelsea PGP-315 Series Pump Specs for 4 x 2 and 4 x 4 Vehicles (3/4" - 11 Tooth Pump Spline – AD Output)

Order Code w/ PTO	Chelsea Pump Model	Displacement in ³ /rev	GPM (A)	Pump (A) HP	Torque (A) lb-ft	Pressure PSI		Max Speed RPM		Max Pump Flow GPM	Rear Pump Ports	
						Intermittent	Continuous	Pump	Engine (B)		Inlet	Outlet
8	CGP-P31B081-5AG	1.86	12.52	24.1	85.1	3300	3300	3000	1728	18.1	SAE 16	SAE 16
9	CGP-P31B094-5AG	2.17	14.61	24.7	87.2	2900	2900	3000	1728	21.1	SAE 16	SAE 16
11	CGP-P31B107-5AG	2.48	16.70	24.4	86.0	2500	2500	3000	1728	24.2	SAE 16	SAE 16

Chelsea P16 Series Pump Specs for 4 x 2 and 4 x 4 Vehicles (7/8" - 13 Tooth Pump Spline – XP Output)

Order Code w/ PTO	Chelsea Pump Model	Displacement in ³ /rev	GPM (A)	Pump (A) HP	Torque (A) lb-ft	Pressure PSI		Max Speed RPM		Max Pump Flow GPM	Rear Pump Ports	
						Intermittent	Continuous	Pump	Engine (B)		Inlet	Outlet
15	CGP16-150A-2D1	2.93	19.73	34.5	121.9	3000	3000	2800	1728	28.5	SAE 20	SAE 16
18	CGP16-180A-2D1	3.51	23.63	30.3	107.1	2200	2200	2500	1728	34.2	SAE 20	SAE 16
20	CGP16-200A-2D1	3.90	26.26	30.6	108.1	2000	2000	2200	1528	33.4	SAE 20	SAE 16

(A) GPM & Pump Input HP @ 1200 Engine RPM (1728 PTO Output RPM - 144% Ratio) & Continuous Pressure Rating with 90% efficiency rating considered.
 (B) Max Engine Speed = Minimum of (1) (Max Pump Speed) / 1.44 PTO Ratio and (2) 2500 RPM maximum PTO output speed. PTO output speeds above 2500 RPM requires application approval from Parker Chelsea.

NOTE: Minimum ideal engine speed for Ford Super Duty in stationary mode is 900 RPM (Diesel) and 700 RPM (Gas). Consult fordbbas.com

NOTE: Ford's 10R140 transmission delivers up to 300 lb-ft to PTO. Consult fordbbas.com for power and torque limitations based on vehicle configuration.

FORMULAS:

GPM = Cu. In. x .004329 = G/Rev x 1728 RPMs x .90 efficiency

HP = (GPM x Max PSI) / 1714

Torque = (HP x 5252) / 1728 RPMs

Ford

Ford Notes

FRD-9

1. Standard Parker PGP-P17 pumps may interfere with the transmission shift lever, order Chelsea FGP-P17 Series pumps to assure shifter clearance.
2. The PTO mounting gasket (22-P-120) is supplied with the PTO. It is the correct thickness and material so that the customer does not have to set backlash. DO NOT use gasket supplied with the transmission under the 6-Bolt cover plate.
3. 247FMKSP-*2 -- 4 x 2 applications: all output options and all pumps listed in the pump chart are available.
4. 247FMKSP-*4 -- 4 x 4 applications will only work with a modified PGP-P11 (CGP-P11) pump. Use one of the following output option codes when ordering: 16, 26, 37, 42, 55, 61, 71, 82, 86 (See Pump Chart).
5. Ford provides an option for the use of one of the "Upfitter" Switches to be used as a PTO switch. Chelsea does not recommend the use of the UNPROTECTED switch for PTO function, but if required, contact Chelsea Technical Services for assistance (662-895-1052).
6. The 272-FORD does not have noise dampening technology incorporated into the PTO like the 249 Series. Therefore, a gear clatter noise will be present during idle with no load on the PTO.

FRD-10

1. Mobile and Stationary Mode Operations are supported. The maximum load (Torque) allowable for Mobile Mode is 150 lbs-ft at the transmission PTO driver gear. If the PTO feature is used for extended periods of time without vehicle movement it is recommended to switch to Stationary Mode. In Stationary Mode maximum load (Torque) is 250 lb-ft at the transmission PTO driver gear.
2. Ford provides an option for the use of one of the "Upfitter" Switches to be used as a PTO switch. Chelsea does not recommend the use of the UNPROTECTED switch for PTO function, but if required, contact Chelsea Technical Services for assistance (662-895-1052).
3. 249FMLLX-*2 -- 4 x 2 applications, all output options and all gear pumps listed in the pump chart are available.
4. 249FMLLX-*4 -- 4 x 4 applications only and will come with a modified PGP-P11 (CGP-P11) gear pump with the PTO from the factory when one of the following output option codes is ordered; 16, 26, 32, 37, 42, 55, 61, 71, 82, 87 (See Pump Chart). Or one of the following output shafts XD, XP or AD.
5. For Pump Codes 61, 71, 82 & 87 - 45 degree fittings are required to connect hydraulic hoses for clearance. Order Kit number 329667X in addition to the PTO.
6. 249FMLLX-*V-- Both 4 x 2 and 4 x 4 applications. 249 Series with integral vane pump options (See Pump Chart).
7. The 272-FORD does not have noise dampening technology incorporated into the PTO like the 249 Series. Therefore, a gear clatter noise will be present during idle with no load on the PTO.

FRD-11

1. Only Stationary Mode Operations are supported for this application page. The Maximum Load (Torque) in Stationary Mode is 250 lbs-ft at the transmission PTO driver gear and 200 lbs-ft at the PTO output.
2. Ford Does Not Recommend PTO Operation At or Below 900 RPM for the 6.8L Gas Engine. Minimum Engine Speed 910 RPM and Maximum 2400 RPM. Reference Ford Bulletin Q-215 for Latest Information.
3. For MY2013 Ford F-650 4 x 2 w/Gas engine will come with a 6R140 transmission. This will require a heat shield (329931X) to protect the PTO from the exhaust. It is included with the PTO when ordering the 249 G mounting option.
4. 249GMLLX-*2 - 4 x 2 applications, all output options and all pumps listed in the pump chart are available.
5. Ford provides an option for the use of one of the "Upfitter" Switches to be used as a PTO switch. Chelsea does not recommend the use of the UNPROTECTED switch for PTO function, but if required, contact Chelsea Technical Services for assistance (662-895-1052).
6. For Pump Codes 61, 71, 82 & 87 - 45 degree fittings are required to connect hydraulic hoses for clearance. Order Kit number 329667X in addition to the PTO.
7. PTO Pressure Switch - if the PTO pressure switch needs to be re-indexed due to interference, use P/N 380451 90 degree fitting.

FRD-12

1. MY2016 F650/750 is only operable in Stationary Mode. Mobile Mode is supported for 2017 F250-750 and the Torque to the Transmission gear is reduced to 125 lb-ft and 100 lb-ft to the PTO output.
2. 249HMLLX-*2 -- 4 x 2 applications, all output options and all gear pumps listed in the pump chart are available.
3. Ford Does Not Recommend PTO Operation At or Below 900 RPM for the 6.8L Gas Engine. Minimum Engine Speed 910 RPM and Maximum 2400 RPM. Reference Ford Bulletin Q-215 for Latest Information.
4. FORD Gas applications require a Heat Shield Kit (329931X) that will be provided with the PTO to protect the PTO and its related components from the extreme temperatures near the exhaust pipes.
5. Ford provides Upfitter Switches that can be used as a PTO switch. Chelsea only recommends the use of protected circuits for PTO operations. Ensure the switch is protected by a fuse before use.
6. For Pump Codes 61, 71, 82 & 87 - 45 degree fittings are required to connect hydraulic hoses for clearance. Order Kit number 329667X in addition to the PTO.
7. PTO Pressure Switch - if the PTO pressure switch needs to be re-indexed due to interference, use P/N 380451 90 degree fitting.

Ford Notes

FRD-13

1. Mobile and Stationary Mode Operations are supported and vary based on vehicle configuration. If the PTO feature is used for extended periods of time without vehicle movement it is recommended to switch to Stationary Mode. For 6.7L Diesel, maximum load (torque) at the transmission gear is 150 lb-ft in mobile mode and 300 lb-ft in stationary. Consult FORD BBAS for the most up to date ratings.
2. All 4x4 compatible pumps MUST be mounted with the bulge toward the transmission.
3. The following output options are 4 x 2 only: SD Smart Start driveshaft, 18 gear pump and 20 gear pump.

FRD-14

1. Mobile and Stationary Mode Operations are supported and vary based on vehicle configuration. If the PTO feature is used for extended periods of time without vehicle movement it is recommended to switch to Stationary Mode. For 7.3L Gas, maximum load (torque) at the transmission gear is 125 lb-ft in mobile mode and 250 lb-ft in stationary. For 6.2L Gas, maximum load (torque) at the transmission gear is 115 lbs-ft in mobile mode and 250 lb-ft in stationary. Consult FORD BBAS for the most up to date ratings.
2. All 4x4 compatible pumps MUST be mounted with the bulge toward the transmission.
3. The following output options are 4 x 2 only: SD Smart Start driveshaft, 18 gear pump and 20 gear pump.
4. Thermal sleeving is required for lube hose and pressure switch on Gas applications. See owners manual for details.



GM

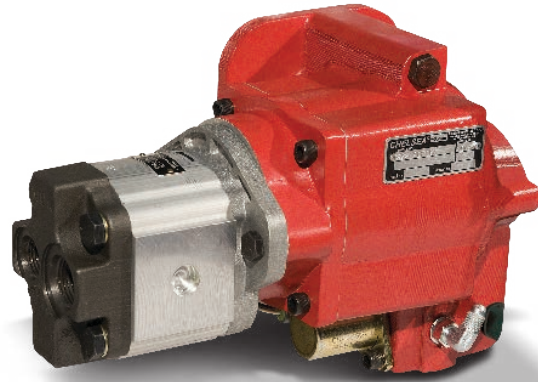
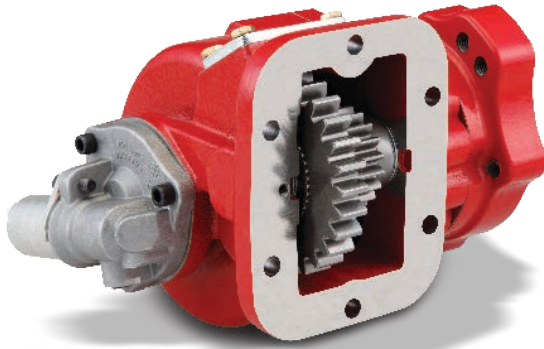

Parker | Chelsea

ENGINEERING **YOUR** SUCCESS.



WARNING — User Responsibility

FAILURE OR IMPROPER SELECTION OR IMPROPER USE OF THE PRODUCTS DESCRIBED HEREIN OR RELATED ITEMS CAN CAUSE DEATH, PERSONAL INJURY AND PROPERTY DAMAGE.

This document and other information from Parker Hannifin Corporation, its subsidiaries and authorized distributors provide product or system options for further investigation by users having technical expertise.

The user, through its own analysis and testing, is solely responsible for making the final selection of the system and components and assuring that all performance, endurance, maintenance, safety and warning requirements of the application are met. The user must analyze all aspects of the application, follow applicable industry standards, and follow the information concerning the product in the current product catalog and in any other materials provided from Parker or its subsidiaries or authorized distributors.

To the extent that Parker or its subsidiaries or authorized distributors provide component or system options based upon data or specifications provided by the user, the user is responsible for determining that such data and specifications are suitable and sufficient for all applications and reasonably foreseeable uses of the components or systems.

Offer of Sale

The items described in this document are hereby offered for sale by Parker Hannifin Corporation, its subsidiaries or its authorized distributors. This offer and its acceptance are governed by the provisions stated in the "Offer of Sale".



WARNING: This product can expose you to chemicals including Lead and Lead Compounds, and Di(2-ethylhexyl)phthalate (DEHP) which are known to the State of California to cause cancer and birth defects or other reproductive harm. For more information go to www.P65Warnings.ca.gov

© Copyright 2022, Parker Hannifin Corporation, All Rights Reserved

Transmission Make and Model	PTO Appl. Number	Number Forward Speeds	Teeth in PTO Driver
GM 3600 Cab-Chassis	ALL-17	5	R64
CH-465 (Code MM4 1968 to 1990)	CHV-2	4	L36-R36
GM-20	CHV-2	4	L36-R36
M-20	CHV-2	4	L36-R36
SM-465 (GMC) (Code MM4 1968 to 1990)	CHV-2	4	L36-R36
A465 (Low Cab Forward)	AIS-2	6	L69



IMPORTANT: See Safety Information in Section 1 of the Chelsea Applications catalog HY25-3000/US

Transmission PTO Driver & Apertures (Viewed from Rear of Transmission)
L-Left Side R-Right Side B-Bottom Side T-Top Side CS-Countershaft
For transmissions not listed, contact your authorized Chelsea Distributor.

ALL-17

GM

CHELSEA®

1000 (GM 3600 Cab-Chassis)

RIGHT SIDE ONLY

TRANSMISSION GEAR DATA:

R.S. 06-BOLT Opening Gear FORWARD of Centerline
64 Teeth - SPUR

PITCH LINE TO APERTURE FACE:

1.0080" (25.6032MM)

CAUTION: Application Approval Required for PTO Output Shaft Speeds Above 2500 RPM

PTO Model	Torq	Dir Rot	Engine %		Filler Block	Adapter Assy	Stud Kit	PTO Model	Torq	Dir Rot	Engine %		Filler Block	Adapter Assy	Stud Kit
	I / C †		Fwd	Rev					I / C †		Fwd	Rev			

ONE SPEED - TWO GEAR - POWERSHIFT (HYDRAULIC)

252GDHVX-*5 (1)	120 I	Eng	122	Furnished
252GMHVX-*5 (2)	50 I	Eng	178	Furnished

252 Pumps offered in the PGP511 with 5/8" - 9T / SAE A Flange

Option Order Code	Chelsea Pump Model	Displacement in ³ /rev	Displacement Gal/rev	Max Pressure PSI	Max Speed RPM	Shaft Size
1121	CGP-P11C021-1AC	0.49	0.002	3988	4000	5/8" - 9T
1126	CGP-P11C026-1AC	0.61	0.003	3988	3600	5/8" - 9T
1129	CGP-P11C029-1AC	0.67	0.003	3988	3600	5/8" - 9T
1137	CGP-P11C037-1AC	0.85	0.004	3988	3300	5/8" - 9T
1449	CGP-P31C054-1AE	1.24	0.005	3500	3000	5/8" - 9T
1462	CGP-P31C061-1AE	1.40	0.006	3500	3000	5/8" - 9T

252 Pumps offered in the PGP511 with 3/4" - 11T / SAE A Flange

Option Order Code	Chelsea Pump Model	Displacement in ³ /rev	Displacement Gal/rev	Max Pressure PSI	Max Speed RPM	Shaft Size
P37	CGP-P11C037-5AC	0.85	0.004	3988	3300	3/4" - 11T
P42	CGP-P11C042-5AC	0.98	0.004	3988	3000	3/4" - 11T
P71	CGP-P11C071-5AC	1.65	0.007	2900	2400	3/4" - 11T

† I = Intermittent Torque Only - De-rate Torque Rating 30% for Continuous Duty.

C = Continuous or Intermittent Torque - No need to De-Rate Torque Rating.

IMPORTANT: Refer to the back of this transmission section and read all notes associated with this application page. Some notes may affect the proper PTO selection.

CAUTION: The "PTO Enable" circuit signals the Transmission Control Module (TCM) to maintain line pressure to the PTO. Failure to provide this signal will activate the Variable Modulated Main Pressure and line pressure may not be sufficient to the PTO. This may cause damage to the PTO and /or Transmission.

(1) Input Gear Part No. 5-P-1294
(2) Input Gear Part No. 5-P-1386

GM

CHELSEA®

GM

CHV-2

CH-465 (Code MM4 1968 to 1990)
GM-20
M-20
SM-465 (GMC) (Code MM4 1968 to 1990)

LEFT SIDE ONLY

RIGHT SIDE ONLY

TRANSMISSION GEAR DATA:

L.S. 06-BOLT Opening Gear REAR of Centerline
36 Teeth - R.H. HELIX

PITCH LINE TO APERTURE FACE:
1.0850" (27.5600MM)

TRANSMISSION GEAR DATA:

R.S. 06-BOLT Opening Gear REAR of Centerline
36 Teeth - R.H. HELIX

PITCH LINE TO APERTURE FACE:
1.0850" (27.5600MM)

CAUTION: Application Approval Required for PTO Output Shaft Speeds Above 2500 RPM

PTO Model	Torq I / C †	Dir Rot	Engine %		Filler Block	Adapter Assy	Stud Kit	PTO Model	Torq I / C †	Dir Rot	Engine %		Filler Block	Adapter Assy	Stud Kit
			Fwd	Rev							Fwd	Rev			
ONE SPEED - TWO GEAR - MECHANICAL SHIFT															
442KFBQX-*6 (2)	250 I	Opp	35				7170-89X	442KFBQX-*4 (2)	250 I	Opp	35				7170-89X
442KLBQX-*6 (1)	250 I	Opp	45				7170-89X	442KLBQX-*4 (1)	250 I	Opp	45				7170-89X
442KQBQX-*6 (1)	225 I	Opp	48				7170-89X	442KQBQX-*4 (1)	225 I	Opp	48				7170-89X
442KRBQX-*6 (1)	225 I	Opp	56				7170-89X	442KRBQX-*4 (1)	225 I	Opp	56				7170-89X
442KSBQX-*6 (1)	200 I	Opp	67				7170-89X	442KSBQX-*4 (1)	200 I	Opp	67				7170-89X
442KUBQX-*6 (1)	195 I	Opp	80				7170-89X	442KUBQX-*4 (1)	195 I	Opp	80				7170-89X
442KWBQX-*6 (1)	175 I	Opp	94				7170-89X	442KWBQX-*4 (1)	175 I	Opp	94				7170-89X
442KXBQX-*6 (1)	140 I	Opp	111				7170-89X	442KXBQX-*4 (1)	140 I	Opp	111				7170-89X
ONE SPEED - FORWARD & REVERSE															
340XFBQX-*4 (3)	200 I	Opp	32	33	7-A-140(4)		328170-76X	340XFBQX-*4 (3)	200 I	Opp	32	33	7-A-140(4)		328170-76X
GEARED ADAPTERS															
626KBQX-3BP	250 I	Eng					7170-89X	626KBQX-4BP	250 I	Eng					7170-89X
630KBQX-3BP	250 I	Eng					7170-89X	630KBQX-4BP	250 I	Eng					7170-89X
645KBQX-3BP	250 I	Eng					7170-89X	645KBQX-4BP	250 I	Eng					7170-89X

† I = Intermittent Torque Only - De-rate Torque Rating 30% for Continuous Duty.

C = Continuous or Intermittent Torque - No need to De-Rate Torque Rating.

IMPORTANT: Refer to the back of this transmission section and read all notes associated with this application page. Some notes may affect the proper PTO selection.

- (1) Input Gear Part No. 5-P-1023
- (2) Input Gear Part No. 5-P-1084
- (3) Input Gear Part No. 5-P-720
- (4) Filler block furnished with PTO

AIS-2

GM

CHELSEA®

A465 (Isuzu Number for MY600)
MO36A6 (Mitsubishi/Fuso Number for MY600)
MY600

LEFT SIDE ONLY

TRANSMISSION GEAR DATA:

L.S. 06-BOLT Opening Gear FORWARD of Centerline
69 Teeth - SPUR

PITCH LINE TO APERTURE FACE:

1.0880" (27.6352MM)

CAUTION: Application Approval Required for PTO Output Shaft Speeds Above 2500 RPM

PTO Model	Torq	Dir Rot	Engine %		Filler Block	Adapter Assy	Stud Kit	PTO Model	Torq	Dir Rot	Engine %		Filler Block	Adapter Assy	Stud Kit
	I / C †		Fwd	Rev					I / C †		Fwd	Rev			

ONE SPEED - TWO GEAR POWERSHIFT (AIR OR HYDRAULIC)

272AAKUP-*5 (1)	158 C	Eng	69				Furnished
272ABKUP-*5 (2)	129 C	Eng	84				Furnished
272ACKUP-*5 (3)	106 C	Eng	102				Furnished
272ADKUP-*5 (4)	89 C	Eng	122				Furnished

† I = Intermittent Torque Only - De-rate Torque Rating 30% for Continuous Duty.

C = Continuous or Intermittent Torque - No need to De-Rate Torque Rating.

IMPORTANT: Refer to the back of this transmission section and read all notes associated with this application page. Some notes may affect the proper PTO selection.

- (1) Input Gear Part No. 5-P-1515-1X
- (2) Input Gear Part No. 5-P-1515-2X
- (3) Input Gear Part No. 5-P-1515-3X
- (4) Input Gear Part No. 5-P-1515-4X

GM Notes

ALL-17

1. For MY2015 GM has changed the engine exhaust design. The exhaust pipe can not be removed as in previous model years. This is causing issues with PTO installation. Contact GM Upfitter Integration for assistance on PTO installation.
2. There is torque converter lock up feature available with the 1000 series transmission. The torque converter lock up feature comes on and is controlled by the Transmission Control Module (TCM) at 1100 RPM transmission turbine speed when a signal is provided to the "PTO Enable" circuit of the TCM by the PTO switch. This equates to 1200-1250 RPM or higher engine speed, depending on PTO load. Lock up will only come on in the "PARK" position. The lock up clutch does not come on automatically in "DRIVE" at 1100 RPM. Refer to the appropriate owner's manual for wiring installation.
3. The PTO torque ratings shown are based on the maximum allowable torque of 250 lb-ft at the 64 tooth gear in the transmission with the PTO on one opening only. With PTOs mounted on both openings the maximum allowable torque at the 64 tooth gear in the transmission is 200 lb-ft. For a more precise evaluation of your PTO application refer to the Allison Body Builders Book, Section F, PTO Systems Provisions.
4. The 252 Series for MY2015 and later GM C/K series Cab/Chassis order wiring harness part number 75-P-33. For 2007-2014 order Chelsea part number 329620X. This harness must be ordered separately and is required for proper PTO to Engine interface operation. Refer to GM UI Bulletin #80.
5. Only the 12V B option shifter can be used on this application.
6. The left PTO aperture opening on this application is not usable due to engine fuel lines blocking the opening.

AIS-2

1. The A465 (MY600) transmissions in Isuzu trucks started TCC Lock-up in PTO Mode in MY2010. The transmission build start dates were June 2010. The vehicle code for MY2010 is "VN60."
2. The A460 (MY400) and A465 (MY600) share the same transmission housing and both have a "shelf" in the aperture that interferes with the ratio gear of the 272, starting with the K ratio. The older 270 series fit with higher ratios because the input ratio gear was not as wide.



HINO



Parker | Chelsea

ENGINEERING YOUR SUCCESS.

**WARNING — User Responsibility**

FAILURE OR IMPROPER SELECTION OR IMPROPER USE OF THE PRODUCTS DESCRIBED HEREIN OR RELATED ITEMS CAN CAUSE DEATH, PERSONAL INJURY AND PROPERTY DAMAGE.

This document and other information from Parker Hannifin Corporation, its subsidiaries and authorized distributors provide product or system options for further investigation by users having technical expertise.

The user, through its own analysis and testing, is solely responsible for making the final selection of the system and components and assuring that all performance, endurance, maintenance, safety and warning requirements of the application are met. The user must analyze all aspects of the application, follow applicable industry standards, and follow the information concerning the product in the current product catalog and in any other materials provided from Parker or its subsidiaries or authorized distributors.

To the extent that Parker or its subsidiaries or authorized distributors provide component or system options based upon data or specifications provided by the user, the user is responsible for determining that such data and specifications are suitable and sufficient for all applications and reasonably foreseeable uses of the components or systems.

Offer of Sale

The items described in this document are hereby offered for sale by Parker Hannifin Corporation, its subsidiaries or its authorized distributors. This offer and its acceptance are governed by the provisions stated in the "Offer of Sale".



WARNING: This product can expose you to chemicals including Lead and Lead Compounds, and Di(2-ethylhexyl)phthalate (DEHP) which are known to the State of California to cause cancer and birth defects or other reproductive harm. For more information go to www.P65Warnings.ca.gov

© Copyright 2022, Parker Hannifin Corporation, All Rights Reserved

Transmission Make and Model	PTO Appl. Number	Number Forward Speeds	Teeth in PTO Driver
A465	AIS-2	6	L69
2200 RDS (Hino L6 Series)	ALL-15	5	L64-R64
2500 RDS (Hino L6 Series)	ALL-15	5	L64-R64
2500 RDS (Hino L7 Series)	ALL-15	5	L64-R64
3000 RDS (Hino L7 Series)	ALL-13	6	L64-R64
3000 RDS (Hino XL7 Series)	ALL-13	6	L68-R68
3000 RDS (Hino XL8 Series)	ALL-13	6	L68-R68
3500 RDS (Hino XL7 Series)	ALL-13	6	L68-R68
3500 RDS (Hino XL8 Series)	ALL-13	6	L68-R68



IMPORTANT: See Safety Information in Section 1 of the Chelsea Applications catalog HY25-3000/US

Transmission PTO Driver & Apertures (Viewed from Rear of Transmission)
L-Left Side R-Right Side B-Bottom Side T-Top Side CS-Countershaft
For transmissions not listed, contact your authorized Chelsea Distributor.

AIS-2

HINO

CHELSEA®

A465 (Isuzu Number for MY600)
MO36A6 (Mitsubishi/Fuso Number for MY600)
MY600

LEFT SIDE ONLY

TRANSMISSION GEAR DATA:

L.S. 06-BOLT Opening Gear FORWARD of Centerline
69 Teeth - SPUR

PITCH LINE TO APERTURE FACE:

1.0880" (27.6352MM)

CAUTION: Application Approval Required for PTO Output Shaft Speeds Above 2500 RPM

PTO Model	Torq	Dir Rot	Engine %		Filler Block	Adapter Assy	Stud Kit	PTO Model	Torq	Dir Rot	Engine %		Filler Block	Adapter Assy	Stud Kit
	I / C †		Fwd	Rev					I / C †		Fwd	Rev			

ONE SPEED - TWO GEAR POWERSHIFT (AIR OR HYDRAULIC)

272AAKUP-*5 (1)	158 C	Eng	69				Furnished
272ABKUP-*5 (2)	129 C	Eng	84				Furnished
272ACKUP-*5 (3)	106 C	Eng	102				Furnished
272ADKUP-*5 (4)	89 C	Eng	122				Furnished

† I = Intermittent Torque Only - De-rate Torque Rating 30% for Continuous Duty.

C = Continuous or Intermittent Torque - No need to De-Rate Torque Rating.

IMPORTANT: Refer to the back of this transmission section and read all notes associated with this application page. Some notes may affect the proper PTO selection.

Hino

- (1) Input Gear Part No. 5-P-1515-1X
- (2) Input Gear Part No. 5-P-1515-2X
- (3) Input Gear Part No. 5-P-1515-3X
- (4) Input Gear Part No. 5-P-1515-4X

3000 RDS (L7, XL7 and XL8 Series)
3500 RDS (XL7 and XL8 Series)

LEFT SIDE ONLY

RIGHT SIDE ONLY

TRANSMISSION GEAR DATA:

L.S. 10-BOLT Opening Gear FORWARD of Centerline
68 Teeth - L.H. HELIX

PITCH LINE TO APERTURE FACE:

1.7800" (45.2100MM)

TRANSMISSION GEAR DATA:

R.S. 10-BOLT Opening Gear FORWARD of Centerline
68 Teeth - L.H. HELIX

PITCH LINE TO APERTURE FACE:

1.7800" (45.2100MM)

CAUTION: Application Approval Required for PTO Output Shaft Speeds Above 2500 RPM

PTO Model	Torq I / C †	Dir Rot	Engine %		Filler Block	Adapter Assy	Stud Kit	PTO Model	Torq I / C †	Dir Rot	Engine %		Filler Block	Adapter Assy	Stud Kit
			Fwd	Rev							Fwd	Rev			

ONE SPEED - TWO GEAR - CONSTANT MESH

267SBFJP-*5 (4)	402 I	Eng	72				Furnished	267SBFJP-*3 (4)	402 I	Eng	72				Furnished
267SDFJP-*5 (3)	390 I	Eng	87				Furnished	267SDFJP-*3 (3)	390 I	Eng	87				Furnished
267SGFJP-*5 (2)	360 I	Eng	103				Furnished	267SGFJP-*3 (2)	360 I	Eng	103				Furnished
267SMFJP-*5 (5)	318 I	Eng	129				Furnished	267SMFJP-*3 (5)	318 I	Eng	129				Furnished
267SSFJP-*5 (1)	265 I	Eng	161				Furnished	267SSFJP-*3 (1)	265 I	Eng	161				Furnished
267XBFJP-*5 (26)	335 I	Eng	72				Furnished	267XBFJP-*3 (26)	335 I	Eng	72				Furnished
267XDFJP-*5 (27)	325 I	Eng	87				Furnished	267XDFJP-*3 (27)	325 I	Eng	87				Furnished
267XGFJP-*5 (28)	300 I	Eng	103				Furnished	267XGFJP-*3 (28)	300 I	Eng	103				Furnished
267XMFJP-*5 (29)	265 I	Eng	129				Furnished	267XMFJP-*3 (29)	265 I	Eng	129				Furnished
267XSFJP-*5 (1)	250 I	Eng	161				Furnished	267XSFJP-*3 (1)	250 I	Eng	161				Furnished
287GBFJP-*5 (17)	300 C	Eng	60				Furnished	287GBFJP-*3 (17)	300 C	Eng	60				Furnished
287GBFJP-*8 (17)	300 C	Eng	56				Furnished	287GBFJP-*3 (17)	300 C	Eng	56				Furnished
287GCFJP-*5 (18)	390 C	Eng	72				Furnished	287GCFJP-*3 (18)	390 C	Eng	72				Furnished
287GCFJP-*8 (18)	390 C	Eng	68				Furnished	287GCFJP-*3 (18)	390 C	Eng	68				Furnished
287GDFJP-*5 (19)	390 C	Eng	87				Furnished	287GDFJP-*3 (19)	390 C	Eng	87				Furnished
287GDFJP-*8 (19)	390 C	Eng	81				Furnished	287GDFJP-*3 (19)	390 C	Eng	81				Furnished
287GGFJP-*5 (20)	360 C	Eng	103				Furnished	287GGFJP-*3 (20)	360 C	Eng	103				Furnished
287GGFJP-*8 (20)	360 C	Eng	96				Furnished	287GGFJP-*3 (20)	360 C	Eng	96				Furnished
287GKFJP-*5 (21)	340 C	Eng	115				Furnished	287GKFJP-*3 (21)	340 C	Eng	115				Furnished
287GMFJP-*5 (22)	318 C	Eng	129				Furnished	287GMFJP-*3 (22)	318 C	Eng	129				Furnished
287GMFJP-*8 (22)	318 C	Eng	119				Furnished	287GMFJP-*3 (22)	318 C	Eng	119				Furnished
287GPFJP-*5 (23)	290 C	Eng	144				Furnished	287GPFJP-*3 (23)	290 C	Eng	144				Furnished
287GPFJP-*8 (23)	290 C	Eng	132				Furnished	287GPFJP-*3 (23)	290 C	Eng	132				Furnished
287GSFJP-*5 (24)	265 C	Eng	161				Furnished	287GSFJP-*3 (24)	265 C	Eng	161				Furnished
287GSFJP-*8 (24)	265 C	Eng	147				Furnished	287GSFJP-*3 (24)	265 C	Eng	147				Furnished
287GTFJP-*5 (25)	240 C	Eng	180				Furnished	287GTFJP-*3 (25)	240 C	Eng	180				Furnished
287GTFJP-*8 (16)	240 C	Eng	173				Furnished	287GTFJP-*3 (16)	240 C	Eng	173				Furnished
877XAFJP-*5 (7)	591 C	Eng	82				Furnished	877XAFJP-*3 (7)	591 C	Eng	82				Furnished
877XBFJP-*5 (8)	557 C	Eng	87				Furnished	877XBFJP-*3 (8)	557 C	Eng	87				Furnished
877XCFJP-*5 (9)	522 C	Eng	93				Furnished	877XCFJP-*3 (9)	522 C	Eng	93				Furnished
877XDFJP-*5 (10)	490 C	Eng	99				Furnished	877XDFJP-*3 (10)	490 C	Eng	99				Furnished
877XEFJP-*5 (11)	429 C	Eng	113				Furnished	877XEFJP-*3 (11)	429 C	Eng	113				Furnished

† I = Intermittent Torque Only - De-rate Torque Rating 30% for Continuous Duty.

C = Continuous or Intermittent Torque - No need to De-Rate Torque Rating.

IMPORTANT: Refer to the back of this transmission section and read all notes associated with this application page. Some notes may affect the proper PTO selection.

CAUTION: Chelsea Recommends the Power Take-Off (PTO) installation on the 3000/4000 Series Transmissions to utilize a Vehicle Interface Module, or Chassis Manufacturer's equivalent controller to incorporate all the PTO control features available, this includes the "PTO Request" and "PTO Enable Output" feature. The "PTO Enable" circuit signals the Transmission Control Module (TCM) to maintain line pressure to the PTO. Failure to provide this signal may not be sufficient to the PTO. This may cause damage to the PTO and /or Transmission. Please see the Allison Transmission website and individual chassis manufacturer for installation details.

- 1) Input Gear Part No. 5-P-1173
- 2) Input Gear Part No. 5-P-1225
- 3) Input Gear Part No. 5-P-1293
- 4) Input Gear Part No. 5-P-1350
- 5) Input Gear Part No. 5-P-1351
- 7) Input Gear Part No. 5-P-1428-11X

- (8) Input Gear Part No. 5-P-1428-12X
- (9) Input Gear Part No. 5-P-1428-3X
- (10) Input Gear Part No. 5-P-1428-4X
- (11) Input Gear Part No. 5-P-1428-5X
- (16) Input Gear Part No. 5-P-1491-10X
- (17) Input Gear Part No. 5-P-1491-1X

- (18) Input Gear Part No. 5-P-1491-2X
- (19) Input Gear Part No. 5-P-1491-3X
- (20) Input Gear Part No. 5-P-1491-4X
- (21) Input Gear Part No. 5-P-1491-5X
- (22) Input Gear Part No. 5-P-1491-6X
- (23) Input Gear Part No. 5-P-1491-7X

- (24) Input Gear Part No. 5-P-1491-8X
- (25) Input Gear Part No. 5-P-1491-9X
- (26) Input Gear Part No. 5-P-912
- (27) Input Gear Part No. 5-P-913
- (28) Input Gear Part No. 5-P-914
- (29) Input Gear Part No. 5-P-915

ALL-13

HINO

CHELSEA®

3000 RDS (L7, XL7 and XL8 Series)
3500 RDS (XL7 and XL8 Series)

LEFT SIDE ONLY

RIGHT SIDE ONLY

TRANSMISSION GEAR DATA:

L.S. 10-BOLT Opening Gear FORWARD of Centerline
68 Teeth - L.H. HELIX

PITCH LINE TO APERTURE FACE:

1.7800" (45.2100MM)

TRANSMISSION GEAR DATA:

R.S. 10-BOLT Opening Gear FORWARD of Centerline
68 Teeth - L.H. HELIX

PITCH LINE TO APERTURE FACE:

1.7800" (45.2100MM)

CAUTION: Application Approval Required for PTO Output Shaft Speeds Above 2500 RPM

PTO Model	Torq l / C †	Dir Rot	Engine %		Filler Block	Adapter Assy	Stud Kit	PTO Model	Torq l / C †	Dir Rot	Engine %		Filler Block	Adapter Assy	Stud Kit
			Fwd	Rev							Fwd	Rev			

ONE SPEED - TWO GEAR - CONSTANT MESH

877XFFJP-*5 (12)	379 C	Eng	128			Furnished	877XFFJP-*3 (12)	379 C	Eng	128					Furnished
877XGFJP-*5 (13)	334 C	Eng	145			Furnished	877XGFJP-*3 (13)	334 C	Eng	145					Furnished
877XHFJP-*5 (14)	315 C	Eng	154			Furnished	877XHFJP-*3 (14)	315 C	Eng	154					Furnished
877XJFJP-*5 (15)	295 C	Eng	164			Furnished	877XJFJP-*3 (15)	295 C	Eng	164					Furnished
877XKFJP-*5 (6)	357 C	Eng	136			Furnished	877XKFJP-*3 (6)	357 C	Eng	136					Furnished

ONE SPEED - TWO GEAR - POWERSHIFT (HYDRAULIC)

280GBFJP-*5 (17)	300 C	Eng	60			Furnished	280GBFJP-*3 (17)	300 C	Eng	60					Furnished
280GBFJP-*8 (17)	300 C	Eng	56			Furnished	280GBFJP-*8 (17)	300 C	Eng	56					Furnished
280GCFJP-*5 (18)	390 C	Eng	72			Furnished	280GCFJP-*3 (18)	390 C	Eng	72					Furnished
280GCFJP-*8 (18)	390 C	Eng	68			Furnished	280GCFJP-*8 (18)	390 C	Eng	68					Furnished
280GDFJP-*5 (19)	390 C	Eng	87			Furnished	280GDFJP-*3 (19)	390 C	Eng	87					Furnished
280GDFJP-*8 (19)	390 C	Eng	81			Furnished	280GDFJP-*8 (19)	390 C	Eng	81					Furnished
280GGFJP-*5 (20)	360 C	Eng	103			Furnished	280GGFJP-*3 (20)	360 C	Eng	103					Furnished
280GGFJP-*8 (20)	360 C	Eng	96			Furnished	280GGFJP-*8 (20)	360 C	Eng	96					Furnished
280GKFJP-*5 (21)	340 C	Eng	115			Furnished	280GKFJP-*3 (21)	340 C	Eng	115					Furnished
280GMFJP-*5 (22)	318 C	Eng	129			Furnished	280GMFJP-*3 (22)	318 C	Eng	129					Furnished
280GMFJP-*8 (22)	318 C	Eng	119			Furnished	280GMFJP-*8 (22)	318 C	Eng	119					Furnished
280GPFJP-*5 (23)	290 C	Eng	144			Furnished	280GPFJP-*3 (23)	290 C	Eng	144					Furnished
280GPFJP-*8 (23)	290 C	Eng	132			Furnished	280GPFJP-*8 (23)	290 C	Eng	132					Furnished
280GSFJP-*5 (24)	265 C	Eng	161			Furnished	280GSFJP-*3 (24)	265 C	Eng	161					Furnished
280GSFJP-*8 (24)	265 C	Eng	147			Furnished	280GSFJP-*8 (24)	265 C	Eng	147					Furnished
280GTFJP-*5 (25)	240 C	Eng	180			Furnished	280GTFJP-*3 (25)	240 C	Eng	180					Furnished
280GTFJP-*8 (16)	240 C	Eng	173			Furnished	280GTFJP-*8 (16)	240 C	Eng	173					Furnished
870XAFJP-*5 (7)	591 C	Eng	82			Furnished	870XAFJP-*3 (7)	591 C	Eng	82					Furnished
870XBFJP-*5 (8)	557 C	Eng	87			Furnished	870XBFJP-*3 (8)	557 C	Eng	87					Furnished
870XCFJP-*5 (9)	522 C	Eng	93			Furnished	870XCFJP-*3 (9)	522 C	Eng	93					Furnished
870XDFJP-*5 (10)	490 C	Eng	99			Furnished	870XDFJP-*3 (10)	490 C	Eng	99					Furnished
870XEFJP-*5 (11)	429 C	Eng	113			Furnished	870XEFJP-*3 (11)	429 C	Eng	113					Furnished
870XFFJP-*5 (12)	379 C	Eng	128			Furnished	870XFFJP-*3 (12)	379 C	Eng	128					Furnished
870XGFJP-*5 (13)	334 C	Eng	145			Furnished	870XGFJP-*3 (13)	334 C	Eng	145					Furnished

† I = Intermittent Torque Only - De-rate Torque Rating 30% for Continuous Duty.

C = Continuous or Intermittent Torque - No need to De-Rate Torque Rating.

IMPORTANT: Refer to the back of this transmission section and read all notes associated with this application page. Some notes may affect the proper PTO selection.

CAUTION: Chelsea Recommends the Power Take-Off (PTO) installation on the 3000/4000 Series Transmissions to utilize a Vehicle Interface Module, or Chassis Manufacturer's equivalent controller to incorporate all the PTO control features available, this includes the "PTO Request" and "PTO Enable Output" feature. The "PTO Enable" circuit signals the Transmission Control Module (TCM) to maintain line pressure to the PTO. Failure to provide this signal may not be sufficient to the PTO. This may cause damage to the PTO and /or Transmission. Please see the Allison Transmission website and individual chassis manufacturer for installation details.

- (6) Input Gear Part No. 5-P-1428-10X
- (7) Input Gear Part No. 5-P-1428-11X
- (8) Input Gear Part No. 5-P-1428-12X
- (9) Input Gear Part No. 5-P-1428-3X
- (10) Input Gear Part No. 5-P-1428-4X
- (11) Input Gear Part No. 5-P-1428-5X
- (12) Input Gear Part No. 5-P-1428-6X
- (13) Input Gear Part No. 5-P-1428-7X
- (14) Input Gear Part No. 5-P-1428-8X
- (15) Input Gear Part No. 5-P-1428-9X
- (16) Input Gear Part No. 5-P-1491-10X
- (17) Input Gear Part No. 5-P-1491-1X
- (18) Input Gear Part No. 5-P-1491-2X
- (19) Input Gear Part No. 5-P-1491-3X
- (20) Input Gear Part No. 5-P-1491-4X
- (21) Input Gear Part No. 5-P-1491-5X
- (22) Input Gear Part No. 5-P-1491-6X
- (23) Input Gear Part No. 5-P-1491-7X
- (24) Input Gear Part No. 5-P-1491-8X
- (25) Input Gear Part No. 5-P-1491-9X

Hino

3000 RDS (L7, XL7 and XL8 Series)
3500 RDS (XL7 and XL8 Series)

LEFT SIDE ONLY

RIGHT SIDE ONLY

TRANSMISSION GEAR DATA:

L.S. 10-BOLT Opening Gear FORWARD of Centerline
68 Teeth - L.H. HELIX

PITCH LINE TO APERTURE FACE:

1.7800" (45.2100MM)

TRANSMISSION GEAR DATA:

R.S. 10-BOLT Opening Gear FORWARD of Centerline
68 Teeth - L.H. HELIX

PITCH LINE TO APERTURE FACE:

1.7800" (45.2100MM)

CAUTION: Application Approval Required for PTO Output Shaft Speeds Above 2500 RPM

PTO Model	Torq I / C †	Dir Rot	Engine %		Filler Block	Adapter Assy	Stud Kit	PTO Model	Torq I / C †	Dir Rot	Engine %		Filler Block	Adapter Assy	Stud Kit
			Fwd	Rev							Fwd	Rev			

ONE SPEED - TWO GEAR - POWERSHIFT (HYDRAULIC)

870XHJJP-*5 (14)	315 C	Eng	154				Furnished	870XHJJP-*3 (14)	315 C	Eng	154				Furnished
870XJFJP-*5 (15)	295 C	Eng	164				Furnished	870XJFJP-*3 (15)	295 C	Eng	164				Furnished

ONE SPEED - POWERSHIFT (HYDRAULIC) EXTENDED SHAFT

870LAFJW-*5 (7)	591 C	Eng	82				Furnished	870LAFJW-*3 (7)	591 C	Eng	82				Furnished
870LBFJW-*5 (8)	557 C	Eng	87				Furnished	870LBFJW-*3 (8)	557 C	Eng	87				Furnished
870LCFJW-*5 (9)	522 C	Eng	93				Furnished	870LCFJW-*3 (9)	522 C	Eng	93				Furnished
870LDFJW-*5 (10)	490 C	Eng	99				Furnished	870LDFJW-*3 (10)	490 C	Eng	99				Furnished
870LEFJW-*5 (11)	429 C	Eng	113				Furnished	870LEFJW-*3 (11)	429 C	Eng	113				Furnished
870LFFJW-*5 (12)	379 C	Eng	128				Furnished	870LFFJW-*3 (12)	379 C	Eng	128				Furnished
870LGFJW-*5 (13)	334 C	Eng	145				Furnished	870LGFJW-*3 (13)	334 C	Eng	145				Furnished
870LHFJW-*5 (14)	315 C	Eng	154				Furnished	870LHFJW-*3 (14)	315 C	Eng	154				Furnished
890LAFJW-*5 (7)	591 C	Eng	82				Furnished	890RAFJW-*5 (7)	591 C	Eng	82				Furnished
890LBFJW-*5 (8)	557 C	Eng	87				Furnished	890RBFJW-*5 (8)	557 C	Eng	87				Furnished
890LCFJW-*5 (9)	522 C	Eng	93				Furnished	890RCFJW-*5 (9)	522 C	Eng	93				Furnished
890LDFJW-*5 (10)	490 C	Eng	99				Furnished	890RDFJW-*5 (10)	490 C	Eng	99				Furnished
890LEFJW-*5 (11)	429 C	Eng	113				Furnished	890REFJW-*5 (11)	429 C	Eng	113				Furnished
890LFFJW-*5 (12)	379 C	Eng	128				Furnished	890RFFJW-*5 (12)	379 C	Eng	128				Furnished
890LGFJW-*5 (13)	334 C	Eng	145				Furnished	890RGFJW-*5 (13)	334 C	Eng	145				Furnished
890LHFJW-*5 (14)	315 C	Eng	154				Furnished	890RHFJW-*5 (14)	315 C	Eng	154				Furnished

ONE SPEED - CONSTANT MESH EXTENDED SHAFT

877LAFJW-*5 (7)	591 C	Eng	82				Furnished	877LAFJW-*3 (7)	591 C	Eng	82				Furnished
877LBFJW-*5 (8)	557 C	Eng	87				Furnished	877LBFJW-*3 (8)	557 C	Eng	87				Furnished
877LCFJW-*5 (9)	522 C	Eng	93				Furnished	877LCFJW-*3 (9)	522 C	Eng	93				Furnished
877LDFJW-*5 (10)	490 C	Eng	99				Furnished	877LDFJW-*3 (10)	490 C	Eng	99				Furnished
877LEFJW-*5 (11)	429 C	Eng	113				Furnished	877LEFJW-*3 (11)	429 C	Eng	113				Furnished
877LFFJW-*5 (12)	379 C	Eng	128				Furnished	877LFFJW-*3 (12)	379 C	Eng	128				Furnished
877LGFJW-*5 (13)	334 C	Eng	145				Furnished	877LGFJW-*3 (13)	334 C	Eng	145				Furnished
877LHFJW-*5 (14)	315 C	Eng	154				Furnished	877LHFJW-*3 (14)	315 C	Eng	154				Furnished
897LAFJW-*5 (7)	591 C	Eng	82				Furnished	897RAFJW-*5 (7)	591 C	Eng	82				Furnished
897LBFJW-*5 (8)	557 C	Eng	87				Furnished	897RBFJW-*5 (8)	557 C	Eng	87				Furnished

Continued on Next Page

† I = Intermittent Torque Only - De-rate Torque Rating 30% for Continuous Duty.

C = Continuous or Intermittent Torque - No need to De-Rate Torque Rating.

IMPORTANT: Refer to the back of this transmission section and read all notes associated with this application page. Some notes may affect the proper PTO selection.

CAUTION: Chelsea Recommends the Power Take-Off (PTO) installation on the 3000/4000 Series Transmissions to utilize a Vehicle Interface Module, or Chassis Manufacturer's equivalent controller to incorporate all the PTO control features available, this includes the "PTO Request" and "PTO Enable Output" feature. The "PTO Enable" circuit signals the Transmission Control Module (TCM) to maintain line pressure to the PTO. Failure to provide this signal may not be sufficient to the PTO. This may cause damage to the PTO and /or Transmission. Please see the Allison Transmission website and individual chassis manufacturer for installation details.

- (7) Input Gear Part No. 5-P-1428-11X
- (8) Input Gear Part No. 5-P-1428-12X
- (9) Input Gear Part No. 5-P-1428-3X
- (10) Input Gear Part No. 5-P-1428-4X
- (11) Input Gear Part No. 5-P-1428-5X
- (12) Input Gear Part No. 5-P-1428-6X

- (13) Input Gear Part No. 5-P-1428-7X
- (14) Input Gear Part No. 5-P-1428-8X
- (15) Input Gear Part No. 5-P-1428-9X

ALL-13

HINO

CHELSEA®

3000 RDS (L7, XL7 and XL8 Series)
3500 RDS (XL7 and XL8 Series)

LEFT SIDE ONLY

RIGHT SIDE ONLY

TRANSMISSION GEAR DATA:

L.S. 10-BOLT Opening Gear FORWARD of Centerline
68 Teeth - L.H. HELIX

PITCH LINE TO APERTURE FACE:

1.7800" (45.2100MM)

TRANSMISSION GEAR DATA:

R.S. 10-BOLT Opening Gear FORWARD of Centerline
68 Teeth - L.H. HELIX

PITCH LINE TO APERTURE FACE:

1.7800" (45.2100MM)

CAUTION: Application Approval Required for PTO Output Shaft Speeds Above 2500 RPM

PTO Model	Torq	Dir Rot	Engine %		Filler Block	Adapter Assy	Stud Kit	PTO Model	Torq	Dir Rot	Engine %		Filler Block	Adapter Assy	Stud Kit
	I / C †		Fwd	Rev					I / C †		Fwd	Rev			

ONE SPEED - CONSTANT MESH EXTENDED SHAFT

897LCFJW-*5 (9)	522 C	Eng	93				Furnished	897RCFJW-*5 (9)	522 C	Eng	93				Furnished
897LDFJW-*5 (10)	490 C	Eng	99				Furnished	897RDFJW-*5 (10)	490 C	Eng	99				Furnished
897LEFJW-*5 (11)	429 C	Eng	113				Furnished	897REFJW-*5 (11)	429 C	Eng	113				Furnished
897LFFJW-*5 (12)	379 C	Eng	128				Furnished	897RFJW-*5 (12)	379 C	Eng	128				Furnished
897LGFJW-*5 (13)	334 C	Eng	145				Furnished	897RGFJW-*5 (13)	334 C	Eng	145				Furnished
897LHFJW-*5 (14)	315 C	Eng	154				Furnished	897RHFJW-*5 (14)	315 C	Eng	154				Furnished

† I = Intermittent Torque Only - De-rate Torque Rating 30% for Continuous Duty.

C = Continuous or Intermittent Torque - No need to De-Rate Torque Rating.

IMPORTANT: Refer to the back of this transmission section and read all notes associated with this application page. Some notes may affect the proper PTO selection.

CAUTION: Chelsea Recommends the Power Take-Off (PTO) installation on the 3000/4000 Series Transmissions to utilize a Vehicle Interface Module, or Chassis Manufacturer's equivalent controller to incorporate all the PTO control features available, this includes the "PTO Request" and "PTO Enable Output" feature. The "PTO Enable" circuit signals the Transmission Control Module (TCM) to maintain line pressure to the PTO. Failure to provide this signal may not be sufficient to the PTO. This may cause damage to the PTO and /or Transmission. Please see the Allison Transmission website and individual chassis manufacturer for installation details.

Hino

2200 RDS (L6 Series)
2500 RDS (L6 Series)

LEFT SIDE ONLY

RIGHT SIDE ONLY

TRANSMISSION GEAR DATA:

L.S. 06-BOLT Opening Gear FORWARD of Centerline
64 Teeth - SPUR

PITCH LINE TO APERTURE FACE:

1.0080" (25.6000MM)

TRANSMISSION GEAR DATA:

R.S. 06-BOLT Opening Gear FORWARD of Centerline
64 Teeth - SPUR

PITCH LINE TO APERTURE FACE:

1.0080" (25.6032MM)

ONE SPEED - TWO GEAR - MECHANICAL SHIFT

442GBHVP-*5 (3)	215 I	Eng	96	Furnished	442GBHVP-*3 (3)	215 I	Eng	96	Furnished
442GBHVX-*5 (3)	150 I	Eng	96	Furnished	442GBHVX-*3 (3)	150 I	Eng	96	Furnished
442GFHVP-*5 (2)	165 I	Eng	151	Furnished	442GFHVP-*3 (2)	165 I	Eng	151	Furnished

ONE SPEED - TWO GEAR POWERSHIFT (AIR OR HYDRAULIC)

272GAHVP-*5 (5)	294 C	Eng	85	Furnished	272GAHVP-*3 (5)	294 C	Eng	85	Furnished
272GBHVP-*5 (6)	240 C	Eng	104	Furnished	272GBHVP-*3 (6)	240 C	Eng	104	Furnished
272GCHVP-*5 (7)	198 C	Eng	126	Furnished	272GCHVP-*3 (7)	198 C	Eng	126	Furnished
272GDHVP-*5 (8)	166 C	Eng	151	Furnished	272GDHVP-*3 (8)	166 C	Eng	151	Furnished

ONE SPEED - POWERSHIFT LOW PROFILE (AIR OR HYDRAULIC)

272NAHVP-*3 (5)	294 C	Eng	85	Furnished	272NAHVP-*5 (5)	294 C	Eng	85	Furnished
272NBHVP-*3 (6)	240 C	Eng	104	Furnished	272NBHVP-*5 (6)	240 C	Eng	104	Furnished
272NCHVP-*3 (7)	198 C	Eng	126	Furnished	272NCHVP-*5 (7)	198 C	Eng	126	Furnished
272NDHVP-*3 (8)	166 C	Eng	151	Furnished	272NDHVP-*5 (8)	166 C	Eng	151	Furnished

ONE SPEED - TWO GEAR - POWERSHIFT (HYDRAULIC)

252GDHVP-*5 (1)	120 I	Eng	122	Furnished	252GDHVX-*5 (1)	120 I	Eng	122	Furnished
252GMHVP-*5 (4)	50 I	Eng	178	Furnished	252GMHVX-*5 (4)	50 I	Eng	178	Furnished

GEARED ADAPTERS

626GHVX-4HV (2)	250 I	Opp	7-A-140(P)(9)	Furnished	626GHVX-3HV (2)	250 I	Opp	7-A-140(P)(9)	Furnished
630GHVX-4HV (2)	250 I	Opp	7-A-140(P)(9)	Furnished	630GHVX-3HV (2)	250 I	Opp	7-A-140(P)(9)	Furnished
645GHVX-4HV (2)	250 I	Opp	7-A-140(P)(9)	Furnished	645GHVX-3HV (2)	250 I	Opp	7-A-140(P)(9)	Furnished

† I = Intermittent Torque Only - De-rate Torque Rating 30% for Continuous Duty.

C = Continuous or Intermittent Torque - No need to De-Rate Torque Rating.

IMPORTANT: Refer to the back of this transmission section and read all notes associated with this application page. Some notes may affect the proper PTO selection.

CAUTION: Chelsea Recommends the Power Take-Off (PTO) installation on the 3000/4000 Series Transmissions to utilize a Vehicle Interface Module, or Chassis Manufacturer's equivalent controller to incorporate all the PTO control features available, this includes the "PTO Request" and "PTO Enable Output" feature. The "PTO Enable" circuit signals the Transmission Control Module (TCM) to maintain line pressure to the PTO. Failure to provide this signal may not be sufficient to the PTO. This may cause damage to the PTO and /or Transmission. Please see the Allison Transmission website and individual chassis manufacturer for installation details.

- (1) Input Gear Part No. 5-P-1294
- (2) Input Gear Part No. 5-P-1300
- (3) Input Gear Part No. 5-P-1358
- (4) Input Gear Part No. 5-P-1386
- (5) Input Gear Part No. 5-P-1516-1X
- (6) Input Gear Part No. 5-P-1516-2X
- (7) Input Gear Part No. 5-P-1516-3X
- (8) Input Gear Part No. 5-P-1516-4X
- (9) Filler block furnished with PTO

Hino Notes

AIS-2

1. The A465 (MY600) transmissions in Isuzu trucks started TCC Lock-up in PTO Mode in MY2010. The transmission build start dates were June 2010. The vehicle code for MY2010 is "VN60."
2. The A460 (MY400) and A465 (MY600) share the same transmission housing and both have a "shelf" in the aperture that interferes with the ratio gear of the 272, starting with the K ratio. The older 270 series fit with higher ratios because the input ratio gear was not as wide.

ALL-13

1. 890/897 Series - The Combined Weight of Pump, Fittings and Hoses Should Not Exceed 120 Lbs. Refer to Owner's Manual (HY25-1890- M1/US) for Complete Details.
2. When direct mounting a Parker P2 060 piston pump to a 267 Series PTO on the left (drivers) side opening, the PTO must be ordered as a 3 assembly arrangement for pump clearance.
3. All models require a hose assembly. For the 267 Series, use 329130-1X for left side, 329130-6X for top right and 329130-4X for right side. THESE HOSE ASSEMBLIES MUST BE ORDERED SEPARATELY. For 280/287, 870/877 and 890/897 Series - All Mounting Hardware and Hose Assemblies are Included with the Unit.
4. The 267 Series is not available in the 3 arrangement with an XK output due to interference with the pressure lube fitting.
5. Wiring harness 379926 must be used in 2003 GM trucks for the 277, 278 and 859 Series PTOs if the GM provided in-dash PTO switch is used to control PTO operations.
6. Do not use adapter gear assemblies on Allison 3000/4000 Series Automatic Transmissions.
7. Quiet Gear™ input option QT is available on 870/877 and 870L/877L Series PTOs.
8. For an 870-XL and 877-XL (870L and 877L) Extended Shaft PTOs, the transmission bracket (50-P-XXX) and bolt kit (329928-1X) must be ordered separately: Left Side 5 Arrangement use 50-P-162, Left Side 3 Arrangement use 50-P-164, Right Side 5 Arrangement use 50-P-161, Right Side 3 Arrangement use 50-P-157.

ALL-15

1. There is a torque converter lock up feature available with the 1000/2000/2400 series transmissions. The torque converter lock up feature comes on and is controlled by the Transmission Control Module (TCM) when a signal is provided to the "PTO Enable" circuit of the TCM by the PTO switch. Lock up will only come on in the "NEUTRAL" and "PARK" positions at 1100 RPM transmission turbine speed. This equates to 1200-1250 RPM or higher engine speed, depending on PTO load. The lock up clutch does not come on automatically in "DRIVE." Refer to the appropriate owner's manual for wiring installation.
2. If the 442 Series is ordered with Pressure Lube, Hose 328075X is supplied with the PTO A Restrictor Orifice, 379896 (442*FHVP) or 379594 (442*BHVP) is required and is shipped with the PTO.
3. 442*B Ratio - DO NOT USE with Geared Adapter.
4. Geared Adapters - 626/630/645 listed on this application page are for the 442 (F Ratio Only) or 272. 442*F Ratio - Use 442ZFHV with (1) 7-A-140 filler block and (1) 328170-94X stud kit when mounting the PTO to one of the adapters listed. 272 - Use 272L*HV (deep mount) with (1) 7-A-140 and (1) 328170-94X. Use 35-P-41 gasket between transmission and adapter. Use filler block (1) 7-A-140 between the adapter and PTO with 35-P-1 or 2 shim gaskets to obtain .006-.012" of backlash between the driver gears.
5. To maintain proper hydraulic pressure to PTO clutch, connect Chelsea specified wire to Allison "PTO Request" circuit wire/pin within transmission TCM. Location of PTO Request wire/pin is dependant on Transmission Location Code. For assistance, contact your local Allison representative or contact Allison Technical Assistance at 1-800-252-5283.
6. Limited Ratios - the K Ratio and above will not fit on this transmission due to adjacent interference with the input ratio gear. In some instances the D ratio will not fit either. There seems to be two variations of the transmission case that effect the D ratio, but we have no way to confirm which case is which.
7. A lube T fitting is required in the oil return cooling line to supply low pressure oil to the idler shaft of the 252 (left side), 272, or 442 Series PTO. The 378840 T fitting is for transmission model 1000 with the SAE #3 bell housing, 378970 T fitting is for the transmission model 1000/2000/2400 with the SAE #2 bell housing, or the low pressure return line may be cut with a tube cutter and a compression T fitting may be installed.
8. MY2003 and after GM C/K Series 4500/5500/6500/7500/8500 Trucks - If using the GM provided in-dash switch, use wiring harness 379924 for the 230/231/270/271/272 Series PTOs. The kits must be ORDERED SEPARATELY.
9. 252 Series PTO - (GM C/K Series 2003-Current) If using the factory provided GM PTO switch, an additional wiring harness is required. MY2003-2006 - Order 329619X; MY2007-2014 - Order 329620X; MY2015-Current - Order 75-P-33. Wiring harnesses must be ordered separately.
10. 272 Low Profile - MY2022+ MACK MD6 chassis has cross-member interference on the driver side and a 272N cannot be used. 272G in a 5 arrangement is recommended if there are no other obstructions.

ISUZU

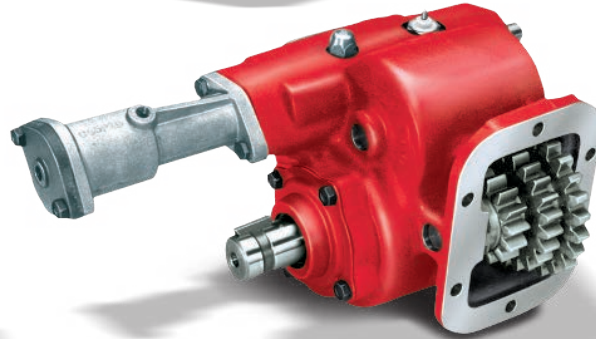
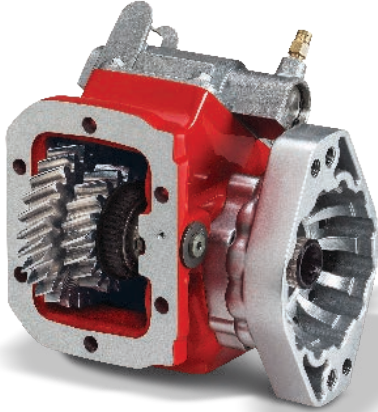
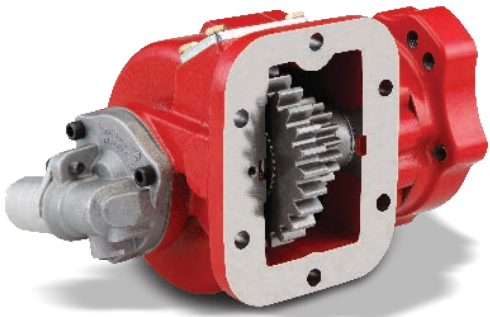

Parker | Chelsea

ENGINEERING YOUR SUCCESS.

**WARNING — User Responsibility**

FAILURE OR IMPROPER SELECTION OR IMPROPER USE OF THE PRODUCTS DESCRIBED HEREIN OR RELATED ITEMS CAN CAUSE DEATH, PERSONAL INJURY AND PROPERTY DAMAGE.

This document and other information from Parker Hannifin Corporation, its subsidiaries and authorized distributors provide product or system options for further investigation by users having technical expertise.

The user, through its own analysis and testing, is solely responsible for making the final selection of the system and components and assuring that all performance, endurance, maintenance, safety and warning requirements of the application are met. The user must analyze all aspects of the application, follow applicable industry standards, and follow the information concerning the product in the current product catalog and in any other materials provided from Parker or its subsidiaries or authorized distributors.

To the extent that Parker or its subsidiaries or authorized distributors provide component or system options based upon data or specifications provided by the user, the user is responsible for determining that such data and specifications are suitable and sufficient for all applications and reasonably foreseeable uses of the components or systems.

Offer of Sale

The items described in this document are hereby offered for sale by Parker Hannifin Corporation, its subsidiaries or its authorized distributors. This offer and its acceptance are governed by the provisions stated in the "Offer of Sale".



WARNING: This product can expose you to chemicals including Lead and Lead Compounds, and Di(2-ethylhexyl)phthalate (DEHP) which are known to the State of California to cause cancer and birth defects or other reproductive harm. For more information go to www.P65Warnings.ca.gov

© Copyright 2022, Parker Hannifin Corporation, All Rights Reserved

ISUZU TRANSMISSION INDEX

Transmission Make and Model	PTO Appl. Number	Number Forward Speeds	Teeth in PTO Driver
450-43LE (Case Serial # 8D3394 and Later)	IZU-12	4	L58
A450-43L	IZU-12	5	L58
A450-43LE	IZU-12	4	L58
A465 (Isuzu Number for MY600)	AIS-2	6	L69
A465ID	AIS-5	6	L69



IMPORTANT: See Safety Information in Section 1 of the Chelsea Applications catalog HY25-3000/US

Transmission PTO Driver & Apertures (Viewed from Rear of Transmission)
L-Left Side R-Right Side B-Bottom Side T-Top Side CS-Countershaft
For transmissions not listed, contact your authorized Chelsea Distributor.

IZU-12

ISUZU

CHELSEA®

450-43LE (Case Serial # 8D3394 and Later)
A450-43L
A455-43-LE

LEFT SIDE ONLY

TRANSMISSION GEAR DATA:

L.S. 06-BOLT Opening Gear FORWARD of Centerline
58 Teeth - SPUR

PITCH LINE TO APERTURE FACE:

1.0880" (27.6352MM)

CAUTION: Application Approval Required for PTO Output Shaft Speeds Above 2500 RPM

PTO Model	Torq	Dir Rot	Engine %		Filler Block	Adapter Assy	Stud Kit	PTO Model	Torq	Dir Rot	Engine %		Filler Block	Adapter Assy	Stud Kit
	I / C †		Fwd	Rev					I / C †		Fwd	Rev			

ONE SPEED - TWO GEAR - MECHANICAL SHIFT

272AAKUP-*5 (1)	199 C	Eng	58				Furnished
272ABKUP-*5 (2)	162 C	Eng	71				Furnished
272ACKUP-*5 (3)	134 C	Eng	86				Furnished

† I = Intermittent Torque Only - De-rate Torque Rating 30% for Continuous Duty.

C = Continuous or Intermittent Torque - No need to De-Rate Torque Rating.

IMPORTANT: Refer to the back of this transmission section and read all notes associated with this application page. Some notes may affect the proper PTO selection.

- (1) Input Gear Part No. 5-P-1515-1X
- (2) Input Gear Part No. 5-P-1515-2X
- (3) Input Gear Part No. 5-P-1515-3X

CHELSEA®

ISUZU

AIS-2

A465 (Isuzu Number for MY600)

LEFT SIDE ONLY

TRANSMISSION GEAR DATA:

L.S. 06-BOLT Opening Gear FORWARD of Centerline
69 Teeth - SPUR

PITCH LINE TO APERTURE FACE:

1.0880" (27.6352MM)

CAUTION: Application Approval Required for PTO Output Shaft Speeds Above 2500 RPM

PTO Model	Torq	Dir Rot	Engine %		Filler Block	Adapter Assy	Stud Kit	PTO Model	Torq	Dir Rot	Engine %		Filler Block	Adapter Assy	Stud Kit
	I / C †		Fwd	Rev					I / C †		Fwd	Rev			

ONE SPEED - TWO GEAR POWERSHIFT (AIR OR HYDRAULIC)

272AAKUP-*5 (1)	158 C	Eng	69				Furnished
272ABKUP-*5 (2)	129 C	Eng	84				Furnished
272ACKUP-*5 (3)	106 C	Eng	102				Furnished
272ADKUP-*5 (4)	89 C	Eng	122				Furnished

† I = Intermittent Torque Only - De-rate Torque Rating 30% for Continuous Duty.

C = Continuous or Intermittent Torque - No need to De-Rate Torque Rating.

IMPORTANT: Refer to the back of this transmission section and read all notes associated with this application page. Some notes may affect the proper PTO selection.

- (1) Input Gear Part No. 5-P-1515-1X
- (2) Input Gear Part No. 5-P-1515-2X
- (3) Input Gear Part No. 5-P-1515-3X
- (4) Input Gear Part No. 5-P-1515-4X

AIS-5

ISUZU

CHELSEA®

A465ID

LEFT SIDE ONLY

TRANSMISSION GEAR DATA:

L.S. 06-BOLT Opening Gear FORWARD of Centerline
69 Teeth - SPUR

PITCH LINE TO APERTURE FACE:

1.0880" (27.6352MM)

CAUTION: Application Approval Required for PTO Output Shaft Speeds Above 2500 RPM

PTO Model	Torq	Dir Rot	Engine %		Filler Block	Adapter Assy	Stud Kit	PTO Model	Torq	Dir Rot	Engine %		Filler Block	Adapter Assy	Stud Kit
	I / C †		Fwd	Rev					I / C †		Fwd	Rev			

ONE SPEED - TWO GEAR POWERSHIFT (AIR OR HYDRAULIC)

272AAKUP-*5 (1)	196 C	Eng	69				Furnished
272ABKUP-*5 (2)	160 C	Eng	84				Furnished
272ACKUP-*5 (3)	132 C	Eng	102				Furnished
272ADKUP-*5 (4)	111 C	Eng	122				Furnished
272AGKUP-*5 (5)	93 C	Eng	145				Furnished
272AKKUP-*5 (6)	83 C	Eng	162				Furnished
272AMKUP-*5 (7)	74 C	Eng	181				Furnished
272APKUP-*5 (8)	67 C	Eng	203				Furnished

† I = Intermittent Torque Only - De-rate Torque Rating 30% for Continuous Duty.

C = Continuous or Intermittent Torque - No need to De-Rate Torque Rating.

IMPORTANT: Refer to the back of this transmission section and read all notes associated with this application page. Some notes may affect the proper PTO selection.

- (1) Input Gear Part No. 5-P-1515-1X (6) Input Gear Part No. 5-P-1515-6X
- (2) Input Gear Part No. 5-P-1515-2X (7) Input Gear Part No. 5-P-1515-7X
- (3) Input Gear Part No. 5-P-1515-3X (8) Input Gear Part No. 5-P-1515-8X
- (4) Input Gear Part No. 5-P-1515-4X
- (5) Input Gear Part No. 5-P-1515-5X

Isuzu Notes

IZU-12

1. The torque ratings shown for the 272 Series are based on the maximum allowable torque capacity of the PTO drive gear in the transmission.
 2. The PTOs shown on this application page will fit Isuzu NQR model trucks with serial number X7901741 and later only.
 3. The PTOs shown on this application page will fit Isuzu NPR model trucks with wheel bases of 109" or 132" and a serial number of X7006763 and later.
 4. The PTOs shown on this application page will also fit the same NPR model trucks with wheel bases of 150" and 176" after August of 1998 and serial number of X7006763 and later.
 5. The serial number is the last eight digits found on the VIN plate which is located in the cab behind the driver.
-

AIS-2

1. The A465 (MY600) transmissions in Isuzu trucks started TCC Lock-up in PTO Mode in MY2010. The transmission build start dates were June 2010. The vehicle code for MY2010 is "VN60."
 2. The A460 (MY400) and A465 (MY600) share the same transmission housing and both have a "shelf" in the aperture that interferes with the ratio gear of the 272, starting with the K ratio. The older 270 series fit with higher ratios because the input ratio gear was not as wide.
-

AIS-5

1. The A465ID (Isuzu Diesel) and A465HD (Hino Diesel) transmissions are available for MY20+



MACK



Parker | Chelsea

ENGINEERING YOUR SUCCESS.

**WARNING — User Responsibility**

FAILURE OR IMPROPER SELECTION OR IMPROPER USE OF THE PRODUCTS DESCRIBED HEREIN OR RELATED ITEMS CAN CAUSE DEATH, PERSONAL INJURY AND PROPERTY DAMAGE.

This document and other information from Parker Hannifin Corporation, its subsidiaries and authorized distributors provide product or system options for further investigation by users having technical expertise.

The user, through its own analysis and testing, is solely responsible for making the final selection of the system and components and assuring that all performance, endurance, maintenance, safety and warning requirements of the application are met. The user must analyze all aspects of the application, follow applicable industry standards, and follow the information concerning the product in the current product catalog and in any other materials provided from Parker or its subsidiaries or authorized distributors.

To the extent that Parker or its subsidiaries or authorized distributors provide component or system options based upon data or specifications provided by the user, the user is responsible for determining that such data and specifications are suitable and sufficient for all applications and reasonably foreseeable uses of the components or systems.

Offer of Sale

The items described in this document are hereby offered for sale by Parker Hannifin Corporation, its subsidiaries or its authorized distributors. This offer and its acceptance are governed by the provisions stated in the "Offer of Sale".



WARNING: This product can expose you to chemicals including Lead and Lead Compounds, and Di(2-ethylhexyl)phthalate (DEHP) which are known to the State of California to cause cancer and birth defects or other reproductive harm. For more information go to www.P65Warnings.ca.gov

© Copyright 2022, Parker Hannifin Corporation, All Rights Reserved

Transmission Make and Model	PTO Appl. Number	Number Forward Speeds	Teeth in PTO Driver
D107	MAK-18	10	L37-R37
D1070	MAK-19	10	L37-R37
DX1070	MAK-16	6	L34-R34
DX1071	MAK-16	6	L34-R34
DX1078	MAK-16	6	L34-R34
DX10780	MAK-16	6	L34-R34
DX10781	MAK-16	6	L34-R34
G1070	MAK-19	7	L37-R37
QL7220	MAK-17	20	L38-R38
T107	MAK-18	6	L37-R37
T1070	MAK-19	12	L37-R37
T1070-B	MAK-19	12	L37-R37
T2050	MAK-25	5	L54-R54
T2050-C	MAK-29	5	L48-R48
T2060	MAK-25	6	L54-R54
T2060-A	MAK-30	6	L40-R40
T2060-C	MAK-29	6	L48-R48
T2070	MAK-25	7	L54-R54
T2070-A (Front Box)	MAK-25	7	L54-R54
T2070-A (Rear Box)	MAK-26	7	L49-R49
T2070-B (Front Box)	MAK-25	7	L54-R54
T2070-B (Rear Box)	MAK-26	7	L49-R49
T2070-C	MAK-29	7	L48-R48
T2070-D (Front Box)	MAK-29	7	L48-R48
T2070-D (Rear Box)	MAK-26	7	L49-R49
T2070-F	MAK-25	7	L54-R54
T2080	MAK-25	8	L54-R54
T2080-B (Front Box)	MAK-25	8	L54-R54
T2080-B (Rear Box)	MAK-26	8	L49-R49
T2080-C	MAK-29	8	L48-R48
T2080-D (Front Box)	MAK-29	8	L48-R48
T2080-D (Rear Box)	MAK-26	8	L49-R49
T2090	MAK-23	9	L54-R54
T2090-L	MAK-23	9	L54-R54
T2100	MAK-24	10	L54-R54
T2110-B (FRONT BOX FOR T2110B)	MAK-24	11	L54-R54



IMPORTANT: See Safety Information in Section 1 of the Chelsea Applications catalog HY25-3000/US

Transmission PTO Driver & Apertures (Viewed from Rear of Transmission)
L-Left Side R-Right Side B-Bottom Side T-Top Side CS-Countershaft
For transmissions not listed, contact your authorized Chelsea Distributor.

MACK TRANSMISSION INDEX

Transmission Make and Model	PTO Appl. Number	Number Forward Speeds	Teeth in PTO Driver
T2110-B (REAR BOX FOR T2110B)	MAK-31	11	L49-R49
T2130 (Front Box)	MAK-23	13	L54-R54
T2130 (Rear Box)	MAK-28	13	L49-R49
T2130-B (Front Box)	MAK-23	13	L54-R54
T2130-B (Rear Box)	MAK-28	12	L49-R49
T2180 (Front Box)	MAK-23	18	L54-R54
T2180 (Rear Box)	MAK-27	18	L49-R49
T2180-B (Front Box)	MAK-23	18	L54-R54
T2180-B (Rear Box)	MAK-27	18	L49-R49
T305	MAK-25	5	L54-R54
T306	MAK-25	6	L54-R54
T306G	MAK-30	6	L40-R40
T307	MAK-25	7	L54-R54
T307M (Front Box)	MAK-25	7	L54-R54
T307M (Rear Box)	MAK-26	7	L49-R49
T308	MAK-25	8	L54-R54
T308M (Front Box)	MAK-25	8	L54-R54
T308M (Rear Box)	MAK-26	8	L49-R49
T309	MAK-23	9	L54-R54
T309L	MAK-23	9	L54-R54
T309LR	MAK-23	9	L54-R54
T310 (T310 is a standard 10 speed with no rear box)	MAK-32	10	L53-R53
T310-M (Front Box)	MAK-32	10	L53-R53
T310-M (Rear Box)	MAK-27	10	L49-R49
T310ME (Front box, same as T-310M, output flange extended for rear mount PTO)	MAK-32	10	L53-R53
T310ME (Rear box, same as T310M, output flange extended for rear mount PTO)	MAK-27	10	L49-R49
T310-MLR (Front Box)	MAK-23	10	L54-R54
T310-MLR (Rear Box)	MAK-27	10	L49-R49
T313H (Front Box)	MAK-23	13	L54-R54
T313H (Rear Box)	MAK-28	13	L49-R49
T313L (Front Box)	MAK-23	13	L54-R54
T313L (Rear Box)	MAK-28	13	L49-R49
T313L21 (Front Box)	MAK-23	13	L54-R54
T313L21 (Rear Box)	MAK-28	13	L49-R49
T313LR (Front Box)	MAK-23	13	L54-R54
T313LR (Rear Box)	MAK-28	13	L49-R49

Mack



IMPORTANT: See Safety Information
in Section 1 of the Chelsea Applications
catalog HY25-3000/US

Transmission PTO Driver & Apertures (Viewed from Rear of Transmission)
L-Left Side R-Right Side B-Bottom Side T-Top Side CS-Countershaft
For transmissions not listed, contact your authorized Chelsea Distributor.

Transmission Make and Model	PTO Appl. Number	Number Forward Speeds	Teeth in PTO Driver
T313LR21 (Front Box)	MAK-23	13	L54-R54
T313LR21 (Rear Box)	MAK-28	13	L49-R49
T318 (Front Box)	MAK-23	18	L54-R54
T318 (Rear Box)	MAK-27	18	L49-R49
T318L (Front Box)	MAK-23	18	L54-R54
T318L (Rear Box)	MAK-27	18	L49-R49
T318L21 (Front Box)	MAK-23	18	L54-R54
T318L21 (Rear Box)	MAK-27	18	L49-R49
T318LR (Front Box)	MAK-23	18	L54-R54
T318LR (Rear Box)	MAK-27	18	L49-R49
T318LR21 (Front Box)	MAK-23	18	L54-R54
T318LR21 (Rear Box)	MAK-27	18	L49-R49
TM308	MAK-33	8	L54-R54
TM308M (Front box)	MAK-23	8	L54-R54
TM308M (Rear Box)	MAK-26	8	L49-R49
TM309	MAK-33	9	L54-R54
TM309M (Front Box)	MAK-23	9	L54-R54
TM309M (Rear Box)	MAK-26	9	L49-R49
TMD12AD (MDrive) High Split Ratio	MAK-34H	12	CS
TMD12AD (MDrive) Low Ratio	MAK-34	12	CS
TMD12AFD (MDrive) High Split Ratio	MAK-34H	12	CS
TMD12AFD (MDrive) Low Ratio	MAK-34	12	CS
TMD12AFD-HD (MDrive) High Split Ratio	MAK-34H	12	CS
TMD12AFD-HD (MDrive) Low Ratio	MAK-34	12	CS
TMD12AFO (MDrive) High Split Ratio	MAK-35H	12	CS
TMD12AFO (MDrive) Low Ratio	MAK-35	12	CS
TMD12AFO-HD (MDrive) High Split Ratio	MAK-35H	12	CS
TMD12AFO-HD (MDrive) Low Ratio	MAK-35	12	CS
TMD12AO (MDrive) Low Ratio	MAK-35	12	CS
TMD12AO (MDrive) High Split Range	MAK-35H	12	CS
TMD13AD (MDrive) High Split Ratio	MAK-34H	13	CS



IMPORTANT: See Safety Information in Section 1 of the Chelsea Applications catalog HY25-3000/US

Transmission PTO Driver & Apertures (Viewed from Rear of Transmission)
L-Left Side R-Right Side B-Bottom Side T-Top Side CS-Countershaft
For transmissions not listed, contact your authorized Chelsea Distributor.

MACK TRANSMISSION INDEX

Transmission Make and Model	PTO Appl. Number	Number Forward Speeds	Teeth in PTO Driver
TMD13AO (MDrive) High Split Range	MAK-35H	13	CS
TMD13AO (MDrive) Low Ratio	MAK-35	13	CS
TMD14AFO-HD (MDrive) High Split Range	MAK-35H	14	CS
TMD14AFO-HD (MDrive) Low Ratio	MAK-35	14	CS
TMD14AO (MDrive) High Split Range	MAK-35H	14	CS
TMD14AO (MDrive) Low Ratio	MAK-35	14	CS
TR720-7220	MAK-17	5	L38-R38
TRD7250	MAK-17	10	L38-R38
TRDL107	MAK-18	10	L37-R37
TRDL1070	MAK-19	10	L37-R37
TRDL720-7220	MAK-17	10	L38-R38
TRDLG1070	MAK-19	7	L37-R37
TRDX720-7220	MAK-17	10	L38-R38
TRDXL107	MAK-16	6	L34-R34
TRDXL1070	MAK-16	6	L34-R34
TRDXL1071	MAK-16	6	L34-R34
TRDXL1078	MAK-16	6	L34-R34
TRDXL10780	MAK-16	6	L34-R34
TRDXL10781	MAK-16	6	L34-R34
TRDXT720-7220	MAK-17	10	L38-R38
TRL107	MAK-22	5	L34-R34
TRL1076	MAK-16	5	L34-R34
TRL10760	MAK-20	5	L34-R34
TRL1078	MAK-16	5	L34-R34
TRL10780	MAK-20	5	L34-R34
TRQL7220	MAK-17	20	L38-R38
TRT720-7220	MAK-17	15	L38-R38
TRTL720-7220	MAK-17	15	L38-R38
TRTXL107	MAK-18	12	L37-R37
TRTXL1070	MAK-19	12	L37-R37
TRTXL1070-B	MAK-19	12	L37-R37
TRXL107	MAK-18	6	L37-R37
TRXL1070	MAK-21	6	L37-R37
TRXL1070-A	MAK-21	6	L37-R37
TRXL1071	MAK-18	6	L37-R37
TRXL10710	MAK-21	6	L37-R37

Mack



IMPORTANT: See Safety Information
in Section 1 of the Chelsea Applications
catalog HY25-3000/US

Transmission PTO Driver & Apertures (Viewed from Rear of Transmission)
L-Left Side R-Right Side B-Bottom Side T-Top Side CS-Countershaft
For transmissions not listed, contact your authorized Chelsea Distributor.

Transmission Make and Model	PTO Appl. Number	Number Forward Speeds	Teeth in PTO Driver
TRXL1071-A	MAK-18	6	L37-R37
TRXL1076	MAK-16	6	L34-R34
TRXL107-A	MAK-18	6	L37-R37
TX2060	MAK-25	7	L54-R54
X107	MAK-18	5	L37-R37
X1070	MAK-21	6	L37-R37
X1070-A	MAK-21	6	L37-R37
X1071	MAK-18	5	L37-R37
X10710	MAK-21	6	L37-R37
X10710-A	MAK-21	6	L37-R37
X1071-A	MAK-18	6	L37-R37
X107-A	MAK-18	6	L37-R37
X2060	MAK-25	7	L54-R54



IMPORTANT: See Safety Information in Section 1 of the Chelsea Applications catalog HY25-3000/US

Transmission PTO Driver & Apertures (Viewed from Rear of Transmission)
L-Left Side R-Right Side B-Bottom Side T-Top Side CS-Countershaft
For transmissions not listed, contact your authorized Chelsea Distributor.

MAK-16

MACK

CHELSEA®

DX1070 DX1071 DX1078 DX10780 DX10781 TRDXL107 TRDXL1070 TRDXL1071	TRDXL1078 TRDXL10780 TRDXL10781 TRL1076 TRL1078 TRXL1076
--	---

LEFT SIDE ONLY	RIGHT SIDE ONLY
TRANSMISSION GEAR DATA: L.S. 08-BOLT Opening Gear FORWARD of Centerline 34 Teeth - SPUR PITCH LINE TO APERTURE FACE: 0.8050" (20.4500MM)	TRANSMISSION GEAR DATA: R.S. 06-BOLT Opening Gear FORWARD of Centerline 34 Teeth - SPUR PITCH LINE TO APERTURE FACE: 3.0850" (78.3600MM)

CAUTION: Application Approval Required for PTO Output Shaft Speeds Above 2500 RPM

PTO Model	Torq I / C †	Dir Rot	Engine %		Filler Block	Adapter Assy	Stud Kit	PTO Model	Torq I / C †	Dir Rot	Engine %		Filler Block	Adapter Assy	Stud Kit
			Fwd	Rev							Fwd	Rev			

ONE SPEED - TWO GEAR - MECHANICAL SHIFT

221ZCAHX-*5	250 I	Opp	32		7-A-032(46)	328564X	Furnished	221XCAHX-*3	250 I	Eng	32		7-A-032(46)	328530-1X	328170-83X
221ZEAHX-*5	250 I	Opp	37			328564X	Furnished	221XEAHX-*3	250 I	Eng	37			328530-1X	328170-83X
489XAAHX-*5 (12)	250 I	Opp	28				Furnished	442KFAHX-*3 (2)	250 I	Eng	45			328530-1X	7170-16X
489XCAHX-*5 (13)	250 I	Opp	36				Furnished	442KHAHX-*3 (15)	250 I	Eng	52			328530-1X	7170-16X
489XFAHX-*5 (2)	250 I	Opp	45				Furnished	442KLAHX-*3 (1)	250 I	Eng	58			328530-1X	7170-16X
489XHAHX-*5 (15)	250 I	Opp	52				Furnished	442KQAHX-*3 (1)	225 I	Eng	62			328530-1X	7170-16X
489XLAHX-*5 (1)	250 I	Opp	58				Furnished	442KRAHX-*3 (1)	225 I	Eng	72			328530-1X	7170-16X
489XQAHX-*5 (1)	225 I	Opp	62				Furnished	442KSAHX-*3 (1)	200 I	Eng	86			328530-1X	7170-16X
489XRAHX-*5 (1)	225 I	Opp	72				Furnished	442KUAHX-*3 (1)	195 I	Eng	102			328530-1X	7170-16X
489XSAHX-*5 (1)	200 I	Opp	86				Furnished	442KWAHX-*3 (1)	175 I	Eng	121			328530-1X	7170-16X
489XUAHX-*5 (1)	195 I	Opp	102				Furnished	442KXAHX-*3 (1)	140 I	Eng	143			328530-1X	7170-16X
489XWAHX-*5 (1)	175 I	Opp	121				Furnished	660KHAHX-*3 (15)	375 I	Eng	52			328530-1X	7170-16X
489XAXHX-*5 (1)	140 I	Opp	143				Furnished								
680XFAHX-*5 (10)	375 I	Opp	45				Furnished								
680XHAHX-*5 (19)	375 I	Opp	52				Furnished								
680XQAHX-*5 (11)	375 I	Opp	62				Furnished								
680XRAHX-*5 (18)	350 I	Opp	72				Furnished								
680XSAHX-*5 (14)	325 I	Opp	86				Furnished								
823XBAHX-*3 (39)	500 I	Opp	30				Furnished								
823XDAHX-*3 (43)	500 I	Opp	36				Furnished								
823XGAHX-*3 (44)	500 I	Opp	36				Furnished								
823XJAHX-*3 (40)	500 I	Opp	46				Furnished								
823XMAHX-*3 (38)	500 I	Opp	54				Furnished								
823XRAHX-*3 (42)	400 I	Opp	75				Furnished								
823XTKTX-*3 (17)	372 I	Opp	90		8-A-165		7170-116X								
880XBAHX-*3 (3)	500 I	Opp	30				Furnished								
880XDAHX-*3 (4)	500 I	Opp	36				Furnished								
880XGAHX-*3 (9)	500 I	Opp	39				Furnished								
880XJAHX-*3 (5)	500 I	Opp	46				Furnished								
880XMAHX-*3 (6)	500 I	Opp	54				Furnished								
880XQAHX-*3 (16)	450 I	Opp	64				Furnished								

† I = Intermittent Torque Only - De-rate Torque Rating 30% for Continuous Duty.

C = Continuous or Intermittent Torque - No need to De-Rate Torque Rating.

IMPORTANT: Refer to the back of this transmission section and read all notes associated with this application page. Some notes may affect the proper PTO selection.

CAUTION: Do not use geared adapters with 442 A and C ratios.

- (1) Input Gear Part No. 5-P-1004
- (2) Input Gear Part No. 5-P-1077
- (3) Input Gear Part No. 5-P-1100
- (4) Input Gear Part No. 5-P-1101
- (5) Input Gear Part No. 5-P-1102
- (6) Input Gear Part No. 5-P-1103

- (9) Input Gear Part No. 5-P-1135
- (10) Input Gear Part No. 5-P-1242
- (11) Input Gear Part No. 5-P-1246
- (12) Input Gear Part No. 5-P-1280
- (13) Input Gear Part No. 5-P-1287
- (14) Input Gear Part No. 5-P-1322

- (15) Input Gear Part No. 5-P-1364
- (16) Input Gear Part No. 5-P-1385
- (17) Input Gear Part No. 5-P-1395
- (18) Input Gear Part No. 5-P-1441
- (19) Input Gear Part No. 5-P-1494
- (38) Input Gear Part No. 5-P-283

- (39) Input Gear Part No. 5-P-285
- (40) Input Gear Part No. 5-P-325
- (42) Input Gear Part No. 5-P-721
- (43) Input Gear Part No. 5-P-971
- (44) Input Gear Part No. 5-P-980
- (46) Furnished, but not required

DX1070 DX1071 DX1078 DX10780 DX10781 TRDXL107 TRDXL1070 TRDXL1071	TRDXL1078 TRDXL10780 TRDXL10781 TRL1076 TRL1078 TRXL1076
--	---

LEFT SIDE ONLY	RIGHT SIDE ONLY
TRANSMISSION GEAR DATA: L.S. 08-BOLT Opening Gear FORWARD of Centerline 34 Teeth - SPUR PITCH LINE TO APERTURE FACE: 0.8050" (20.4500MM)	TRANSMISSION GEAR DATA: R.S. 06-BOLT Opening Gear FORWARD of Centerline 34 Teeth - SPUR PITCH LINE TO APERTURE FACE: 3.0850" (78.3600MM)

CAUTION: Application Approval Required for PTO Output Shaft Speeds Above 2500 RPM

PTO Model	Torq I / C †	Dir Rot	Engine %		Filler Block	Adapter Assy	Stud Kit	PTO Model	Torq I / C †	Dir Rot	Engine %		Filler Block	Adapter Assy	Stud Kit
			Fwd	Rev							Fwd	Rev			

ONE SPEED - TWO GEAR - MECHANICAL SHIFT

880XRAHX-*3 (7)	400 I	Opp	75				Furnished								
880XTAHX-*3 (8)	350 I	Opp	96				Furnished								

ONE SPEED - TWO GEAR POWERSHIFT (AIR OR HYDRAULIC)

282XBAJX-*5 (20)	300 C	Opp	31		8-A-032		Furnished	272KAAJX-*3 (29)	300 C	Eng	25			328530-1X	7170-16X
282XCAJX-*5 (21)	300 C	Opp	37		8-A-032		Furnished	272KBAJX-*3 (30)	300 C	Eng	31			328530-1X	7170-16X
282XDAJX-*5 (22)	300 C	Opp	44		8-A-032		Furnished	272KCAJX-*3 (31)	300 C	Eng	37			328530-1X	7170-16X
282XGAJX-*5 (23)	300 C	Opp	52		8-A-032		Furnished	272KDAJX-*3 (32)	300 C	Eng	42			328530-1X	7170-16X
282XKAJX-*5 (24)	300 C	Opp	59		8-A-032		Furnished	272KGAJX-*3 (33)	300 C	Eng	52			328530-1X	7170-16X
282XMAJX-*5 (25)	300 C	Opp	66		8-A-032		Furnished	272KKAJX-*3 (34)	300 C	Eng	59			328530-1X	7170-16X
282XPAJX-*5 (26)	300 C	Opp	73		8-A-032		Furnished	272KMAJX-*3 (35)	300 C	Eng	66			328530-1X	7170-16X
282XSAJX-*5 (27)	300 C	Opp	82		8-A-032		Furnished	272KPAJX-*3 (36)	300 C	Eng	73			328530-1X	7170-16X
282XTAJX-*5 (28)	300 C	Opp	92		8-A-032		Furnished	272KSAJX-*3 (37)	300 C	Eng	82			328530-1X	7170-16X

ONE SPEED - TWO GEAR - POWERSHIFT (AIR)

885XBAHX-*3 (3)	500 I	Opp	30				Furnished								
885XGAHX-*3 (9)	500 I	Opp	39				Furnished								
885XJAHX-*3 (5)	500 I	Opp	46				Furnished								
885XMAHX-*3 (6)	500 I	Opp	54				Furnished								

ONE SPEED - FORWARD & REVERSE

348ZFAHX-*5 (41)	200 I	Opp	39	41	8-A-093(T) 8-A-032(P)		Furnished	340XFAHX-*5 (41)	200 I	Eng	39	41	7-A-140(P)(45)	328530-1X	7170-16X
863XBAHX-*5	500 I	Opp	30	38			Furnished								

GEARED ADAPTERS

628XAHX-3AH	250 I	Eng					Furnished								
-------------	-------	-----	--	--	--	--	-----------	--	--	--	--	--	--	--	--

† I = Intermittent Torque Only - De-rate Torque Rating 30% for Continuous Duty.

C = Continuous or Intermittent Torque - No need to De-Rate Torque Rating.

IMPORTANT: Refer to the back of this transmission section and read all notes associated with this application page. Some notes may affect the proper PTO selection.

CAUTION: Do not use geared adapters with 442 A and C ratios.

- (3) Input Gear Part No. 5-P-1100
- (5) Input Gear Part No. 5-P-1102
- (6) Input Gear Part No. 5-P-1103
- (7) Input Gear Part No. 5-P-1104
- (8) Input Gear Part No. 5-P-1105
- (9) Input Gear Part No. 5-P-1135

- (20) Input Gear Part No. 5-P-1510-11X
- (21) Input Gear Part No. 5-P-1510-12X
- (22) Input Gear Part No. 5-P-1510-13X
- (23) Input Gear Part No. 5-P-1510-14X
- (24) Input Gear Part No. 5-P-1510-15X
- (25) Input Gear Part No. 5-P-1510-16X

- (26) Input Gear Part No. 5-P-1510-17X
- (27) Input Gear Part No. 5-P-1510-18X
- (28) Input Gear Part No. 5-P-1510-19X
- (29) Input Gear Part No. 5-P-1510-1X
- (30) Input Gear Part No. 5-P-1510-2X
- (31) Input Gear Part No. 5-P-1510-3X

- (32) Input Gear Part No. 5-P-1510-4X
- (33) Input Gear Part No. 5-P-1510-5X
- (34) Input Gear Part No. 5-P-1510-6X
- (35) Input Gear Part No. 5-P-1510-7X
- (36) Input Gear Part No. 5-P-1510-8X
- (37) Input Gear Part No. 5-P-1510-9X

- (41) Input Gear Part No. 5-P-581
- (45) Filler block furnished with PTO

MAK-17

MACK

CHELSEA®

QL7220 TRDL720-7220 TRDXT720-7220 TRDX720-7220 TRD7250 TRQL7220 TRTL720-7220 TRT720-7220	TR720-7220
---	------------

LEFT SIDE ONLY	RIGHT SIDE ONLY
TRANSMISSION GEAR DATA: L.S. 06-BOLT Opening Gear REAR of Centerline 38 Teeth - SPUR PITCH LINE TO APERTURE FACE: 3.0500" (77.4700MM)	TRANSMISSION GEAR DATA: R.S. 06-BOLT Opening Gear REAR of Centerline 38 Teeth - SPUR PITCH LINE TO APERTURE FACE: 3.0500" (77.4700MM)

CAUTION: Application Approval Required for PTO Output Shaft Speeds Above 2500 RPM

PTO Model	Torq I / C †	Dir Rot	Engine %		Filler Block	Adapter Assy	Stud Kit	PTO Model	Torq I / C †	Dir Rot	Engine %		Filler Block	Adapter Assy	Stud Kit
			Fwd	Rev							Fwd	Rev			
ONE SPEED - TWO GEAR - MECHANICAL SHIFT															
442KFABX-*6 (2)	250 I	Eng	75		7-A-032(T)	328530-2X	7170-16X	442KFABX-*4 (2)	250 I	Eng	75		7-A-032(T)	328530-2X	7170-16X
442KLABX-*6 (1)	250 I	Eng	97		7-A-032(T)	328530-2X	7170-16X	442KLABX-*4 (1)	250 I	Eng	97		7-A-032(T)	328530-2X	7170-16X
442KQABX-*6 (1)	225 I	Eng	104		7-A-032(T)	328530-2X	7170-16X	442KQABX-*4 (1)	225 I	Eng	104		7-A-032(T)	328530-2X	7170-16X
442KRABX-*6 (1)	225 I	Eng	121		7-A-032(T)	328530-2X	7170-16X	442KRABX-*4 (1)	225 I	Eng	121		7-A-032(T)	328530-2X	7170-16X
442KSABX-*6 (1)	200 I	Eng	144		7-A-032(T)	328530-2X	7170-16X	442KSABX-*4 (1)	200 I	Eng	144		7-A-032(T)	328530-2X	7170-16X
442KUABX-*6 (1)	195 I	Eng	172		7-A-032(T)	328530-2X	7170-16X	442KUABX-*4 (1)	195 I	Eng	172		7-A-032(T)	328530-2X	7170-16X
442KWABX-*6 (1)	175 I	Eng	202		7-A-032(T)	328530-2X	7170-16X	442KWABX-*4 (1)	175 I	Eng	202		7-A-032(T)	328530-2X	7170-16X
442KXABX-*6 (1)	140 I	Eng	239		7-A-032(T)	328530-2X	7170-16X	442KXABX-*4 (1)	140 I	Eng	239		7-A-032(T)	328530-2X	7170-16X

ONE SPEED - FORWARD & REVERSE															
340XFABX-*4 (3)	200 I	Eng	68	72	7-A-140(P)(4) 7-A-032(T)	328530-2X	7170-16X	340XFABX-*4 (3)	200 I	Eng	68	72	7-A-140(P)(4) 7-A-032(T)	328530-2X	7170-16X

† I = Intermittent Torque Only - De-rate Torque Rating 30% for Continuous Duty.

C = Continuous or Intermittent Torque - No need to De-Rate Torque Rating.

IMPORTANT: Refer to the back of this transmission section and read all notes associated with this application page. Some notes may affect the proper PTO selection.

Mack

(1) Input Gear Part No. 5-P-1001
 (2) Input Gear Part No. 5-P-1076
 (3) Input Gear Part No. 5-P-579
 (4) Filler block furnished with PTO

D107 X107
TRDL107 X107-A
TRXL107 X1071
TRXL107 X1071-A
TRXL1071
TRXL1071-A
T107

LEFT SIDE ONLY

RIGHT SIDE ONLY

TRANSMISSION GEAR DATA:
L.S. 08-BOLT Opening Gear FORWARD of Centerline
37 Teeth - SPUR
PITCH LINE TO APERTURE FACE:
0.5700" (14.4800MM)

TRANSMISSION GEAR DATA:
R.S. 06-BOLT Opening Gear FORWARD of Centerline
37 Teeth - SPUR
PITCH LINE TO APERTURE FACE:
2.8340" (71.9800MM)

CAUTION: Application Approval Required for PTO Output Shaft Speeds Above 2500 RPM

PTO Model	Torq I / C †	Dir Rot	Engine %		Filler Block	Adapter Assy	Stud Kit	PTO Model	Torq I / C †	Dir Rot	Engine %		Filler Block	Adapter Assy	Stud Kit
			Fwd	Rev							Fwd	Rev			

ONE SPEED - TWO GEAR - MECHANICAL SHIFT

489KAAHX-*5 (12)	250 I	Opp	64		8-A-062 8-A-093		328170-8X	442KFAHX-*3 (2)	250 I	Eng	101		7-A-240(T)	328530-1X	328170-168X
489KCAHX-*5 (13)	250 I	Opp	81		8-A-062 8-A-093		328170-8X	442KHAHX-*3 (15)	250 I	Eng	117		7-A-240(T)	328530-1X	328170-168X
489KFAHX-*5 (2)	250 I	Opp	101		8-A-062 8-A-093		328170-8X	442KLAHX-*3 (1)	250 I	Eng	130		7-A-240(T)	328530-1X	328170-168X
489KHAHX-*5 (15)	250 I	Opp	117		8-A-062 8-A-093		328170-8X	442KQAHX-*3 (1)	225 I	Eng	140		7-A-240(T)	328530-1X	328170-168X
489KLAHX-*5 (1)	250 I	Opp	130		8-A-062 8-A-093		328170-8X	442KRAHX-*3 (1)	225 I	Eng	162		7-A-240(T)	328530-1X	328170-168X
489KQAHX-*5 (1)	225 I	Opp	140		8-A-062 8-A-093		328170-8X	442KSAHX-*3 (1)	200 I	Eng	193		7-A-240(T)	328530-1X	328170-168X
489KRAHX-*5 (1)	225 I	Opp	162		8-A-062 8-A-093		328170-8X	442KUAHX-*3 (1)	195 I	Eng	230		7-A-240(T)	328530-1X	328170-168X
489KSAHX-*5 (1)	200 I	Opp	193		8-A-062 8-A-093		328170-8X	442KWAHX-*3 (1)	175 I	Eng	271		7-A-240(T)	328530-1X	328170-168X
489KUAHX-*5 (1)	195 I	Opp	230		8-A-062 8-A-093		328170-8X	442KXAHX-*3 (1)	140 I	Eng	321		7-A-240(T)	328530-1X	328170-168X
489KWAHX-*5 (1)	175 I	Opp	271		8-A-062 8-A-093		328170-8X	660KHAHX-*3 (15)	375 I	Eng	117		7-A-240(T)	328530-1X	328170-168X
489KXAHX-*5 (1)	140 I	Opp	321		8-A-062 8-A-093		328170-8X								
680KFAHX-*5 (10)	375 I	Opp	101		8-A-062 8-A-093		328170-8X								
680KHAHX-*5 (18)	375 I	Opp	117		8-A-062 8-A-093		328170-8X								
680KQAHX-*5 (11)	375 I	Opp	140		8-A-062 8-A-093		328170-8X								
680KRAHX-*5 (17)	350 I	Opp	162		8-A-062 8-A-093		328170-8X								
680KSAHX-*5 (14)	325 I	Opp	193		8-A-062 8-A-093		328170-8X								

† I = Intermittent Torque Only - De-rate Torque Rating 30% for Continuous Duty.

C = Continuous or Intermittent Torque - No need to De-Rate Torque Rating.

IMPORTANT: Refer to the back of this transmission section and read all notes associated with this application page. Some notes may affect the proper PTO selection.

CAUTION: Do not use geared adapters with 442 A and C ratios.

(1) Input Gear Part No. 5-P-1004
(2) Input Gear Part No. 5-P-1077
(10) Input Gear Part No. 5-P-1242
(11) Input Gear Part No. 5-P-1246
(12) Input Gear Part No. 5-P-1280
(13) Input Gear Part No. 5-P-1287

(14) Input Gear Part No. 5-P-1322
(15) Input Gear Part No. 5-P-1364
(17) Input Gear Part No. 5-P-1441
(18) Input Gear Part No. 5-P-1494

MAK-18

MACK

CHELSEA®

D107	X107
TRDL107	X107-A
TRTXL107	X1071
TRXL107	X1071-A
TRXL107-A	
TRXL1071	
TRXL1071-A	
T107	

LEFT SIDE ONLY

RIGHT SIDE ONLY

TRANSMISSION GEAR DATA:

L.S. 08-BOLT Opening Gear FORWARD of Centerline
37 Teeth - SPUR

PITCH LINE TO APERTURE FACE:
0.5700" (14.4800MM)

TRANSMISSION GEAR DATA:

R.S. 06-BOLT Opening Gear FORWARD of Centerline
37 Teeth - SPUR

PITCH LINE TO APERTURE FACE:
2.8340" (71.9800MM)

CAUTION: Application Approval Required for PTO Output Shaft Speeds Above 2500 RPM

PTO Model	Torq I / C †	Dir Rot	Engine %		Filler Block	Adapter Assy	Stud Kit	PTO Model	Torq I / C †	Dir Rot	Engine %		Filler Block	Adapter Assy	Stud Kit
			Fwd	Rev							Fwd	Rev			

ONE SPEED - TWO GEAR - MECHANICAL SHIFT

823XBAHX-*5 (38)	500 I	Opp	69	8-A-190	328170-14X
823XDAHX-*5 (42)	500 I	Opp	81	8-A-190	328170-14X
823XGAHX-*5 (43)	500 I	Opp	88	8-A-190	328170-14X
823XJAHX-*5 (39)	500 I	Opp	104	8-A-190	328170-14X
823XMAHX-*5 (37)	500 I	Opp	122	8-A-190	328170-14X
823XRAHX-*5 (41)	400 I	Opp	168	8-A-190	328170-14X
880KBAHX-*5 (3)	500 I	Opp	69	8-A-190	328170-14X
880KDAHX-*5 (4)	500 I	Opp	81	8-A-190	328170-14X
880KGAHX-*5 (9)	500 I	Opp	88	8-A-190	328170-14X
880KJAHX-*5 (5)	500 I	Opp	104	8-A-190	328170-14X
880KMAHX-*5 (6)	500 I	Opp	122	8-A-190	328170-14X
880KQAHX-*5 (16)	450 I	Opp	142	8-A-190	328170-14X
880KRAHX-*5 (7)	400 I	Opp	168	8-A-190	328170-14X
880KTAHX-*5 (8)	350 I	Opp	217	8-A-190	328170-14X

ONE SPEED - TWO GEAR POWERSHIFT (AIR OR HYDRAULIC)

282KBAJX-*5 (19)	300 C	Opp	69	8-A-093(P) 8-A-032(T)	328170-8X	272KAAJX-*3 (28)	300 C	Eng	56	7-A-240(T)	328530-1X	328170-168X
282KCAJX-*5 (20)	300 C	Opp	83	8-A-093(P) 8-A-032(T)	328170-8X	272KBAJX-*3 (29)	300 C	Eng	69	7-A-240(T)	328530-1X	328170-168X
282KDAJX-*5 (21)	300 C	Opp	99	8-A-093(P) 8-A-032(T)	328170-8X	272KCAJX-*3 (30)	300 C	Eng	83	7-A-240(T)	328530-1X	328170-168X
282KGAJX-*5 (22)	300 C	Opp	118	8-A-093(P) 8-A-032(T)	328170-8X	272KDAJX-*3 (31)	300 C	Eng	94	7-A-240(T)	328530-1X	328170-168X
282KKAJX-*5 (23)	300 C	Opp	132	8-A-093(P) 8-A-032(T)	328170-8X	272KGAJX-*3 (32)	300 C	Eng	118	7-A-240(T)	328530-1X	328170-8X
282KMAJX-*5 (24)	300 C	Opp	148	8-A-093(P) 8-A-032(T)	328170-8X	272KKAJX-*3 (33)	300 C	Eng	132	7-A-240(T)	328530-1X	328170-8X
282KPAJX-*5 (25)	300 C	Opp	165	8-A-093(P) 8-A-032(T)	328170-8X	2272KMAJX-*3 (34)	300 C	Eng	148	7-A-240(T)	328530-1X	328170-8X

† I = Intermittent Torque Only - De-rate Torque Rating 30% for Continuous Duty.

C = Continuous or Intermittent Torque - No need to De-Rate Torque Rating.

IMPORTANT: Refer to the back of this transmission section and read all notes associated with this application page. Some notes may affect the proper PTO selection.

CAUTION: Do not use geared adapters with 442 A and C ratios.

- (3) Input Gear Part No. 5-P-1100
- (4) Input Gear Part No. 5-P-1101
- (5) Input Gear Part No. 5-P-1102
- (6) Input Gear Part No. 5-P-1103
- (7) Input Gear Part No. 5-P-1104
- (8) Input Gear Part No. 5-P-1105

- (9) Input Gear Part No. 5-P-1135
- (16) Input Gear Part No. 5-P-1385
- (19) Input Gear Part No. 5-P-1510-11X
- (20) Input Gear Part No. 5-P-1510-12X
- (21) Input Gear Part No. 5-P-1510-13X
- (22) Input Gear Part No. 5-P-1510-14X

- (23) Input Gear Part No. 5-P-1510-15X
- (24) Input Gear Part No. 5-P-1510-16X
- (25) Input Gear Part No. 5-P-1510-17X
- (28) Input Gear Part No. 5-P-1510-1X
- (29) Input Gear Part No. 5-P-1510-2X
- (30) Input Gear Part No. 5-P-1510-3X

- (31) Input Gear Part No. 5-P-1510-4X
- (32) Input Gear Part No. 5-P-1510-5X
- (33) Input Gear Part No. 5-P-1510-6X
- (34) Input Gear Part No. 5-P-1510-7X
- (37) Input Gear Part No. 5-P-283
- (38) Input Gear Part No. 5-P-285

- (39) Input Gear Part No. 5-P-325
- (41) Input Gear Part No. 5-P-721
- (42) Input Gear Part No. 5-P-971
- (43) Input Gear Part No. 5-P-980

CHELSEA®

MACK

MAK-18

D107
TRDL107
TRXL107
TRXL107
TRXL107-A
TRXL1071
TRXL1071-A
T107X107
X107-A
X1071
X1071-A

LEFT SIDE ONLY

RIGHT SIDE ONLY

TRANSMISSION GEAR DATA:

L.S. 08-BOLT Opening Gear FORWARD of Centerline
37 Teeth - SPUR

PITCH LINE TO APERTURE FACE:

0.5700" (14.4800MM)

TRANSMISSION GEAR DATA:

R.S. 06-BOLT Opening Gear FORWARD of Centerline
37 Teeth - SPUR

PITCH LINE TO APERTURE FACE:

2.8340" (71.9800MM)

CAUTION: Application Approval Required for PTO Output Shaft Speeds Above 2500 RPM

PTO Model	Torq I / C †	Dir Rot	Engine %		Filler Block	Adapter Assy	Stud Kit	PTO Model	Torq I / C †	Dir Rot	Engine %		Filler Block	Adapter Assy	Stud Kit
			Fwd	Rev							Fwd	Rev			
ONE SPEED - TWO GEAR POWERSHIFT (AIR OR HYDRAULIC)															
282KSAJX-*5 (26)	271 C	Opp	184		8-A-093(P) 8-A-032(T)		328170-8X	272KPAJX-*3 (35)	300 C	Eng	165		7-A-240(T)	328530-1X	328170-168X
282KTAJX-*5 (27)	242 C	Opp	206		8-A-093(P) 8-A-032(T)		328170-8X	272KSAJX-*3 (36)	271 C	Eng	184		7-A-240(T)	328530-1X	328170-168X
ONE SPEED - TWO GEAR - POWERSHIFT (AIR)															
885XBAHX-*5 (3)	500 I	Opp	69		8-A-190		328170-14X								
885XGAHX-*5 (9)	500 I	Opp	88		8-A-190		328170-14X								
885XJAHX-*5 (5)	500 I	Opp	104		8-A-190		328170-14X								
885XMAHX-*5 (6)	500 I	Opp	122		8-A-190		328170-14X								
ONE SPEED - FORWARD & REVERSE															
348XFAHX-*5 (40)	200 I	Opp	88	92	8-A-190(T)		328170-8X	340XFAHX-*5 (40)	200 I	Eng	88	92	7-A-140(P)(44)	328530-1X	328170-168X 7-A-240(T)
863XBAHX-*5	500 I	Opp	69	85	8-A-190		328170-15X								
GEARED ADAPTERS															
628XAHX-3AH	250 I	Eng			8-A-190		328170-8X								

† I = Intermittent Torque Only - De-rate Torque Rating 30% for Continuous Duty.

C = Continuous or Intermittent Torque - No need to De-Rate Torque Rating.

IMPORTANT: Refer to the back of this transmission section and read all notes associated with this application page.
Some notes may affect the proper PTO selection.

CAUTION: Do not use geared adapters with 442 A and C ratios.

(3) Input Gear Part No. 5-P-1100
(5) Input Gear Part No. 5-P-1102
(6) Input Gear Part No. 5-P-1103
(9) Input Gear Part No. 5-P-1135
(26) Input Gear Part No. 5-P-1510-18X
(27) Input Gear Part No. 5-P-1510-19X

(35) Input Gear Part No. 5-P-1510-8X
(36) Input Gear Part No. 5-P-1510-9X
(40) Input Gear Part No. 5-P-581
(44) Filler block furnished with PTO

MAK-19

MACK

CHELSEA®

D1070
G1070
TRDLG1070
TRDL1070
TRTXL1070
TRTXL1070-B
T1070
T1070-B

LEFT SIDE ONLY

RIGHT SIDE ONLY

TRANSMISSION GEAR DATA:

L.S. 08-BOLT Opening Gear REAR of Centerline
37 Teeth - SPUR

PITCH LINE TO APERTURE FACE:
0.3750" (9.5200MM)

TRANSMISSION GEAR DATA:

R.S. 06-BOLT Opening Gear REAR of Centerline
37 Teeth - SPUR

PITCH LINE TO APERTURE FACE:
2.8340" (71.9800MM)

CAUTION: Application Approval Required for PTO Output Shaft Speeds Above 2500 RPM

PTO Model	Torq l / C †	Dir Rot	Engine %		Filler Block	Adapter Assy	Stud Kit	PTO Model	Torq l / C †	Dir Rot	Engine %		Filler Block	Adapter Assy	Stud Kit
			Fwd	Rev							Fwd	Rev			
ONE SPEED - TWO GEAR - MECHANICAL SHIFT															
489KFAHX-*6 (2)	250 l	Opp	129		8-A-062 8-A-093		328170-8X	442KFAHX-*4 (2)	250 l	Eng	129		7-A-240(T)	328530-1X	328170-168X
489KHAHX-*6 (13)	250 l	Opp	150		8-A-062 8-A-093		328170-8X	442KHAHX-*4 (13)	250 l	Eng	150		7-A-240(T)	328530-1X	328170-168X
489KLAHX-*6 (1)	250 l	Opp	168		8-A-062 8-A-093		328170-8X	442KLAHX-*4 (1)	250 l	Eng	168		7-A-240(T)	328530-1X	328170-168X
489KQAHX-*6 (1)	225 l	Opp	180		8-A-062 8-A-093		328170-8X	442KQAHX-*4 (1)	225 l	Eng	180		7-A-240(T)	328530-1X	328170-168X
489KRAHX-*6 (1)	225 l	Opp	209		8-A-062 8-A-093		328170-8X	442KRAHX-*4 (1)	225 l	Eng	209		7-A-240(T)	328530-1X	328170-168X
489KSAHX-*6 (1)	200 l	Opp	249		8-A-062 8-A-093		328170-8X	442KSAHX-*4 (1)	200 l	Eng	249		7-A-240(T)	328530-1X	328170-168X
489KUAHX-*6 (1)	195 l	Opp	296		8-A-062 8-A-093		328170-8X	442KUAHX-*4 (1)	195 l	Eng	296		7-A-240(T)	328530-1X	328170-168X
489KWAHX-*6 (1)	175 l	Opp	349		8-A-062 8-A-093		328170-8X	442KWAHX-*4 (1)	175 l	Eng	349		7-A-240(T)	328530-1X	328170-168X
489KXAHX-*6 (1)	140 l	Opp	412		8-A-062 8-A-093		328170-8X	442KXAHX-*4 (1)	140 l	Eng	412		7-A-240(T)	328530-1X	328170-168X
680KHAHX-*6 (16)	375 l	Opp	150		8-A-062 8-A-093		328170-8X	660KHAHX-*4 (13)	375 l	Eng	150		7-A-240(T)	328530-1X	328170-168X
680XFAHX-*6 (10)	375 l	Opp	129		8-A-062 8-A-093		328170-8X								
680XQAHX-*6 (11)	375 l	Opp	180		8-A-062 8-A-093		328170-8X								
680XRAHX-*6 (15)	350 l	Opp	209		8-A-062 8-A-093		328170-8X								
680XSAHX-*6 (12)	325 l	Opp	249		8-A-062 8-A-093		328170-8X								
823XBAHX-*6 (18)	500 l	Opp	88		8-A-190		328170-14X								
823XDAHX-*6 (22)	500 l	Opp	104		8-A-190		328170-14X								
823XGAHX-*6 (23)	500 l	Opp	113		8-A-190		328170-14X								
823XJAHX-*6 (19)	500 l	Opp	133		8-A-190		328170-14X								

† I = Intermittent Torque Only - De-rate Torque Rating 30% for Continuous Duty.

C = Continuous or Intermittent Torque - No need to De-Rate Torque Rating.

IMPORTANT: Refer to the back of this transmission section and read all notes associated with this application page. Some notes may affect the proper PTO selection.

CAUTION: Do not use geared adapters with 442 A and C ratios.

- (1) Input Gear Part No. 5-P-1004
- (2) Input Gear Part No. 5-P-1077
- (10) Input Gear Part No. 5-P-1242
- (11) Input Gear Part No. 5-P-1246
- (12) Input Gear Part No. 5-P-1322
- (13) Input Gear Part No. 5-P-1364

- (15) Input Gear Part No. 5-P-1441
- (16) Input Gear Part No. 5-P-1494
- (18) Input Gear Part No. 5-P-285
- (19) Input Gear Part No. 5-P-325
- (22) Input Gear Part No. 5-P-971
- (23) Input Gear Part No. 5-P-980

D1070
G1070
TRDLG1070
TRDL1070
TRTXL1070
TRTXL1070-B
T1070
T1070-B

LEFT SIDE ONLY

RIGHT SIDE ONLY

TRANSMISSION GEAR DATA:

L.S. 08-BOLT Opening Gear REAR of Centerline
37 Teeth - SPUR

PITCH LINE TO APERTURE FACE:
0.3750" (9.5200MM)

TRANSMISSION GEAR DATA:

R.S. 06-BOLT Opening Gear REAR of Centerline
37 Teeth - SPUR

PITCH LINE TO APERTURE FACE:
2.8340" (71.9800MM)

CAUTION: Application Approval Required for PTO Output Shaft Speeds Above 2500 RPM

PTO Model	Torq I / C †	Dir Rot	Engine %		Filler Block	Adapter Assy	Stud Kit	PTO Model	Torq I / C †	Dir Rot	Engine %		Filler Block	Adapter Assy	Stud Kit
			Fwd	Rev							Fwd	Rev			
ONE SPEED - TWO GEAR - MECHANICAL SHIFT															
823XMAHX-*6 (17)	500 I	Opp	157		8-A-190		328170-14X								
823XRAHX-*6 (21)	400 I	Opp	216		8-A-190		328170-14X								
880XBAHX-*6 (3)	500 I	Opp	88		8-A-190		328170-14X								
880XDAHX-*6 (4)	500 I	Opp	104		8-A-190		328170-14X								
880XGAHX-*6 (9)	500 I	Opp	113		8-A-190		328170-14X								
880XJAHX-*6 (5)	500 I	Opp	133		8-A-190		328170-14X								
880XMAHX-*6 (6)	500 I	Opp	157		8-A-190		328170-14X								
880XQAHX-*6 (14)	450 I	Opp	183		8-A-190		328170-14X								
880XRAHX-*6 (7)	400 I	Opp	216		8-A-190		328170-14X								
880XTAHX-*6 (8)	350 I	Opp	279		8-A-190		328170-14X								
ONE SPEED - TWO GEAR - POWERSHIFT (AIR)															
885XGAHX-*6 (9)	500 I	Opp	113		8-A-190		328170-14X								
885XJAHX-*6 (5)	500 I	Opp	133		8-A-190		328170-14X								
885XMAHX-*6 (6)	500 I	Opp	157		8-A-190		328170-14X								
ONE SPEED - FORWARD & REVERSE															
348XFAHX-*4 (20)	200 I	Opp	113	119	8-A-190(T)		328170-8X	340XFAHX-*4 (20)	200 I	Eng	113	119	7-A-140(P)(24)	328530-1X	328170-168X 7-A-240(T)
863XBAHX-*4	500 I	Opp	88	109	8-A-190		328170-15X								
GEARED ADAPTERS															
628XAHX-3AH	250 I	Eng			8-A-190		328170-8X								

† I = Intermittent Torque Only - De-rate Torque Rating 30% for Continuous Duty.

C = Continuous or Intermittent Torque - No need to De-Rate Torque Rating.

IMPORTANT: Refer to the back of this transmission section and read all notes associated with this application page. Some notes may affect the proper PTO selection.

CAUTION: Do not use geared adapters with 442 A and C ratios.

- (3) Input Gear Part No. 5-P-1100
- (4) Input Gear Part No. 5-P-1101
- (5) Input Gear Part No. 5-P-1102
- (6) Input Gear Part No. 5-P-1103
- (7) Input Gear Part No. 5-P-1104
- (8) Input Gear Part No. 5-P-1105

- (9) Input Gear Part No. 5-P-1135
- (14) Input Gear Part No. 5-P-1385
- (17) Input Gear Part No. 5-P-283
- (20) Input Gear Part No. 5-P-581
- (21) Input Gear Part No. 5-P-721
- (24) Filler block furnished with PTO

MAK-20

MACK

CHELSEA®

TRL 10760
TRL 10780

LEFT SIDE ONLY

RIGHT SIDE ONLY

TRANSMISSION GEAR DATA:

L.S. 08-BOLT Opening Gear FORWARD of Centerline
34 Teeth - SPUR

PITCH LINE TO APERTURE FACE:
0.8050" (20.4500MM)

TRANSMISSION GEAR DATA:

R.S. 06-BOLT Opening Gear FORWARD of Centerline
34 Teeth - SPUR

PITCH LINE TO APERTURE FACE:
3.0850" (78.3600MM)

CAUTION: Application Approval Required for PTO Output Shaft Speeds Above 2500 RPM

PTO Model	Torq I / C †	Dir Rot	Engine %		Filler Block	Adapter Assy	Stud Kit	PTO Model	Torq I / C †	Dir Rot	Engine %		Filler Block	Adapter Assy	Stud Kit
			Fwd	Rev							Fwd	Rev			

ONE SPEED - TWO GEAR - MECHANICAL SHIFT

489XAAHX-*5 (12)	250 I	Opp	46				Furnished	442KFAHX-*3 (2)	250 I	Eng	73				328530-1X	7170-16X
489XCAHX-*5 (13)	250 I	Opp	59				Furnished	442KHAHX-*3 (15)	250 I	Eng	85				328530-1X	7170-16X
489XFAHX-*5 (2)	250 I	Opp	73				Furnished	442KLAHX-*3 (1)	250 I	Eng	95				328530-1X	7170-16X
489XHAHX-*5 (15)	250 I	Opp	85				Furnished	442KQAHX-*3 (1)	225 I	Eng	102				328530-1X	7170-16X
489XLAHX-*5 (1)	250 I	Opp	95				Furnished	442KRAHX-*3 (1)	225 I	Eng	119				328530-1X	7170-16X
489XQAHX-*5 (1)	225 I	Opp	102				Furnished	442KSAHX-*3 (1)	200 I	Eng	141				328530-1X	7170-16X
489XRAHX-*5 (1)	225 I	Opp	119				Furnished	442KUAHX-*3 (1)	195 I	Eng	168				328530-1X	7170-16X
489XSAHX-*5 (1)	200 I	Opp	141				Furnished	442KWAHX-*3 (1)	175 I	Eng	198				328530-1X	7170-16X
489XUAHX-*5 (1)	195 I	Opp	168				Furnished	442KXAHX-*3 (1)	140 I	Eng	234				328530-1X	7170-16X
489XWAHX-*5 (1)	175 I	Opp	198				Furnished	660KHAHX-*3 (15)	375 I	Eng	85				328530-1X	7170-16X
489XXAHX-*5 (1)	140 I	Opp	234				Furnished									
680XFAHX-*5 (10)	375 I	Opp	73				Furnished									
680XHAHX-*5 (19)	375 I	Opp	85				Furnished									
680XQAHX-*5 (11)	375 I	Opp	102				Furnished									
680XRAHX-*5 (18)	350 I	Opp	119				Furnished									
680XSAHX-*5 (14)	325 I	Opp	141				Furnished									
823XBAHX-*3 (39)	500 I	Opp	50				Furnished									
823XDAHX-*3 (43)	500 I	Opp	60				Furnished									
823XGAHX-*3 (44)	500 I	Opp	65				Furnished									
823XJAHX-*3 (40)	500 I	Opp	76				Furnished									
823XMAHX-*3 (38)	500 I	Opp	89				Furnished									
823XRAHX-*3 (42)	400 I	Opp	123				Furnished									
823XTKT-*5 (17)	350 I	Opp	149		8-A-165(45)		Furnished									
880XBAHX-*5 (3)	500 I	Opp	50				Furnished									
880XDAHX-*5 (4)	500 I	Opp	59				Furnished									
880XGAHX-*5 (9)	500 I	Opp	64				Furnished									
880XJAHX-*5 (5)	500 I	Opp	76				Furnished									
880XMAHX-*5 (6)	500 I	Opp	89				Furnished									
880XQAHX-*5 (16)	450 I	Opp	104				Furnished									
880XRAHX-*5 (7)	400 I	Opp	123				Furnished									
880XTAHX-*5 (8)	350 I	Opp	158				Furnished									

† I = Intermittent Torque Only - De-rate Torque Rating 30% for Continuous Duty.

C = Continuous or Intermittent Torque - No need to De-Rate Torque Rating.

IMPORTANT: Refer to the back of this transmission section and read all notes associated with this application page. Some notes may affect the proper PTO selection.

CAUTION: Do not use geared adapters with 442 A and C ratios.

- (1) Input Gear Part No. 5-P-1004
- (2) Input Gear Part No. 5-P-1077
- (3) Input Gear Part No. 5-P-1100
- (4) Input Gear Part No. 5-P-1101
- (5) Input Gear Part No. 5-P-1102
- (6) Input Gear Part No. 5-P-1103

- (7) Input Gear Part No. 5-P-1104
- (8) Input Gear Part No. 5-P-1105
- (9) Input Gear Part No. 5-P-1135
- (10) Input Gear Part No. 5-P-1242
- (11) Input Gear Part No. 5-P-1246
- (12) Input Gear Part No. 5-P-1280

- (13) Input Gear Part No. 5-P-1287
- (14) Input Gear Part No. 5-P-1322
- (15) Input Gear Part No. 5-P-1364
- (16) Input Gear Part No. 5-P-1385
- (17) Input Gear Part No. 5-P-1395
- (18) Input Gear Part No. 5-P-1441

- (19) Input Gear Part No. 5-P-1494
- (38) Input Gear Part No. 5-P-283
- (39) Input Gear Part No. 5-P-285
- (40) Input Gear Part No. 5-P-325
- (42) Input Gear Part No. 5-P-721
- (43) Input Gear Part No. 5-P-971

- (44) Input Gear Part No. 5-P-980
- (45) Filler block furnished with PTO

CHELSEA®

MACK

MAK-20

TRL 10760
TRL 10760

LEFT SIDE ONLY

RIGHT SIDE ONLY

TRANSMISSION GEAR DATA:

L.S. 08-BOLT Opening Gear FORWARD of Centerline
34 Teeth - SPUR

PITCH LINE TO APERTURE FACE:
0.8050" (20.4500MM))

TRANSMISSION GEAR DATA:

R.S. 06-BOLT Opening Gear FORWARD of Centerline
34 Teeth - SPUR

PITCH LINE TO APERTURE FACE:
3.0850" (78.3600MM)

CAUTION: Application Approval Required for PTO Output Shaft Speeds Above 2500 RPM

PTO Model	Torq I / C †	Dir Rot	Engine %		Filler Block	Adapter Assy	Stud Kit	PTO Model	Torq I / C †	Dir Rot	Engine %		Filler Block	Adapter Assy	Stud Kit
			Fwd	Rev							Fwd	Rev			

ONE SPEED - TWO GEAR POWERSHIFT (AIR OR HYDRAULIC)

282XBAJX-*5 (20)	300 C	Opp	50		8-A-032		Furnished	272KAAJX-*3 (29)	300 C	Eng	41			328530-1X	7170-16X
282XCAJX-*5 (21)	300 C	Opp	61		8-A-032		Furnished	272KBAJX-*3 (30)	300 C	Eng	50			328530-1X	7170-16X
282XDAJX-*5 (22)	300 C	Opp	72		8-A-032		Furnished	272KCAJX-*3 (31)	300 C	Eng	61			328530-1X	7170-16X
282XGAJX-*5 (23)	300 C	Opp	86		8-A-032		Furnished	272KDAJX-*3 (32)	300 C	Eng	72			328530-1X	7170-16X
282XKAJX-*5 (24)	300 C	Opp	96		8-A-032		Furnished	272KGAJX-*3 (33)	300 C	Eng	86			328530-1X	7170-16X
282XMAJX-*5 (25)	300 C	Opp	108		8-A-032		Furnished	272KKAJX-*3 (34)	300 C	Eng	96			328530-1X	7170-16X
282XPAJX-*5 (26)	300 C	Opp	120		8-A-032		Furnished	272KMAJX-*3 (35)	300 C	Eng	108			328530-1X	7170-16X
282XSAJX-*5 (27)	300 C	Opp	135		8-A-032		Furnished	272KPAJX-*3 (36)	300 C	Eng	120			328530-1X	7170-16X
282XTAJX-*5 (28)	300 C	Opp	151		8-A-032		Furnished	272KSAJX-*3 (37))	300 C	Eng	135			328530-1X	7170-16X

ONE SPEED - TWO GEAR - POWERSHIFT (AIR)

885XBAHX-*3 (3)	500 I	Opp	50				Furnished								
885XGAHX-*5 (9)	500 I	Opp	64				Furnished								
885XJAHX-*3 (5)	500 I	Opp	76				Furnished								
885XMAHX-*3 (6)	500 I	Opp	89				Furnished								

ONE SPEED - FORWARD & REVERSE

340SFAHX-*5 (41)	200 I	Opp	64	67		310778X	Furnished	340XFAHX-*5 (41)	200 I	Eng	64	67	7-A-140(P)(45)	328530-1X	7170-16X
863XBAHX-*5	500 I	Opp	50	62			Furnished								

GEARED ADAPTERS

628XAHX-4AH	250 I	Eng					Furnished								
-------------	-------	-----	--	--	--	--	-----------	--	--	--	--	--	--	--	--

† I = Intermittent Torque Only - De-rate Torque Rating 30% for Continuous Duty.

C = Continuous or Intermittent Torque - No need to De-Rate Torque Rating.

IMPORTANT: Refer to the back of this transmission section and read all notes associated with this application page. Some notes may affect the proper PTO selection.

CAUTION: Do not use geared adapters with 442 A and C ratios.

- (3) Input Gear Part No. 5-P-1100
- (5) Input Gear Part No. 5-P-1102
- (6) Input Gear Part No. 5-P-1103
- (9) Input Gear Part No. 5-P-1135
- (20) Input Gear Part No. 5-P-1510-11X
- (21) Input Gear Part No. 5-P-1510-12X

- (22) Input Gear Part No. 5-P-1510-13X
- (23) Input Gear Part No. 5-P-1510-14X
- (24) Input Gear Part No. 5-P-1510-15X
- (25) Input Gear Part No. 5-P-1510-16X
- (26) Input Gear Part No. 5-P-1510-17X
- (27) Input Gear Part No. 5-P-1510-18X

- (28) Input Gear Part No. 5-P-1510-19X
- (29) Input Gear Part No. 5-P-1510-1X
- (30) Input Gear Part No. 5-P-1510-2X
- (31) Input Gear Part No. 5-P-1510-3X
- (32) Input Gear Part No. 5-P-1510-4X
- (33) Input Gear Part No. 5-P-1510-5X

- (34) Input Gear Part No. 5-P-1510-6X
- (35) Input Gear Part No. 5-P-1510-7X
- (36) Input Gear Part No. 5-P-1510-8X
- (37) Input Gear Part No. 5-P-1510-9X
- (41) Input Gear Part No. 5-P-581
- (45) Filler block furnished with PTO

MAK-21

MACK

CHELSEA®

TRXL1070
TRXL1070-A
TRXL10710
X1070
X1070-A
X10710
X10710-A

LEFT SIDE ONLY

RIGHT SIDE ONLY

TRANSMISSION GEAR DATA:

L.S. 08-BOLT Opening Gear FORWARD of Centerline
37 Teeth - SPUR

PITCH LINE TO APERTURE FACE:
0.5700" (14.4800MM)

TRANSMISSION GEAR DATA:

R.S. 06-BOLT Opening Gear FORWARD of Centerline
37 Teeth - SPUR

PITCH LINE TO APERTURE FACE:
2.8340" (71.9800MM)

CAUTION: Application Approval Required for PTO Output Shaft Speeds Above 2500 RPM

PTO Model	Torq I / C †	Dir Rot	Engine %		Filler Block	Adapter Assy	Stud Kit	PTO Model	Torq I / C †	Dir Rot	Engine %		Filler Block	Adapter Assy	Stud Kit
			Fwd	Rev							Fwd	Rev			

ONE SPEED - TWO GEAR - MECHANICAL SHIFT

221XCAHX-*5	250 I	Opp	72		7-A-032(P)(44)	328564X	Furnished	221XCAHX-*3	250 I	Eng	72		7-A-032(P)(44)	328530-1X	328170-32X
221XEAHX-*5	250 I	Opp	84			328564X	Furnished	221XEAHX-*3 (3)	250 I	Eng	84		7-A-240(T)	328530-1X	328170-32X
489KAAHX-*5 (12)	250 I	Opp	64		8-A-062		328170-8X	442KFAHX-*3 (2)	250 I	Eng	101		7-A-240(T)	328530-1X	328170-168X
					8-A-093										
489KCAHX-*5 (13)	250 I	Opp	81		8-A-062		328170-8X	442KHAHX-*3 (15)	250 I	Eng	117		7-A-240(T)	328530-1X	328170-168X
					8-A-093										
489KFAHX-*5 (2)	250 I	Opp	101		8-A-062		328170-8X	442KLAHX-*3 (1)	250 I	Eng	130		7-A-240(T)	328530-1X	328170-168X
					8-A-093										
489KHAHX-*5 (15)	250 I	Opp	117		8-A-062		328170-8X	442KQAHX-*3 (1)	225 I	Eng	140		7-A-240(T)	328530-1X	328170-168X
					8-A-093										
489KLAHX-*5 (1)	250 I	Opp	130		8-A-062		328170-8X	442KRAHX-*3 (1)	225 I	Eng	162		7-A-240(T)	328530-1X	328170-168X
					8-A-093										
489KQAHX-*5 (1)	225 I	Opp	140		8-A-062		328170-8X	442KSAHX-*3 (1)	200 I	Eng	193		7-A-240(T)	328530-1X	328170-168X
					8-A-093										
489KRAHX-*5 (1)	225 I	Opp	162		8-A-062		328170-8X	442KUAHX-*3 (1)	195 I	Eng	230		7-A-240(T)	328530-1X	328170-168X
					8-A-093										
489KSAHX-*5 (1)	200 I	Opp	193		8-A-062		328170-8X	442KWAHX-*3 (1)	175 I	Eng	271		7-A-240(T)	328530-1X	328170-168X
					8-A-093										
489KUAHX-*5 (1)	195 I	Opp	230		8-A-062		328170-8X	442KXAHX-*3 (1)	140 I	Eng	321		7-A-240(T)	328530-1X	328170-168X
					8-A-093										
489KWAHX-*5 (1)	175 I	Opp	271		8-A-062		328170-8X	660KHAHX-*3 (15)	375 I	Eng	117		7-A-240(T)	328530-1X	328170-168X
					8-A-093										
489KXAHX-*5 (1)	140 I	Opp	321		8-A-062		328170-8X								
					8-A-093										
680KHAHX-*5 (18)	375 I	Opp	117		8-A-062		328170-8X								
					8-A-093										
680XFAHX-*5 (10)	375 I	Opp	101		8-A-062		328170-8X								
					8-A-093										
680XQAHX-*5 (11)	375 I	Opp	140		8-A-062		328170-8X								
					8-A-093										

† I = Intermittent Torque Only - De-rate Torque Rating 30% for Continuous Duty.

C = Continuous or Intermittent Torque - No need to De-Rate Torque Rating.

IMPORTANT: Refer to the back of this transmission section and read all notes associated with this application page. Some notes may affect the proper PTO selection.

CAUTION: Do not use geared adapters with 442 A and C ratios.

(1) Input Gear Part No. 5-P-1004
(2) Input Gear Part No. 5-P-1077
(10) Input Gear Part No. 5-P-1242
(11) Input Gear Part No. 5-P-1246
(12) Input Gear Part No. 5-P-1280
(13) Input Gear Part No. 5-P-1287

(15) Input Gear Part No. 5-P-1364
(18) Input Gear Part No. 5-P-1494
(44) Filler block furnished with PTO

TRXL1070
TRXL1070-A
TRXL10710
X1070
X1070-A
X10710
X10710-A

LEFT SIDE ONLY

RIGHT SIDE ONLY

TRANSMISSION GEAR DATA:
L.S. 08-BOLT Opening Gear FORWARD of Centerline
37 Teeth - SPUR
PITCH LINE TO APERTURE FACE:
0.5700" (14.4800MM)

TRANSMISSION GEAR DATA:
R.S. 06-BOLT Opening Gear FORWARD of Centerline
37 Teeth - SPUR
PITCH LINE TO APERTURE FACE:
2.8340" (71.9800MM)

CAUTION: Application Approval Required for PTO Output Shaft Speeds Above 2500 RPM

PTO Model	Torq I / C †	Dir Rot	Engine %		Filler Block	Adapter Assy	Stud Kit	PTO Model	Torq I / C †	Dir Rot	Engine %		Filler Block	Adapter Assy	Stud Kit
			Fwd	Rev							Fwd	Rev			

ONE SPEED - TWO GEAR - MECHANICAL SHIFT

680XRAHX-*5 (17)	350 I	Opp	162		8-A-062 8-A-093		328170-8X								
680XSAHX-*5 (14)	325 I	Opp	193		8-A-062 8-A-093		328170-8X								
823XBAHX-*3 (38)	500 I	Opp	69		8-A-190		328170-14X								
823XDAHX-*3 (42)	500 I	Opp	81		8-A-190		328170-14X								
823XGAHX-*3 (43)	500 I	Opp	88		8-A-190		328170-14X								
823XJAHX-*3 (39)	500 I	Opp	104		8-A-190		328170-14X								
823XMAHX-*3 (37)	500 I	Opp	122		8-A-190		328170-14X								
823XRAHX-*3 (41)	400 I	Opp	168		8-A-190		328170-14X								
880XBAHX-*3 (3)	500 I	Opp	69		8-A-190		328170-14X								
880XDAHX-*3 (4)	500 I	Opp	81		8-A-190		328170-14X								
880XGAHX-*3 (9)	500 I	Opp	88		8-A-190		328170-14X								
880XJAHX-*3 (5)	500 I	Opp	104		8-A-190		328170-14X								
880XMAHX-*3 (6)	500 I	Opp	122		8-A-190		328170-14X								
880XQAHX-*3 (16)	450 I	Opp	142		8-A-190		328170-14X								
880XRAHX-*3 (7)	400 I	Opp	168		8-A-190		328170-14X								
880XTAHX-*3 (8)	350 I	Opp	217		8-A-190		328170-14X								

ONE SPEED - TWO GEAR POWERSHIFT (AIR OR HYDRAULIC)

282KBAJX-*5 (19)	300 C	Opp	69		8-A-062(T) 8-A-032		328170-8X	272KAAJX-*3 (28)	300 C	Eng	56		7-A-240(T)	328530-1X	328170-168X
282KCAJX-*5 (20)	300 C	Opp	83		8-A-062(T) 8-A-032		328170-8X	272KBAJX-*3 (29)	300 C	Eng	69		7-A-240(T)	328530-1X	328170-168X
282KDAJX-*5 (21)	300 C	Opp	99		8-A-062(T) 8-A-032		328170-8X	272KCAJX-*3 (30)	300 C	Eng	83		7-A-240(T)	328530-1X	328170-168X
282KGAJX-*5 (22)	300 C	Opp	118		8-A-062(T) 8-A-032		328170-8X	272KDAJX-*3 (31)	300 C	Eng	99		7-A-240(T)	328530-1X	328170-168X
282KKAJX-*5 (23)	300 C	Opp	132		8-A-062(T) 8-A-032		328170-8X	272KGAJX-*3 (32)	300 C	Eng	118		7-A-240(T)	328530-1X	328170-168X
282KMAJX-*5 (24)	300 C	Opp	148		8-A-062(T) 8-A-032		328170-8X	272KKAJX-*3 (33)	300 C	Eng	132		7-A-240(T)	328530-1X	328170-168X

† I = Intermittent Torque Only - De-rate Torque Rating 30% for Continuous Duty.

C = Continuous or Intermittent Torque - No need to De-Rate Torque Rating.

IMPORTANT: Refer to the back of this transmission section and read all notes associated with this application page. Some notes may affect the proper PTO selection.

CAUTION: Do not use geared adapters with 442 A and C ratios.

- (3) Input Gear Part No. 5-P-1100
- (4) Input Gear Part No. 5-P-1101
- (5) Input Gear Part No. 5-P-1102
- (6) Input Gear Part No. 5-P-1103
- (7) Input Gear Part No. 5-P-1104
- (8) Input Gear Part No. 5-P-1105

- (9) Input Gear Part No. 5-P-1135
- (14) Input Gear Part No. 5-P-1322
- (16) Input Gear Part No. 5-P-1385
- (17) Input Gear Part No. 5-P-1441
- (19) Input Gear Part No. 5-P-1510-11X
- (20) Input Gear Part No. 5-P-1510-12X

- (21) Input Gear Part No. 5-P-1510-13X
- (22) Input Gear Part No. 5-P-1510-14X
- (23) Input Gear Part No. 5-P-1510-15X
- (24) Input Gear Part No. 5-P-1510-16X
- (28) Input Gear Part No. 5-P-1510-1X
- (29) Input Gear Part No. 5-P-1510-2X

- (30) Input Gear Part No. 5-P-1510-3X
- (31) Input Gear Part No. 5-P-1510-4X
- (32) Input Gear Part No. 5-P-1510-5X
- (33) Input Gear Part No. 5-P-1510-6X
- (37) Input Gear Part No. 5-P-283
- (38) Input Gear Part No. 5-P-285

- (39) Input Gear Part No. 5-P-325
- (41) Input Gear Part No. 5-P-721
- (42) Input Gear Part No. 5-P-971
- (43) Input Gear Part No. 5-P-980

MAK-21

MACK

CHELSEA®

TRXL1070
TRXL1070-A
TRXL10710
X1070
X1070-A
X10710
X10710-A

LEFT SIDE ONLY

RIGHT SIDE ONLY

TRANSMISSION GEAR DATA:

L.S. 08-BOLT Opening Gear FORWARD of Centerline
37 Teeth - SPUR

PITCH LINE TO APERTURE FACE:

0.5700" (14.4800MM)

TRANSMISSION GEAR DATA:

R.S. 06-BOLT Opening Gear FORWARD of Centerline
37 Teeth - SPUR

PITCH LINE TO APERTURE FACE:

2.8340" (71.9800MM)

CAUTION: Application Approval Required for PTO Output Shaft Speeds Above 2500 RPM

PTO Model	Torq I / C †	Dir Rot	Engine %		Filler Block	Adapter Assy	Stud Kit	PTO Model	Torq I / C †	Dir Rot	Engine %		Filler Block	Adapter Assy	Stud Kit
			Fwd	Rev							Fwd	Rev			
ONE SPEED - TWO GEAR POWERSHIFT (AIR OR HYDRAULIC)															
282KPAJX-*5 (25)	300 C	Opp	165		8-A-062(T) 8-A-032		328170-8X	272KMAJX-*3 (34)	300 C	Eng	148		7-A-240(T)	328530-1X	328170-168X
282KSAJX-*5 (26)	271 C	Opp	184		8-A-062(T) 8-A-032		328170-8X	272KPAJX-*3 (35)	300 C	Eng	165		7-A-240(T)	328530-1X	328170-168X
282KTAJX-*5 (27)	242 C	Opp	206		8-A-062(T) 8-A-032		328170-8X	272KSAJX-*3 (36)	271 C	Eng	184		7-A-240(T)	328530-1X	328170-168X
ONE SPEED - TWO GEAR - POWERSHIFT (AIR)															
885XBAHX-*3 (3)	500 I	Opp	69		8-A-190		328170-14X								
885XGAHX-*3 (9)	500 I	Opp	88		8-A-190		328170-14X								
885XJAHX-*3 (5)	500 I	Opp	104		8-A-190		328170-14X								
885XMAHX-*3 (6)	500 I	Opp	122		8-A-190		328170-14X								
ONE SPEED - FORWARD & REVERSE															
340XFAHX-*5 (40)	200 I	Opp	88	92	7-A-140(P)(44)	328564X	Furnished	340XFAHX-*5 (40)	200 I	Eng	88	92	7-A-140(P)(44)	328530-1X	328170-168X
863XBAHX-*5	500 I	Opp	69	85	8-A-190		328170-15X						7-A-240(T)		
GEARED ADAPTERS															
628XAHX-4AH	250 I	Eng			8-A-190		328170-8X								

† I = Intermittent Torque Only - De-rate Torque Rating 30% for Continuous Duty.

C = Continuous or Intermittent Torque - No need to De-Rate Torque Rating.

IMPORTANT: Refer to the back of this transmission section and read all notes associated with this application page.
Some notes may affect the proper PTO selection.**CAUTION:** Do not use geared adapters with 442 A and C ratios.(3) Input Gear Part No. 5-P-1100
(5) Input Gear Part No. 5-P-1102
(6) Input Gear Part No. 5-P-1103
(9) Input Gear Part No. 5-P-1135
(25) Input Gear Part No. 5-P-1510-17X
(26) Input Gear Part No. 5-P-1510-18X(27) Input Gear Part No. 5-P-1510-19X
(34) Input Gear Part No. 5-P-1510-7X
(35) Input Gear Part No. 5-P-1510-8X
(36) Input Gear Part No. 5-P-1510-9X
(40) Input Gear Part No. 5-P-581
(44) Filler block furnished with PTO

TRL107

LEFT SIDE ONLY

RIGHT SIDE ONLY

TRANSMISSION GEAR DATA:

L.S. 08-BOLT Opening Gear FORWARD of Centerline
34 Teeth - SPUR

PITCH LINE TO APERTURE FACE:

0.6250" (15.8800MM)

TRANSMISSION GEAR DATA:

R.S. 06-BOLT Opening Gear FORWARD of Centerline
34 Teeth - SPUR

PITCH LINE TO APERTURE FACE:

3.0850" (78.3600MM)

CAUTION: Application Approval Required for PTO Output Shaft Speeds Above 2500 RPM

PTO Model	Torq I / C †	Dir Rot	Engine %		Filler Block	Adapter Assy	Stud Kit	PTO Model	Torq I / C †	Dir Rot	Engine %		Filler Block	Adapter Assy	Stud Kit
			Fwd	Rev							Fwd	Rev			

ONE SPEED - TWO GEAR - MECHANICAL SHIFT

221ZCAHX-*5	250 I	Opp	32		7-A-032(P)(43)	328564X	Furnished	221XCAHX-*3	250 I	Eng	32		7-A-032(P)(43)	328530-1X	328170-83X
221ZEAHX-*5	250 I	Opp	37			328564X	Furnished	221XEAHX-*3	250 I	Eng	37			328530-1X	328170-83X
489XAAHX-*5 (10)	250 I	Opp	28				Furnished	442KFAHX-*3 (2)	250 I	Eng	45			328530-1X	7170-16X
489XCAHX-*5 (11)	250 I	Opp	36				Furnished	442KHAHX-*3 (13)	250 I	Eng	72			328530-1X	7170-16X
489XFAHX-*5 (2)	250 I	Opp	45				Furnished	442KLAHX-*3 (1)	250 I	Eng	58			328530-1X	7170-16X
489XHAHX-*5 (13)	250 I	Opp	72				Furnished	442KQAHX-*3 (1)	225 I	Eng	62			328530-1X	7170-16X
489XLAHX-*5 (1)	250 I	Opp	58				Furnished	442KRAHX-*3 (1)	225 I	Eng	72			328530-1X	7170-16X
489XQAHX-*5 (1)	225 I	Opp	62				Furnished	442KSAHX-*3 (1)	200 I	Eng	86			328530-1X	7170-16X
489XRAHX-*5 (1)	225 I	Opp	72				Furnished	442KUAHX-*3 (1)	195 I	Eng	102			328530-1X	7170-16X
489XSAHX-*5 (1)	200 I	Opp	86				Furnished	442KWAHX-*3 (1)	175 I	Eng	121			328530-1X	7170-16X
489XUAHX-*5 (1)	195 I	Opp	102				Furnished	442KXAHX-*3 (1)	140 I	Eng	143			328530-1X	7170-16X
489XWAHX-*5 (1)	175 I	Opp	121				Furnished	660KHAHX-*3 (13)	375 I	Eng	72			328530-1X	7170-16X
489XXAHX-*5 (1)	140 I	Opp	143				Furnished								
680XFAHX-*5 (8)	375 I	Opp	45				Furnished								
680XHAHX-*5 (17)	375 I	Opp	72				Furnished								
680XQAHX-*5 (9)	375 I	Opp	62				Furnished								
680XRAHX-*5 (16)	350 I	Opp	72				Furnished								
680XSAHX-*5 (12)	325 I	Opp	86				Furnished								
823XBAHX-*3 (37)	500 I	Opp	30				Furnished								
823XDAHX-*3 (41)	500 I	Opp	36				Furnished								
823XGAHX-*3 (42)	500 I	Opp	39				Furnished								
823XJAHX-*3 (38)	500 I	Opp	46				Furnished								
823XMAHX-*3 (36)	500 I	Opp	54				Furnished								
823XRAHX-*3 (40)	400 I	Opp	75				Furnished								
823XTKTX-*3 (15)	350 I	Opp	90		8-A-165(43)		Furnished								
880XBAHX-*3 (3)	500 I	Opp	30				Furnished								
880XJAHX-*3 (4)	500 I	Opp	46				Furnished								
880XMAHX-*3 (5)	500 I	Opp	54				Furnished								
880XQAHX-*3 (14)	450 I	Opp	64				Furnished								
880XRAHX-*3 (6)	400 I	Opp	75				Furnished								
880XTAHX-*3 (7)	350 I	Opp	96				Furnished								

† I = Intermittent Torque Only - De-rate Torque Rating 30% for Continuous Duty.

C = Continuous or Intermittent Torque - No need to De-Rate Torque Rating.

IMPORTANT: Refer to the back of this transmission section and read all notes associated with this application page. Some notes may affect the proper PTO selection.

- (1) Input Gear Part No. 5-P-1004
- (2) Input Gear Part No. 5-P-1077
- (3) Input Gear Part No. 5-P-1100
- (4) Input Gear Part No. 5-P-1100
- (5) Input Gear Part No. 5-P-1103
- (6) Input Gear Part No. 5-P-1104

- (7) Input Gear Part No. 5-P-1105
- (8) Input Gear Part No. 5-P-1242
- (9) Input Gear Part No. 5-P-1246
- (10) Input Gear Part No. 5-P-1280
- (11) Input Gear Part No. 5-P-1287
- (12) Input Gear Part No. 5-P-1322

- (13) Input Gear Part No. 5-P-1364
- (14) Input Gear Part No. 5-P-1385
- (15) Input Gear Part No. 5-P-1395
- (16) Input Gear Part No. 5-P-1441
- (17) Input Gear Part No. 5-P-1494
- (36) Input Gear Part No. 5-P-283

- (37) Input Gear Part No. 5-P-285
- (38) Input Gear Part No. 5-P-325
- (40) Input Gear Part No. 5-P-721
- (41) Input Gear Part No. 5-P-871
- (42) Input Gear Part No. 5-P-980
- (43) Filler block furnished with PTO

MAK-22

MACK

CHELSEA®

TRL107

LEFT SIDE ONLY

RIGHT SIDE ONLY

TRANSMISSION GEAR DATA:

L.S. 08-BOLT Opening Gear FORWARD of Centerline
34 Teeth - SPUR

PITCH LINE TO APERTURE FACE:
0.6250" (15.8800MM)

TRANSMISSION GEAR DATA:

R.S. 06-BOLT Opening Gear FORWARD of Centerline
34 Teeth - SPUR

PITCH LINE TO APERTURE FACE:
3.0850" (78.3600MM)

CAUTION: Application Approval Required for PTO Output Shaft Speeds Above 2500 RPM

PTO Model	Torq I / C †	Dir Rot	Engine %		Filler Block	Adapter Assy	Stud Kit	PTO Model	Torq I / C †	Dir Rot	Engine %		Filler Block	Adapter Assy	Stud Kit
			Fwd	Rev							Fwd	Rev			
ONE SPEED - TWO GEAR POWERSHIFT (AIR OR HYDRAULIC)															
282XBAJX-*5 (18)	300 C	Opp	31		8-A-032		Furnished	272KAAJX-*3 (27)	300 C	Eng	25		328530-1X		7170-16X
282XCAJX-*5 (19)	300 C	Opp	37		8-A-032		Furnished	272KBAJX-*3 (28)	300 C	Eng	31		328530-1X		7170-16X
282XDAJX-*5 (20)	300 C	Opp	44		8-A-032		Furnished	272KCAJX-*3 (29)	300 C	Eng	37		328530-1X		7170-16X
282XGAJX-*5 (21)	300 C	Opp	52		8-A-032		Furnished	272KDAJX-*3 (30)	300 C	Eng	44		328530-1X		7170-16X
282XKAJX-*5 (22)	300 C	Opp	59		8-A-032		Furnished	272KGAJX-*3 (31)	300 C	Eng	52		328530-1X		7170-16X
282XMAJX-*5 (23)	300 C	Opp	66		8-A-032		Furnished	272KKAJX-*3 (32)	300 C	Eng	59		328530-1X		7170-16X
282XPAJX-*5 (24)	300 C	Opp	73		8-A-032		Furnished	272KMAJX-*3 (33)	300 C	Eng	66		328530-1X		7170-16X
282XSAJX-*5 (25)	300 C	Opp	82		8-A-032		Furnished	272KPAJX-*3 (34)	300 C	Eng	73		328530-1X		7170-16X
282XTAJX-*5 (26)	300 C	Opp	92		8-A-032		Furnished	272KSAJX-*3 (35)	300 C	Eng	82		328530-1X		7170-16X
ONE SPEED - TWO GEAR - POWERSHIFT (AIR)															
885XBAHX-*3 (3)	500 I	Opp	30				Furnished								
885XJAHX-*3 (4)	500 I	Opp	46				Furnished								
885XMAHX-*3 (5)	500 I	Opp	54				Furnished								
ONE SPEED - FORWARD & REVERSE															
340SFAHX-*5 (39)	200 I	Opp	39	41		310778X	Furnished	340XFAHX-*5 (39)	200 I	Eng	39	41	7-A-140(P)(43)	328530-1X	7170-16X
863XBAHX-*5	500 I	Opp	30	38			Furnished								
GEARED ADAPTERS															
628XAHX-4AH	250 I	Eng					Furnished								

† I = Intermittent Torque Only - De-rate Torque Rating 30% for Continuous Duty.

C = Continuous or Intermittent Torque - No need to De-Rate Torque Rating.

IMPORTANT: Refer to the back of this transmission section and read all notes associated with this application page. Some notes may affect the proper PTO selection.

Mack

- (3) Input Gear Part No. 5-P-1100
- (4) Input Gear Part No. 5-P-1102
- (5) Input Gear Part No. 5-P-1103
- (18) Input Gear Part No. 5-P-1510-11X
- (19) Input Gear Part No. 5-P-1510-12X
- (20) Input Gear Part No. 5-P-1510-13X

- (21) Input Gear Part No. 5-P-1510-14X
- (22) Input Gear Part No. 5-P-1510-15X
- (23) Input Gear Part No. 5-P-1510-16X
- (24) Input Gear Part No. 5-P-1510-17X
- (25) Input Gear Part No. 5-P-1510-18X
- (26) Input Gear Part No. 5-P-1510-19X

- (27) Input Gear Part No. 5-P-1510-1X
- (28) Input Gear Part No. 5-P-1510-2X
- (29) Input Gear Part No. 5-P-1510-3X
- (30) Input Gear Part No. 5-P-1510-4X
- (31) Input Gear Part No. 5-P-1510-5X
- (32) Input Gear Part No. 5-P-1510-6X

- (33) Input Gear Part No. 5-P-1510-7X
- (34) Input Gear Part No. 5-P-1510-8X
- (35) Input Gear Part No. 5-P-1510-9X
- (39) Input Gear Part No. 5-P-581
- (43) Filler block furnished with PTO

T2090 T2090-L T2130 (Front Box) T2130-B (Front Box) T2180 (Front Box) T2180-B (Front Box) T309 T309L	T309LR T310-MLR (Front Box) T313H (Front Box) T313L (Front Box) T313L21 (Front Box) T313LR (Front Box) T313LR21 (Front Box) T318 (Front Box)	T318L (Front Box) T318L21 (Front Box) T318LR (Front Box) T318LR21 (Front Box) TM308M (Front box) TM309M (Front Box)
---	---	--

LEFT SIDE ONLY	RIGHT SIDE ONLY
TRANSMISSION GEAR DATA: L.S. 08-BOLT Opening Gear FORWARD of Centerline 54 Teeth - SPUR PITCH LINE TO APERTURE FACE: 0.8100" (20.5700MM)	TRANSMISSION GEAR DATA: R.S. 06-BOLT Opening Gear FORWARD of Centerline 54 Teeth - SPUR PITCH LINE TO APERTURE FACE: 1.0850" (27.5600MM)

CAUTION: Application Approval Required for PTO Output Shaft Speeds Above 2500 RPM

PTO Model	Torq I / C †	Dir Rot	Engine %		Filler Block	Adapter Assy	Stud Kit	PTO Model	Torq I / C †	Dir Rot	Engine %		Filler Block	Adapter Assy	Stud Kit
			Fwd	Rev							Fwd	Rev			

ONE SPEED - TWO GEAR - MECHANICAL SHIFT

221ZCDAX-*5	250 I	Opp	68			328564X	Furnished	221XCAHX-*3	250 I	Eng	67		7-A-032(P)(38)	328554-2X	Furnished
221ZEDAX-*5	250 I	Opp	75			328564X	Furnished	221XCDAX-*3	250 I	Opp	68				Furnished
489ZADAX-*5 (10)	250 I	Opp	59				Furnished	221XEAHX-*3	250 I	Eng	77			328554-2X	Furnished
489ZCDAX-*5 (11)	250 I	Opp	76				Furnished	221XEDAX-*3	250 I	Opp	75				Furnished
489ZFDAX-*5 (4)	250 I	Opp	94				Furnished	442XFAHX-*3 (3)	250 I	Eng	93			328554-2X	Furnished
489ZHDAX-*5 (15)	250 I	Opp	109				Furnished	442XHAHX-*3 (15)	250 I	Eng	109			328554-2X	Furnished
489ZLDAX-*5 (2)	250 I	Opp	121				Furnished	442XLAHX-*3 (1)	250 I	Eng	120			328554-2X	Furnished
489ZQDAX-*5 (2)	225 I	Opp	130				Furnished	442XQAHX-*3 (1)	225 I	Eng	130			328554-2X	Furnished
489ZRDAX-*5 (2)	225 I	Opp	151				Furnished	442XRAHX-*3 (1)	225 I	Eng	150			328554-2X	Furnished
489ZSDAX-*5 (2)	200 I	Opp	180				Furnished	442XSAHX-*3 (1)	200 I	Eng	179			328554-2X	Furnished
489ZUDAX-*5 (2)	195 I	Opp	214				Furnished	442XUAHX-*3 (1)	195 I	Eng	213			328554-2X	Furnished
489ZWDAX-*5 (2)	175 I	Opp	252				Furnished	442XWAHX-*3 (1)	175 I	Eng	250			328554-2X	Furnished
489ZXDAX-*5 (2)	140 I	Opp	298				Furnished	442XXAHX-*3 (1)	140 I	Eng	296			328554-2X	Furnished
680ZFDAX-*5 (12)	375 I	Opp	94				Furnished	442ZADAX-*3 (10)	250 I	Opp	59		7-A-062		Furnished
680ZQDAX-*5 (13)	375 I	Opp	130				Furnished	442ZCDAX-*3 (11)	250 I	Opp	76		7-A-062		Furnished
680ZSDAX-*5 (14)	325 I	Opp	180				Furnished	442ZFDAX-*3 (4)	250 I	Opp	94		7-A-062		Furnished
823XBDAX-*5 (35)	500 I	Opp	61				Furnished	442ZHDAX-*3 (15)	250 I	Opp	109		7-A-062		Furnished
823XMDAX-*5 (36)	500 I	Opp	108				Furnished	442ZLDAX-*3 (2)	250 I	Opp	121		7-A-062		Furnished
823XRDAX-*5 (37)	400 I	Opp	150				Furnished	442ZQDAX-*3 (2)	225 I	Opp	130		7-A-062		Furnished
880XBDAX-*5 (5)	500 I	Opp	61				Furnished	442ZRDAX-*3 (2)	225 I	Opp	151		7-A-062		Furnished
880XGDAX-*5 (9)	500 I	Opp	78				Furnished	442ZSDAX-*3 (2)	200 I	Opp	180		7-A-062		Furnished
880XMDAX-*5 (6)	500 I	Opp	108				Furnished	442ZUDAX-*3 (2)	195 I	Opp	214		7-A-062		Furnished
880XRDAX-*5 (7)	400 I	Opp	150				Furnished	442ZWDAX-*3 (2)	175 I	Opp	252		7-A-062		Furnished
880XTDAX-*5 (8)	350 I	Opp	193				Furnished	442ZXDAX-*3 (2)	140 I	Opp	298		7-A-062		Furnished
								660XHHAHX-*3 (15)	375 I	Eng	109			328554-2X	Furnished
								660ZFDAX-*3 (12)	375 I	Opp	94		7-A-062		Furnished
								660ZQDAX-*3 (13)	375 I	Opp	130		7-A-062		Furnished
								660ZSDAX-*3 (14)	325 I	Opp	180		7-A-062		Furnished

ONE SPEED - TWO GEAR POWERSHIFT (AIR OR HYDRAULIC)

282XBDAX-*5 (16)	300 C	Opp	62				Furnished	272XADAX-*3 (25)	300 C	Opp	50				Furnished
282XCDAX-*5 (17)	300 C	Opp	75				Furnished	272XBDAX-*3 (26)	300 C	Opp	62				Furnished

† I = Intermittent Torque Only - De-rate Torque Rating 30% for Continuous Duty.

C = Continuous or Intermittent Torque - No need to De-Rate Torque Rating.

IMPORTANT: Refer to the back of this transmission section and read all notes associated with this application page. Some notes may affect the proper PTO selection.

CAUTION: Do not use geared adapters with 442 A and C ratios.

- (1) Input Gear Part No. 5-P-1004
- (2) Input Gear Part No. 5-P-1037
- (3) Input Gear Part No. 5-P-1077
- (4) Input Gear Part No. 5-P-1085
- (5) Input Gear Part No. 5-P-1120
- (6) Input Gear Part No. 5-P-1121

- (7) Input Gear Part No. 5-P-1122
- (8) Input Gear Part No. 5-P-1123
- (9) Input Gear Part No. 5-P-1174
- (10) Input Gear Part No. 5-P-1284
- (11) Input Gear Part No. 5-P-1291
- (12) Input Gear Part No. 5-P-1330

- (13) Input Gear Part No. 5-P-1331
- (14) Input Gear Part No. 5-P-1332
- (15) Input Gear Part No. 5-P-1365
- (16) Input Gear Part No. 5-P-1511-11X
- (17) Input Gear Part No. 5-P-1511-12X
- (25) Input Gear Part No. 5-P-1511-1X

- (26) Input Gear Part No. 5-p-1511-2X
- (35) Input Gear Part No. 5-P-636
- (36) Input Gear Part No. 5-P-637
- (37) Input Gear Part No. 5-P-808
- (38) Filler block furnished with PTO

MAK-23

MACK

CHELSEA®

T2090 T2090-L T2130 (Front Box) T2130-B (Front Box) T2180 (Front Box) T2180-B (Front Box) T309 T309L	T309LR T310-MLR (Front Box) T313H (Front Box) T313L (Front Box) T313LR (Front Box) T313LR21 (Front Box) T318 (Front Box)	T318L (Front Box) T318L21 (Front Box) T318LR (Front Box) T318LR21 (Front Box) TM308M (Front box) TM309M (Front Box)
---	--	--

LEFT SIDE ONLY	RIGHT SIDE ONLY
TRANSMISSION GEAR DATA: L.S. 08-BOLT Opening Gear FORWARD of Centerline 54 Teeth - SPUR PITCH LINE TO APERTURE FACE: 0.8100" (20.5700MM)	TRANSMISSION GEAR DATA: R.S. 06-BOLT Opening Gear FORWARD of Centerline 54 Teeth - SPUR PITCH LINE TO APERTURE FACE: 1.0850" (27.5600MM)

CAUTION: Application Approval Required for PTO Output Shaft Speeds Above 2500 RPM

PTO Model	Torq I / C †	Dir Rot	Engine %		Filler Block	Adapter Assy	Stud Kit	PTO Model	Torq I / C †	Dir Rot	Engine %		Filler Block	Adapter Assy	Stud Kit
			Fwd	Rev							Fwd	Rev			
ONE SPEED - TWO GEAR POWERSHIFT (AIR OR HYDRAULIC)															
282XDAX-5 (18)	300 C	Opp	89				Furnished	272XCDAX-3 (27)	300 C	Opp	75				Furnished
282XGDAX-5 (19)	300 C	Opp	106				Furnished	272XDDAX-3 (28)	300 C	Opp	89				Furnished
282XKDAX-5 (20)	300 C	Opp	119				Furnished	272XGDAX-3 (29)	300 C	Opp	106				Furnished
282XMDAX-5 (21)	300 C	Opp	133				Furnished	272XKDAX-3 (30)	300 C	Opp	119				Furnished
282XPDAX-5 (22)	300 C	Opp	148				Furnished	272XMDAX-3 (31)	300 C	Opp	133				Furnished
282XSDAX-5 (23)	300 C	Opp	166				Furnished	272XPDAX-3 (32)	300 C	Opp	148				Furnished
282XTDAX-5 (24)	269 C	Opp	186				Furnished	272XSDAX-3 (33)	300 C	Opp	166				Furnished

ONE SPEED - POWERSHIFT LOW PROFILE (AIR OR HYDRAULIC)															
								272MADAX-3 (25)	300 C	Opp	50				Furnished
								272MBDAX-3 (26)	300 C	Opp	62				Furnished
								272MCDAX-3 (27)	300 C	Opp	75				Furnished
								272MDDAX-3 (28)	300 C	Opp	89				Furnished
								272MGDAX-3 (29)	300 C	Opp	106				Furnished
								272MKDAX-3 (30)	300 C	Opp	119				Furnished
								272MMDAX-3 (31)	300 C	Opp	133				Furnished
								272MPDAX-3 (32)	300 C	Opp	148				Furnished
								272MSDAX-3 (33)	300 C	Opp	166				Furnished

ONE SPEED - TWO GEAR - POWERSHIFT (AIR)															
885XBDAX-5 (5)	500 I	Opp	61				Furnished								
885XGDAX-5 (9)	500 I	Opp	78				Furnished								
885XMDAX-5 (6)	500 I	Opp	108				Furnished								

ONE SPEED - FORWARD & REVERSE															
348ZFDAX-5 (34)	200 I	Opp	85	90			Furnished	340SFDAX-5 (34)	200 I	Opp	85	90			Furnished
863XBDAX-5	500 I	Opp	61	75			Furnished								

GEARED ADAPTERS															
628ZDAX-3DA	250 I	Eng					Furnished	626ZDAX-3DA	250 I	Eng			7-A-062		Furnished
								630ZDAX-3DA	250 I	Eng			7-A-062		Furnished
								645ZDAX-3DA	250 I	Eng			7-A-062		Furnished

† I = Intermittent Torque Only - De-rate Torque Rating 30% for Continuous Duty. C = Continuous or Intermittent Torque - No need to De-Rate Torque Rating.

IMPORTANT: Refer to the back of this transmission section and read all notes associated with this application page. Some notes may affect the proper PTO selection.

CAUTION: Do not use geared adapters with 442 A and C ratios.

- | | | | |
|---------------------------------------|---------------------------------------|--------------------------------------|--------------------------------------|
| (5) Input Gear Part No. 5-P-1120 | (21) Input Gear Part No. 5-P-1511-16X | (27) Input Gear Part No. 5-P-1511-3X | (33) Input Gear Part No. 5-P-1511-9X |
| (6) Input Gear Part No. 5-P-1121 | (22) Input Gear Part No. 5-P-1511-17X | (28) Input Gear Part No. 5-P-1511-4X | (34) Input Gear Part No. 5-P-634 |
| (9) Input Gear Part No. 5-P-1174 | (23) Input Gear Part No. 5-P-1511-18X | (29) Input Gear Part No. 5-P-1511-5X | |
| (18) Input Gear Part No. 5-P-1511-13X | (24) Input Gear Part No. 5-P-1511-19X | (30) Input Gear Part No. 5-P-1511-6X | |
| (19) Input Gear Part No. 5-P-1511-14X | (25) Input Gear Part No. 5-P-1511-1X | (31) Input Gear Part No. 5-P-1511-7X | |
| (20) Input Gear Part No. 5-P-1511-15X | (26) Input Gear Part No. 5-p-1511-2X | (32) Input Gear Part No. 5-P-1511-8X | |

T2100
T2110-B (FRONT BOX FOR T2110B)

LEFT SIDE ONLY

RIGHT SIDE ONLY

TRANSMISSION GEAR DATA:

L.S. 08-BOLT Opening Gear FORWARD of Centerline
54 Teeth - SPUR

PITCH LINE TO APERTURE FACE:

0.8100" (20.5700MM)

TRANSMISSION GEAR DATA:

R.S. 06-BOLT Opening Gear FORWARD of Centerline
54 Teeth - SPUR

PITCH LINE TO APERTURE FACE:

1.0850" (27.5600MM)

CAUTION: Application Approval Required for PTO Output Shaft Speeds Above 2500 RPM

PTO Model	Torq I / C †	Dir Rot	Engine %		Filler Block	Adapter Assy	Stud Kit	PTO Model	Torq I / C †	Dir Rot	Engine %		Filler Block	Adapter Assy	Stud Kit
			Fwd	Rev							Fwd	Rev			

ONE SPEED - TWO GEAR - MECHANICAL SHIFT

221ZCDAX-*5	250 I	Opp	63			328564X	Furnished	221XCAHX-*3	250 I	Eng	62	7-A-032(P)(38)	328554-2X	Furnished
221ZEDAX-*5	250 I	Opp	70			328564X	Furnished	221XCDAX-*3	250 I	Opp	63			Furnished
489ZADAX-*5 (10)	250 I	Opp	55				Furnished	221XEAHX-*3	250 I	Eng	72		328554-2X	Furnished
489ZCDAX-*5 (11)	250 I	Opp	70				Furnished	221XEDAX-*3	250 I	Opp	70			Furnished
489ZFDAX-*5 (4)	250 I	Opp	87				Furnished	442XFAHX-*3 (3)	250 I	Eng	86		328554-2X	Furnished
489ZHDAX-*5 (15)	250 I	Opp	101				Furnished	442XHAXH-*3 (15)	250 I	Eng	101		328554-2X	Furnished
489ZLDAX-*5 (2)	250 I	Opp	113				Furnished	442XLAHX-*3 (1)	250 I	Eng	112		328554-2X	Furnished
489ZQDAX-*5 (2)	225 I	Opp	121				Furnished	442XQAHX-*3 (1)	225 I	Eng	120		328554-2X	Furnished
489ZRDAX-*5 (2)	225 I	Opp	140				Furnished	442XRAHX-*3 (1)	225 I	Eng	139		328554-2X	Furnished
489ZSDAX-*5 (2)	200 I	Opp	167				Furnished	442XSAHX-*3 (1)	200 I	Eng	166		328554-2X	Furnished
489ZUDAX-*5 (2)	195 I	Opp	199				Furnished	442XUAHX-*3 (1)	195 I	Eng	198		328554-2X	Furnished
489ZWDAX-*5 (2)	175 I	Opp	234				Furnished	442XWAHX-*3 (1)	175 I	Eng	233		328554-2X	Furnished
489ZXDAX-*5 (2)	140 I	Opp	277				Furnished	442XXAHX-*3 (1)	140 I	Eng	275		328554-2X	Furnished
680ZFDAX-*5 (12)	375 I	Opp	87				Furnished	442ZADAX-*3 (10)	250 I	Opp	55	7-A-062		Furnished
680ZQDAX-*5 (13)	375 I	Opp	121				Furnished	442ZCDAX-*3 (11)	250 I	Opp	70	7-A-062		Furnished
680ZSDAX-*5 (14)	325 I	Opp	167				Furnished	442ZFDAX-*3 (4)	250 I	Opp	87	7-A-062		Furnished
823XBDAX-*5 (35)	500 I	Opp	57				Furnished	442ZHDAX-*3 (15)	250 I	Opp	101	7-A-062		Furnished
823XMDAX-*5 (36)	500 I	Opp	101				Furnished	442ZLDAX-*3 (2)	250 I	Opp	113	7-A-062		Furnished
823XRDAX-*5 (37)	400 I	Opp	139				Furnished	442ZQDAX-*3 (2)	225 I	Opp	121	7-A-062		Furnished
880XBDAX-*5 (5)	500 I	Opp	57				Furnished	442ZRDAX-*3 (2)	225 I	Opp	140	7-A-062		Furnished
880XGDAX-*5 (9)	500 I	Opp	73				Furnished	442ZSDAX-*3 (2)	200 I	Opp	167	7-A-062		Furnished
880XMDAX-*5 (6)	500 I	Opp	101				Furnished	442ZUDAX-*3 (2)	195 I	Opp	199	7-A-062		Furnished
880XRDAX-*5 (7)	400 I	Opp	139				Furnished	442ZWDAX-*3 (2)	175 I	Opp	234	7-A-062		Furnished
880XTDAX-*5 (8)	350 I	Opp	179				Furnished	442ZXDAX-*3 (2)	140 I	Opp	277	7-A-062		Furnished
								660XHAHX-*3 (15)	375 I	Eng	101		328554-2X	Furnished
								660ZFDAX-*3 (12)	375 I	Opp	87	7-A-062		Furnished
								660ZQDAX-*3 (13)	375 I	Opp	121	7-A-062		Furnished
								660ZSDAX-*3 (14)	325 I	Opp	167	7-A-062		Furnished

ONE SPEED - TWO GEAR POWERSHIFT (AIR OR HYDRAULIC)

282XBDAX-*5 (16)	300 I	Opp	57				Furnished	272XADAX-*3 (25)	300 C	Opp	47			Furnished
282XCDAX-*5 (17)	300 I	Opp	69				Furnished	272XBDAX-*3 (26)	300 C	Opp	57			Furnished

† I = Intermittent Torque Only - De-rate Torque Rating 30% for Continuous Duty.

C = Continuous or Intermittent Torque - No need to De-Rate Torque Rating.

IMPORTANT: Refer to the back of this transmission section and read all notes associated with this application page. Some notes may affect the proper PTO selection.

CAUTION: Do not use geared adapters with 442 A and C ratios.

- (1) Input Gear Part No. 5-P-1004
- (2) Input Gear Part No. 5-P-1037
- (3) Input Gear Part No. 5-P-1077
- (4) Input Gear Part No. 5-P-1085
- (5) Input Gear Part No. 5-P-1120
- (6) Input Gear Part No. 5-P-1211

- (7) Input Gear Part No. 5-P-1122
- (8) Input Gear Part No. 5-P-1123
- (9) Input Gear Part No. 5-P-1174
- (10) Input Gear Part No. 5-P-1284
- (11) Input Gear Part No. 5-P-1291
- (12) Input Gear Part No. 5-P-1330

- (13) Input Gear Part No. 5-P-1331
- (14) Input Gear Part No. 5-P-1332
- (15) Input Gear Part No. 5-P-1365
- (16) Input Gear Part No. 5-P-1511-11X
- (17) Input Gear Part No. 5-P-1511-12X
- (25) Input Gear Part No. 5-P-1511-1X

- (26) Input Gear Part No. 5-p-1511-2X
- (35) Input Gear Part No. 5-P-636
- (36) Input Gear Part No. 5-P-637
- (37) Input Gear Part No. 5-P-808
- (38) Filler block furnished with PTO

MAK-24

MACK

CHELSEA®

T2100
T2110-B (FRONT BOX FOR T2110B)

LEFT SIDE ONLY

RIGHT SIDE ONLY

TRANSMISSION GEAR DATA:

L.S. 08-BOLT Opening Gear FORWARD of Centerline
54 Teeth - SPUR

PITCH LINE TO APERTURE FACE:
0.8100" (20.5700MM)

TRANSMISSION GEAR DATA:

R.S. 06-BOLT Opening Gear FORWARD of Centerline
54 Teeth - SPUR

PITCH LINE TO APERTURE FACE:
1.0850" (27.5600MM)

CAUTION: Application Approval Required for PTO Output Shaft Speeds Above 2500 RPM

PTO Model	Torq I / C †	Dir Rot	Engine %		Filler Block	Adapter Assy	Stud Kit	PTO Model	Torq I / C †	Dir Rot	Engine %		Filler Block	Adapter Assy	Stud Kit
			Fwd	Rev							Fwd	Rev			

ONE SPEED - TWO GEAR - POWERSHIFT (AIR OR HYDRAULIC)

282XDDAX-*5 (18)	300 C	Opp	83				Furnished	272XCDAX-*3 (27)	300 C	Opp	69				Furnished
282XGDAX-*5 (19)	300 C	Opp	99				Furnished	272XDDAX-*3 (28)	300 C	Opp	83				Furnished
282XKDAX-*5 (20)	300 C	Opp	110				Furnished	272XGDAX-*3 (29)	300 C	Opp	99				Furnished
282XMDAX-*5 (21)	300 C	Opp	123				Furnished	272XKDAX-*3 (30)	300 C	Opp	110				Furnished
282XPDAX-*5 (22)	300 C	Opp	138				Furnished	272XMDAX-*3 (31)	300 C	Opp	123				Furnished
282XSDAX-*5 (23)	300 C	Opp	154				Furnished	272XPDAX-*3 (32)	300 C	Opp	138				Furnished
282XTDAX-*5 (24)	290 C	Opp	172				Furnished	272XSDAX-*3 (33)	300 C	Opp	154				Furnished

ONE SPEED - POWERSHIFT LOW PROFILE (AIR OR HYDRAULIC)

								272MADAX-*3 (25)	300 C	Opp	47				Furnished
								272MBDAX-*3 (26)	300 C	Opp	57				Furnished
								272MCDAX-*3 (27)	300 C	Opp	69				Furnished
								272MDDAX-*3 (28)	300 C	Opp	83				Furnished
								272MGDAX-*3 (29)	300 C	Opp	99				Furnished
								272MKDAX-*3 (30)	300 C	Opp	110				Furnished
								272MMDAX-*3 (31)	300 C	Opp	123				Furnished
								272MPDAX-*3 (32)	300 C	Opp	138				Furnished
								272MSDAX-*3 (33)	300 C	Opp	154				Furnished

ONE SPEED - TWO GEAR - POWERSHIFT (AIR)

885XBDAX-*5 (5)	500 I	Opp	57				Furnished								
885XGDAX-*5 (9)	500 I	Opp	73				Furnished								
885XMDAX-*5 (6)	500 I	Opp	101				Furnished								

ONE SPEED - FORWARD & REVERSE

348ZFDAX-*5 (34)	200 I	Opp	79	83			Furnished	340SFDAX-*5 (34)	200 I	Opp	79	83			Furnished
863XBDAX-*5	500 I	Opp	57	70			Furnished								

GEARED ADAPTERS

628ZDAX-5DA	250 I	Eng					Furnished	626ZDAX-3DA	250 I	Eng			7-A-062		Furnished
								630ZDAX-3DA	250 I	Eng			7-A-062		Furnished
								645ZDAX-3DA	250 I	Eng			7-A-062		Furnished

† I = Intermittent Torque Only - De-rate Torque Rating 30% for Continuous Duty.

C = Continuous or Intermittent Torque - No need to De-Rate Torque Rating.

IMPORTANT: Refer to the back of this transmission section and read all notes associated with this application page. Some notes may affect the proper PTO selection.

CAUTION: Do not use geared adapters with 442 A and C ratios.

(5) Input Gear Part No. 5-P-1120
(6) Input Gear Part No. 5-P-1121
(9) Input Gear Part No. 5-P-1174
(18) Input Gear Part No. 5-P-1511-13X
(19) Input Gear Part No. 5-P-1511-14X
(20) Input Gear Part No. 5-P-1511-15X

(21) Input Gear Part No. 5-P-1511-16X
(22) Input Gear Part No. 5-P-1511-17X
(23) Input Gear Part No. 5-P-1511-18X
(24) Input Gear Part No. 5-P-1511-19X
(25) Input Gear Part No. 5-P-1511-1X
(26) Input Gear Part No. 5-p-1511-2X

(27) Input Gear Part No. 5-P-1511-3X
(28) Input Gear Part No. 5-P-1511-4X
(29) Input Gear Part No. 5-P-1511-5X
(30) Input Gear Part No. 5-P-1511-6X
(31) Input Gear Part No. 5-P-1511-7X
(32) Input Gear Part No. 5-P-1511-8X

(33) Input Gear Part No. 5-P-1511-9X
(34) Input Gear Part No. 5-P-634

T2050 T2060 T2070 T2070-A (Front Box) T2070-B (Front Box) T2070-F T2080 T2080-B (Front Box)	T305 T306 T307 T307M (Front Box) T308 T308M (Front Box) TX2060 X2060
--	---

LEFT SIDE ONLY	RIGHT SIDE ONLY
TRANSMISSION GEAR DATA: L.S. 08-BOLT Opening Gear FORWARD of Centerline 54 Teeth - SPUR PITCH LINE TO APERTURE FACE: 0.8100" (20.5700MM)	TRANSMISSION GEAR DATA: R.S. 06-BOLT Opening Gear FORWARD of Centerline 54 Teeth - SPUR PITCH LINE TO APERTURE FACE: 1.0850" (27.5600MM)

CAUTION: Application Approval Required for PTO Output Shaft Speeds Above 2500 RPM

PTO Model	Torq I / C †	Dir Rot	Engine %		Filler Block	Adapter Assy	Stud Kit	PTO Model	Torq I / C †	Dir Rot	Engine %		Filler Block	Adapter Assy	Stud Kit
			Fwd	Rev							Fwd	Rev			

ONE SPEED - TWO GEAR - MECHANICAL SHIFT

221ZCDAX-*5	250 I	Opp	81			328564X	Furnished	221XCDAX-*3	250 I	Opp	81				Furnished
221ZEDAX-*5	250 I	Opp	90			328564X	Furnished	221XEDAX-*3	250 I	Opp	90				Furnished
489ZADAX-*5 (8)	250 I	Opp	71				Furnished	442ZADAX-*3 (8)	250 I	Opp	71		7-A-062		Furnished
489ZCDAX-*5 (9)	250 I	Opp	90				Furnished	442ZCDAX-*3 (9)	250 I	Opp	90		7-A-062		Furnished
489ZFDAX-*5 (2)	250 I	Opp	112				Furnished	442ZFDAX-*3 (2)	250 I	Opp	112		7-A-062		Furnished
489ZHDAX-*5 (13)	250 I	Opp	130				Furnished	442ZHDAX-*3 (13)	250 I	Opp	130		7-A-062		Furnished
489ZLDAX-*5 (1)	250 I	Opp	144				Furnished	442ZLDAX-*3 (1)	250 I	Opp	144		7-A-062		Furnished
489ZQDAX-*5 (1)	225 I	Opp	156				Furnished	442ZQDAX-*3 (1)	225 I	Opp	156		7-A-062		Furnished
489ZRDAX-*5 (1)	225 I	Opp	180				Furnished	442ZRDAX-*3 (1)	225 I	Opp	180		7-A-062		Furnished
489ZSDAX-*5 (1)	200 I	Opp	214				Furnished	442ZSDAX-*3 (1)	200 I	Opp	214		7-A-062		Furnished
489ZUDAX-*5 (1)	195 I	Opp	255				Furnished	442ZUDAX-*3 (1)	195 I	Opp	255		7-A-062		Furnished
489ZWDAX-*5 (1)	175 I	Opp	301				Furnished	442ZWDAX-*3 (1)	175 I	Opp	301		7-A-062		Furnished
489ZXDAX-*5 (1)	140 I	Opp	356				Furnished	442ZXDAX-*3 (1)	140 I	Opp	356		7-A-062		Furnished
680ZFDAX-*5 (10)	375 I	Opp	112				Furnished	660ZFDAX-*3 (10)	375 I	Opp	112		7-A-062		Furnished
680ZQDAX-*5 (11)	375 I	Opp	156				Furnished	660ZQDAX-*3 (11)	375 I	Opp	156		7-A-062		Furnished
680ZSDAX-*5 (12)	325 I	Opp	214				Furnished	660ZSDAX-*3 (12)	325 I	Opp	214		7-A-062		Furnished
823XBDAX-*5 (33)	500 I	Opp	73				Furnished								
823XMDAX-*5 (34)	500 I	Opp	129				Furnished								
823XRDAX-*5 (35)	400 I	Opp	178				Furnished								
880XBDAX-*5 (3)	500 I	Opp	73				Furnished								
880XGDAX-*5 (7)	500 I	Opp	94				Furnished								
880XMDAX-*5 (4)	500 I	Opp	129				Furnished								
880XRDAX-*5 (5)	400 I	Opp	178				Furnished								
880XTDAX-*5 (6)	350 I	Opp	230				Furnished								

ONE SPEED - TWO GEAR POWERSHIFT (AIR OR HYDRAULIC)

282XBDAX-*5 (15)	300 C	Opp	74				Furnished	272XADAX-*3 (24)	300 C	Opp	60				Furnished
282XCDAX-*5 (16)	300 C	Opp	89				Furnished	272XBDAX-*3 (25)	300 C	Opp	74				Furnished
282XDDAX-*5 (17)	300 C	Opp	107				Furnished	272XCDAX-*3 (26)	300 C	Opp	89				Furnished
282XGDAX-*5 (18)	300 C	Opp	127				Furnished	272XDDAX-*3 (14)	300 C	Opp	107				Furnished
282XKDAX-*5 (19)	300 C	Opp	142				Furnished	272XGDAX-*3 (27)	300 C	Opp	127				Furnished
282XMDAX-*5 (20)	300 C	Opp	158				Furnished	272XKDAX-*3 (28)	300 C	Opp	142				Furnished

† I = Intermittent Torque Only - De-rate Torque Rating 30% for Continuous Duty.

C = Continuous or Intermittent Torque - No need to De-Rate Torque Rating.

IMPORTANT: Refer to the back of this transmission section and read all notes associated with this application page. Some notes may affect the proper PTO selection.

CAUTION: 272*S Ratio - Contact Chelsea Engineering for Application approval for continuous duty applications.

CCAUTION: Do not use geared adapters with 442 A and C ratios.

- (1) Input Gear Part No. 5-P-1037
- (2) Input Gear Part No. 5-P-1085
- (3) Input Gear Part No. 5-P-1120
- (4) Input Gear Part No. 5-P-1121
- (5) Input Gear Part No. 5-P-1122
- (6) Input Gear Part No. 5-P-1123

- (7) Input Gear Part No. 5-P-1174
- (8) Input Gear Part No. 5-P-1284
- (9) Input Gear Part No. 5-P-1291
- (10) Input Gear Part No. 5-P-1330
- (11) Input Gear Part No. 5-P-1331
- (12) Input Gear Part No. 5-P-1332

- (13) Input Gear Part No. 5-P-1365
- (14) Input Gear Part No. 5-P-1510-4X
- (15) Input Gear Part No. 5-P-1511-11X
- (16) Input Gear Part No. 5-P-1511-12X
- (17) Input Gear Part No. 5-P-1511-13X
- (18) Input Gear Part No. 5-P-1511-14X

- (19) Input Gear Part No. 5-P-1511-15X
- (20) Input Gear Part No. 5-P-1511-16X
- (24) Input Gear Part No. 5-P-1511-1X
- (25) Input Gear Part No. 5-p-1511-2X
- (26) Input Gear Part No. 5-P-1511-3X
- (27) Input Gear Part No. 5-P-1511-5X

- (28) Input Gear Part No. 5-P-1511-6X
- (33) Input Gear Part No. 5-P-636
- (34) Input Gear Part No. 5-P-637
- (35) Input Gear Part No. 5-P-808

MAK-25

MACK

CHELSEA®

T2050	T305
T2060	T306
T2070	T307
T2070-A (Front Box)	T307M (Front Box)
T2070-B (Front Box)	T308
T2070-F	T308M (Front Box)
T2080	TX2060
T2080-B (Front Box)	X2060

LEFT SIDE ONLY

RIGHT SIDE ONLY

TRANSMISSION GEAR DATA:

L.S. 08-BOLT Opening Gear FORWARD of Centerline
54 Teeth - SPURPITCH LINE TO APERTURE FACE:
0.8100" (20.5700MM)

TRANSMISSION GEAR DATA:

R.S. 06-BOLT Opening Gear FORWARD of Centerline
54 Teeth - SPURPITCH LINE TO APERTURE FACE:
1.0850" (27.5600MM)

CAUTION: Application Approval Required for PTO Output Shaft Speeds Above 2500 RPM

PTO Model	Torq I / C †	Dir Rot	Engine %		Filler Block	Adapter Assy	Stud Kit	PTO Model	Torq I / C †	Dir Rot	Engine %		Filler Block	Adapter Assy	Stud Kit
			Fwd	Rev							Fwd	Rev			
ONE SPEED - TWO GEAR POWERSHIFT (AIR OR HYDRAULIC)															
282XPDAX-*5 (21)	283 C	Opp	177				Furnished	272XMDAX-*3 (29)	300 C	Opp	158				Furnished
282XSDAX-*5 (22)	253 C	Opp	198				Furnished	272XPDAX-*3 (30)	283 C	Opp	177				Furnished
282XTDAX-*5 (23)	226 C	Opp	221				Furnished	272XSDAX-*3 (31)	253 C	Opp	198				Furnished
ONE SPEED - POWERSHIFT LOW PROFILE (AIR OR HYDRAULIC)															
								272MADAX-*3 (24)	300 C	Opp	60				Furnished
								272MBDAX-*3 (25)	300 C	Opp	74				Furnished
								272MCDAX-*3 (26)	300 C	Opp	89				Furnished
								272MDAX-*3 (14)	300 C	Opp	107				Furnished
								272MGDAX-*3 (27)	300 C	Opp	127				Furnished
								272MKDAX-*3 (28)	300 C	Opp	142				Furnished
								272MMDAX-*3 (29)	300 C	Opp	158				Furnished
								272MPDAX-*3 (30)	283 C	Opp	177				Furnished
								272MSDAX-*3 (31)	253 C	Opp	198				Furnished
ONE SPEED - TWO GEAR - POWERSHIFT (AIR)															
885XBDAX-*5 (3)	500 I	Opp	73				Furnished								
885XGDAX-*5 (7)	500 I	Opp	94				Furnished								
885XMDAX-*5 (4)	500 I	Opp	129				Furnished								
ONE SPEED - FORWARD & REVERSE															
348ZFDAX-*5 (32)	200 I	Opp	102	107			Furnished	340SFDAX-*5 (32)	200 I	Opp	102	107			Furnished
863XBDAX-*5	500 I	Opp	73	90			Furnished								
GEARED ADAPTERS															
628ZDAX-3DA	250 I	Eng					Furnished	626ZDAX-3DA	250 I	Eng			7-A-062		Furnished
								630ZDAX-3DA	250 I	Eng			7-A-062		Furnished
								645ZDAX-3DA	250 I	Eng			7-A-062		Furnished

† I = Intermittent Torque Only - De-rate Torque Rating 30% for Continuous Duty.

C = Continuous or Intermittent Torque - No need to De-Rate Torque Rating.

IMPORTANT: Refer to the back of this transmission section and read all notes associated with this application page.
Some notes may affect the proper PTO selection.

CAUTION: 272*S Ratio - Contact Chelsea Engineering for Application approval for continuous duty applications.

CAUTION: Do not use geared adapters with 442 A and C ratios.

(3) Input Gear Part No. 5-P-1120

(4) Input Gear Part No. 5-P-1121

(7) Input Gear Part No. 5-P-1174

(14) Input Gear Part No. 5-P-1510-4X

(21) Input Gear Part No. 5-P-1511-17X

(22) Input Gear Part No. 5-P-1511-18X

(23) Input Gear Part No. 5-P-1511-19X

(24) Input Gear Part No. 5-P-1511-1X

(25) Input Gear Part No. 5-P-1511-2X

(26) Input Gear Part No. 5-P-1511-3X

(27) Input Gear Part No. 5-P-1511-5X

(28) Input Gear Part No. 5-P-1511-6X

(29) Input Gear Part No. 5-P-1511-7X

(30) Input Gear Part No. 5-P-1511-8X

(31) Input Gear Part No. 5-P-1511-9X

(32) Input Gear Part No. 5-P-634

T2070-A (Rear Box) T2070-B (Rear Box) T2070-D (Rear Box) T2080-B (Rear Box) T2080-D (Rear Box) T307M (Rear Box) T308M (Rear Box) TM308M (Rear Box)	TM309M (Rear Box)
---	-------------------

LEFT SIDE ONLY	RIGHT SIDE ONLY
TRANSMISSION GEAR DATA: L.S. 08-BOLT Opening Gear FORWARD of Centerline 49 Teeth - SPUR PITCH LINE TO APERTURE FACE: 0.6670" (16.9400MM)	TRANSMISSION GEAR DATA: R.S. 06-BOLT Opening Gear FORWARD of Centerline 49 Teeth - SPUR PITCH LINE TO APERTURE FACE: 1.0550" (26.8000MM)

CAUTION: Application Approval Required for PTO Output Shaft Speeds Above 2500 RPM

PTO Model	Torq I / C †	Dir Rot	Engine %		Filler Block	Adapter Assy	Stud Kit	PTO Model	Torq I / C †	Dir Rot	Engine %		Filler Block	Adapter Assy	Stud Kit
			Fwd	Rev							Fwd	Rev			

ONE SPEED - TWO GEAR - MECHANICAL SHIFT

221ZCDAX-*5	250 I	Opp	90		7-A-062(P)	328564X	Furnished	221XCDAX-*3	250 I	Opp	90		7-A-032		Furnished
221ZEDAX-*5	250 I	Opp	100		7-A-062(P)	328564X	Furnished	221XEDAX-*3	250 I	Opp	100		7-A-032		Furnished
489ZADAX-*5 (8)	250 I	Opp	78		8-A-062		328170-190X	442ZADAX-*3 (8)	250 I	Opp	78		7-A-140		Furnished
489ZCDAX-*5 (9)	250 I	Opp	100		8-A-062		328170-190X	442ZCDAX-*3 (9)	250 I	Opp	100		7-A-140		Furnished
489ZFDAX-*5 (2)	250 I	Opp	124		8-A-062		328170-190X	442ZFDAX-*3 (2)	250 I	Opp	124		7-A-140		Furnished
489ZHDAX-*5 (13)	250 I	Opp	144		8-A-062		328170-190X	442ZHDAX-*3 (13)	250 I	Opp	144		7-A-140		Furnished
489ZLDAX-*5 (1)	250 I	Opp	161		8-A-062		328170-190X	442ZLDAX-*3 (1)	250 I	Opp	161		7-A-140		Furnished
489ZQDAX-*5 (1)	225 I	Opp	173		8-A-062		328170-190X	442ZQDAX-*3 (1)	225 I	Opp	173		7-A-140		Furnished
489ZRDAX-*5 (1)	225 I	Opp	200		8-A-062		328170-190X	442ZRDAX-*3 (1)	225 I	Opp	200		7-A-140		Furnished
489ZSDAX-*5 (1)	200 I	Opp	238		8-A-062		328170-190X	442ZSDAX-*3 (1)	200 I	Opp	238		7-A-140		Furnished
489ZUDAX-*5 (1)	195 I	Opp	284		8-A-062		328170-190X	442ZUDAX-*3 (1)	195 I	Opp	284		7-A-140		Furnished
489ZWDAX-*5 (1)	175 I	Opp	334		8-A-062		328170-190X	442ZWDAX-*3 (1)	175 I	Opp	334		7-A-140		Furnished
489ZXDAX-*5 (1)	140 I	Opp	395		8-A-062		328170-190X	442ZXDAX-*3 (1)	140 I	Opp	395		7-A-140		Furnished
680ZFDAX-*5 (10)	375 I	Opp	124		8-A-062		328170-190X	660ZFDAX-*3 (10)	375 I	Opp	124		7-A-140		Furnished
680ZQDAX-*5 (11)	375 I	Opp	173		8-A-062		328170-190X	660ZQDAX-*3 (11)	375 I	Opp	173		7-A-140		Furnished
680ZSDAX-*5 (12)	325 I	Opp	238		8-A-062		328170-190X	660ZSDAX-*3 (12)	325 I	Opp	238		7-A-140		Furnished
823XBDAX-*5 (32)	500 I	Opp	81				Furnished								
823XMDAX-*5 (33)	500 I	Opp	143				Furnished								
823XRDAX-*5 (34)	400 I	Opp	198				Furnished								
880XBDAX-*5 (3)	500 I	Opp	81				Furnished								
880XGDAX-*5 (7)	500 I	Opp	104				Furnished								
880XMDAX-*5 (4)	500 I	Opp	143				Furnished								
880XRDAX-*5 (5)	400 I	Opp	198				Furnished								
880XTDAX-*5 (6)	350 I	Opp	255				Furnished								

ONE SPEED - TWO GEAR POWERSHIFT (AIR OR HYDRAULIC)

282XBDAX-*5 (14)	300 C	Opp	82		8-A-062		328170-190X	272XADAX-*3 (23)	300 C	Opp	67		7-A-032		Furnished
282XCDAX-*5 (15)	300 C	Opp	99		8-A-062		328170-190X	272XBDAX-*3 (24)	300 C	Opp	82		7-A-032		Furnished
282XDDAX-*5 (16)	300 C	Opp	118		8-A-062		328170-190X	272XCDAX-*3 (25)	300 C	Opp	99		7-A-032		Furnished
282XGDAX-*5 (17)	300 C	Opp	141		8-A-062		328170-190X	272XGDAX-*3 (26)	300 C	Opp	141		7-A-032		Furnished
282XKDAX-*5 (18)	300 C	Opp	157		8-A-062		328170-190X	272XKDAX-*3 (27)	300 C	Opp	157		7-A-032		Furnished
282XMDAX-*5 (19)	284 C	Opp	176		8-A-062		328170-190X	272XMDAX-*3 (28)	284 C	Opp	176		7-A-032		Furnished

† I = Intermittent Torque Only - De-rate Torque Rating 30% for Continuous Duty.

C = Continuous or Intermittent Torque - No need to De-Rate Torque Rating.

IMPORTANT: Refer to the back of this transmission section and read all notes associated with this application page. Some notes may affect the proper PTO selection.

CAUTION: 272*S Ratio - Contact Chelsea Engineering for application approval for continuous duty applications.

CAUTION: Do not use geared adapters with 442 A and C ratios.

- (1) Input Gear Part No. 5-P-1037
- (2) Input Gear Part No. 5-P-1085
- (3) Input Gear Part No. 5-P-1120
- (4) Input Gear Part No. 5-P-1121
- (5) Input Gear Part No. 5-P-1122
- (6) Input Gear Part No. 5-P-1123

- (7) Input Gear Part No. 5-P-1174
- (8) Input Gear Part No. 5-P-1284
- (9) Input Gear Part No. 5-P-1291
- (10) Input Gear Part No. 5-P-1330
- (11) Input Gear Part No. 5-P-1331
- (12) Input Gear Part No. 5-P-1332

- (13) Input Gear Part No. 5-P-1365
- (14) Input Gear Part No. 5-P-1511-11X
- (15) Input Gear Part No. 5-P-1511-12X
- (16) Input Gear Part No. 5-P-1511-13X
- (17) Input Gear Part No. 5-P-1511-14X
- (18) Input Gear Part No. 5-P-1511-15X

- (19) Input Gear Part No. 5-P-1511-16X
- (23) Input Gear Part No. 5-P-1511-1X
- (24) Input Gear Part No. 5-p-1511-2X
- (25) Input Gear Part No. 5-P-1511-3X
- (26) Input Gear Part No. 5-P-1511-5X
- (27) Input Gear Part No. 5-P-1511-6X

- (28) Input Gear Part No. 5-P-1511-7X
- (32) Input Gear Part No. 5-P-636
- (33) Input Gear Part No. 5-P-637
- (34) Input Gear Part No. 5-P-808

MAK-26

MACK

CHELSEA®

T2070-A (Rear Box) T2070-B (Rear Box) T2070-D (Rear Box) T2080-B (Rear Box) T2080-D (Rear Box) T307M (Rear Box) T308M (Rear Box) TM308M (Rear Box)	TM309M (Rear Box)
---	-------------------

LEFT SIDE ONLY	RIGHT SIDE ONLY
TRANSMISSION GEAR DATA: L.S. 08-BOLT Opening Gear FORWARD of Centerline 49 Teeth - SPUR PITCH LINE TO APERTURE FACE: 0.6670" (16.9400MM)	TRANSMISSION GEAR DATA: R.S. 06-BOLT Opening Gear FORWARD of Centerline 49 Teeth - SPUR PITCH LINE TO APERTURE FACE: 1.0550" (26.8000MM)

CAUTION: Application Approval Required for PTO Output Shaft Speeds Above 2500 RPM

PTO Model	Torq I / C †	Dir Rot	Engine %		Filler Block	Adapter Assy	Stud Kit	PTO Model	Torq I / C †	Dir Rot	Engine %		Filler Block	Adapter Assy	Stud Kit
			Fwd	Rev							Fwd	Rev			
ONE SPEED - TWO GEAR POWERSHIFT (AIR OR HYDRAULIC)															
282XPDAX-*5 (20)	254 C	Opp	197		8-A-062		328170-190X	272XPDAX-*3 (29)	254 C	Opp	197		7-A-032		Furnished
282XSDAX-*5 (21)	227 C	Opp	200		8-A-062		328170-190X	272XSDAX-*3 (30)	227 C	Opp	220		7-A-032		Furnished
282XTDAX-*5 (22)	203 C	Opp	246		8-A-062		328170-190X								
ONE SPEED - POWERSHIFT LOW PROFILE (AIR OR HYDRAULIC)															
								272MADAX-*3 (23)	300 C	Opp	67		7-A-032		Furnished
								272MBDAX-*3 (24)	300 C	Opp	82		7-A-032		Furnished
								272MCDAX-*3 (25)	300 C	Opp	99		7-A-032		Furnished
								272MGDAX-*3 (26)	300 C	Opp	141		7-A-032		Furnished
								272MKDAX-*3 (27)	300 C	Opp	157		7-A-032		Furnished
								272MMDAX-*3 (28)	284 C	Opp	176		7-A-032		Furnished
								272MPDAX-*3 (29)	254 C	Opp	197		7-A-032		Furnished
								272MSDAX-*3 (30)	227 C	Opp	220		7-A-032		Furnished
ONE SPEED - TWO GEAR - POWERSHIFT (AIR)															
885XBDAX-*5 (3)	500 I	Opp	81				Furnished								
885XGDAX-*5 (7)	500 I	Opp	104				Furnished								
885XMDAX-*5 (4)	500 I	Opp	143				Furnished								
ONE SPEED - FORWARD & REVERSE															
348ZFDAX-*5 (31)	200 I	Opp	113	119	8-A-062		328170-190X	340SFDAX-*5 (31)	200 I	Opp	113	119	7-A-062		Furnished
863XBDAX-*5	500 I	Opp	81	100			Furnished								
GEARED ADAPTERS															
628ZDAX-5DA	250 I	Eng					Furnished	626ZDAX-3DA	250 I	Eng			7-A-062		Furnished
645ZDAX-3DA	250 I	Eng			7-A-062		Furnished	630ZDAX-3DA	250 I	Eng			7-A-062		Furnished

† I = Intermittent Torque Only - De-rate Torque Rating 30% for Continuous Duty.

C = Continuous or Intermittent Torque - No need to De-Rate Torque Rating.

IMPORTANT: Refer to the back of this transmission section and read all notes associated with this application page. Some notes may affect the proper PTO selection.

CAUTION: 272*S Ratio - Contact Chelsea Engineering for application approval for continuous duty applications.

CAUTION: Do not use geared adapters with 442 A and C ratios.

- (3) Input Gear Part No. 5-P-1120
- (4) Input Gear Part No. 5-P-1121
- (7) Input Gear Part No. 5-P-1174
- (20) Input Gear Part No. 5-P-1511-17X
- (21) Input Gear Part No. 5-P-1511-18X
- (22) Input Gear Part No. 5-P-1511-19X

- (23) Input Gear Part No. 5-P-1511-1X
- (24) Input Gear Part No. 5-p-1511-2X
- (25) Input Gear Part No. 5-P-1511-3X
- (26) Input Gear Part No. 5-P-1511-5X
- (27) Input Gear Part No. 5-P-1511-6X
- (28) Input Gear Part No. 5-P-1511-7X

- (29) Input Gear Part No. 5-P-1511-8X
- (30) Input Gear Part No. 5-P-1511-9X
- (31) Input Gear Part No. 5-P-634

T2180 (Rear Box)
T2180-B (Rear Box)
T318LR (Rear Box)
T318L (Rear Box)
T318LR21 (Rear Box)
T318L21 (Rear Box)
T310-M (Rear Box)
T310-MLR (Rear Box)

T310ME (Rear box, same as T310M, output flange extended for rear mount PTO)
T318 (Rear Box)

LEFT SIDE ONLY

RIGHT SIDE ONLY

TRANSMISSION GEAR DATA:
L.S. 08-BOLT Opening Gear FORWARD of Centerline
49 Teeth - SPUR
PITCH LINE TO APERTURE FACE:
0.6670" (16.9400MM)

TRANSMISSION GEAR DATA:
R.S. 06-BOLT Opening Gear FORWARD of Centerline
49 Teeth - SPUR
PITCH LINE TO APERTURE FACE:
1.0550" (26.8000MM)

CAUTION: Application Approval Required for PTO Output Shaft Speeds Above 2500 RPM

PTO Model	Torq I / C †	Dir Rot	Engine %		Filler Block	Adapter Assy	Stud Kit	PTO Model	Torq I / C †	Dir Rot	Engine %		Filler Block	Adapter Assy	Stud Kit
			Fwd	Rev							Fwd	Rev			

ONE SPEED - TWO GEAR - MECHANICAL SHIFT

221ZCDAX-*5	250 I	Opp	54		7-A-062(P)	328564X	Furnished	221XCDAX-*3	250 I	Opp	54		7-A-032		Furnished
221ZEDAX-*5	250 I	Opp	59		7-A-062(P)	328564X	Furnished	221XEDAX-*3	250 I	Opp	59		7-A-032		Furnished
489ZADAX-*5 (8)	250 I	Opp	47		8-A-062		328170-190X	442ZADAX-*3 (8)	250 I	Opp	47		7-A-140		Furnished
489ZCDAX-*5 (9)	250 I	Opp	60		8-A-062		328170-190X	442ZCDAX-*3 (9)	250 I	Opp	60		7-A-140		Furnished
489ZFDAX-*5 (2)	250 I	Opp	74		8-A-062		328170-190X	442ZFDAX-*3 (2)	250 I	Opp	74		7-A-140		Furnished
489ZHDAX-*5 (13)	250 I	Opp	86		8-A-062		328170-190X	442ZHDAX-*3 (13)	250 I	Opp	86		7-A-140		Furnished
489ZLDAX-*5 (1)	250 I	Opp	96		8-A-062		328170-190X	442ZLDAX-*3 (1)	250 I	Opp	96		7-A-140		Furnished
489ZQDAX-*5 (1)	225 I	Opp	103		8-A-062		328170-190X	442ZQDAX-*3 (1)	225 I	Opp	103		7-A-140		Furnished
489ZRDAX-*5 (1)	225 I	Opp	120		8-A-062		328170-190X	442ZRDAX-*3 (1)	225 I	Opp	120		7-A-140		Furnished
489ZSDAX-*5 (1)	200 I	Opp	142		8-A-062		328170-190X	442ZSDAX-*3 (1)	200 I	Opp	142		7-A-140		Furnished
489ZUDAX-*5 (1)	195 I	Opp	169		8-A-062		328170-190X	442ZUDAX-*3 (1)	195 I	Opp	169		7-A-140		Furnished
489ZWDAX-*5 (1)	175 I	Opp	199		8-A-062		328170-190X	442ZWDAX-*3 (1)	175 I	Opp	199		7-A-140		Furnished
489ZXDAX-*5 (1)	140 I	Opp	236		8-A-062		328170-190X	442ZXDAX-*3 (1)	140 I	Opp	236		7-A-140		Furnished
680ZFDAX-*5 (10)	375 I	Opp	74		8-A-062		328170-190X	660ZFDAX-*3 (10)	375 I	Opp	74		7-A-140		Furnished
680ZQDAX-*5 (11)	375 I	Opp	103		8-A-062		328170-190X	660ZQDAX-*3 (11)	375 I	Opp	103		7-A-140		Furnished
680ZSDAX-*5 (12)	325 I	Opp	142		8-A-062		328170-190X	660ZSDAX-*3 (12)	325 I	Opp	142		7-A-140		Furnished
823XBDAX-*5	500 I	Opp	48				Furnished								
823XMDAX-*5 (33)	500 I	Opp	86				Furnished								
823XRDAX-*5 (34)	400 I	Opp	118				Furnished								
880XBDAX-*5 (3)	500 I	Opp	48				Furnished								
880XGDAX-*5 (7)	500 I	Opp	62				Furnished								
880XMDAX-*5 (4)	500 I	Opp	86				Furnished								
880XRDAX-*5 (5)	400 I	Opp	118				Furnished								
880XTDAX-*5 (6)	350 I	Opp	152				Furnished								

ONE SPEED - TWO GEAR POWERSHIFT (AIR OR HYDRAULIC)

282XBDAX-*5 (15)	300 C	Opp	49		8-A-062		Furnished	272XADAX-*3 (24)	300 C	Opp	40		7-A-032		Furnished
282XCDAX-*5 (16)	300 C	Opp	59		8-A-062		Furnished	272XCDAX-*3 (26)	300 C	Opp	59		7-A-032		Furnished
282XDDAX-*5 (17)	300 C	Opp	71		8-A-062		Furnished	272XDAJX-*3 (14)	300 C	Opp	71		7-A-032		Furnished
282XGDAX-*5 (18)	300 C	Opp	84		8-A-062		Furnished	272XGDAX-*3 (27)	300 C	Opp	84		7-A-032		Furnished
282XKDAX-*5 (19)	300 C	Opp	94		8-A-062		Furnished	272XKDAX-*3 (28)	300 C	Opp	94		7-A-032		Furnished
282XMDAX-*5 (20)	300 C	Opp	105		8-A-062		Furnished	272XMDAX-*3 (29)	300 C	Opp	105		7-A-032		Furnished

† I = Intermittent Torque Only - De-rate Torque Rating 30% for Continuous Duty.

C = Continuous or Intermittent Torque - No need to De-Rate Torque Rating.

IMPORTANT: Refer to the back of this transmission section and read all notes associated with this application page. Some notes may affect the proper PTO selection.

CAUTION: Do not use geared adapters with 442 A and C ratios.

CAUTION: Mack Does Not approve PTO operations with the Range Selector in the "HI" position. Damage to the transmission synchronizers may occur. Refer to Mack operator's manual for correct PTO operation.

- (1) Input Gear Part No. 5-P-1037
- (2) Input Gear Part No. 5-P-1085
- (3) Input Gear Part No. 5-P-1120
- (4) Input Gear Part No. 5-P-1121
- (5) Input Gear Part No. 5-P-1122
- (6) Input Gear Part No. 5-P-1123

- (7) Input Gear Part No. 5-P-1174
- (8) Input Gear Part No. 5-P-1284
- (9) Input Gear Part No. 5-P-1291
- (10) Input Gear Part No. 5-P-1330
- (11) Input Gear Part No. 5-P-1331
- (12) Input Gear Part No. 5-P-1332

- (13) Input Gear Part No. 5-P-1365
- (14) Input Gear Part No. 5-P-1510-4X
- (15) Input Gear Part No. 5-P-1511-11X
- (16) Input Gear Part No. 5-P-1511-12X
- (17) Input Gear Part No. 5-P-1511-13X
- (18) Input Gear Part No. 5-P-1511-14X

- (19) Input Gear Part No. 5-P-1511-15X
- (20) Input Gear Part No. 5-P-1511-16X
- (24) Input Gear Part No. 5-P-1511-1X
- (26) Input Gear Part No. 5-P-1511-3X
- (27) Input Gear Part No. 5-P-1511-5X
- (28) Input Gear Part No. 5-P-1511-6X

- (29) Input Gear Part No. 5-P-1511-7X
- (33) Input Gear Part No. 5-P-637
- (34) Input Gear Part No. 5-P-808

MAK-27

MACK

CHELSEA®

T2180 (Rear Box) T2180-B (Rear Box) T318LR (Rear Box) T318L (Rear Box) T318LR21 (Rear Box) T318L21 (Rear Box) T310-M (Rear Box) T310-MLR (Rear Box)	T310ME (Rear box, same as T310M, output flange extended for rear mount PTO) T318 (Rear Box)
--	--

LEFT SIDE ONLY	RIGHT SIDE ONLY
TRANSMISSION GEAR DATA: L.S. 08-BOLT Opening Gear FORWARD of Centerline 49 Teeth - SPUR PITCH LINE TO APERTURE FACE: 0.6670" (16.9400MM)	TRANSMISSION GEAR DATA: R.S. 06-BOLT Opening Gear FORWARD of Centerline 49 Teeth - SPUR PITCH LINE TO APERTURE FACE: 1.0550" (26.8000MM)

CAUTION: Application Approval Required for PTO Output Shaft Speeds Above 2500 RPM

PTO Model	Torq I / C †	Dir Rot	Engine %		Filler Block	Adapter Assy	Stud Kit	PTO Model	Torq I / C †	Dir Rot	Engine %		Filler Block	Adapter Assy	Stud Kit
			Fwd	Rev							Fwd	Rev			
ONE SPEED - TWO GEAR POWERSHIFT (AIR OR HYDRAULIC)															
282XPDAX-*5 (21)	300 C	Opp	117		8-A-062		Furnished	272XPDAX-*3 (30)	300 C	Opp	117		7-A-032		Furnished
282XSDAX-*5 (22)	300 C	Opp	131		8-A-062		Furnished	272XSDAX-*3 (31)	300 C	Opp	131		7-A-032		Furnished
282XTDAX-*5 (23)	300 C	Opp	147		8-A-062		Furnished								
ONE SPEED - POWERSHIFT LOW PROFILE (AIR OR HYDRAULIC)															
								272MADAX-*3 (24)	300 C	Opp	40		7-A-032		Furnished
								272MBDAX-*3 (25)	300 C	Opp	49		7-A-032		Furnished
								272MCDAX-*3 (26)	300 C	Opp	59		7-A-032		Furnished
								272MDAJX-*3 (14)	300 C	Opp	71		7-A-032		Furnished
								272MGDAX-*3 (27)	300 C	Opp	84		7-A-032		Furnished
								272MKDAX-*3 (28)	300 C	Opp	94		7-A-032		Furnished
								272MMDAX-*3 (29)	300 C	Opp	105		7-A-032		Furnished
								272MPDAX-*3 (30)	300 C	Opp	117		7-A-032		Furnished
								272MSDAX-*3 (31)	300 C	Opp	131		7-A-032		Furnished
ONE SPEED - TWO GEAR - POWERSHIFT (AIR)															
885XBDAX-*5 (3)	500 I	Opp	48				Furnished								
885XGDAX-*5 (7)	500 I	Opp	62				Furnished								
885XMDAX-*5 (4)	500 I	Opp	86				Furnished								
ONE SPEED - FORWARD & REVERSE															
348ZFDAX-*5 (32)	200 I	Opp	68	71	8-A-062		328170-190X	340SFDAX-*5 (32)	200 I	Opp	68	71	7-A-062		Furnished
863XBDAX-*5	500 I	Opp	48	60			Furnished								

† I = Intermittent Torque Only - De-rate Torque Rating 30% for Continuous Duty.

C = Continuous or Intermittent Torque - No need to De-Rate Torque Rating.

IMPORTANT: Refer to the back of this transmission section and read all notes associated with this application page. Some notes may affect the proper PTO selection.

CAUTION: Do not use geared adapters with 442 A and C ratios.

CAUTION: Mack Does Not approve PTO operations with the Range Selector in the "HI" position. Damage to the transmission synchronizers may occur. Refer to Mack operator's manual for correct PTO operation.

- | | | |
|---------------------------------------|---------------------------------------|--------------------------------------|
| (3) Input Gear Part No. 5-P-1120 | (23) Input Gear Part No. 5-P-1511-19X | (29) Input Gear Part No. 5-P-1511-7X |
| (4) Input Gear Part No. 5-P-1121 | (24) Input Gear Part No. 5-P-1511-1X | (30) Input Gear Part No. 5-P-1511-8X |
| (7) Input Gear Part No. 5-P-1174 | (25) Input Gear Part No. 5-p-1511-2X | (31) Input Gear Part No. 5-P-1511-9X |
| (14) Input Gear Part No. 5-P-1510-4X | (26) Input Gear Part No. 5-P-1511-3X | (32) Input Gear Part No. 5-P-634 |
| (21) Input Gear Part No. 5-P-1511-17X | (27) Input Gear Part No. 5-P-1511-5X | |
| (22) Input Gear Part No. 5-P-1511-18X | (28) Input Gear Part No. 5-P-1511-6X | |

CHELSEA®

MACK

MAK-27

T2180 (Rear Box)
T2180-B (Rear Box)
T318LR (Rear Box)
T318L (Rear Box)
T318LR21 (Rear Box)
T318L21 (Rear Box)
T310-M (Rear Box)
T310-MLR (Rear Box)

T310ME (Rear box, same as T310M, output flange extended for rear mount PTO)
T318 (Rear Box)

LEFT SIDE ONLY

RIGHT SIDE ONLY

TRANSMISSION GEAR DATA:

L.S. 08-BOLT Opening Gear FORWARD of Centerline
49 Teeth - SPUR

PITCH LINE TO APERTURE FACE:

0.6670" (16.9400MM)

TRANSMISSION GEAR DATA:

R.S. 06-BOLT Opening Gear FORWARD of Centerline
49 Teeth - SPUR

PITCH LINE TO APERTURE FACE:

1.0550" (26.8000MM)

CAUTION: Application Approval Required for PTO Output Shaft Speeds Above 2500 RPM

PTO Model	Torq I / C †	Dir Rot	Engine %		Filler Block	Adapter Assy	Stud Kit	PTO Model	Torq I / C †	Dir Rot	Engine %		Filler Block	Adapter Assy	Stud Kit
			Fwd	Rev							Fwd	Rev			

GEARED ADAPTERS

628ZDAX-5DA	250 I	Eng		8-A-062		328170-190X	626ZDAX-3DA	250 I	Eng		7-A-140		Furnished
							645ZDAX-3DA	250 I	Eng		7-A-140		Furnished

Available PTO Output Shaft Speeds with Rear Box in Neutral

Transmission Shifter & Selection Location			Multiplication Factor	Transmission Shifter & Selection Location			Multiplication Factor
LO	LO	LO	0.2755	5	HI	HI	0.5146
LO	HI	LO	0.3250	6	LO	HI	0.6097
1	LO	LO	0.4363	6	HI	HI	0.7197
1	HI	LO	0.5146	7	LO	HI	0.8482
2	LO	LO	0.6097	7	HI	HI	1.0000
2	HI	LO	0.7197	8	LO	HI	1.1910
3	LO	LO	0.8482	8	HI	HI	1.4040
3	HI	LO	1.0000	REV	HI	HI	0.1547
4	LO	LO	1.1910	REV	LO	HI	0.1305
4	HI	LO	1.4040	REV	LO	LO	0.1547
5	LO	HI	0.4363	REV	HI	LO	0.1305

EXAMPLE: Main Box in 4 HI LO with 442ZQDAX on Rear Box with output speed of 103% x 1.404 = 144.6%

CAUTION: PTO operations not permitted by Mack in "HI" range position (shaded area).

† I = Intermittent Torque Only - De-rate Torque Rating 30% for Continuous Duty.

C = Continuous or Intermittent Torque - No need to De-Rate Torque Rating.

IMPORTANT: Refer to the back of this transmission section and read all notes associated with this application page. Some notes may affect the proper PTO selection.

CAUTION: Do not use geared adapters with 442 A and C ratios.

CAUTION: Mack Does Not approve PTO operations with the Range Selector in the "HI" position. Damage to the transmission synchronizers may occur. Refer to Mack operator's manual for correct PTO operation.

Mack

MAK-28

MACK

CHELSEA®

T2130 (Rear Box)
T2130-B (Rear Box)
T313LR (Rear Box)
T313L (Rear Box)
T313L21 (Rear Box)
T313LR21 (Rear Box)
T313H (Rear Box)

LEFT SIDE ONLY

RIGHT SIDE ONLY

TRANSMISSION GEAR DATA:

L.S. 08-BOLT Opening Gear FORWARD of Centerline
49 Teeth - SPUR

PITCH LINE TO APERTURE FACE:
0.6670" (16.9400MM)

TRANSMISSION GEAR DATA:

R.S. 06-BOLT Opening Gear FORWARD of Centerline
49 Teeth - SPUR

PITCH LINE TO APERTURE FACE:
1.0550" (26.8000MM)

CAUTION: Application Approval Required for PTO Output Shaft Speeds Above 2500 RPM

PTO Model	Torq I / C †	Dir Rot	Engine %		Filler Block	Adapter Assy	Stud Kit	PTO Model	Torq I / C †	Dir Rot	Engine %		Filler Block	Adapter Assy	Stud Kit
			Fwd	Rev							Fwd	Rev			

ONE SPEED - TWO GEAR - MECHANICAL SHIFT

221ZCDAX-5	250 I	Opp	45		7-A-062(P)	328564X	Furnished	221XCDAX-3	250 I	Opp	45		7-A-032		Furnished
221ZEDAX-5	250 I	Opp	50		7-A-062(P)	328564X	Furnished	221XEDAX-3	250 I	Opp	50		7-A-032		Furnished
489ZADAX-5 (8)	250 I	Opp	40		8-A-062		328170-190X	442ZADAX-3 (8)	250 I	Opp	40		7-A-140		Furnished
489ZCDAX-5 (9)	250 I	Opp	51		8-A-062		328170-190X	442ZCDAX-3 (9)	250 I	Opp	51		7-A-140		Furnished
489ZFDAX-5 (2)	250 I	Opp	63		8-A-062		328170-190X	442ZFDAX-3 (2)	250 I	Opp	63		7-A-140		Furnished
489ZHDAX-5 (13)	250 I	Opp	73		8-A-062		328170-190X	442ZHDAX-3 (13)	250 I	Opp	73		7-A-140		Furnished
489ZLDAX-5 (1)	250 I	Opp	81		8-A-062		328170-190X	442ZLDAX-3 (1)	250 I	Opp	81		7-A-140		Furnished
489ZQDAX-5 (1)	225 I	Opp	88		8-A-062		328170-190X	442ZQDAX-3 (1)	225 I	Opp	88		7-A-140		Furnished
489ZRDAX-5 (1)	225 I	Opp	101		8-A-062		328170-190X	442ZRDAX-3 (1)	225 I	Opp	101		7-A-140		Furnished
489ZSDAX-5 (1)	200 I	Opp	121		8-A-062		328170-190X	442ZSDAX-3 (1)	200 I	Opp	121		7-A-140		Furnished
489ZUDAX-5 (1)	195 I	Opp	144		8-A-062		328170-190X	442ZUDAX-3 (1)	195 I	Opp	144		7-A-140		Furnished
489ZWDAX-5 (1)	175 I	Opp	169		8-A-062		328170-190X	442ZWDAX-3 (1)	175 I	Opp	169		7-A-140		Furnished
489ZXDAX-5 (1)	140 I	Opp	200		8-A-062		328170-190X	442ZXDAX-3 (1)	140 I	Opp	200		7-A-140		Furnished
680ZFDAX-5 (10)	375 I	Opp	63		8-A-062		328170-190X	660ZFDAX-3 (10)	375 I	Opp	63		7-A-140		Furnished
680ZQDAX-5 (11)	375 I	Opp	88		8-A-062		328170-190X	660ZQDAX-3 (11)	375 I	Opp	88		7-A-140		Furnished
680ZSDAX-5 (12)	325 I	Opp	121		8-A-062		328170-190X	660ZSDAX-3 (12)	325 I	Opp	121		7-A-140		Furnished
823XBDAX-5 (33)	500 I	Opp	41				Furnished								
823XMDAX-5 (34)	500 I	Opp	73				Furnished								
823XRDAX-5 (35)	400 I	Opp	100				Furnished								
880XBDAX-5 (3)	500 I	Opp	41				Furnished								
880XGDAX-5 (7)	500 I	Opp	53				Furnished								
880XMDAX-5 (4)	500 I	Opp	73				Furnished								
880XRDAX-5 (5)	400 I	Opp	100				Furnished								
880XTDAX-5 (6)	350 I	Opp	129				Furnished								

ONE SPEED - TWO GEAR POWERSHIFT (AIR OR HYDRAULIC)

282KBDAX-5 (15)	300 C	Opp	41		8-A-062		Furnished	272XADAX-3 (24)	300 C	Opp	34		7-A-032		Furnished
282KCDAX-5 (16)	300 C	Opp	50		8-A-062		Furnished	272XBDAX-3 (25)	300 C	Opp	41		7-A-032		Furnished
282KDDAX-5 (17)	300 C	Opp	60		8-A-062		Furnished	272XCDAX-3 (26)	300 C	Opp	50		7-A-032		Furnished
282KGDAX-5 (18)	300 C	Opp	71		8-A-062		Furnished	272XDAJX-3 (14)	300 C	Opp	60		7-A-032		Furnished
282KKDAX-5 (19)	300 C	Opp	80		8-A-062		Furnished	272XGDAX-3 (27)	300 C	Opp	71		7-A-032		Furnished
282KKDAX-5 (19)	300 C	Opp	89		8-A-062		Furnished	272XKDAX-3 (28)	300 C	Opp	80		7-A-032		Furnished

† I = Intermittent Torque Only - De-rate Torque Rating 30% for Continuous Duty.

C = Continuous or Intermittent Torque - No need to De-Rate Torque Rating.

IMPORTANT: Refer to the back of this transmission section and read all notes associated with this application page. Some notes may affect the proper PTO selection.

CAUTION: Do not use geared adapters with 442 A and C ratios.

- (1) Input Gear Part No. 5-P-1037
- (2) Input Gear Part No. 5-P-1085
- (3) Input Gear Part No. 5-P-1120
- (4) Input Gear Part No. 5-P-1121
- (5) Input Gear Part No. 5-P-1122
- (6) Input Gear Part No. 5-P-1123

- (7) Input Gear Part No. 5-P-1174
- (8) Input Gear Part No. 5-P-1284
- (9) Input Gear Part No. 5-P-1291
- (10) Input Gear Part No. 5-P-1330
- (11) Input Gear Part No. 5-P-1331
- (12) Input Gear Part No. 5-P-1332

- (13) Input Gear Part No. 5-P-1365
- (14) Input Gear Part No. 5-P-1510-4X
- (15) Input Gear Part No. 5-P-1511-11X
- (16) Input Gear Part No. 5-P-1511-12X
- (17) Input Gear Part No. 5-P-1511-13X
- (18) Input Gear Part No. 5-P-1511-14X

- (19) Input Gear Part No. 5-P-1511-15X
- (20) Input Gear Part No. 5-P-1511-16X
- (24) Input Gear Part No. 5-P-1511-1X
- (25) Input Gear Part No. 5-P-1511-2X
- (26) Input Gear Part No. 5-P-1511-3X
- (27) Input Gear Part No. 5-P-1511-5X

- (28) Input Gear Part No. 5-P-1511-6X
- (33) Input Gear Part No. 5-P-636
- (34) Input Gear Part No. 5-P-637
- (35) Input Gear Part No. 5-P-808

CHELSEA®

MACK

MAK-28

T2130 (Rear Box)
T2130-B (Rear Box)
T313LR (Rear Box)
T313L (Rear Box)
T313L21 (Rear Box)
T313LR21 (Rear Box)
T313H (Rear Box)

LEFT SIDE ONLY

RIGHT SIDE ONLY

TRANSMISSION GEAR DATA:

L.S. 08-BOLT Opening Gear FORWARD of Centerline
49 Teeth - SPUR

PITCH LINE TO APERTURE FACE:

0.6670" (16.9400MM)

TRANSMISSION GEAR DATA:

R.S. 06-BOLT Opening Gear FORWARD of Centerline
49 Teeth - SPUR

PITCH LINE TO APERTURE FACE:

1.0550" (26.8000MM)

CAUTION: Application Approval Required for PTO Output Shaft Speeds Above 2500 RPM

PTO Model	Torq I / C †	Dir Rot	Engine %		Filler Block	Adapter Assy	Stud Kit	PTO Model	Torq I / C †	Dir Rot	Engine %		Filler Block	Adapter Assy	Stud Kit
			Fwd	Rev							Fwd	Rev			
ONE SPEED - TWO GEAR POWERSHIFT (AIR OR HYDRAULIC)															
282KPDAX-*5 (21)	300 C	Opp	100		8-A-062		Furnished	272XMDAX-*3 (29)	300 C	Opp	89		7-A-032		Furnished
282KSDAX-*5 (22)	300 C	Opp	111		8-A-062		Furnished	272XPDX-*3 (30)	300 C	Opp	100		7-A-032		Furnished
282KTDAX-*5 (23)	300 C	Opp	125		8-A-062		Furnished	272XSDAX-*3 (31)	300 C	Opp	111		7-A-032		Furnished
ONE SPEED - POWERSHIFT LOW PROFILE (AIR OR HYDRAULIC)															
								272MADAX-*3 (24)	300 C	Opp	34		7-A-032		Furnished
								272MBDAX-*3 (25)	300 C	Opp	41		7-A-032		Furnished
								272MCDAX-*3 (26)	300 C	Opp	50		7-A-032		Furnished
								272MDAJX-*3 (14)	300 C	Opp	60		7-A-032		Furnished
								272MGDAX-*3 (27)	300 C	Opp	71		7-A-032		Furnished
								272MKDAX-*3 (28)	300 C	Opp	80		7-A-032		Furnished
								272MMDAX-*3 (29)	300 C	Opp	89		7-A-032		Furnished
								272MPDAX-*3 (30)	300 C	Opp	100		7-A-032		Furnished
								272MSDAX-*3 (31)	300 C	Opp	111		7-A-032		Furnished
ONE SPEED - TWO GEAR - POWERSHIFT (AIR)															
885XBDAX-*5 (3)	500 I	Opp	41				Furnished								
885XGDAX-*5 (7)	500 I	Opp	53				Furnished								
885XMDAX-*5 (4)	500 I	Opp	73				Furnished								
ONE SPEED - FORWARD & REVERSE															
348ZFDAX-*5 (32)	200 I	Opp	57	60	8-A-032		328170-190X	340SFDAX-*5 (32)	200 I	Opp	57	60	7-A-062		Furnished
863XBDAX-*5	500 I	Opp	41	51			Furnished								
GEARED ADAPTERS															
628ZDAX-5DA	250 I	Eng			8-A-062		328170-190X	626ZDAX-3DA	250 I	Eng			7-A-140		Furnished
								645ZDAX-3DA	250 I	Eng			7-A-140		Furnished

† I = Intermittent Torque Only - De-rate Torque Rating 30% for Continuous Duty.

C = Continuous or Intermittent Torque - No need to De-Rate Torque Rating.

IMPORTANT: Refer to the back of this transmission section and read all notes associated with this application page.
Some notes may affect the proper PTO selection.

CAUTION: Do not use geared adapters with 442 A and C ratios.

(3) Input Gear Part No. 5-P-1120
(4) Input Gear Part No. 5-P-1121
(7) Input Gear Part No. 5-P-1174
(14) Input Gear Part No. 5-P-1510-4X
(21) Input Gear Part No. 5-P-1511-17X
(22) Input Gear Part No. 5-P-1511-18X

(23) Input Gear Part No. 5-P-1511-19X
(24) Input Gear Part No. 5-P-1511-1X
(25) Input Gear Part No. 5-p-1511-2X
(26) Input Gear Part No. 5-P-1511-3X
(27) Input Gear Part No. 5-P-1511-5X
(28) Input Gear Part No. 5-P-1511-6X

(29) Input Gear Part No. 5-P-1511-7X
(30) Input Gear Part No. 5-P-1511-8X
(31) Input Gear Part No. 5-P-1511-9X
(32) Input Gear Part No. 5-P-634

MAK-29

MACK

CHELSEA®

T2050-C
T2060-C
T2070-D (Front Box)
T2070-C
T2080-D (Front Box)
T2080-C

LEFT SIDE ONLY

RIGHT SIDE ONLY

TRANSMISSION GEAR DATA:

L.S. 08-BOLT Opening Gear FORWARD of Centerline
48 Teeth - SPUR

PITCH LINE TO APERTURE FACE:
0.9770" (24.8200MM)

TRANSMISSION GEAR DATA:

L.S. 06-BOLT Opening Gear FORWARD of Centerline
48 Teeth - SPUR

PITCH LINE TO APERTURE FACE:
1.2520" (31.8000MM)

CAUTION: Application Approval Required for PTO Output Shaft Speeds Above 2500 RPM

PTO Model	Torq I / C †	Dir Rot	Engine %		Filler Block	Adapter Assy	Stud Kit	PTO Model	Torq I / C †	Dir Rot	Engine %		Filler Block	Adapter Assy	Stud Kit
			Fwd	Rev							Fwd	Rev			

ONE SPEED - TWO GEAR - MECHANICAL SHIFT

823ZBAHX-*3 (28)	500 I	Opp	71		8-A-700		328170-133X	221ZCAHX-*3	250 I	Opp	75		7-A-062 7-A032(33)		Furnished
823ZDAHx-*3 (31)	500 I	Opp	84		8-A-700		328170-133X	221ZEAHX-*3	250 I	Opp	86		7-A-032		Furnished
823ZGAHX-*3 (32)	500 I	Opp	91		8-A-700		328170-133X	442ZAAHX-*3 (12)	250 I	Opp	66		7-A-032		Furnished
823ZJAHX-*3 (29)	500 I	Opp	107		8-A-700		328170-133X	442ZCAHX-*3 (13)	250 I	Opp	84		7-A-032		Furnished
823ZMAHX-*3 (27)	500 I	Opp	126		8-A-700		328170-133X	442ZFAHX-*3 (2)	250 I	Opp	104		7-A-032		Furnished
823ZRAHX-*3 (30)	400 I	Opp	173		8-A-700		328170-133X	442ZHAHX-*3 (15)	250 I	Opp	121		7-A-032		Furnished
880ZBAHX-*3 (3)	500 I	Opp	71		8-A-700		328170-133X	442ZLAHX-*3 (1)	250 I	Opp	134		7-A-032		Furnished
880ZDAHx-*3 (4)	500 I	Opp	84		8-A-700		328170-133X	442ZQAHX-*3 (1)	225 I	Opp	145		7-A-032		Furnished
880ZGAHX-*3 (9)	500 I	Opp	91		8-A-700		328170-133X	442ZRAHX-*3 (1)	225 I	Opp	167		7-A-032		Furnished
880ZJAHX-*3 (5)	500 I	Opp	107		8-A-700		328170-133X	442ZSAHX-*3 (1)	200 I	Opp	199		7-A-032		Furnished
880ZMAHX-*3 (6)	500 I	Opp	126		8-A-700		328170-133X	442ZUAHX-*3 (1)	195 I	Opp	237		7-A-032		Furnished
880ZQAHX-*3 (16)	450 I	Opp	147		8-A-700		328170-133X	442ZWAHX-*3 (1)	175 I	Opp	279		7-A-032		Furnished
880ZRAHX-*3 (7)	400 I	Opp	173		8-A-700		328170-133X	442ZXAHX-*3 (1)	140 I	Opp	330		7-A-032		Furnished
880ZTAHX-*3 (8)	350 I	Opp	223		8-A-700		328170-133X	660ZFAHX-*3 (10)	375 I	Opp	104		7-A-032		Furnished
								660ZHAXH-*3 (15)	375 I	Opp	121		7-A-032		Furnished
								660ZQAHX-*3 (11)	375 I	Opp	145		7-A-032		Furnished
								660ZRAHX-*3 (17)	350 I	Opp	167		7-A-032		Furnished
								660ZSAHX-*3 (14)	325 I	Opp	199		7-A-032		Furnished

ONE SPEED - TWO GEAR POWERSHIFT (AIR OR HYDRAULIC)

272ZAAJX-*5 (18)	300 C	Opp	53		7-A-032	328481X	Furnished	272ZAAJX-*3 (18)	300 C	Opp	53		7-A-032		Furnished
272ZBAJX-*5 (19)	300 C	Opp	65		7-A-032	328481X	Furnished	272ZBAJX-*3 (19)	300 C	Opp	65		7-A-032		Furnished
272ZCAJX-*5 (20)	300 C	Opp	79		7-A-032	328481X	Furnished	272ZCAJX-*3 (20)	300 C	Opp	79		7-A-032		Furnished
272ZDAJX-*5 (21)	300 C	Opp	95		7-A-032	328481X	Furnished	272ZDAJX-*3 (21)	300 C	Opp	95		7-A-032		Furnished
272ZGAJX-*5 (22)	300 C	Opp	113		7-A-032	328481X	Furnished	272ZGAJX-*3 (22)	300 C	Opp	113		7-A-032		Furnished
272ZKAJX-*5 (23)	300 C	Opp	126		7-A-032	328481X	Furnished	272ZKAJX-*3 (23)	300 C	Opp	126		7-A-032		Furnished
272ZMAJX-*5 (24)	300 C	Opp	141		7-A-032	328481X	Furnished	272ZMAJX-*3 (24)	300 C	Opp	141		7-A-032		Furnished
272ZPAJX-*5 (25)	300 C	Opp	157		7-A-032	328481X	Furnished	272ZPAJX-*3 (25)	300 C	Opp	157		7-A-032		Furnished
272ZSAJX-*5 (26)	284 C	Opp	176		7-A-032	328481X	Furnished	272ZSAJX-*3 (26)	284 C	Opp	176		7-A-032		Furnished

† I = Intermittent Torque Only - De-rate Torque Rating 30% for Continuous Duty.

C = Continuous or Intermittent Torque - No need to De-Rate Torque Rating.

IMPORTANT: Refer to the back of this transmission section and read all notes associated with this application page. Some notes may affect the proper PTO selection.

Mack

- (1) Input Gear Part No. 5-P-1004
- (2) Input Gear Part No. 5-P-1077
- (3) Input Gear Part No. 5-P-1100
- (4) Input Gear Part No. 5-P-1101
- (5) Input Gear Part No. 5-P-1102
- (6) Input Gear Part No. 5-P-1103
- (7) Input Gear Part No. 5-P-1104

- (8) Input Gear Part No. 5-P-1105
- (9) Input Gear Part No. 5-P-1135
- (10) Input Gear Part No. 5-P-1242
- (11) Input Gear Part No. 5-P-1246
- (12) Input Gear Part No. 5-P-1280
- (13) Input Gear Part No. 5-P-1287
- (14) Input Gear Part No. 5-P-1322

- (15) Input Gear Part No. 5-P-1364
- (16) Input Gear Part No. 5-P-1385
- (17) Input Gear Part No. 5-P-1441
- (18) Input Gear Part No. 5-P-1510-1X
- (19) Input Gear Part No. 5-P-1510-2X
- (20) Input Gear Part No. 5-P-1510-3X
- (21) Input Gear Part No. 5-P-1510-4X

- (22) Input Gear Part No. 5-P-1510-5X
- (23) Input Gear Part No. 5-P-1510-6X
- (24) Input Gear Part No. 5-P-1510-7X
- (25) Input Gear Part No. 5-P-1510-8X
- (26) Input Gear Part No. 5-P-1510-9X
- (27) Input Gear Part No. 5-P-283
- (28) Input Gear Part No. 5-P-285

- (29) Input Gear Part No. 5-P-325
- (30) Input Gear Part No. 5-P-721
- (31) Input Gear Part No. 5-P-971
- (32) Input Gear Part No. 5-P-980
- (33) Furnished, but not required

CHELSEA®

MACK

MAK-29

T2050-C
T2060-C
T2070-D (Front Box)
T2070-C
T2080-D (Front Box)
T2080-C

LEFT SIDE ONLY

RIGHT SIDE ONLY

TRANSMISSION GEAR DATA:

L.S. 08-BOLT Opening Gear FORWARD of Centerline
48 Teeth - SPUR

PITCH LINE TO APERTURE FACE:

0.9770" (24.8200MM)

TRANSMISSION GEAR DATA:

R.S. 06-BOLT Opening Gear FORWARD of Centerline
48 Teeth - SPUR

PITCH LINE TO APERTURE FACE:

1.2520" (31.8000MM)

CAUTION: Application Approval Required for PTO Output Shaft Speeds Above 2500 RPM

PTO Model	Torq	Dir Rot	Engine %		Filler Block	Adapter Assy	Stud Kit	PTO Model	Torq	Dir Rot	Engine %		Filler Block	Adapter Assy	Stud Kit
	I / C †		Fwd	Rev					I / C †		Fwd	Rev			

ONE SPEED - TWO GEAR - POWERSHIFT (AIR)

885ZBAHX-*3 (3)	500 I	Opp	71		8-A-700		328170-133X								
885ZGAHX-*3 (9)	500 I	Opp	91		8-A-700		328170-133X								
885ZJAHX-*3 (5)	500 I	Opp	107		8-A-700		328170-133X								
885ZMAHX-*3 (6)	500 I	Opp	126		8-A-700		328170-133X								

GEARED ADAPTERS

626ZDAX-3DA	250 I	Eng			7-A-032	Furnished
630ZDAX-3DA	250 I	Eng			7-A-032	Furnished
645ZDAX-3DA	250 I	Eng			7-A-032	Furnished

† I = Intermittent Torque Only - De-rate Torque Rating 30% for Continuous Duty.

C = Continuous or Intermittent Torque - No need to De-Rate Torque Rating.

IMPORTANT: Refer to the back of this transmission section and read all notes associated with this application page.
Some notes may affect the proper PTO selection.

(3) Input Gear Part No. 5-P-1100
(9) Input Gear Part No. 5-P-1102
(5) Input Gear Part No. 5-P-1103
(6) Input Gear Part No. 5-P-1135

MAK-30

MACK

CHELSEA®

T2060-A
T306G

LEFT SIDE ONLY

RIGHT SIDE ONLY

TRANSMISSION GEAR DATA:

L.S. 08-BOLT Opening Gear FORWARD of Centerline
40 Teeth - SPUR

PITCH LINE TO APERTURE FACE:
1.9280" (48.9700MM)

TRANSMISSION GEAR DATA:

RS. 06-BOLT Opening Gear FORWARD of Centerline
40 Teeth - SPUR

PITCH LINE TO APERTURE FACE:
2.2040" (55.9800MM)

CAUTION: Application Approval Required for PTO Output Shaft Speeds Above 2500 RPM

PTO Model	Torq	Dir Rot	Engine %		Filler Block	Adapter Assy	Stud Kit	PTO Model	Torq	Dir Rot	Engine %		Filler Block	Adapter Assy	Stud Kit
	I / C †		Fwd	Rev					I / C †		Fwd	Rev			

ONE SPEED - TWO GEAR - MECHANICAL SHIFT

290KFHUX-*5 (1)	180 I	Opp	80		7-A-093(5)	328564X	7170-3X	290KFHUX-*3 (1)	180 I	Opp	80		7-A-270		7170-4X
290KLHUX-*5 (2)	180 I	Opp	94		7-A-093	328564X	7170-3X	290KLHUX-*3 (2)	180 I	Opp	94		7-A-270		7170-4X
290KQHUX-*5 (3)	180 I	Opp	124		7-A-093	328564X	7170-3X	290KQHUX-*3 (3)	180 I	Opp	124		7-A-270		7170-4X
290KUHUX-*5 (4)	180 I	Opp	149		7-A-093	328564X	7170-3X	290KUHUX-*3 (4)	180 I	Opp	149		7-A-270		7170-4X

† I = Intermittent Torque Only - De-rate Torque Rating 30% for Continuous Duty.

C = Continuous or Intermittent Torque - No need to De-Rate Torque Rating.

IMPORTANT: Refer to the back of this transmission section and read all notes associated with this application page. Some notes may affect the proper PTO selection.

(1) Input Gear Part No. 5-P-1221
(2) Input Gear Part No. 5-P-1222
(3) Input Gear Part No. 5-P-1223
(4) Input Gear Part No. 5-P-1224
(5) Filler block furnished with PTO

T2110-B (REAR BOX FOR T2110B)

LEFT SIDE ONLY

RIGHT SIDE ONLY

TRANSMISSION GEAR DATA:

L.S. 08-BOLT Opening Gear FORWARD of Centerline
49 Teeth - SPUR

PITCH LINE TO APERTURE FACE:

0.6670" (16.9400MM)

TRANSMISSION GEAR DATA:

R.S. 06-BOLT Opening Gear FORWARD of Centerline
49 Teeth - SPUR

PITCH LINE TO APERTURE FACE:

1.0550" (26.7970MM)

CAUTION: Application Approval Required for PTO Output Shaft Speeds Above 2500 RPM

PTO Model	Torq I / C †	Dir Rot	Engine %		Filler Block	Adapter Assy	Stud Kit	PTO Model	Torq I / C †	Dir Rot	Engine %		Filler Block	Adapter Assy	Stud Kit
			Fwd	Rev							Fwd	Rev			

ONE SPEED - TWO GEAR - MECHANICAL SHIFT

221ZCDAX-*5 (32)	250 I	Opp	54		7-A-062(P)	328564X	Furnished	221XCDAX-*3 (32)	250 I	Opp	54		7-A-032		Furnished
221ZEDAX-*5 (32)	250 I	Opp	59		7-A-062(P)	328564X	Furnished	221XEDAX-*3 (32)	250 I	Opp	59		7-A-032		Furnished
489ZFDAX-*5 (2)	250 I	Opp	74		8-A-062		328170-190X	442ZADAX-*3 (8)	250 I	Opp	47		7-A-140		Furnished
489ZHDAX-*5 (13)	250 I	Opp	86		8-A-062		328170-190X	442ZCDAX-*3 (9)	250 I	Opp	60		7-A-140		Furnished
489ZLDAX-*5 (1)	250 I	Opp	96		8-A-062		328170-190X	442ZFDAX-*3 (2)	250 I	Opp	74		7-A-140		Furnished
489ZQDAX-*5 (1)	225 I	Opp	103		8-A-062		328170-190X	442ZHDAX-*3 (13)	250 I	Opp	86		7-A-140		Furnished
489ZRDAX-*5 (1)	225 I	Opp	120		8-A-062		328170-190X	442ZLDAX-*3 (1)	250 I	Opp	96		7-A-140		Furnished
489ZSDAX-*5 (1)	200 I	Opp	142		8-A-062		328170-190X	442ZQDAX-*3 (1)	225 I	Opp	103		7-A-140		Furnished
489ZUDAX-*5 (1)	195 I	Opp	169		8-A-062		328170-190X	442ZRDAX-*3 (1)	225 I	Opp	120		7-A-140		Furnished
489ZWDAX-*5 (1)	175 I	Opp	199		8-A-062		328170-190X	442ZSDAX-*3 (1)	200 I	Opp	142		7-A-140		Furnished
489ZXDAX-*5 (1)	140 I	Opp	236		8-A-062		328170-190X	442ZUDAX-*3 (1)	195 I	Opp	169		7-A-140		Furnished
680ZFDAX-*5 (10)	375 I	Opp	74		8-A-062		328170-190X	442ZWDAX-*3 (1)	175 I	Opp	199		7-A-140		Furnished
680ZQDAX-*5 (11)	375 I	Opp	103		8-A-062		328170-190X	442ZXDAX-*3 (1)	140 I	Opp	236		7-A-140		Furnished
680ZSDAX-*5 (12)	325 I	Opp	142		8-A-062		328170-190X	660ZFDAX-*3 (10)	375 I	Opp	74		7-A-140		Furnished
823XBDAX-*5	500 I	Opp	48				Furnished	660ZQDAX-*3 (11)	375 I	Opp	103				Furnished
823XMDAX-*5 (34)	500 I	Opp	86				Furnished	660ZSDAX-*3 (12)	325 I	Opp	142				Furnished
823XRDAX-*5 (35)	400 I	Opp	118				Furnished								
880XBDAX-*5 (3)	500 I	Opp	48				Furnished								
880XGDAX-*5 (7)	500 I	Opp	62				Furnished								
880XMDAX-*5 (4)	500 I	Opp	86				Furnished								
880XRDAX-*5 (5)	400 I	Opp	118				Furnished								
880XTDAX-*5 (6)	350 I	Opp	152				Furnished								

ONE SPEED - TWO GEAR POWERSHIFT (AIR OR HYDRAULIC)

282XBDAX-*5 (14)	300 C	Opp	49		8-A-062(P)		Furnished	272XADAX-*3 (23)	300 C	Opp	40		7-A-032		Furnished
282XCDAX-*5 (15)	300 C	Opp	59		8-A-062(P)		Furnished	272XBDAX-*3 (24)	300 C	Opp	49		7-A-032		Furnished
282XDDAX-*5 (16)	300 C	Opp	71		8-A-062(P)		Furnished	272XCDAX-*3 (25)	300 C	Opp	59		7-A-032		Furnished
282XGDAX-*5 (17)	300 C	Opp	84		8-A-062(P)		Furnished	272XDDAX-*3 (26)	300 C	Opp	71		7-A-032		Furnished
282XKDAX-*5 (18)	300 C	Opp	94		8-A-062(P)		Furnished	272XGDAX-*3 (27)	300 C	Opp	84		7-A-032		Furnished
282XMDAX-*5 (19)	300 C	Opp	105		8-A-062		Furnished	272XKDAX-*3 (28)	300 C	Opp	94		7-A-032		Furnished
282XPDAX-*5 (20)	300 C	Opp	117		8-A-062(P)		Furnished	272XMDAX-*3 (29)	300 C	Opp	105		7-A-032		Furnished

† I = Intermittent Torque Only - De-rate Torque Rating 30% for Continuous Duty.

C = Continuous or Intermittent Torque - No need to De-Rate Torque Rating.

IMPORTANT: Refer to the back of this transmission section and read all notes associated with this application page. Some notes may affect the proper PTO selection.

- (1) Input Gear Part No. 5-P-1037
- (2) Input Gear Part No. 5-P-1085
- (3) Input Gear Part No. 5-P-1120
- (4) Input Gear Part No. 5-P-1121
- (5) Input Gear Part No. 5-P-1122
- (6) Input Gear Part No. 5-P-1123
- (7) Input Gear Part No. 5-P-1174

- (8) Input Gear Part No. 5-P-1284
- (9) Input Gear Part No. 5-P-1291
- (10) Input Gear Part No. 5-P-1330
- (11) Input Gear Part No. 5-P-1331
- (12) Input Gear Part No. 5-P-1332
- (13) Input Gear Part No. 5-P-1365
- (14) Input Gear Part No. 5-P-1511-11X

- (15) Input Gear Part No. 5-P-1511-12X
- (16) Input Gear Part No. 5-P-1511-13X
- (17) Input Gear Part No. 5-P-1511-14X
- (18) Input Gear Part No. 5-P-1511-15X
- (19) Input Gear Part No. 5-P-1511-16X
- (20) Input Gear Part No. 5-P-1511-17X
- (23) Input Gear Part No. 5-P-1511-1X

- (24) Input Gear Part No. 5-p-1511-2X
- (25) Input Gear Part No. 5-P-1511-3X
- (26) Input Gear Part No. 5-P-1511-4X
- (27) Input Gear Part No. 5-P-1511-5X
- (28) Input Gear Part No. 5-P-1511-6X
- (29) Input Gear Part No. 5-P-1511-7X
- (32) Input Gear Part No. 5-P-633

- (34) Input Gear Part No. 5-P-637
- (35) Input Gear Part No. 5-P-808

MAK-31

MACK

CHELSEA®

T2110-B (REAR BOX FOR T2110B)

LEFT SIDE ONLY

RIGHT SIDE ONLY

TRANSMISSION GEAR DATA:

L.S. 08-BOLT Opening Gear FORWARD of Centerline
49 Teeth - SPUR

PITCH LINE TO APERTURE FACE:
0.6670" (16.9400MM)

TRANSMISSION GEAR DATA:

R.S. 06-BOLT Opening Gear FORWARD of Centerline
49 Teeth - SPUR

PITCH LINE TO APERTURE FACE:
1.0550" (26.7970MM)

CAUTION: Application Approval Required for PTO Output Shaft Speeds Above 2500 RPM

PTO Model	Torq I / C †	Dir Rot	Engine %		Filler Block	Adapter Assy	Stud Kit	PTO Model	Torq I / C †	Dir Rot	Engine %		Filler Block	Adapter Assy	Stud Kit
			Fwd	Rev							Fwd	Rev			

ONE SPEED - TWO GEAR POWERSHIFT (AIR OR HYDRAULIC)

282XSDAX-*5 (21)	300 C	Opp	131		8-A-062(P)		Furnished	272XPDAX-*3 (30)	300 C	Opp	117		7-A-032		Furnished
282XTDAX-*5 (22)	300 C	Opp	147		8-A-062(P)		Furnished	272XSDAX-*3 (31)	300 C	Opp	131		7-A-032		Furnished

ONE SPEED - POWERSHIFT LOW PROFILE (AIR OR HYDRAULIC)

272MADAX-*3 (23)	300 C	Opp	40					7-A-032					Furnished
272MBDAX-*3 (24)	300 C	Opp	49					7-A-032					Furnished
272MCDAX-*3 (25)	300 C	Opp	59					7-A-032					Furnished
272MDDAX-*3 (26)	300 C	Opp	71					7-A-032					Furnished
272MGDAX-*3 (27)	300 C	Opp	84					7-A-032					Furnished
272MKDAX-*3 (28)	300 C	Opp	94					7-A-032					Furnished
272MMDAX-*3 (29)	300 C	Opp	105					7-A-032					Furnished
272MPDAX-*3 (30)	300 C	Opp	117					7-A-032					Furnished
272MSDAX-*3 (31)	300 C	Opp	131					7-A-032					Furnished

ONE SPEED - TWO GEAR - POWERSHIFT (AIR)

885XBDAX-*5 (3)	500 I	Opp	48				Furnished							
885XGDAX-*5 (7)	500 I	Opp	62				Furnished							
885XMDAX-*5 (4)	500 I	Opp	86				Furnished							

ONE SPEED - FORWARD & REVERSE

348ZFDAX-*5 (33)	200 I	Eng	68	71	8-A-062	328170-190X	340SFDAX-*3 (33)	200 I	Opp	68	71	7-A-062		Furnished
863XBDAX-*5	500 I	Opp	48	60			Furnished							

GEARED ADAPTERS

628ZDAX-5DA	250 I	Eng			8-A-062	328170-190X	626ZDAX-3DA	250 I	Eng			7-A-140		Furnished
							630ZDAX-3DA	250 I	Eng			7-A-140		Furnished
							645ZDAX-3DA	250 I	Eng			7-A-140		Furnished

† I = Intermittent Torque Only - De-rate Torque Rating 30% for Continuous Duty.

C = Continuous or Intermittent Torque - No need to De-Rate Torque Rating.

IMPORTANT: Refer to the back of this transmission section and read all notes associated with this application page. Some notes may affect the proper PTO selection.

Mack

- | | | |
|---------------------------------------|--------------------------------------|--------------------------------------|
| (3) Input Gear Part No. 5-P-1120 | (24) Input Gear Part No. 5-p-1511-2X | (30) Input Gear Part No. 5-P-1511-8X |
| (4) Input Gear Part No. 5-P-1121 | (25) Input Gear Part No. 5-p-1511-3X | (31) Input Gear Part No. 5-P-1511-9X |
| (7) Input Gear Part No. 5-P-1174 | (26) Input Gear Part No. 5-p-1511-4X | (33) Input Gear Part No. 5-P-634 |
| (21) Input Gear Part No. 5-P-1511-18X | (27) Input Gear Part No. 5-P-1511-5X | |
| (22) Input Gear Part No. 5-P-1511-19X | (28) Input Gear Part No. 5-P-1511-6X | |
| (23) Input Gear Part No. 5-P-1511-1X | (29) Input Gear Part No. 5-P-1511-7X | |

T310 (T310 is a standard 10 speed with no rear box)
T310-M (Front Box)
T310ME (Front box, same as T-310M, output flange extended for rear mount PTO)

LEFT SIDE ONLY

RIGHT SIDE ONLY

TRANSMISSION GEAR DATA:
L.S. 08-BOLT Opening Gear FORWARD of Centerline
53 Teeth - SPUR
PITCH LINE TO APERTURE FACE:
0.8100" (20.5700MM)

TRANSMISSION GEAR DATA:
R.S. 06-BOLT Opening Gear FORWARD of Centerline
53 Teeth - SPUR
PITCH LINE TO APERTURE FACE:
1.0800" (27.4320MM)

CAUTION: Application Approval Required for PTO Output Shaft Speeds Above 2500 RPM

PTO Model	Torq I / C †	Dir Rot	Engine %		Filler Block	Adapter Assy	Stud Kit	PTO Model	Torq I / C †	Dir Rot	Engine %		Filler Block	Adapter Assy	Stud Kit
			Fwd	Rev							Fwd	Rev			

ONE SPEED - TWO GEAR - MECHANICAL SHIFT

221ZCDAX-*5	250 I	Opp	66			328564X	Furnished	221XCAHX-*3	250 I	Eng	65		7-A-032(P)(35)	328554-2X	Furnished
221ZEDAX-*5	250 I	Opp	73			328564X	Furnished	221XCDAX-*3	250 I	Opp	66				Furnished
489ZADAX-*5 (8)	250 I	Opp	57				Furnished	221XEAHX-*3	250 I	Eng	75			328554-2X	Furnished
489ZCDAX-*5 (9)	250 I	Opp	74				Furnished	221XEDAX-*3	250 I	Opp	73				Furnished
489ZFDAX-*5 (2)	250 I	Opp	92				Furnished	442ZADAX-*3 (8)	250 I	Opp	57		7-A-093		Furnished
489ZHDAX-*5 (13)	250 I	Opp	107				Furnished	442ZCDAX-*3 (9)	250 I	Opp	74		7-A-093		Furnished
489ZLDAX-*5 (1)	250 I	Opp	119				Furnished	442ZFDAX-*3 (2)	250 I	Opp	92		7-A-093		Furnished
489ZQDAX-*5 (1)	225 I	Opp	128				Furnished	442ZHDAX-*3 (13)	250 I	Opp	107		7-A-093		Furnished
489ZRDAX-*5 (1)	225 I	Opp	149				Furnished	442ZLDAX-*3 (1)	250 I	Opp	119		7-A-093		Furnished
489ZSDAX-*5 (1)	200 I	Opp	178				Furnished	442ZQDAX-*3 (1)	225 I	Opp	128		7-A-093		Furnished
489ZUDAX-*5 (1)	195 I	Opp	212				Furnished	442ZRDAX-*3 (1)	225 I	Opp	149		7-A-093		Furnished
489ZWDAX-*5 (1)	175 I	Opp	250				Furnished	442ZSDAX-*3 (1)	200 I	Opp	178		7-A-093		Furnished
489ZXDAX-*5 (1)	140 I	Opp	296				Furnished	442ZUDAX-*3 (1)	195 I	Opp	212		7-A-093		Furnished
680ZFDAX-*5 (10)	375 I	Opp	92				Furnished	442ZWDAX-*3 (1)	175 I	Opp	250		7-A-093		Furnished
680ZQDAX-*5 (11)	375 I	Opp	128				Furnished	442ZXDAX-*3 (1)	140 I	Opp	296		7-A-093		Furnished
680ZSDAX-*5 (12)	325 I	Opp	178				Furnished	660ZFDAX-*3 (10)	375 I	Opp	92		7-A-062		Furnished
823XBDAX-*5	500 I	Opp	59				Furnished	660ZQDAX-*3 (11)	375 I	Opp	128		7-A-062		Furnished
823XMDAX-*5 (33)	500 I	Opp	106				Furnished	660ZSDAX-*3 (12)	325 I	Opp	178		7-A-062		Furnished
823XRDAX-*5 (34)	400 I	Opp	148				Furnished								
880XBDAX-*5 (3)	500 I	Opp	59				Furnished								
880XGDAX-*5 (7)	500 I	Opp	76				Furnished								
880XMDAX-*5 (4)	500 I	Opp	106				Furnished								
880XRDAX-*5 (5)	400 I	Opp	148				Furnished								
880XTDAX-*5 (6)	350 I	Opp	191				Furnished								

ONE SPEED - TWO GEAR POWERSHIFT (AIR OR HYDRAULIC)

282XBDAX-*5 (14)	300 C	Opp	61				Furnished	272XADAX-*3 (23)	300 C	Opp	49				Furnished
282XCDAX-*5 (15)	300 C	Opp	73				Furnished	272XBDAX-*3 (24)	300 C	Opp	61				Furnished
282XDDAX-*5 (16)	300 C	Opp	88				Furnished	272XCDAX-*3 (25)	300 C	Opp	73				Furnished
282XGDAX-*5 (17)	300 C	Opp	104				Furnished	272XDDAX-*3 (26)	300 C	Opp	88				Furnished
282XKDAX-*5 (18)	300 C	Opp	117				Furnished	272XGDAX-*3 (27)	300 C	Opp	104				Furnished
282XMDAX-*5 (19)	300 C	Opp	130				Furnished	272XKDAX-*3 (28)	300 C	Opp	117				Furnished

† I = Intermittent Torque Only - De-rate Torque Rating 30% for Continuous Duty.

C = Continuous or Intermittent Torque - No need to De-Rate Torque Rating.

IMPORTANT: Refer to the back of this transmission section and read all notes associated with this application page. Some notes may affect the proper PTO selection.

CAUTION: Do not use geared adapters with 442 A and C ratios.

- (1) Input Gear Part No. 5-P-1037
- (2) Input Gear Part No. 5-P-1085
- (3) Input Gear Part No. 5-P-1120
- (4) Input Gear Part No. 5-P-1121
- (5) Input Gear Part No. 5-P-1122
- (6) Input Gear Part No. 5-P-1123

- (7) Input Gear Part No. 5-P-1174
- (8) Input Gear Part No. 5-P-1284
- (9) Input Gear Part No. 5-P-1291
- (10) Input Gear Part No. 5-P-1330
- (11) Input Gear Part No. 5-P-1331
- (12) Input Gear Part No. 5-P-1332

- (13) Input Gear Part No. 5-P-1365
- (14) Input Gear Part No. 5-P-1511-11X
- (15) Input Gear Part No. 5-P-1511-12X
- (16) Input Gear Part No. 5-P-1511-13X
- (17) Input Gear Part No. 5-P-1511-14X
- (18) Input Gear Part No. 5-P-1511-15X

- (19) Input Gear Part No. 5-P-1511-16X
- (23) Input Gear Part No. 5-P-1511-1X
- (24) Input Gear Part No. 5-p-1511-2X
- (25) Input Gear Part No. 5-P-1511-3X
- (26) Input Gear Part No. 5-P-1511-4X
- (27) Input Gear Part No. 5-P-1511-5X

- (28) Input Gear Part No. 5-P-1511-6X
- (33) Input Gear Part No. 5-P-637
- (34) Input Gear Part No. 5-P-808
- (35) Filler block furnished with PTO

MAK-32

MACK

CHELSEA®

T310 (T310 is a standard 10 speed with no rear box)
T310-M (Front Box)
T310ME (Front box, same as T-310M, output flange extended for rear mount PTO)

LEFT SIDE ONLY

RIGHT SIDE ONLY

TRANSMISSION GEAR DATA:

L.S. 08-BOLT Opening Gear FORWARD of Centerline
53 Teeth - SPUR

PITCH LINE TO APERTURE FACE:
0.8100" (20.5700MM)

TRANSMISSION GEAR DATA:

R.S. 06-BOLT Opening Gear FORWARD of Centerline
53 Teeth - SPUR

PITCH LINE TO APERTURE FACE:
1.0800" (27.4320MM)

CAUTION: Application Approval Required for PTO Output Shaft Speeds Above 2500 RPM

PTO Model	Torq I / C †	Dir Rot	Engine %		Filler Block	Adapter Assy	Stud Kit	PTO Model	Torq I / C †	Dir Rot	Engine %		Filler Block	Adapter Assy	Stud Kit
			Fwd	Rev							Fwd	Rev			

ONE SPEED - TWO GEAR POWERSHIFT (AIR OR HYDRAULIC)

282XPDAX-*5 (20)	300 C	Opp	146			Furnished	272XMDAX-*3 (29)	300 C	Opp	130					Furnished
282XSDAX-*5 (21)	300 C	Opp	163			Furnished	272XPDAX-*3 (30)	300 C	Opp	146					Furnished
282XTDAX-*5 (22)	274 C	Opp	182			Furnished	272XSDAX-*3 (31)	300 C	Opp	163					Furnished

ONE SPEED - POWERSHIFT LOW PROFILE (AIR OR HYDRAULIC)

272MADAX-*3 (23)	300 C	Opp	49			Furnished
272MBDAX-*3 (24)	300 C	Opp	61			Furnished
272MCDAX-*3 (25)	300 C	Opp	73			Furnished
272MDAX-*3 (26)	300 C	Opp	88			Furnished
272MGDAX-*3 (27)	300 C	Opp	104			Furnished
272MKDAX-*3 (28)	300 C	Opp	117			Furnished
272MMDAX-*3 (29)	300 C	Opp	130			Furnished
272MPDAX-*3 (30)	300 C	Opp	146			Furnished
272MSDAX-*3 (31)	300 C	Opp	163			Furnished

ONE SPEED - TWO GEAR - POWERSHIFT (AIR)

885XBDAX-*5 (3)	500 I	Opp	59			Furnished
885XGDAX-*5 (7)	500 I	Opp	76			Furnished
885XMDAX-*5 (4)	500 I	Opp	106			Furnished

ONE SPEED - FORWARD & REVERSE

348ZFDAX-*5 (32)	200 I	Opp	83	90		Furnished	340SFDAX-*5 (32)	200 I	Opp	83	90			Furnished
863XBDAX-*5	500 I	Opp	59	75		Furnished								

GEARED ADAPTERS

628ZDAX-5DA	250 I	Eng				Furnished	626ZDAX-3DA	250 I	Eng			7-A-062		Furnished
							630ZDAX-3DA	250 I	Eng			7-A-062		Furnished
							645ZDAX-3DA	250 I	Eng			7-A-062		Furnished

† I = Intermittent Torque Only - De-rate Torque Rating 30% for Continuous Duty.

C = Continuous or Intermittent Torque - No need to De-Rate Torque Rating.

IMPORTANT: Refer to the back of this transmission section and read all notes associated with this application page. Some notes may affect the proper PTO selection.

CAUTION: Do not use geared adapters with 442 A and C ratios.

(3) Input Gear Part No. 5-P-1120
(4) Input Gear Part No. 5-P-1121
(7) Input Gear Part No. 5-P-1174
(20) Input Gear Part No. 5-P-1511-17X
(21) Input Gear Part No. 5-P-1511-18X
(22) Input Gear Part No. 5-P-1511-19X

(23) Input Gear Part No. 5-P-1511-1X
(24) Input Gear Part No. 5-p-1511-2X
(25) Input Gear Part No. 5-P-1511-3X
(26) Input Gear Part No. 5-P-1511-4X
(27) Input Gear Part No. 5-P-1511-5X
(28) Input Gear Part No. 5-P-1511-6X

(29) Input Gear Part No. 5-P-1511-7X
(30) Input Gear Part No. 5-P-1511-8X
(31) Input Gear Part No. 5-P-1511-9X
(32) Input Gear Part No. 5-P-634

CHELSEA®

MACK

MAK-33

TM308
TM309

LEFT SIDE ONLY

RIGHT SIDE ONLY

TRANSMISSION GEAR DATA:

L.S. 08-BOLT Opening Gear FORWARD of Centerline
54 Teeth - SPUR

PITCH LINE TO APERTURE FACE:

0.8100" (20.5700MM)

TRANSMISSION GEAR DATA:

R.S. 06-BOLT Opening Gear FORWARD of Centerline
54 Teeth - SPUR

PITCH LINE TO APERTURE FACE:

1.0850" (27.5600MM)

CAUTION: Application Approval Required for PTO Output Shaft Speeds Above 2500 RPM

PTO Model	Torq I / C †	Dir Rot	Engine %		Filler Block	Adapter Assy	Stud Kit	PTO Model	Torq I / C †	Dir Rot	Engine %		Filler Block	Adapter Assy	Stud Kit
			Fwd	Rev							Fwd	Rev			

ONE SPEED - TWO GEAR - MECHANICAL SHIFT

442ZFDAX-*6 (2)	250 I	Opp	94		7-A-062(P)	328481X	Furnished	442ZFDAX-*4 (2)	250 I	Opp	94		7-A-062		Furnished
442ZHDAX-*6 (10)	250 I	Opp	109		7-A-062(P)	328481X	Furnished	442ZHDAX-*4 (10)	250 I	Opp	109		7-A-062		Furnished
442ZLDAX-*6 (1)	250 I	Opp	121		7-A-062(P)	328481X	Furnished	442ZLDAX-*4 (1)	250 I	Opp	121		7-A-062		Furnished
442ZQDAX-*6 (1)	225 I	Opp	130		7-A-062(P)	328481X	Furnished	442ZQDAX-*4 (1)	225 I	Opp	130		7-A-062		Furnished
489ZFDAX-*6 (2)	250 I	Opp	94				Furnished	660ZFDAX-*4 (8)	375 I	Opp	94		7-A-062		Furnished
489ZHDAX-*6 (10)	250 I	Opp	109				Furnished	660ZQDAX-*4 (9)	375 I	Opp	130		7-A-062		Furnished
489ZLDAX-*6 (1)	250 I	Opp	121				Furnished								
489ZQDAX-*6 (1)	225 I	Opp	130				Furnished								
680ZFDAX-*6 (8)	375 I	Opp	94				Furnished								
680ZQDAX-*6 (9)	375 I	Opp	130				Furnished								
880XBDAX-*6 (3)	500 I	Opp	61				Furnished								
880XGDAX-*6 (7)	500 I	Opp	78				Furnished								
880XMDAX-*6 (4)	500 I	Opp	108				Furnished								
880XRDAX-*6 (5)	400 I	Opp	150				Furnished								
880XTDAX-*6 (6)	350 I	Opp	193				Furnished								

ONE SPEED - TWO GEAR - POWERSHIFT (AIR)

885XBDAX-*6 (3)	500 I	Opp	61				Furnished								
885XGDAX-*6 (7)	500 I	Opp	78				Furnished								
885XMDAX-*6 (4)	500 I	Opp	108				Furnished								

ONE SPEED - FORWARD & REVERSE

348ZFDAX-*4 (11)	200 I	Opp	85	90			Furnished	340SFDAX-*4 (11)	200 I	Opp	85	90			Furnished
863XBDAX-*4 (12)	500 I	Opp	61	75			Furnished								

GEARED ADAPTERS

628ZDAX-6DA	250 I	Eng					Furnished	626ZDAX-4DA	250 I	Eng			7-A-062		Furnished
								630ZDAX-4DA	250 I	Eng			7-A-062		Furnished
								645ZDAX-4DA	250 I	Eng			7-A-062		Furnished

† I = Intermittent Torque Only - De-rate Torque Rating 30% for Continuous Duty.

C = Continuous or Intermittent Torque - No need to De-Rate Torque Rating.

IMPORTANT: Refer to the back of this transmission section and read all notes associated with this application page. Some notes may affect the proper PTO selection.

CAUTION: Do not use geared adapters with 442 A and C ratios.

CAUTION: Do not install any PTO models with a sliding input gear, the input gear will not shift completely out of mesh.

(1) Input Gear Part No. 5-P-1037
 (2) Input Gear Part No. 5-P-1085
 (3) Input Gear Part No. 5-P-1120
 (4) Input Gear Part No. 5-P-1121
 (5) Input Gear Part No. 5-P-1122
 (6) Input Gear Part No. 5-P-1123

(7) Input Gear Part No. 5-P-1174
 (8) Input Gear Part No. 5-P-1330
 (9) Input Gear Part No. 5-P-1331
 (10) Input Gear Part No. 5-P-1365
 (11) Input Gear Part No. 5-P-634
 (12) Input Gear Part No. 5-P-636

MAK-34

MACK

CHELSEA®

TMD12AD (MDrive) Low Ratio
TMD12AFD (MDrive) Low Ratio
TMD12AFD-HD (MDrive) Low Ratio
TMD13AD (MDrive) Low Ratio
TMD13AFD-HD (MDrive) Low Ratio

REAR SIDE ONLY

TRANSMISSION GEAR DATA:

REAR 04-BOLT Opening

PITCH LINE TO APERTURE FACE:

CAUTION: Application Approval Required for PTO Output Shaft Speeds Above 2500 RPM

PTO Model	Torq	Dir Rot	Engine %		Filler Block	Adapter Assy	Stud Kit	PTO Model	Torq	Dir Rot	Engine %		Filler Block	Adapter Assy	Stud Kit
	I / C †		Fwd	Rev					I / C †		Fwd	Rev			

REAR MOUNT - MECHANICAL SHIFT (12 SPEED TRANSMISSIONS)

512XRASW-V-XY	258 C	Opp	70				Furnished
512XRASX-V-XK	258 C	Opp	70				Furnished
512XRASX-V-XV	258 C	Opp	70				Furnished
524XTASX-V-*	300 C	Eng	93				Furnished
524XVASX-V-*	258 C	Eng	126				Furnished

† I = Intermittent Torque Only - De-rate Torque Rating 30% for Continuous Duty.

C = Continuous or Intermittent Torque - No need to De-Rate Torque Rating.

IMPORTANT: Refer to the back of this transmission section and read all notes associated with this application page. Some notes may affect the proper PTO selection.

Mack

CHELSEA®

MACK

MAK-34H

TMD12AD (MDrive) High Split Ratio
TMD12AFD (MDrive) High Split Ratio
TMD12AFD-HD (MDrive) High Split Ratio
TMD13AD (MDrive) High Split Ratio
TMD13AFD-HD (MDrive) High Split Ratio

REAR SIDE ONLY

TRANSMISSION GEAR DATA:

REAR 04-BOLT Opening

PITCH LINE TO APERTURE FACE:

CAUTION: Application Approval Required for PTO Output Shaft Speeds Above 2500 RPM

PTO Model	Torq	Dir Rot	Engine %		Filler Block	Adapter Assy	Stud Kit	PTO Model	Torq	Dir Rot	Engine %		Filler Block	Adapter Assy	Stud Kit
	I / C †		Fwd	Rev					I / C †		Fwd	Rev			

REAR MOUNT - MECHANICAL SHIFT (12 SPEED TRANSMISSIONS)

512XRASW-V-XY	258 C	Opp	90				Furnished
512XRASX-V-XK	258 C	Opp	90				Furnished
512XRASX-V-XV	258 C	Opp	90				Furnished
524XTASX-V-*	300 C	Eng	119				Furnished
524XVASX-V-*	258 C	Eng	161				Furnished

† I = Intermittent Torque Only - De-rate Torque Rating 30% for Continuous Duty.

C = Continuous or Intermittent Torque - No need to De-Rate Torque Rating.

IMPORTANT: Refer to the back of this transmission section and read all notes associated with this application page. Some notes may affect the proper PTO selection.

Mack

MAK-35

MACK

CHELSEA®

TMD12AFO (MDrive) Low Ratio
 TMD12AFO-HD (MDrive) Low Ratio
 TMD12AO (MDrive) Low Ratio
 TMD13AFO-HD (MDrive) Low Ratio
 TMD13AO (MDrive) Low Ratio
 TMD14AFO-HD (MDrive) Low Ratio
 TMD14AO (MDrive) Low Ratio

REAR SIDE ONLY

TRANSMISSION GEAR DATA:

REAR 04-BOLT Opening

PITCH LINE TO APERTURE FACE:

CAUTION: Application Approval Required for PTO Output Shaft Speeds Above 2500 RPM

PTO Model	Torq	Dir Rot	Engine %		Filler Block	Adapter Assy	Stud Kit	PTO Model	Torq	Dir Rot	Engine %		Filler Block	Adapter Assy	Stud Kit
	I / C †		Fwd	Rev					I / C †		Fwd	Rev			

REAR MOUNT - MECHANICAL SHIFT (12 SPEED TRANSMISSIONS)

512XRASW-V-XY	258 C	Opp	90				Furnished
512XRASX-V-XK	258 C	Opp	90				Furnished
512XRASX-V-XV	258 C	Opp	90				Furnished
524XTASX-V-*	300 C	Eng	120				Furnished
524XVASX-V-*	258 C	Eng	162				Furnished

† I = Intermittent Torque Only - De-rate Torque Rating 30% for Continuous Duty.

C = Continuous or Intermittent Torque - No need to De-Rate Torque Rating.

IMPORTANT: Refer to the back of this transmission section and read all notes associated with this application page. Some notes may affect the proper PTO selection.

Mack

CHELSEA®

MACK

MAK-35H

TMD12AFO (MDrive) High Split Ratio
TMD12AFO-HD (MDrive) High Split Ratio
TMD12AO (MDrive) High Split Range
TMD13AFO-HD (MDrive) High Split Range
TMD13AO (MDrive) High Split Range
TMD14AFO-HD (MDrive) High Split Range
TMD14AO (MDrive) High Split Range

REAR SIDE ONLY

TRANSMISSION GEAR DATA:

REAR 04-BOLT Opening

PITCH LINE TO APERTURE FACE:

CAUTION: Application Approval Required for PTO Output Shaft Speeds Above 2500 RPM

PTO Model	Torq	Dir Rot	Engine %		Filler Block	Adapter Assy	Stud Kit	PTO Model	Torq	Dir Rot	Engine %		Filler Block	Adapter Assy	Stud Kit
	I / C †		Fwd	Rev					I / C †		Fwd	Rev			

REAR MOUNT - MECHANICAL SHIFT (12 SPEED TRANSMISSIONS)

512XRASW-V-XY	258 C	Opp	115				Furnished
512XRASX-V-XK	258 C	Opp	115				Furnished
512XRASX-V-XV	258 C	Opp	115				Furnished
524XTASX-V-*	300 C	Eng	154				Furnished
524XVASX-V-*	258 C	Eng	207				Furnished

† I = Intermittent Torque Only - De-rate Torque Rating 30% for Continuous Duty.

C = Continuous or Intermittent Torque - No need to De-Rate Torque Rating.

IMPORTANT: Refer to the back of this transmission section and read all notes associated with this application page. Some notes may affect the proper PTO selection.

Mack

Mack Notes

MAK-16

1. With gear selector lever in low range for the front portion of compound transmissions, multiply speeds shown by the factor listed for the transmission: TRDXL-107, DX-107 multiply by .595; TRDXL-1071, DX-1071 multiply by .350. This feature can cause insufficient PTO speed, particularly in spreading applications.
2. With gear selector lever in high range for the front portion of compound transmissions, multiply speed shown by the factor listed for the transmission: TRDXL-1070, DX-1070, TRDXL-10780, DX-10780 multiply by 1.62. This feature can cause excessive PTO speeds.
3. The AK & XK output flanges can not be used with the A & C ratios on the 489 Series PTOs due to mounting stud interference. Use a RA or RB rotatable flange for the XK and the RA for the AK flange.
4. 272/282 Series - Must be used as an AIR Shift PTO. Order Air Shift Options Only

MAK-18

1. All speeds shown are with transmission in 5th speed. For PTO speeds with the main transmission in all other gears, multiply speeds shown by the following: for 1st - .116, 2nd - .200, 3rd - .353, 4th - .603.
2. The AK & XK output flanges can not be used with the A & C ratios on the 489 Series PTOs due to mounting stud interference. Use a RA or RB rotatable flange for the XK and the RA for the AK flange.
3. 272/282 Series - Must be used as an AIR Shift PTO. Order Air Shift Options Only

MAK-19

1. All speeds shown are with transmission in 5th speed. For PTO speeds with the main transmission in all other gears, multiply speeds shown by the following: for 1st - .116, 2nd - .200, 3rd - .353, 4th - .603.
2. The AK & XK output flanges can not be used with the A & C ratios on the 489 Series PTOs due to mounting stud interference. Use a RA or RB rotatable flange for the XK and the RA for the AK flange.
3. The 812 Series PTO will not mount on this transmission because the output shaft interferes with the reverse idler buldge.
4. 272/282 Series - Must be used as an AIR Shift PTO. Order Air Shift Options Only

MAK-20

1. The AK & XK output flanges can not be used with the A & C ratios on the 489 Series PTOs due to mounting stud interference. Use a RA or RB rotatable flange for the XK and the RA for the AK flange.
2. 272/282 Series - Must be used as an AIR Shift PTO. Order Air Shift Options Only

MAK-21

1. All speeds figured with transmission in 4th speed direct. For PTO speeds in other transmission gears, multiply speeds shown by following: 1st. = .1907, 2nd. = .3282, 3rd. = .5780, 5th. = 1.6744.
2. 489 Series - The AK & XK output flanges can not be used with the A & C ratios due to mounting stud interference. Use a RA or RB rotatable flange for the XK and the RA for the AK flange.
3. 272/282 Series - Must be used as an AIR Shift PTO. Order Air Shift Options Only

MAK-22

1. The AK & XK output flanges can not be used with the A & C ratios on the 489 Series PTOs due to mounting stud interference. Use a RA or RB rotatable flange for the XK and the RA for the AK flange.
2. 272/282 Series - Must be used as an AIR Shift PTO. Order Air Shift Options Only

MAK-23

1. Using the 328554-2X adapter will permit PTO installation on trucks with set back front axle.
2. The AK & XK output flanges can not be used with the A & C ratios on the 489 Series PTOs due to mounting stud interference. Use a RA or RB rotatable flange for the XK and the RA for the AK flange.
3. 272/282 Series - Must be used as an AIR Shift PTO. Order Air Shift Options Only

MAK-24

- 1 Using the 328554-2X adapter will permit PTO installation on trucks with set back front axle.
2. The AK & XK output flanges can not be used with the A & C ratios on the 489 Series PTOs due to mounting stud interference. Use a RA or RB rotatable flange for the XK and the RA for the AK flange.
3. 272/282 Series - Must be used as an AIR Shift PTO. Order Air Shift Options Only

Mack Notes

MAK-25

1. Using the 328554-2X adapter will permit PTO installation on trucks with set back front axle.
 2. All the applications shown are for the front box.
 3. The AK & XK output flanges can not be used with the A & C ratios on the 489 Series PTOs due to mounting stud interference. Use a RA or RB rotatable flange for the XK and the RA for the AK flange.
 4. 272/282 Series - Must be used as an AIR Shift PTO. Order Air Shift Options Only
-

MAK-26

1. On the R.H. side the 328554-2X adapter can be used with an AH PTO to change rotation.
 2. All speeds shown are with the main transmission in 5th speed. For PTO speeds with the main transmission in all other gears, divide the speeds shown by the following percentages: 1st. = 8.76, 2nd. = 5.995, 3rd. = 2.895, 4th. = 1.674, Reverse = 8.99
 3. The AK & XK output flanges can not be used with the A & C ratios on the 489 Series PTOs due to mounting stud interference. Use a RA or RB rotatable flange for the XK and the RA for the AK flange.
 4. 272/282 Series - Must be used as an AIR Shift PTO. Order Air Shift Options Only
-

MAK-27

1. This application is for the rear box only. For front box applications, see application no. MAK-23.
 2. With main box in reverse, the direction of rotation on the PTO output shaft will change.
 3. The AK & XK output flanges can not be used with the A & C ratios on the 489 Series PTOs due to mounting stud interference. Use a RA or RB rotatable flange for the XK and the RA for the AK flange.
 4. All speeds shown are with the transmission in 7th speed, or direct, and rear box in neutral. For speeds with main box in all the gear positions available, see the PTO speed chart on last MAK-27 page.
 5. 272/282 Series - Must be used as an AIR Shift PTO. Order Air Shift Options Only
-

MAK-28

1. All speeds shown are with the main transmission in 4th., 10th., or 11th speed, and rear box in neutral. For speeds with main transmission in other gears, multiply speeds shown as follows: 1st. = .323; 2nd., 6th. & 7th. = .515; 3rd., 8th., & 9th. = .720; 5th., 12th., & 13th = 1.405.
 2. With main box in reverse the direction of rotation on the PTO output shaft will change.
 3. The AK & XK output flanges can not be used with the A & C ratios on the 489 Series PTOs due to mounting stud interference. Use a RA or RB rotatable flange for the XK and the RA for the AK flange.
 4. 272/282 Series - Must be used as an AIR Shift PTO. Order Air Shift Options Only
-

MAK-29

1. 272/282 Series - Must be used as an AIR Shift PTO. Order Air Shift Options Only
-

MAK-30

1. The XK flange cannot be used with the L and U ratio because of interference with the transmission.
-

MAK-31

1. For PTO output speeds on the T2110B Main Section, see Mack application MAK-24.
 2. The Rear Section PTO speeds are shown with the Main Section in 5th gear or Direct and the Rear Section in Neutral.
 3. For all other Main Section gear shift positions use the following multiplication factors to determine your PTO output speeds: 1st gear = .255, 2nd & 7th gear = .450, 3rd & 8th gear = .590, 4th & 9th gear = .629 and 6th & 11th gear = 1.067.
 4. 272/282 Series - Must be used as an AIR Shift PTO. Order Air Shift Options Only
-

MAK-32

1. Using the 328554-2X adapter will permit PTO installation on trucks with set back front axle.
2. The AK & XK output flanges can not be used with the A & C ratios on the 489 Series PTOs due to mounting stud interference. Use a RA or RB rotatable flange for the XK and the RA for the AK flange.
3. 272/282 Series - Must be used as an AIR Shift PTO. Order Air Shift Options Only

Mack Notes

MAK-33

1. The 54 tooth gear in the transmission is located rearward of the vertical center line by .320.
 2. The 442/489 R, S, U, W, X ratios and 880 R and T ratios cannot be mounted on this transmission because the OD of the ratio gear will interfere with the OD of the 54 tooth PTO drive gear in the transmission.
 3. 272/282 Series - Must be used as an AIR Shift PTO. Order Air Shift Options Only
-

MAK-34

1. Connection to Volvo/Mack system required for Volvo I-Shift or Mack M-Drive, the vehicle needs to be ordered with PTO prep package. Vehicle ECU must be programmed by dealer for PTO operation.
 2. PTO must be ordered with the V shift option and use the OE factory supplied in-dash PTO switch.
 3. 511/523 Rear Mount - The Adapter 329735X is furnished with the PTO.
 4. 524 Rear Mount - The adapter 329980X is furnished with the PTO
-

MAK-34H

1. Connection to Volvo/Mack system required for Volvo I-Shift or Mack M-Drive, the vehicle needs to be ordered with PTO prep package.
2. PTO must be ordered with the V shift option and use the OE factory supplied in-dash PTO switch.
3. 511/523 Rear Mount - The Adapter 329735X is furnished with the PTO.
4. 524 Rear Mount - The adapter 329980X is furnished with the PTO

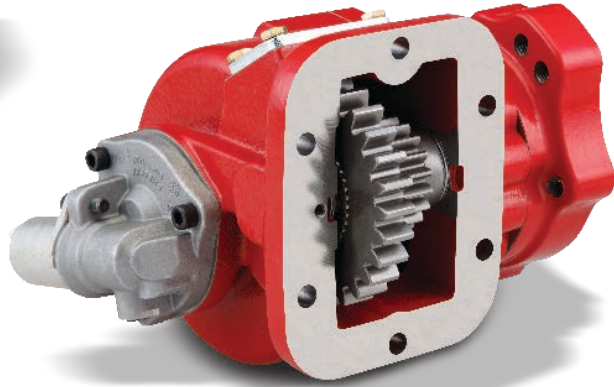
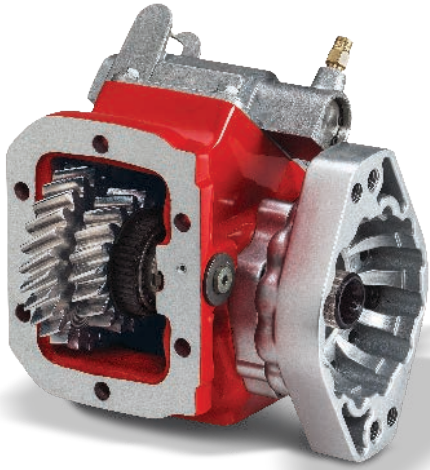

MERCEDES/DAIMLER/DETROIT

Parker | Chelsea

ENGINEERING YOUR SUCCESS.

**WARNING — User Responsibility**

FAILURE OR IMPROPER SELECTION OR IMPROPER USE OF THE PRODUCTS DESCRIBED HEREIN OR RELATED ITEMS CAN CAUSE DEATH, PERSONAL INJURY AND PROPERTY DAMAGE.

This document and other information from Parker Hannifin Corporation, its subsidiaries and authorized distributors provide product or system options for further investigation by users having technical expertise.

The user, through its own analysis and testing, is solely responsible for making the final selection of the system and components and assuring that all performance, endurance, maintenance, safety and warning requirements of the application are met. The user must analyze all aspects of the application, follow applicable industry standards, and follow the information concerning the product in the current product catalog and in any other materials provided from Parker or its subsidiaries or authorized distributors.

To the extent that Parker or its subsidiaries or authorized distributors provide component or system options based upon data or specifications provided by the user, the user is responsible for determining that such data and specifications are suitable and sufficient for all applications and reasonably foreseeable uses of the components or systems.

Offer of Sale

The items described in this document are hereby offered for sale by Parker Hannifin Corporation, its subsidiaries or its authorized distributors. This offer and its acceptance are governed by the provisions stated in the "Offer of Sale".



WARNING: This product can expose you to chemicals including Lead and Lead Compounds, and Di(2-ethylhexyl)phthalate (DEHP) which are known to the State of California to cause cancer and birth defects or other reproductive harm. For more information go to www.P65Warnings.ca.gov

© Copyright 2022, Parker Hannifin Corporation, All Rights Reserved

MERCEDES/DAIMLER/DETROIT TRANSMISSION INDEX

Transmission Make and Model	PTO Appl. Number	Number Forward Speeds	Teeth in PTO Driver
AMT3-660-60A (Automated Manual)	M/B-6	6	R53
ATM3-520-6DA (Automated Manual)	M/B-5	6	R45
DT12-DH (DT12-DA, G 281-12)	M/B-11A	12	CS
DT12-DHE (DT12-DC, G 271-12)	M/B-13	12	CS-B30
DT12-DHL (DT12-DB, G 211-12)	M/B-11B	12	CS
DT12-DV (DT12-DC, G 271-12)	M/B-13	12	CS-B30
DT12-OH (DT12-OA, G 330-12)	M/B-10A	12	CS
DT12-OHE (DT12-OC, G 320-12)	M/B-12	12	CS-B39
DT12-OHL (DT12-OB, G 230-12)	M/B-10B	12	CS
DT12-OV (DT12-OC, G 320-12)	M/B-12	12	CS-B39
DT12-OVX (DT12-OD, G 340-12)	M/B-14	12	CS-B40
G33	M/B-7	5	R43
G56 (See DDG-2 for Dodge/Sterling/RAM Trucks)	M/B-8	6	L52
G85	M/B-6	6	R53
MBT520-6DA (AGS - Automated Gear Shift)	M/B-5	6	R45
MBT520S-6D	M/B-5	6	R45
MBT660-60A (AGS - Automated Gear Shift)	M/B-6	6	R53
MBT660S-60	M/B-6	6	R53



IMPORTANT: See Safety Information in Section 1 of the Chelsea Applications catalog HY25-3000/US

Transmission PTO Driver & Apertures (Viewed from Rear of Transmission)
L-Left Side R-Right Side B-Bottom Side T-Top Side CS-Countershaft
For transmissions not listed, contact your authorized Chelsea Distributor.

M/B-5

MERCEDES/DAIMLER/DETROIT



ATM3-520-6DA (Automated Manual)
MBT520-6DA (AGS - Automated Gear Shift)
MBT520S-6D

RIGHT SIDE ONLY

TRANSMISSION GEAR DATA:
R.S. 06-BOLT Opening Gear REAR of Centerline
45 Teeth - R.H. HELIX
PITCH LINE TO APERTURE FACE:
1.4240" (36.1696MM)

CAUTION: Application Approval Required for PTO Output Shaft Speeds Above 2500 RPM

PTO Model	Torq	Dir Rot	Engine %		Filler Block	Adapter Assy	Stud Kit	PTO Model	Torq	Dir Rot	Engine %		Filler Block	Adapter Assy	Stud Kit
	I / C †		Fwd	Rev					I / C †		Fwd	Rev			

ONE SPEED - TWO GEAR - MECHANICAL SHIFT

442ZLJGX-*4 (1)	250 I	Opp	54	7170-72X
442LQJGX-*4 (1)	225 I	Opp	58	7170-72X
442LRJGX-*4 (1)	225 I	Opp	67	7170-72X
442LSJGX-*4 (1)	200 I	Opp	79	7170-72X
442ZUJGX-*4 (1)	195 I	Opp	95	7170-72X
442ZWJGX-*4 (1)	175 I	Opp	111	7170-72X
442ZXJGX-*4 (1)	140 I	Opp	132	7170-72X

Mercedes/Daimler/Detroit

† I = Intermittent Torque Only - De-rate Torque Rating 30% for Continuous Duty. C = Continuous or Intermittent Torque - No need to De-Rate Torque Rating.

IMPORTANT: Refer to the back of this transmission section and read all notes associated with this application page. Some notes may affect the proper PTO selection.

(1) Input Gear Part No. 5-P-1256

CHELSEA®

MERCEDES/DAIMLER/DETROIT

M/B-6

AMT3-660-60A (Automated Manual)
G85
MBT660-60A (AGS - Automated Gear Shift)
MBT660S-60

RIGHT SIDE ONLY

TRANSMISSION GEAR DATA:
R.S. 06-BOLT Opening Gear REAR of Centerline
53 Teeth - R.H. HELIX
PITCH LINE TO APERTURE FACE:
1.3380" (33.9852MM)

CAUTION: Application Approval Required for PTO Output Shaft Speeds Above 2500 RPM

PTO Model	Torq	Dir Rot	Engine %		Filler Block	Adapter Assy	Stud Kit	PTO Model	Torq	Dir Rot	Engine %		Filler Block	Adapter Assy	Stud Kit
	I / C †		Fwd	Rev					I / C †		Fwd	Rev			

ONE SPEED - TWO GEAR - MECHANICAL SHIFT

442GLJHX-*4 (1)	250 I	Opp	84	Furnished
442GQJHX-*4 (1)	225 I	Opp	90	Furnished
442GRJHX-*4 (1)	225 I	Opp	104	Furnished
442GSJHX-*4 (1)	200 I	Opp	124	Furnished
442GUJHX-*4 (1)	195 I	Opp	148	Furnished
442GWJHX-*4 (1)	175 I	Opp	174	Furnished
442GXJHX-*4 (1)	140 I	Opp	206	Furnished

† I = Intermittent Torque Only - De-rate Torque Rating 30% for Continuous Duty.

C = Continuous or Intermittent Torque - No need to De-Rate Torque Rating.

IMPORTANT: Refer to the back of this transmission section and read all notes associated with this application page. Some notes may affect the proper PTO selection.

(1) Input Gear Part No. 5-P-1257

M/B-7

MERCEDES/DAIMLER/DETROIT

CHELSEA®

G33

RIGHT SIDE ONLY

TRANSMISSION GEAR DATA:
R.S. 06-BOLT Opening Gear FORWARD of Centerline
43 Teeth - R.H. HELIX
PITCH LINE TO APERTURE FACE:
0.9589" (24.3600MM)

CAUTION: Application Approval Required for PTO Output Shaft Speeds Above 2500 RPM

PTO Model	Torq	Dir Rot	Engine %		Filler Block	Adapter Assy	Stud Kit	PTO Model	Torq	Dir Rot	Engine %		Filler Block	Adapter Assy	Stud Kit
	I / C †		Fwd	Rev					I / C †		Fwd	Rev			

ONE SPEED - TWO GEAR - MECHANICAL SHIFT

442KLKXC- [†] 3 (1)	250 I	Opp	56		7-A-165(T)	7170-79X
442KQKXC- [†] 3 (1)	225 I	Opp	60		7-A-165(T)	7170-79X
442KRKXC- [†] 3 (1)	225 I	Opp	69		7-A-165(T)	7170-79X
442KSKXC- [†] 3 (1)	200 I	Opp	83		7-A-165(T)	7170-79X
442KUKXC- [†] 3 (1)	195 I	Opp	98		7-A-165(T)	7170-79X
442KWKXC- [†] 3 (1)	175 I	Opp	116		7-A-165(T)	7170-79X
442KXKXC- [†] 3 (1)	140 I	Opp	137		7-A-165(T)	7170-79X

† I = Intermittent Torque Only - De-rate Torque Rating 30% for Continuous Duty. C = Continuous or Intermittent Torque - No need to De-Rate Torque Rating.

IMPORTANT: Refer to the back of this transmission section and read all notes associated with this application page. Some notes may affect the proper PTO selection.

(1) Input Gear Part No. 5-P-1341

Mercedes/Daimler/Detroit

G56 (See DDG-2 for Dodge/Sterling/RAM Trucks)

LEFT SIDE ONLY

TRANSMISSION GEAR DATA:

L.S. 06-BOLT Opening Gear REAR of Centerline
52 Teeth - R.H. HELIX

PITCH LINE TO APERTURE FACE:

1.3760" (35.0000MM)

CAUTION: Application Approval Required for PTO Output Shaft Speeds Above 2500 RPM

PTO Model	Torq	Dir Rot	Engine %		Filler Block	Adapter Assy	Stud Kit	PTO Model	Torq	Dir Rot	Engine %		Filler Block	Adapter Assy	Stud Kit
	I / C †		Fwd	Rev					I / C †		Fwd	Rev			

ONE SPEED - TWO GEAR - MECHANICAL SHIFT

442LLKH-X*6 (1)	250 I	Opp	67				7170-72X
442LQKH-X*6 (1)	225 I	Opp	72				7170-72X
442LRKH-X*6 (1)	225 I	Opp	84				7170-72X
442LSKH-X*6 (1)	200 I	Opp	100				7170-72X
442LUKH-X*6 (1)	195 I	Opp	119				7170-72X
442LWKH-X*6 (1)	175 I	Opp	140				7170-72X
442LXKH-X*6 (1)	140 I	Opp	165				7170-72X

† I = Intermittent Torque Only - De-rate Torque Rating 30% for Continuous Duty.

C = Continuous or Intermittent Torque - No need to De-Rate Torque Rating.

IMPORTANT: Refer to the back of this transmission section and read all notes associated with this application page. Some notes may affect the proper PTO selection.

(1) Input Gear Part No. 5-P-1343

M/B-10A

MERCEDES/DAIMLER/DETROIT



DT12-OH (DT12-OA, G 330-12)

REAR SIDE ONLY

TRANSMISSION GEAR DATA:
REAR 04-BOLT Opening

PITCH LINE TO APERTURE FACE:
0" (0MM)

CAUTION: Application Approval Required for PTO Output Shaft Speeds Above 2500 RPM

PTO Model	Torq	Dir Rot	Engine %		Filler Block	Adapter Assy	Stud Kit	PTO Model	Torq	Dir Rot	Engine %		Filler Block	Adapter Assy	Stud Kit
	I / C †		Fwd	Rev					I / C †		Fwd	Rev			

REAR MOUNT - MECHANICAL SHIFT

524XMDAX-**-**	300	Eng	103	Furnished	Furnished
524XTDAX-**-**	300	Eng	135	Furnished	Furnished
524XUDAX-**-**	300	Eng	149	Furnished	Furnished

Mercedes/Daimler/Detroit

† I = Intermittent Torque Only - De-rate Torque Rating 30% for Continuous Duty. C = Continuous or Intermittent Torque - No need to De-Rate Torque Rating.

IMPORTANT: Refer to the back of this transmission section and read all notes associated with this application page. Some notes may affect the proper PTO selection.

CAUTION: The default data code for the DT12 PTO is "split low" upon PTO activation. Speeds are shown in Low Split. For High Split multiply speed shown by 1.289.

CAUTION: Included shims for 330025X input adapter kit are required for installation.

CAUTION: Maximum allowable yoke swing diameter is 180 mm. There is suitable clearance between the 524 Series PTO and the Meritor RPL35 flange however the RPL25 yoke prohibits mounting a 524 PTO. 524 Series PTOs for this application ship with a sculpted housing.

CAUTION: The maximum allowable bending moment for direct mounted pumps is 354 lb-inch (29.5 lb-ft) [40 Nm] w/o bracket. Refer to DT12 PTO Installation Guide DDC-ENG-MAN-0001.

DT12-OHL (DT12-OB, G 230-12)

REAR SIDE ONLY

TRANSMISSION GEAR DATA:
REAR 04-BOLT Opening

PITCH LINE TO APERTURE FACE:
0" (0MM)

CAUTION: Application Approval Required for PTO Output Shaft Speeds Above 2500 RPM

PTO Model	Torq	Dir Rot	Engine %		Filler Block	Adapter Assy	Stud Kit	PTO Model	Torq	Dir Rot	Engine %		Filler Block	Adapter Assy	Stud Kit
	I / C †		Fwd	Rev					I / C †		Fwd	Rev			

REAR MOUNT - MECHANICAL SHIFT

524XMDBX-**-**	300	Eng	103	Furnished	Furnished
524XTDBX-**-**	300	Eng	135	Furnished	Furnished
524XUDBX-**-**	300	Eng	148	Furnished	Furnished

† I = Intermittent Torque Only - De-rate Torque Rating 30% for Continuous Duty.

C = Continuous or Intermittent Torque - No need to De-Rate Torque Rating.

IMPORTANT: Refer to the back of this transmission section and read all notes associated with this application page. Some notes may affect the proper PTO selection.

CAUTION: The default data code for the DT12 PTO is "split low" upon PTO activation. Speeds are shown in Low Split. For High Split multiply speed shown by 1.289.

CAUTION: Included shims for 330003X input adapter kit are required for installation.

CAUTION: Maximum allowable yoke swing diameter is 180 mm. There is suitable clearance between the 524 Series PTO and the Meritor RPL35 flange however the RPL25 yoke prohibits mounting a 524 PTO. 524 Series PTOs for this application ship with a sculpted housing.

CAUTION: The maximum allowable bending moment for direct mounted pumps is 354 lb-inch (29.5 lb-ft) [40 Nm] w/o bracket. Refer to DT12 PTO Installation Guide DDC-ENG-MAN-0001.

M/B-11A

MERCEDES/DAIMLER/DETROIT

CHELSEA®

DT12-DH (DT12-DA, G 281-12)

REAR SIDE ONLY

TRANSMISSION GEAR DATA:
REAR 04-BOLT Opening

PITCH LINE TO APERTURE FACE:
0" (0MM)

CAUTION: Application Approval Required for PTO Output Shaft Speeds Above 2500 RPM

PTO Model	Torq	Dir Rot	Engine %		Filler Block	Adapter Assy	Stud Kit	PTO Model	Torq	Dir Rot	Engine %		Filler Block	Adapter Assy	Stud Kit
	I / C †		Fwd	Rev					I / C †		Fwd	Rev			

REAR MOUNT - MECHANICAL SHIFT

524XMDAX-***	300	Eng	81	Furnished	Furnished
524XTDAX-***	300	Eng	106	Furnished	Furnished
524XUDAX-***	300	Eng	116	Furnished	Furnished

Mercedes/Daimler/Detroit

† I = Intermittent Torque Only - De-rate Torque Rating 30% for Continuous Duty.

C = Continuous or Intermittent Torque - No need to De-Rate Torque Rating.

IMPORTANT: Refer to the back of this transmission section and read all notes associated with this application page. Some notes may affect the proper PTO selection.

CAUTION: The default data code for the DT12 PTO is "split low" upon PTO activation. Speeds are shown in Low Split. For High Split multiply speed shown by 1.289.

CAUTION: Included shims for 330025X input adapter kit are required for installation.

CAUTION: Maximum allowable yoke swing diameter is 180 mm. There is suitable clearance between the 524 Series PTO and the Meritor RPL35 flange however the RPL25 yoke prohibits mounting a 524 PTO. 524 Series PTOs for this application ship with a sculpted housing.

CAUTION: The maximum allowable bending moment for direct mounted pumps is 354 lb-inch (29.5 lb-ft) [40 Nm] w/o bracket. Refer to DT12 PTO Installation Guide DDC-ENG-MAN-0001.

CHELSEA®

MERCEDES/DAIMLER/DETROIT

M/B-11B

DT12-DHL (DT12-DB, G 211-12)

REAR SIDE ONLY

TRANSMISSION GEAR DATA:
REAR 04-BOLT Opening

PITCH LINE TO APERTURE FACE:
0" (0MM)

CAUTION: Application Approval Required for PTO Output Shaft Speeds Above 2500 RPM

PTO Model	Torq	Dir Rot	Engine %		Filler Block	Adapter Assy	Stud Kit	PTO Model	Torq	Dir Rot	Engine %		Filler Block	Adapter Assy	Stud Kit
	I / C †		Fwd	Rev					I / C †		Fwd	Rev			

REAR MOUNT - MECHANICAL SHIFT

524XMDBX-**-**	300	Eng	81					524XMDBX-**-**	300	Eng	81					Furnished	Furnished
524XTDBX-**-**	300	Eng	106					524XTDBX-**-**	300	Eng	106					Furnished	Furnished
524XUDBX-**-**	300	Eng	116					524XUDBX-**-**	300	Eng	116					Furnished	Furnished

† I = Intermittent Torque Only - De-rate Torque Rating 30% for Continuous Duty.

C = Continuous or Intermittent Torque - No need to De-Rate Torque Rating.

IMPORTANT: Refer to the back of this transmission section and read all notes associated with this application page. Some notes may affect the proper PTO selection.

CAUTION: The default data code for the DT12 PTO is "split low" upon PTO activation. Speeds are shown in Low Split. For High Split multiply speed shown by 1.289.

CAUTION: Included shims for 330003X input adapter kit are required for installation.

CAUTION: Maximum allowable yoke swing diameter is 180 mm. There is suitable clearance between the 524 Series PTO and the Meritor RPL35 flange however the RPL25 yoke prohibits mounting a 524 PTO. 524 Series PTOs for this application ship with a sculpted housing.

CAUTION: The maximum allowable bending moment for direct mounted pumps is 354 lb-inch (29.5 lb-ft) [40 Nm] w/o bracket. Refer to DT12 PTO Installation Guide DDC-ENG-MAN-0001.

Mercedes/Daimler/Detroit

M/B-12

MERCEDES/DAIMLER/DETROIT



DT12-OHE (DT12-OC, G 320-12)
DT12-OV (DT12-OC, G 320-12)

BOTTOM SIDE ONLY **REAR SIDE ONLY**

TRANSMISSION GEAR DATA:
BOT 08-BOLT Opening Gear REAR of Centerline
39 Teeth - L.H. HELIX
PITCH LINE TO APERTURE FACE:
5.2" (132.000MM)

TRANSMISSION GEAR DATA:
REAR 04-BOLT Opening
PITCH LINE TO APERTURE FACE:
0" (0MM)

CAUTION: Application Approval Required for PTO Output Shaft Speeds Above 2500 RPM

PTO Model	Torq	Dir Rot	Engine %		Filler Block	Adapter Assy	Stud Kit	PTO Model	Torq	Dir Rot	Engine %		Filler Block	Adapter Assy	Stud Kit
	I / C †		Fwd	Rev					I / C †		Fwd	Rev			

ONE SPEED - TWO GEAR - MECHANICAL SHIFT

489DAMAX-*6 (2)	250 I	Opp	70			Furnished	Furnished
489DFMAX-*6 (3)	250 I	Opp	111			Furnished	Furnished
489DLMAX-*6 (1)	250 I	Opp	143			Furnished	Furnished
489DQMAX-*6 (1)	225 I	Opp	154			Furnished	Furnished
489DRMAX-*6 (1)	225 I	Opp	179			Furnished	Furnished
680DFMAX-*6 (10)	375 I	Opp	111			Furnished	Furnished
823DGMAX-*6 (7)	750 I	Opp	97			Furnished	Furnished
823DMMAX-*6 (8)	750 I	Opp	135			Furnished	Furnished
823DRMAX-*6 (9)	550 I	Opp	186			Furnished	Furnished
880DGMAX-*6 (4)	500 I	Opp	97			Furnished	Furnished
880DMMAX-*6 (5)	500 I	Opp	135			Furnished	Furnished
880DRMAX-*6 (6)	400 I	Opp	186			Furnished	Furnished

REAR MOUNT - MECHANICAL SHIFT

524XMDDX-*-**	300	Eng	95			Furnished	Furnished
524XTDDX-*-**	300	Eng	126			Furnished	Furnished
524XVDDX-*-**	258	Eng	170			Furnished	Furnished

† I = Intermittent Torque Only - De-rate Torque Rating 30% for Continuous Duty.

C = Continuous or Intermittent Torque - No need to De-Rate Torque Rating.

IMPORTANT: Refer to the back of this transmission section and read all notes associated with this application page. Some notes may affect the proper PTO selection.

CAUTION: Effective August 2021, 489 / 680 Series with a 5 shift option (double-acting shifter) are approved for all applications.

CAUTION: For rear mount applications only, the default data code for the DT12 PTO is "split low" upon PTO activation. Speeds are shown in Low Split. For High Split multiply speed shown by 1.289.

CAUTION: DD inputs requires usage of supplied PTO lube kit (330057X). Failure to install this kit will result in PTO and/or transmission damage.

- (1) Input Gear Part No. 5-P-1596
- (2) Input Gear Part No. 5-P-1605
- (3) Input Gear Part No. 5-P-1607
- (4) Input Gear Part No. 5-P-1619
- (5) Input Gear Part No. 5-P-1621
- (6) Input Gear Part No. 5-P-1623
- (7) Input Gear Part No. 5-P-1638
- (8) Input Gear Part No. 5-P-1640
- (9) Input Gear Part No. 5-P-1641
- (10) Input Gear Part No. 5-P-1678

Mercedes/Daimler/Detroit



October 2022
5.11.10

Parker Hannifin Corporation
Chelsea Products Division
Olive Branch, MS 38654 USA

DT12-DHE (DT12-DC, G 271-12)
DT12-DV (DT12-DC, G 271-12)

BOTTOM SIDE ONLY	REAR SIDE ONLY
TRANSMISSION GEAR DATA: BOT 08-BOLT Opening Gear REAR of Centerline 30 Teeth - L.H. HELIX PITCH LINE TO APERTURE FACE: 6" (152.143MM)	TRANSMISSION GEAR DATA: REAR 04-BOLT Opening PITCH LINE TO APERTURE FACE: 0" (0MM)

CAUTION: Application Approval Required for PTO Output Shaft Speeds Above 2500 RPM

PTO Model	Torq	Dir Rot	Engine %		Filler Block	Adapter Assy	Stud Kit	PTO Model	Torq	Dir Rot	Engine %		Filler Block	Adapter Assy	Stud Kit
	I / C †		Fwd	Rev					I / C †		Fwd	Rev			
ONE SPEED - TWO GEAR - MECHANICAL SHIFT															
489DCMBX-*6 (2)	250 I	Opp	69			Furnished	Furnished								
489DLMBX-*6 (1)	250 I	Opp	110			Furnished	Furnished								
489DQMBX-*6 (1)	225 I	Opp	119			Furnished	Furnished								
489DRMBX-*6 (1)	225 I	Opp	138			Furnished	Furnished								
489DSMBX-*6 (1)	200 I	Opp	164			Furnished	Furnished								
489DUMBX-*6 (1)	195 I	Opp	195			Furnished	Furnished								
680DQMBX-*6 (9)	375 I	Opp	119			Furnished	Furnished								
823DMMBX-*6 (5)	750 I	Opp	103			Furnished	Furnished								
823DRMBX-*6 (6)	550 I	Opp	143			Furnished	Furnished								
823DTMBX-*6 (7)	500 I	Opp	184			Furnished	Furnished								
880DMMBX-*6 (3)	500 I	Opp	103			Furnished	Furnished								
880DQMBX-*6 (4)	450 I	Opp	121			Furnished	Furnished								
880DTMBX-*6 (8)	350 I	Opp	184			Furnished	Furnished								

REAR MOUNT - MECHANICAL SHIFT

524XMDDX-*.*	300	Eng	86			Furnished	Furnished
524XTDDX-*.*	300	Eng	114			Furnished	Furnished
524XVDDX-*.*	258	Eng	154			Furnished	Furnished

† I = Intermittent Torque Only - De-rate Torque Rating 30% for Continuous Duty. C = Continuous or Intermittent Torque - No need to De-Rate Torque Rating.

IMPORTANT: Refer to the back of this transmission section and read all notes associated with this application page. Some notes may affect the proper PTO selection.

CAUTION: Effective August 2021, 489 / 680 Series with a 5 shift option (double-acting shifter) are approved for all applications.

CAUTION: For rear mount applications only, the default data code for the DT12 PTO is "split low" upon PTO activation. Speeds are shown in Low Split. For High Split multiply speed shown by 1.289.

CAUTION: DD inputs requires usage of supplied PTO lube kit (330057X). Failure to install this kit will result in PTO and/or transmission damage.

- (1) Input Gear Part No. 5-P-1599 (6) Input Gear Part No. 5-P-1648
- (2) Input Gear Part No. 5-P-1610 (7) Input Gear Part No. 5-P-1649
- (3) Input Gear Part No. 5-P-1627 (8) Input Gear Part No. 5-P-1658
- (4) Input Gear Part No. 5-P-1628 (9) Input Gear Part No. 5-P-1679
- (5) Input Gear Part No. 5-P-1647

M/B-14

MERCEDES/DAIMLER/DETROIT

CHELSEA®

DT12-OVX (DT12-OD, G 340-12)

BOTTOM SIDE ONLY

REAR SIDE ONLY

TRANSMISSION GEAR DATA:

BOT 08-BOLT Opening Gear REAR of Centerline
40 Teeth - L.H. HELIX

PITCH LINE TO APERTURE FACE:
5.2" (131.068MM)

TRANSMISSION GEAR DATA:

REAR 04-BOLT Opening

PITCH LINE TO APERTURE FACE:
0" (0MM)

CAUTION: Application Approval Required for PTO Output Shaft Speeds Above 2500 RPM

PTO Model	Torq	Dir Rot	Engine %		Filler Block	Adapter Assy	Stud Kit	PTO Model	Torq	Dir Rot	Engine %		Filler Block	Adapter Assy	Stud Kit
	I / C †		Fwd	Rev					I / C †		Fwd	Rev			

ONE SPEED - TWO GEAR - MECHANICAL SHIFT

489DAMCX-*6 (2)	250 I	Opp	68			Furnished	Furnished								
489DFMCX-*6 (3)	250 I	Opp	108			Furnished	Furnished								
489DLMCX-*6 (1)	250 I	Opp	140			Furnished	Furnished								
489DQMCX-*6 (1)	225 I	Opp	151			Furnished	Furnished								
489DRMCX-*6 (1)	225 I	Opp	175			Furnished	Furnished								
489DSMCX-*6 (1)	200 I	Opp	208			Furnished	Furnished								
680DFMCX-*6 (10)	375 I	Opp	108			Furnished	Furnished								
823DGMCX-*6 (7)	750 I	Opp	97			Furnished	Furnished								
823DMMCX-*6 (8)	750 I	Opp	133			Furnished	Furnished								
823DRMCX-*6 (9)	550 I	Opp	184			Furnished	Furnished								
880DGMCX-*6 (4)	500 I	Opp	97			Furnished	Furnished								
880DMMCX-*6 (5)	500 I	Opp	133			Furnished	Furnished								
880DRMCX-*6 (6)	400 I	Opp	184			Furnished	Furnished								

REAR MOUNT - MECHANICAL SHIFT

524XMDDX-*6**	300	Eng	97			Furnished	Furnished
524XTDDX-*6**	300	Eng	129			Furnished	Furnished
524XVDDX-*6**	258	Opp	175			Furnished	Furnished

† I = Intermittent Torque Only - De-rate Torque Rating 30% for Continuous Duty.

C = Continuous or Intermittent Torque - No need to De-Rate Torque Rating.

IMPORTANT: Refer to the back of this transmission section and read all notes associated with this application page. Some notes may affect the proper PTO selection.

CAUTION: Effective August 2021, 489 / 680 Series with a 5 shift option (double-acting shifter) are approved for all applications.

CAUTION: For rear mount applications only, the default data code for the DT12 PTO is "split low" upon PTO activation. Speeds are shown in Low Split. For High Split multiply speed shown by 1.289.

CAUTION: DD inputs requires usage of supplied PTO lube kit (330057X). Failure to install this kit will result in PTO and/or transmission damage.

- (1) Input Gear Part No. 5-P-1601
- (2) Input Gear Part No. 5-P-1613
- (3) Input Gear Part No. 5-P-1615
- (4) Input Gear Part No. 5-P-1631
- (5) Input Gear Part No. 5-P-1633
- (6) Input Gear Part No. 5-P-1635
- (7) Input Gear Part No. 5-P-1652
- (8) Input Gear Part No. 5-P-1654
- (9) Input Gear Part No. 5-P-1655
- (10) Input Gear Part No. 5-P-1680

Mercedes/Daimler/Detroit Notes

M/B-5

1. PTO Right Side Only for transmission models AMT3-520-6DA, MBT520-6DA and MBT520-6D. No Rear Mount Option.
-

M/B-6

1. PTO Right Side Only for transmission models AMT3-660-6OA, MBTT660-6OA and MBT660S-6O. No Rear Mount Option.
-

M/B-10B

1. 524 Series DB input option includes 330003X input adapter kit.
 2. Rear mount provisions must be ordered from factory and enabled for the chassis.
-

M/B-10A

1. 524 Series DA input option includes 330025X input adapter kit.
 2. Rear mount provisions must be ordered from factory and enabled for the chassis.
-

M/B-11A

1. 524 Series DA input option includes 330025X input adapter kit.
 2. Rear mount provisions must be ordered from factory and enabled for the chassis.
-

M/B-11B

1. 524 Series DB input option includes 330003X input adapter kit.
 2. Rear mount provisions must be ordered from factory and enabled for the chassis.
-

M/B-12

1. 489 Series MA input option includes 329932X input adapter kit.
 2. 680, 880, and 823 Series MA input option includes 330032X input adapter kit.
 3. 524 Series DD input option includes 330061X input adapter kit.
 4. Included shims for 330061X input adapter kit are NOT REQUIRED for installation.
 5. Rear mount provisions must be ordered from factory and enabled for the chassis.
 6. For simultaneous operation of dual PTOs refer to DT12 PTO Installation Guide DDC-ENG-MAN-0001.
-

M/B-13

1. 489 Series MB input option includes 329954X input adapter kit.
 2. 680, 880 and 823 Series MB input option includes 330033X input adapter kit.
 3. 524 Series DD input option includes 330061X input adapter kit.
 4. Included shims for 330061X input adapter kit are NOT REQUIRED for installation.
 5. Rear mount provisions must be ordered from factory and enabled for the chassis.
 6. For simultaneous operation of dual PTOs refer to DT12 PTO Installation Guide DDC-ENG-MAN-0001.
-

M/B-14

1. 489 Series MC input option includes 329955X input adapter kit.
 2. 680, 880 and 823 Series MC input option includes 330034X input adapter kit.
 3. 524 Series DD input option includes 330061X input adapter kit.
 4. Included shims for 330061X input adapter kit are NOT REQUIRED for installation.
 5. Rear mount provisions must be ordered from factory and enabled for the chassis.
 6. For simultaneous operation of dual PTOs refer to DT12 PTO Installation Guide DDC-ENG-MAN-0001.
-



MERITOR/R/ROCKWELL

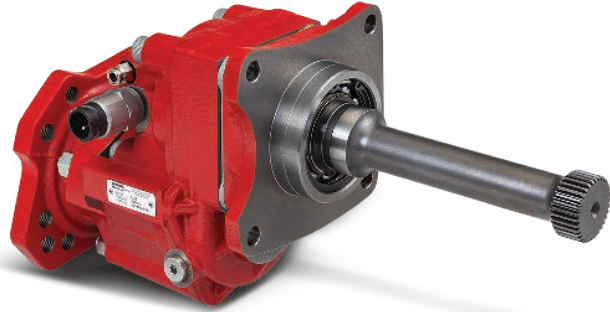
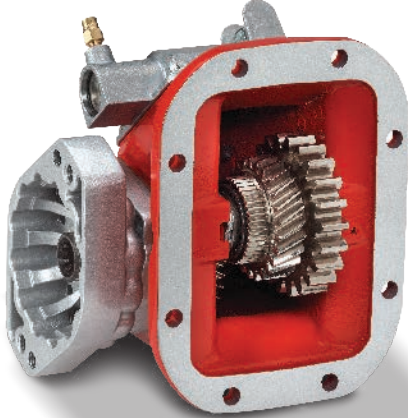
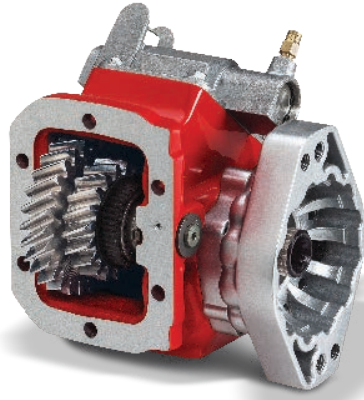



WARNING — User Responsibility

FAILURE OR IMPROPER SELECTION OR IMPROPER USE OF THE PRODUCTS DESCRIBED HEREIN OR RELATED ITEMS CAN CAUSE DEATH, PERSONAL INJURY AND PROPERTY DAMAGE.

This document and other information from Parker Hannifin Corporation, its subsidiaries and authorized distributors provide product or system options for further investigation by users having technical expertise.

The user, through its own analysis and testing, is solely responsible for making the final selection of the system and components and assuring that all performance, endurance, maintenance, safety and warning requirements of the application are met. The user must analyze all aspects of the application, follow applicable industry standards, and follow the information concerning the product in the current product catalog and in any other materials provided from Parker or its subsidiaries or authorized distributors.

To the extent that Parker or its subsidiaries or authorized distributors provide component or system options based upon data or specifications provided by the user, the user is responsible for determining that such data and specifications are suitable and sufficient for all applications and reasonably foreseeable uses of the components or systems.

Offer of Sale

The items described in this document are hereby offered for sale by Parker Hannifin Corporation, its subsidiaries or its authorized distributors. This offer and its acceptance are governed by the provisions stated in the "Offer of Sale".



WARNING: This product can expose you to chemicals including Lead and Lead Compounds, and Di(2-ethylhexyl)phthalate (DEHP) which are known to the State of California to cause cancer and birth defects or other reproductive harm. For more information go to www.P65Warnings.ca.gov

© Copyright 2022, Parker Hannifin Corporation, All Rights Reserved

MERITOR/ROCKWELL TRANSMISSION INDEX

Transmission Make and Model	PTO Appl. Number	Number Forward Speeds	Teeth in PTO Driver
M-11F10A-E11	RKW-1	10	R45-B45
M-11F10A-S11	RKW-1	10	R45-B45
M-11F9A-E11	RKW-1	9	R45-B45
M-11F9A-S11	RKW-1	9	R45-B45
M-11G10A-D11	RKW-1	10	R45-B45
M-11G10A-E11	RKW-1	10	R45-B45
M-11G10A-M11	RKW-1	10	R45-B45
M-11G10A-S11	RKW-1	10	R45-B45
M-11G9A-D11	RKW-1	9	R45-B45
M-11G9A-E11	RKW-1	9	R45-B45
M-11G9A-M11	RKW-1	9	R45-B45
M-11G9A-S11	RKW-1	9	R45-B45
M-12F10A-E12	RKW-1	10	R45-B45
M-12F10A-S12	RKW-1	10	R45-B45
M-12F9A-E12	RKW-1	9	R45-B45
M-12F9A-S12	RKW-1	9	R45-B45
M-12G10A-D12	RKW-1	10	R45-B45
M-12G10A-E12	RKW-1	10	R45-B45
M-12G10A-M12	RKW-1	10	R45-B45
M-12G10A-S12	RKW-1	10	R45-B45
M-12G9A-D12	RKW-1	9	R45-B45
M-12G9A-E12	RKW-1	9	R45-B45
M-12G9A-M12	RKW-1	9	R45-B45
M-12G9A-S12	RKW-1	9	R45-B45
M-13F10A-E13	RKW-1	10	R45-B45
M-13F10A-S13	RKW-1	10	R45-B45
M-13F9A-E13	RKW-1	9	R45-B45
M-13F9A-S13	RKW-1	9	R45-B45
M-13G10A-D13	RKW-1	10	R45-B45
M-13G10A-E13	RKW-1	10	R45-B45
M-13G10A-M13	RKW-1	10	R45-B45
M-13G10A-S13	RKW-1	10	R45-B45
M-13G9A-D13	RKW-1	9	R45-B45
M-13G9A-E13	RKW-1	9	R45-B45
M-13G9A-M13	RKW-1	9	R45-B45
M-13G9A-S13	RKW-1	9	R45-B45

Meritor/Rockwell



IMPORTANT: See Safety Information in Section 1 of the Chelsea Applications catalog HY25-3000/US

Transmission PTO Driver & Apertures (Viewed from Rear of Transmission)
L-Left Side R-Right Side B-Bottom Side T-Top Side CS-Countershaft
For transmissions not listed, contact your authorized Chelsea Distributor.

MERITOR/ROCKWELL TRANSMISSION INDEX

Transmission Make and Model	PTO Appl. Number	Number Forward Speeds	Teeth in PTO Driver
M-13Z12A-A13 (Rear Mount PTO)	ZFM-5	12	CS
M-13Z12A-A14 (Rear Mount PTO)	ZFM-5	12	CS
M-14F10A-E14	RKW-1	10	R45-B45
M-14F10A-M16	RKW-1	10	R45-B45
M-14F10A-S14	RKW-1	10	R45-B45
M-14F10A-S15	RKW-1	10	R45-B45
M-14F9A-E14	RKW-1	9	R45-B45
M-14F9A-S14	RKW-1	9	R45-B45
M-14G10A-D14	RKW-1	10	R45-B45
M-14G10A-E14	RKW-1	10	R45-B45
M-14G10A-E16	RKW-1	10	R45-B45
M-14G10A-M14	RKW-1	10	R45-B45
M-14G10A-M16	RKW-1	10	R45-B45
M-14G10A-S14	RKW-1	10	R45-B45
M-14G9A-D14	RKW-1	9	R45-B45
M-14G9A-E14	RKW-1	9	R45-B45
M-14G9A-M14	RKW-1	9	R45-B45
M-14G9A-S14	RKW-1	9	R45-B45
M-14Z12A-A14 (Rear Mount PTO)	ZFM-5	12	CS
M-15F10A-E15	RKW-1	10	R45-B45
M-15F10A-S15	RKW-1	10	R45-B45
M-15G10A-D15	RKW-1	10	R45-B45
M-15G10A-E15	RKW-1	10	R45-B45
M-15G10A-M15	RKW-1	10	R45-B45
M-15G10A-S15	RKW-1	10	R45-B45
MO-11F10A-S11	RKW-2	10	R45-B45
MO-11F10C-E11	RKW-4	10	R45-B45
MO-11F10C-S11	RKW-4	10	R45-B45
MO-11F9B-E11	RKW-3	9	R45-B45
MO-11F9B-S11	RKW-3	9	R45-B45
MO-11G10A-D11	RKW-2	10	R45-B45
MO-11G10A-E11	RKW-2	10	R45-B45
MO-11G10A-M11	RKW-2	10	R45-B45
MO-11G10A-S11	RKW-2	10	R45-B45
MO-11G10C-D11	RKW-4	10	R45-B45
MO-11G10C-E11	RKW-4	10	R45-B45



IMPORTANT: See Safety Information
in Section 1 of the Chelsea Applications
catalog HY25-3000/US

Transmission PTO Driver & Apertures (Viewed from Rear of Transmission)
L-Left Side R-Right Side B-Bottom Side T-Top Side CS-Countershaft
For transmissions not listed, contact your authorized Chelsea Distributor.

MERITOR/ROCKWELL TRANSMISSION INDEX

Transmission Make and Model	PTO Appl. Number	Number Forward Speeds	Teeth in PTO Driver
MO-11G10C-M11	RKW-4	10	R45-B45
MO-11G10C-S11	RKW-4	10	R45-B45
MO-11G9B-D11	RKW-3	9	R45-B45
MO-11G9B-E11	RKW-3	9	R45-B45
MO-11G9B-M11	RKW-3	9	R45-B45
MO-11G9B-S11	RKW-3	9	R45-B45
MO-12F10A-E12	RKW-2	10	R45-B45
MO-12F10A-S12	RKW-2	10	R45-B45
MO-12F10C-E12	RKW-4	10	R45-B45
MO-12F10C-S12	RKW-4	10	R45-B45
MO-12F9A-E12	RKW-2	9	R45-B45
MO-12F9A-S12	RKW-2	9	R45-B45
MO-12F9B-E12	RKW-3	9	R45-B45
MO-12F9B-S12	RKW-3	9	R45-B45
MO-12G10A-D12	RKW-2	10	R45-B45
MO-12G10A-E12	RKW-2	10	R45-B45
MO-12G10A-M12	RKW-2	10	R45-B45
MO-12G10A-S12	RKW-2	10	R45-B45
MO-12G10C-D12	RKW-4	10	R45-B45
MO-12G10C-E12	RKW-4	10	R45-B45
MO-12G10C-M12	RKW-4	10	R45-B45
MO-12G10C-S12	RKW-4	10	R45-B45
MO-12G9A-D12	RKW-2	9	R45-B45
MO-12G9A-E12	RKW-2	9	R45-B45
MO-12G9A-M12	RKW-2	9	R45-B45
MO-12G9A-S12	RKW-2	9	R45-B45
MO-12G9B-D12	RKW-3	9	R45-B45
MO-12G9B-E12	RKW-3	9	R45-B45
MO-12G9B-M12	RKW-3	9	R45-B45
MO-12G9B-S12	RKW-3	9	R45-B45
MO-13F10A-E13	RKW-2	10	R45-B45
MO-13F10A-S13	RKW-2	10	R45-B45
MO-13F10C-E13	RKW-4	10	R45-B45
MO-13F10C-S13	RKW-4	10	R45-B45
MO-13F9A-E13	RKW-2	9	R45-B45
MO-13F9A-S13	RKW-2	9	R45-B45



IMPORTANT: See Safety Information in Section 1 of the Chelsea Applications catalog HY25-3000/US

Transmission PTO Driver & Apertures (Viewed from Rear of Transmission)
L-Left Side R-Right Side B-Bottom Side T-Top Side CS-Countershaft
For transmissions not listed, contact your authorized Chelsea Distributor.

MERITOR/ROCKWELL TRANSMISSION INDEX

Transmission Make and Model	PTO Appl. Number	Number Forward Speeds	Teeth in PTO Driver
MO-13F9B-E13	RKW-3	9	R45-B45
MO-13F9B-S13	RKW-3	9	R45-B45
MO-13G10A-D13	RKW-2	10	R45-B45
MO-13G10A-E13	RKW-2	10	R45-B45
MO-13G10A-M13	RKW-2	10	R45-B45
MO-13G10A-S13	RKW-2	10	R45-B45
MO-13G10C-D13	RKW-4	10	R45-B45
MO-13G10C-E13	RKW-4	10	R45-B45
MO-13G10C-M13	RKW-4	10	R45-B45
MO-13G10C-S13	RKW-4	10	R45-B45
MO-13G9A-D13	RKW-2	9	R45-B45
MO-13G9A-E13	RKW-2	9	R45-B45
MO-13G9A-M13	RKW-2	9	R45-B45
MO-13G9A-S13	RKW-2	9	R45-B45
MO-13G9B-D13	RKW-3	9	R45-B45
MO-13G9B-E13	RKW-3	9	R45-B45
MO-13G9B-M13	RKW-3	9	R45-B45
MO-13G9B-S13	RKW-3	9	R45-B45
MO-13Z12A-A13 (Rear Mount PTO)	ZFM-6	12	CS
MO-13Z12A-A14 (Rear Mount PTO)	ZFM-6	12	CS
MO-13Z16A-A13 (Rear Mount PTO)	ZFM-7	16	CS
MO-13Z16A-A14 (Rear Mount PTO)	ZFM-7	16	CS
MO-14F10A-E14	RKW-2	10	R45-B45
MO-14F10A-E16	RKW-2	10	R45-B45
MO-14F10A-M16	RKW-2	10	R45-B45
MO-14F10A-S14	RKW-2	10	R45-B45
MO-14F10A-S16	RKW-2	10	R45-B45
MO-14F10C-E14	RKW-4	10	R45-B45
MO-14F10C-E16	RKW-4	10	R45-B45
MO-14F10C-M16	RKW-4	10	R45-B45
MO-14F10C-S14	RKW-4	10	R45-B45
MO-14F10C-S16	RKW-4	10	R45-B45
MO-14F9A-E14	RKW-2	9	R45-B45
MO-14F9A-S14	RKW-2	9	R45-B45
MO-14F9B-E14	RKW-3	9	R45-B45
MO-14F9B-S14	RKW-3	9	R45-B45



IMPORTANT: See Safety Information
in Section 1 of the Chelsea Applications
catalog HY25-3000/US

Transmission PTO Driver & Apertures (Viewed from Rear of Transmission)
L-Left Side R-Right Side B-Bottom Side T-Top Side CS-Countershaft
For transmissions not listed, contact your authorized Chelsea Distributor.

MERITOR/ROCKWELL TRANSMISSION INDEX

Transmission Make and Model	PTO Appl. Number	Number Forward Speeds	Teeth in PTO Driver
MO-14G10A-D14	RKW-2	10	R45-B45
MO-14G10A-E14	RKW-2	10	R45-B45
MO-14G10A-E16	RKW-2	10	R45-B45
MO-14G10A-M14	RKW-2	10	R45-B45
MO-14G10A-M16	RKW-2	10	R45-B45
MO-14G10A-S14	RKW-2	10	R45-B45
MO-14G10A-S16	RKW-2	10	R45-B45
MO-14G10C-D14	RKW-4	10	R45-B45
MO-14G10C-E14	RKW-4	10	R45-B45
MO-14G10C-E16	RKW-4	10	R45-B45
MO-14G10C-M14	RKW-4	10	R45-B45
MO-14G10C-M16	RKW-4	10	R45-B45
MO-14G10C-S14	RKW-4	10	R45-B45
MO-14G10C-S16	RKW-4	10	R45-B45
MO-14G9A-D14	RKW-2	9	R45-B45
MO-14G9A-E14	RKW-2	9	R45-B45
MO-14G9A-M14	RKW-2	9	R45-B45
MO-14G9A-S14	RKW-2	9	R45-B45
MO-14G9B-D14	RKW-3	9	R45-B45
MO-14G9B-E14	RKW-3	9	R45-B45
MO-14G9B-M14	RKW-3	9	R45-B45
MO-14G9B-S14	RKW-3	9	R45-B45
MO-14Z12A-A14 (Rear Mount PTO)	ZFM-6	12	CS
MO-14Z12A-A16 (Rear Mount PTO)	ZFM-6	12	CS
MO-14Z16A-A14 (Rear Mount PTO)	ZFM-7	16	CS
MO-14Z16A-A16 (Rear Mount PTO)	ZFM-7	16	CS
MO-15F10A-E15	RKW-2	10	R45-B45
MO-15F10A-S15	RKW-2	10	R45-B45
MO-15F10C-E15	RKW-4	10	R45-B45
MO-15F10C-S15	RKW-4	10	R45-B45
MO-15F9B-E15	RKW-3	9	R45-B45
MO-15F9B-S15	RKW-3	9	R45-B45
MO-15G10A-D15	RKW-2	10	R45-B45
MO-15G10A-E15	RKW-2	10	R45-B45
MO-15G10A-M15	RKW-2	10	R45-B45
MO-15G10A-S15	RKW-2	10	R45-B45

Meritor/Rockwell



IMPORTANT: See Safety Information in Section 1 of the Chelsea Applications catalog HY25-3000/US

Transmission PTO Driver & Apertures (Viewed from Rear of Transmission)
L-Left Side R-Right Side B-Bottom Side T-Top Side CS-Countershaft
For transmissions not listed, contact your authorized Chelsea Distributor.

MERITOR/ROCKWELL TRANSMISSION INDEX

Transmission Make and Model	PTO Appl. Number	Number Forward Speeds	Teeth in PTO Driver
MO-15G10C-D15	RKW-4	10	R45-B45
MO-15G10C-E15	RKW-4	10	R45-B45
MO-15G10C-M15	RKW-4	10	R45-B45
MO-15G10C-S15	RKW-4	10	R45-B45
MO-15G9B-D15	RKW-3	9	R45-B45
MO-15G9B-E15	RKW-3	9	R45-B45
MO-15G9B-M15	RKW-3	9	R45-B45
MO-15G9B-S15	RKW-3	9	R45-B45
MO-15Z12A-A15 (Rear Mount PTO)	ZFM-6	12	CS
MO-15Z12A-A16 (Rear Mount PTO)	ZFM-6	12	CS
MO-15Z16A-A15 (Rear Mount PTO)	ZFM-7	16	CS
MO-15Z16A-A16 (Rear Mount PTO)	ZFM-7	16	CS
MO-16F10A-E16	RKW-2	10	R45-B45
MO-16F10A-S16	RKW-2	10	R45-B45
MO-16F10C-E16	RKW-4	10	R45-B45
MO-16F10C-E18	RKW-4	10	R45-B45
MO-16F10C-M18	RKW-4	10	R45-B45
MO-16F10C-S16	RKW-4	10	R45-B45
MO-16F10C-S18	RKW-4	10	R45-B45
MO-16G10A-D16	RKW-2	10	R45-B45
MO-16G10A-E16	RKW-2	10	R45-B45
MO-16G10A-M16	RKW-2	10	R45-B45
MO-16G10A-S16	RKW-2	10	R45-B45
MO-16G10C-D16	RKW-4	10	R45-B45
MO-16G10C-E16	RKW-4	10	R45-B45
MO-16G10C-E18	RKW-4	10	R45-B45
MO-16G10C-M16	RKW-4	10	R45-B45
MO-16G10C-M18	RKW-4	10	R45-B45
MO-16G10C-S16	RKW-4	10	R45-B45
MO-16G10C-S18	RKW-4	10	R45-B45
MO-16Z12A-A16 (Rear Mount PTO)	ZFM-6	12	CS
MO-16Z16A-A16 (Rear Mount PTO)	ZFM-7	16	CS
RD10-145A	RKW-1	10	R45-B45
RE10-115A	RKW-1	10	R45-B45
RE10-125A	RKW-1	10	R45-B45
RE10-135A	RKW-1	10	R45-B45



IMPORTANT: See Safety Information
in Section 1 of the Chelsea Applications
catalog HY25-3000/US

Transmission PTO Driver & Apertures (Viewed from Rear of Transmission)
L-Left Side R-Right Side B-Bottom Side T-Top Side CS-Countershaft
For transmissions not listed, contact your authorized Chelsea Distributor.

MERITOR/ROCKWELL TRANSMISSION INDEX

Transmission Make and Model	PTO Appl. Number	Number Forward Speeds	Teeth in PTO Driver
RE10-145A	RKW-1	10	R45-B45
RE10-155A	RKW-1	10	R45-B45
RE9-115A	RKW-1	9	R45-B45
RE9-125A	RKW-1	9	R45-B45
RE9-135A	RKW-1	9	R45-B45
RE9-145A	RKW-1	9	R45-B45
RE9-155A	RKW-1	9	R45-B45
REO9-115B	RKW-3	9	R45-B45
REO9-125A	RKW-2	9	R45-B45
REO9-125B	RKW-3	9	R45-B45
REO9-135A	RKW-2	9	R45-B45
REO9-135B	RKW-3	9	R45-B45
REO9-145A	RKW-2	9	R45-B45
REO9-145B	RKW-3	9	R45-B45
REO9-155B	RKW-3	9	R45-B45
REX10-115A	RKW-2	10	R45-B45
REX10-115C	RKW-4	10	R45-B45
REX10-125A	RKW-2	10	R45-B45
REX10-125C	RKW-4	10	R45-B45
REX10-135A	RKW-2	10	R45-B45
REX10-135C	RKW-4	10	R45-B45
REX10-145A	RKW-2	10	R45-B45
REX10-145C	RKW-4	10	R45-B45
REX10-155A	RKW-2	10	R45-B45
REX10-155C	RKW-4	10	R45-B45
REX10-165A	RKW-2	10	R45-B45
REX10-165C	RKW-4	10	R45-B45
REX9-115B	RKW-3	9	R45-B45
REX9-115R	RKW-3	9	R45-B45
REX9-125A	RKW-2	9	R45-B45
REX9-125B	RKW-3	9	R45-B45
REX9-125R	RKW-3	9	R45-B45
REX9-135A	RKW-2	9	R45-B45
REX9-135B	RKW-3	9	R45-B45
REX9-135R	RKW-3	9	R45-B45
REX9-145A	RKW-2	9	R45-B45



IMPORTANT: See Safety Information in Section 1 of the Chelsea Applications catalog HY25-3000/US

Transmission PTO Driver & Apertures (Viewed from Rear of Transmission)
L-Left Side R-Right Side B-Bottom Side T-Top Side CS-Countershaft
For transmissions not listed, contact your authorized Chelsea Distributor.

MERITOR/ROCKWELL TRANSMISSION INDEX

Transmission Make and Model	PTO Appl. Number	Number Forward Speeds	Teeth in PTO Driver
REX9-145B	RKW-3	9	R45-B45
REX9-145R	RKW-3	9	R45-B45
REX9-155B	RKW-3	9	R45-B45
RM10-115A	RKW-1	10	R45-B45
RM10-125A	RKW-1	10	R45-B45
RM10-135A	RKW-1	10	R45-B45
RM10-145A	RKW-1	10	R45-B45
RM10-155A	RKW-1	10	R45-B45
RM9-115A	RKW-1	9	R45-B45
RM9-125A	RKW-1	9	R45-B45
RM9-135A	RKW-1	9	R45-B45
RM9-145A	RKW-1	9	R45-B45
RM9-155A	RKW-1	9	R45-B45
RMO13-145A	RKW-1	13	R45-B45
RMO9-115A	RKW-2	9	R45-B45
RMO9-115B	RKW-3	9	R45-B45
RMO9-125A	RKW-2	9	R45-B45
RMO9-125B	RKW-3	9	R45-B45
RMO9-135A	RKW-2	9	R45-B45
RMO9-135B	RKW-3	9	R45-B45
RMO9-145A	RKW-2	9	R45-B45
RMO9-145B	RKW-3	9	R45-B45
RMO9-155B	RKW-3	9	R45-B45
RMX10-115A	RKW-2	10	R45-B45
RMX10-115C	RKW-4	10	R45-B45
RMX10-125A	RKW-2	10	R45-B45
RMX10-125C	RKW-4	10	R45-B45
RMX10-135A	RKW-2	10	R45-B45
RMX10-135C	RKW-4	10	R45-B45
RMX10-145A	RKW-2	10	R45-B45
RMX10-145C	RKW-4	10	R45-B45
RMX10-155A	RKW-2	10	R45-B45
RMX10-155C	RKW-4	10	R45-B45
RMX10-165A	RKW-2	10	R45-B45
RMX10-165C	RKW-4	10	R45-B45
RMX9-115B	RKW-3	9	R45-B45



IMPORTANT: See Safety Information
in Section 1 of the Chelsea Applications
catalog HY25-3000/US

Transmission PTO Driver & Apertures (Viewed from Rear of Transmission)
L-Left Side R-Right Side B-Bottom Side T-Top Side CS-Countershaft
For transmissions not listed, contact your authorized Chelsea Distributor.

MERITOR/ROCKWELL TRANSMISSION INDEX

Transmission Make and Model	PTO Appl. Number	Number Forward Speeds	Teeth in PTO Driver
RMX9-115R	RKW-2	9	R45-B45
RMX9-125A	RKW-2	9	R45-B45
RMX9-125B	RKW-3	9	R45-B45
RMX9-125R	RKW-2	9	R45-B45
RMX9-135A	RKW-2	9	R45-B45
RMX9-135B	RKW-3	9	R45-B45
RMX9-135R	RKW-2	9	R45-B45
RMX9-145A	RKW-2	9	R45-B45
RMX9-145B	RKW-3	9	R45-B45
RMX9-145R	RKW-2	9	R45-B45
RMX9-155B	RKW-3	9	R45-B45
RS10-115A	RKW-1	10	R45-B45
RS10-125A	RKW-1	10	R45-B45
RS10-135A	RKW-1	10	R45-B45
RS10-145A	RKW-1	10	R45-B45
RS10-155A	RKW-1	10	R45-B45
RS9-115A	RKW-1	9	R45-B45
RS9-125A	RKW-1	9	R45-B45
RS9-135A	RKW-1	9	R45-B45
RS9-145A	RKW-1	9	R45-B45
RS9-155A	RKW-1	9	R45-B45
RSO9-115B	RKW-3	9	R45-B45
RSO9-125B	RKW-3	9	R45-B45
RSO9-135B	RKW-3	9	R45-B45
RSO9-145B	RKW-3	9	R45-B45
RSO9-155B	RKW-3	9	R45-B45
RSX10-115A	RKW-2	10	R45-B45
RSX10-115C	RKW-4	10	R45-B45
RSX10-125A	RKW-2	10	R45-B45
RSX10-125C	RKW-4	10	R45-B45
RSX10-135A	RKW-2	10	R45-B45
RSX10-135C	RKW-4	10	R45-B45
RSX10-145A	RKW-2	10	R45-B45
RSX10-145C	RKW-4	10	R45-B45
RSX10-155A	RKW-2	10	R45-B45
RSX10-155C	RKW-4	10	R45-B45

Meritor/Rockwell



IMPORTANT: See Safety Information in Section 1 of the Chelsea Applications catalog HY25-3000/US

Transmission PTO Driver & Apertures (Viewed from Rear of Transmission)
L-Left Side R-Right Side B-Bottom Side T-Top Side CS-Countershaft
For transmissions not listed, contact your authorized Chelsea Distributor.

MERITOR/ROCKWELL TRANSMISSION INDEX

Transmission Make and Model	PTO Appl. Number	Number Forward Speeds	Teeth in PTO Driver
RSX10-165A	RKW-2	10	R45-B45
RSX10-165C	RKW-4	10	R45-B45
RSX9-115B	RKW-3	9	R45-B45
RSX9-115C	RKW-3	9	R45-B45
RSX9-115R	RKW-3	9	R45-B45
RSX9-125A	RKW-2	9	R45-B45
RSX9-125B	RKW-3	9	R45-B45
RSX9-125C	RKW-3	9	R45-B45
RSX9-125R	RKW-2	9	R45-B45
RSX9-135A	RKW-2	9	R45-B45
RSX9-135B	RKW-3	9	R45-B45
RSX9-135C	RKW-3	9	R45-B45
RSX9-135R	RKW-2	9	R45-B45
RSX9-145A	RKW-2	9	R45-B45
RSX9-145B	RKW-3	9	R45-B45
RSX9-145C	RKW-3	9	R45-B45
RSX9-145R	RKW-2	9	R45-B45
RSX9-155B	RKW-3	9	R45-B45
RSX9-155C	RKW-3	9	R45-B45
RSX9-165C	RKW-3	9	R45-B45



IMPORTANT: See Safety Information
in Section 1 of the Chelsea Applications
catalog HY25-3000/US

Transmission PTO Driver & Apertures (Viewed from Rear of Transmission)
L-Left Side R-Right Side B-Bottom Side T-Top Side CS-Countershaft
For transmissions not listed, contact your authorized Chelsea Distributor.

CHELSEA®

MERITOR/ROCKWELL

RKW-1

M-11F10A-E11 M-11F10A-S11 M-11F9A-E11 M-11F9A-S11 M-11G10A-D11 M-11G10A-E11 M-11G10A-M11 M-11G10A-S11	M-11G9A-D11 M-11G9A-E11 M-11G9A-M11 M-11G9A-S11 M-12F10A-E12 M-12F10A-S12 M-12F9A-E12 M-12F9A-S12	M-12G10A-D12 M-12G10A-E12 M-12G10A-M12 M-12G10A-S12 M-12G9A-D12 M-12G9A-E12 M-12G9A-M12 M-12G9A-S12
--	--	--

BOTTOM SIDE ONLY	RIGHT SIDE ONLY
TRANSMISSION GEAR DATA: BOT 08-BOLT Opening Gear FORWARD of Centerline 45 Teeth - SPUR PITCH LINE TO APERTURE FACE: 0.8100" (20.5740MM)	TRANSMISSION GEAR DATA: R.S. 06-BOLT Opening Gear FORWARD of Centerline 45 Teeth - SPUR PITCH LINE TO APERTURE FACE: 1.0850" (27.5600MM)

CAUTION: Application Approval Required for PTO Output Shaft Speeds Above 2500 RPM

PTO Model	Torq I / C †	Dir Rot	Engine %		Filler Block	Adapter Assy	Stud Kit	PTO Model	Torq I / C †	Dir Rot	Engine %		Filler Block	Adapter Assy	Stud Kit
			Fwd	Rev							Fwd	Rev			

ONE SPEED - TWO GEAR - MECHANICAL SHIFT

221ZCAHX-*3	250 I	Opp	63		7-A-032(P)(46)	328564X	Furnished	221XCAHX-*3	250 I	Opp	63		7-A-032(46)		Furnished
221ZEAHX-*3	250 I	Opp	73			328564X	Furnished	221XEAHX-*3	250 I	Opp	73				Furnished
489XAAHX-*5 (12)	250 I	Opp	56				Furnished	442XAAHX-*3 (12)	250 I	Opp	56				Furnished
489XCAHX-*5 (13)	250 I	Opp	71				Furnished	442XBAHX-*3 (18)	250 I	Eng	56			REQUIRED	Furnished
489XFAHX-*5 (2)	250 I	Opp	88				Furnished	442XCAHX-*3 (13)	250 I	Opp	71				Furnished
489XHAHX-*5 (15)	250 I	Opp	102				Furnished	442XFAHX-*3 (2)	250 I	Opp	88				Furnished
489XLAHX-*5 (1)	250 I	Opp	114				Furnished	442XHAHX-*3 (15)	250 I	Opp	102				Furnished
489XQAHX-*5 (1)	225 I	Opp	123				Furnished	442XLAHX-*3 (1)	250 I	Opp	114				Furnished
489XRAHX-*5 (1)	225 I	Opp	142				Furnished	442XQAHX-*3 (1)	225 I	Opp	123				Furnished
489XSAHX-*5 (1)	200 I	Opp	169				Furnished	442XRAHX-*3 (1)	225 I	Opp	142				Furnished
489XUAHX-*5 (1)	195 I	Opp	202				Furnished	442XSAHX-*3 (1)	200 I	Opp	169				Furnished
489XWAHX-*5 (1)	175 I	Opp	237				Furnished	442XUAHX-*3 (1)	195 I	Opp	201				Furnished
489XXAHX-*5 (1)	140 I	Opp	281				Furnished	442XWAHX-*3 (1)	175 I	Opp	237				Furnished
680XFAHX-*3 (10)	375 I	Opp	88				Furnished	442XXAHX-*3 (1)	140 I	Opp	280				Furnished
680XHAHX-*3 (20)	375 I	Opp	102				Furnished	660XFAHX-*3 (10)	375 I	Opp	88				Furnished
680XQAHX-*3 (11)	375 I	Opp	123				Furnished	660XHAHX-*3 (15)	375 I	Opp	102				Furnished
680XRAHX-*3 (19)	350 I	Opp	142				Furnished	660XQAHX-*3 (11)	375 I	Opp	123				Furnished
680XSAHX-*3 (14)	325 I	Opp	169				Furnished	660XRAHX-*3 (19)	350 I	Opp	142				Furnished
823XBAHX-*3 (40)	500 I	Opp	60				Furnished	660XSAHX-*3 (14)	325 I	Opp	169				Furnished
823XDAHX-*3 (44)	500 I	Opp	71				Furnished								
823XGAHX-*3 (45)	500 I	Opp	77				Furnished								
823XJAHX-*3 (41)	500 I	Opp	91				Furnished								
823XMAHX-*3 (39)	500 I	Opp	107				Furnished								
823XRAHX-*3 (43)	400 I	Opp	147				Furnished								
823XTKTX-*3 (17)	350 I	Opp	177		8-A-165(46)		Furnished								
880XBAHX-*3 (3)	500 I	Opp	60				Furnished								
880XDAHX-*3 (4)	500 I	Opp	71				Furnished								
880XGAHX-*3 (9)	500 I	Opp	77				Furnished								
880XJAHX-*3 (5)	500 I	Opp	91				Furnished								
880XMAHX-*3 (6)	500 I	Opp	107				Furnished								
880XQAHX-*3 (16)	450 I	Opp	125				Furnished								

Continued on Next Page

† I = Intermittent Torque Only - De-rate Torque Rating 30% for Continuous Duty.

C = Continuous or Intermittent Torque - No need to De-Rate Torque Rating.

IMPORTANT: Refer to the back of this transmission section and read all notes associated with this application page. Some notes may affect the proper PTO selection.

- (1) Input Gear Part No. 5-P-1004
- (2) Input Gear Part No. 5-P-1077
- (3) Input Gear Part No. 5-P-1100
- (4) Input Gear Part No. 5-P-1101
- (5) Input Gear Part No. 5-P-1102
- (6) Input Gear Part No. 5-P-1103

- (9) Input Gear Part No. 5-P-1135
- (10) Input Gear Part No. 5-P-1242
- (11) Input Gear Part No. 5-P-1246
- (12) Input Gear Part No. 5-P-1280
- (13) Input Gear Part No. 5-P-1287
- (14) Input Gear Part No. 5-P-1322

- (15) Input Gear Part No. 5-P-1364
- (16) Input Gear Part No. 5-P-1385
- (17) Input Gear Part No. 5-P-1395
- (18) Input Gear Part No. 5-P-1418
- (19) Input Gear Part No. 5-P-1441
- (20) Input Gear Part No. 5-P-1494

- (39) Input Gear Part No. 5-P-283
- (40) Input Gear Part No. 5-P-285
- (41) Input Gear Part No. 5-P-325
- (43) Input Gear Part No. 5-P-721
- (44) Input Gear Part No. 5-P-971
- (45) Input Gear Part No. 5-P-980

(46) Filler block furnished with PTO

RKW-1

MERITOR/ROCKWELL



M-11F10A-E11	M-11G9A-D11	M-12G10A-D12
M-11F10A-S11	M-11G9A-E11	M-12G10A-E12
M-11F9A-E11	M-11G9A-M11	M-12G10A-M12
M-11F9A-S11	M-11G9A-S11	M-12G10A-S12
M-11G10A-D11	M-12F10A-E12	M-12G9A-D12
M-11G10A-E11	M-12F10A-S12	M-12G9A-E12
M-11G10A-M11	M-12F9A-E12	M-12G9A-M12
M-11G10A-S11	M-12F9A-S12	M-12G9A-S12

BOTTOM SIDE ONLY	RIGHT SIDE ONLY
TRANSMISSION GEAR DATA: BOT 08-BOLT Opening Gear FORWARD of Centerline 45 Teeth - SPUR PITCH LINE TO APERTURE FACE: 0.8100" (20.5740MM)	TRANSMISSION GEAR DATA: R.S. 06-BOLT Opening Gear FORWARD of Centerline 45 Teeth - SPUR PITCH LINE TO APERTURE FACE: 1.0850" (27.5600MM)

CAUTION: Application Approval Required for PTO Output Shaft Speeds Above 2500 RPM

PTO Model	Torq l / C †	Dir Rot	Engine %		Filler Block	Adapter Assy	Stud Kit	PTO Model	Torq l / C †	Dir Rot	Engine %		Filler Block	Adapter Assy	Stud Kit
			Fwd	Rev							Fwd	Rev			

ONE SPEED - TWO GEAR - MECHANICAL SHIFT

880XRAHX-*3 (7)	400 l	Opp	147				Furnished								
880XTAHX-*3 (8)	350 l	Opp	189				Furnished								

ONE SPEED - TWO GEAR POWERSHIFT (AIR OR HYDRAULIC)

272XAAJX-*3 (30)	250 C	Opp	49			328481X	Furnished	272XAAJX-*3 (30)	250 C	Opp	49				Furnished
282XBAJX-*3 (21)	250 C	Opp	60		8-A-032		Furnished	272XBAJX-*3 (31)	250 C	Opp	60				Furnished
282XCAJX-*3 (22)	250 C	Opp	73		8-A-032		Furnished	272XCAJX-*3 (32)	250 C	Opp	73				Furnished
282XDAJX-*3 (23)	250 C	Opp	87		8-A-032		Furnished	272XDAJX-*3 (33)	250 C	Opp	87				Furnished
282XGAJX-*3 (24)	250 C	Opp	103		8-A-032		Furnished	272XGAJX-*3 (34)	250 C	Opp	103				Furnished
282XKAJX-*3 (25)	250 C	Opp	115		8-A-032		Furnished	272XMAJX-*3 (36)	250 C	Opp	129				Furnished
282XMAJX-*3 (26)	250 C	Opp	129		8-A-032		Furnished	272XPAJX-*3 (37)	250 C	Opp	144				Furnished
282XPAJX-*3 (27)	250 C	Opp	144		8-A-032		Furnished	272XSAJX-*3 (38)	225 C	Opp	161				Furnished
282XSAJX-*3 (28)	225 C	Opp	161		8-A-032		Furnished								
282XTAJX-*3 (29)	225 C	Opp	180		8-A-032		Furnished								

ONE SPEED - POWERSHIFT LOW PROFILE (AIR OR HYDRAULIC)

272MAAJX-*3 (30)	250 C	Opp	49			328481X	Furnished	272MAAJX-*3 (30)	250 C	Opp	49				Furnished
								272MBAJX-*3 (31)	250 C	Opp	60				Furnished
								272MCAJX-*3 (32)	250 C	Opp	73				Furnished
								272MDAJX-*3 (33)	250 C	Opp	87				Furnished
								272MGAJX-*3 (34)	250 C	Opp	103				Furnished
								272MKAJX-*3 (35)	250 C	Opp	115				Furnished
								272MMAJX-*3 (36)	250 C	Opp	129				Furnished
								272MPAJX-*3 (37)	250 C	Opp	144				Furnished
								272MSAJX-*3 (38)	225 C	Opp	161				Furnished

ONE SPEED - TWO GEAR - POWERSHIFT (AIR)

885XBAHX-*3 (3)	500 l	Opp	60				Furnished								
885XGAHX-*3 (9)	500 l	Opp	77				Furnished								
885XJAHX-*3 (5)	500 l	Opp	91				Furnished								
885XMAHX-*3 (6)	500 l	Opp	107				Furnished								

Continued on Next Page

† I = Intermittent Torque Only - De-rate Torque Rating 30% for Continuous Duty. C = Continuous or Intermittent Torque - No need to De-Rate Torque Rating.

IMPORTANT: Refer to the back of this transmission section and read all notes associated with this application page. Some notes may affect the proper PTO selection.

- | | | | |
|----------------------------------|---------------------------------------|---------------------------------------|--------------------------------------|
| (3) Input Gear Part No. 5-P-1100 | (21) Input Gear Part No. 5-P-1510-11X | (27) Input Gear Part No. 5-P-1510-17X | (33) Input Gear Part No. 5-P-1510-4X |
| (5) Input Gear Part No. 5-P-1102 | (22) Input Gear Part No. 5-P-1510-12X | (28) Input Gear Part No. 5-P-1510-18X | (34) Input Gear Part No. 5-P-1510-5X |
| (6) Input Gear Part No. 5-P-1103 | (23) Input Gear Part No. 5-P-1510-13X | (29) Input Gear Part No. 5-P-1510-19X | (35) Input Gear Part No. 5-P-1510-6X |
| (7) Input Gear Part No. 5-P-1104 | (24) Input Gear Part No. 5-P-1510-14X | (30) Input Gear Part No. 5-P-1510-1X | (36) Input Gear Part No. 5-P-1510-7X |
| (8) Input Gear Part No. 5-P-1105 | (25) Input Gear Part No. 5-P-1510-15X | (31) Input Gear Part No. 5-P-1510-2X | (37) Input Gear Part No. 5-P-1510-8X |
| (9) Input Gear Part No. 5-P-1135 | (26) Input Gear Part No. 5-P-1510-16X | (32) Input Gear Part No. 5-P-1510-3X | (38) Input Gear Part No. 5-P-1510-9X |

Meritor/Rockwell



October 2022
5.12.12

Parker Hannifin Corporation
Chelsea Products Division
Olive Branch, MS 38654 USA

CHELSEA®

MERITOR/ROCKWELL

RKW-1

M-11F10A-E11	M-11G9A-D11	M-12G10A-D12
M-11F10A-S11	M-11G9A-E11	M-12G10A-E12
M-11F9A-E11	M-11G9A-M11	M-12G10A-M12
M-11F9A-S11	M-11G9A-S11	M-12G10A-S12
M-11G10A-D11	M-12F10A-E12	M-12G9A-D12
M-11G10A-E11	M-12F10A-S12	M-12G9A-E12
M-11G10A-M11	M-12F9A-E12	M-12G9A-M12
M-11G10A-S11	M-12F9A-S12	M-12G9A-S12

BOTTOM SIDE ONLY	RIGHT SIDE ONLY
-------------------------	------------------------

<p>TRANSMISSION GEAR DATA: BOT 08-BOLT Opening Gear FORWARD of Centerline 45 Teeth - SPUR PITCH LINE TO APERTURE FACE: 0.8100" (20.5740MM)</p>	<p>TRANSMISSION GEAR DATA: R.S. 06-BOLT Opening Gear FORWARD of Centerline 45 Teeth - SPUR PITCH LINE TO APERTURE FACE: 1.0850" (27.5600MM)</p>
--	---

CAUTION: Application Approval Required for PTO Output Shaft Speeds Above 2500 RPM

PTO Model	Torq	Dir Rot	Engine %		Filler Block	Adapter Assy	Stud Kit	PTO Model	Torq	Dir Rot	Engine %		Filler Block	Adapter Assy	Stud Kit
	I / C †		Fwd	Rev					I / C †		Fwd	Rev			

ONE SPEED - TWO GEAR - FORWARD & REVERSE

348XFAHX-*5 (42)	200 I	Opp	77	81			Furnished	340XFAHX-*5 (42)	200 I	Opp	77	81	7-A-140(46)		Furnished
863XBAHX-*5	500 I	Opp	60	74			Furnished								

GEARED ADAPTERS

628XAHX-3AH	250 I	Eng					Furnished	626XAHX-3AH	250 I	Eng					Furnished
								630XAHX-3AH	250 I	Eng					Furnished
								645XAHX-3AH	250 I	Eng					Furnished

† I = Intermittent Torque Only - De-rate Torque Rating 30% for Continuous Duty.

C = Continuous or Intermittent Torque - No need to De-Rate Torque Rating.

IMPORTANT: Refer to the back of this transmission section and read all notes associated with this application page. Some notes may affect the proper PTO selection.

(42) Input Gear Part No. 5-P-581
(46) Filler block furnished with PTO

RKW-2

MERITOR/ROCKWELL



MO-11F10A-S11 MO-11G10A-D11 MO-11G10A-E11 MO-11G10A-M11 MO-11G10A-S11 MO-12F10A-E12 MO-12F10A-S12 MO-12F9A-E12	MO-12F9A-S12 MO-12G10A-D12 MO-12G10A-E12 MO-12G10A-M12 MO-12G10A-S12 MO-12G9A-D12 MO-12G9A-E12 MO-12G9A-M12	MO-12G9A-S12 MO-13F10A-E13 MO-13F10A-S13 MO-13F9A-E13 MO-13F9A-S13 MO-13G10A-D13 MO-13G10A-E13 MO-13G10A-M13
---	--	---

BOTTOM SIDE ONLY	RIGHT SIDE ONLY
-------------------------	------------------------

<p>TRANSMISSION GEAR DATA: BOT 08-BOLT Opening Gear FORWARD of Centerline 45 Teeth - SPUR</p> <p>PITCH LINE TO APERTURE FACE: 0.8100" (20.5740MM)</p>	<p>TRANSMISSION GEAR DATA: R.S. 06-BOLT Opening Gear FORWARD of Centerline 45 Teeth - SPUR</p> <p>PITCH LINE TO APERTURE FACE: 1.0850" (27.5600MM)</p>
---	--

CAUTION: Application Approval Required for PTO Output Shaft Speeds Above 2500 RPM

PTO Model	Torq I / C †	Dir Rot	Engine %		Filler Block	Adapter Assy	Stud Kit	PTO Model	Torq I / C †	Dir Rot	Engine %		Filler Block	Adapter Assy	Stud Kit
			Fwd	Rev							Fwd	Rev			

ONE SPEED - TWO GEAR - MECHANICAL SHIFT

221ZCAHX-*3	250 I	Opp	85		7-A-032(P)(45)	328564X	Furnished	221XCAHX-*3	250 I	Opp	85		7-A-032(45)		Furnished
221ZEAHX-*3	250 I	Opp	98			328564X	Furnished	221XEAHX-*3	250 I	Opp	98				Furnished
489XAAHX-*5 (12)	250 I	Opp	75				Furnished	442XAAHX-*3 (12)	250 I	Opp	75				Furnished
489XCAHX-*5 (13)	250 I	Opp	96				Furnished	442XBAHX-*3 (18)	250 I	Opp	75			REQUIRED	Furnished
489XFAHX-*5 (2)	250 I	Opp	118				Furnished	442XCAHX-*3 (13)	250 I	Opp	96				Furnished
489XHAHX-*5 (15)	250 I	Opp	137				Furnished	442XFAHX-*3 (2)	250 I	Opp	118				Furnished
489XLAHX-*5 (1)	250 I	Opp	153				Furnished	442XHAHX-*3 (15)	250 I	Opp	137				Furnished
489XQAHX-*5 (1)	225 I	Opp	165				Furnished	442XLAHX-*3 (1)	250 I	Opp	153				Furnished
489XRAHX-*5 (1)	225 I	Opp	191				Furnished	442XQAHX-*3 (1)	225 I	Opp	165				Furnished
489XSAHX-*5 (1)	200 I	Opp	227				Furnished	442XRAHX-*3 (1)	225 I	Opp	191				Furnished
489XUAHX-*5 (1)	195 I	Opp	270				Furnished	442XSAHX-*3 (1)	200 I	Opp	227				Furnished
489XWAHX-*5 (1)	175 I	Opp	318				Furnished	442XUAHX-*3 (1)	195 I	Opp	270				Furnished
489XXAHX-*5 (1)	140 I	Opp	376				Furnished	442XWAHX-*3 (1)	175 I	Opp	318				Furnished
680XFAHX-*3 (10)	375 I	Opp	118				Furnished	442XXAHX-*3 (1)	140 I	Opp	376				Furnished
680XHAHX-*3 (20)	375 I	Opp	137				Furnished	660XFAHX-*3 (10)	375 I	Opp	118				Furnished
680XQAHX-*3 (11)	375 I	Opp	165				Furnished	660XHAHX-*3 (15)	375 I	Opp	137				Furnished
680XRAHX-*3 (19)	350 I	Opp	191				Furnished	660XQAHX-*3 (11)	375 I	Opp	165				Furnished
680XSAHX-*3 (14)	325 I	Opp	227				Furnished	660XRAHX-*3 (19)	350 I	Opp	191				Furnished
823XBAHX-*3 (39)	500 I	Opp	80				Furnished	660XSAHX-*3 (14)	325 I	Opp	227				Furnished
823XDAHX-*3 (43)	500 I	Opp	95				Furnished								
823XGAHX-*3 (44)	500 I	Opp	103				Furnished								
823XJAHX-*3 (40)	500 I	Opp	122				Furnished								
823XMAHX-*3 (38)	500 I	Opp	143				Furnished								
823XRAHX-*3 (42)	400 I	Opp	197				Furnished								
823XTKTX-*3 (17)	350 I	Opp	239		8-A-165(45)		Furnished								
880XBAHX-*3 (3)	500 I	Opp	80				Furnished								
880XDAHX-*3 (4)	500 I	Opp	95				Furnished								
880XGAHX-*3 (9)	500 I	Opp	104				Furnished								
880XJAHX-*3 (5)	500 I	Opp	122				Furnished								
880XMAHX-*3 (6)	500 I	Opp	143				Furnished								
880XQAHX-*3 (16)	450 I	Opp	167				Furnished								

Continued on Next Page

† I = Intermittent Torque Only - De-rate Torque Rating 30% for Continuous Duty. C = Continuous or Intermittent Torque - No need to De-Rate Torque Rating.

IMPORTANT: Refer to the back of this transmission section and read all notes associated with this application page. Some notes may affect the proper PTO selection.

CAUTION: Do not use geared adapters with 442 A and C ratios.

- | | | | | |
|----------------------------------|-----------------------------------|-----------------------------------|----------------------------------|--------------------------------------|
| (1) Input Gear Part No. 5-P-1004 | (9) Input Gear Part No. 5-P-1135 | (15) Input Gear Part No. 5-P-1364 | (38) Input Gear Part No. 5-P-283 | (45) Filler block furnished with PTO |
| (2) Input Gear Part No. 5-P-1077 | (10) Input Gear Part No. 5-P-1242 | (16) Input Gear Part No. 5-P-1385 | (39) Input Gear Part No. 5-P-285 | |
| (3) Input Gear Part No. 5-P-1100 | (11) Input Gear Part No. 5-P-1246 | (17) Input Gear Part No. 5-P-1395 | (40) Input Gear Part No. 5-P-325 | |
| (4) Input Gear Part No. 5-P-1101 | (12) Input Gear Part No. 5-P-1280 | (18) Input Gear Part No. 5-P-1418 | (42) Input Gear Part No. 5-P-721 | |
| (5) Input Gear Part No. 5-P-1102 | (13) Input Gear Part No. 5-P-1287 | (19) Input Gear Part No. 5-P-1441 | (43) Input Gear Part No. 5-P-971 | |
| (6) Input Gear Part No. 5-P-1103 | (14) Input Gear Part No. 5-P-1322 | (20) Input Gear Part No. 5-P-1494 | (44) Input Gear Part No. 5-P-980 | |

Meritor/Rockwell



October 2022
5.12.14

Parker Hannifin Corporation
Chelsea Products Division
Olive Branch, MS 38654 USA

MO-11F10A-S11 MO-11G10A-D11 MO-11G10A-E11 MO-11G10A-M11 MO-11G10A-S11 MO-12F10A-E12 MO-12F10A-S12 MO-12F9A-E12	MO-12F9A-S12 MO-12G10A-D12 MO-12G10A-E12 MO-12G10A-M12 MO-12G10A-S12 MO-12G9A-D12 MO-12G9A-E12 MO-12G9A-M12	MO-12G9A-S12 MO-13F10A-E13 MO-13F10A-S13 MO-13F9A-E13 MO-13F9A-S13 MO-13G10A-D13 MO-13G10A-E13 MO-13G10A-M13
---	--	---

BOTTOM SIDE ONLY	RIGHT SIDE ONLY
TRANSMISSION GEAR DATA: BOT 08-BOLT Opening Gear FORWARD of Centerline 45 Teeth - SPUR PITCH LINE TO APERTURE FACE: 0.8100" (20.5740MM)	TRANSMISSION GEAR DATA: R.S. 06-BOLT Opening Gear FORWARD of Centerline 45 Teeth - SPUR PITCH LINE TO APERTURE FACE: 1.0850" (27.5600MM)

CAUTION: Application Approval Required for PTO Output Shaft Speeds Above 2500 RPM

PTO Model	Torq I / C †	Dir Rot	Engine %		Filler Block	Adapter Assy	Stud Kit	PTO Model	Torq I / C †	Dir Rot	Engine %		Filler Block	Adapter Assy	Stud Kit
			Fwd	Rev							Fwd	Rev			

ONE SPEED - TWO GEAR - MECHANICAL SHIFT

880XRAHX-*3 (7)	400 I	Opp	197				Furnished								
880XTAHX-*3 (8)	350 I	Opp	254				Furnished								

ONE SPEED - TWO GEAR POWERSHIFT (AIR OR HYDRAULIC)

272XAAJX-*3 (29)	250 C	Opp	66			328481X	Furnished	272XAAJX-*3 (29)	250 C	Opp	66				Furnished
282XBAJX-*3 (21)	250 C	Opp	80	8-A-032			Furnished	272XBAJX-*3 (30)	250 C	Opp	80				Furnished
282XCAJX-*3 (22)	250 C	Opp	97	8-A-032			Furnished	272XCAJX-*3 (31)	250 C	Opp	97				Furnished
282XDAJX-*3 (23)	250 C	Opp	116	8-A-032			Furnished	272XDAJX-*3 (32)	250 C	Opp	116				Furnished
282XGAJX-*3 (24)	250 C	Opp	138	8-A-032			Furnished	272XGAJX-*3 (33)	250 C	Opp	138				Furnished
282XKAJX-*3 (25)	250 C	Opp	155	8-A-032			Furnished	272XKAJX-*3 (34)	250 C	Opp	155				Furnished
282XMAJX-*3 (26)	250 C	Opp	173	8-A-032			Furnished	272XMAJX-*3 (35)	250 C	Opp	173				Furnished
282XPAJX-*3 (27)	250 C	Opp	193	8-A-032			Furnished	272XPAJX-*3 (36)	250 C	Opp	193				Furnished
282XSAJX-*3 (28)	225 C	Opp	216	8-A-032			Furnished	272XSAJX-*3 (37)	225 C	Opp	216				Furnished

ONE SPEED - POWERSHIFT LOW PROFILE (AIR OR HYDRAULIC)

272MAAJX-*3 (29)	250 C	Opp	66			328481X	Furnished	272MAAJX-*3 (29)	250 C	Opp	66				Furnished
								272MBAJX-*3 (30)	250 C	Opp	80				Furnished
								272MCAJX-*3 (31)	250 C	Opp	97				Furnished
								272MDAJX-*3 (32)	250 C	Opp	116				Furnished
								272MGAJX-*3 (33)	250 C	Opp	138				Furnished
								272MKAJX-*3 (34)	250 C	Opp	155				Furnished
								272MMAJX-*3 (35)	250 C	Opp	173				Furnished
								272MPAJX-*3 (36)	250 C	Opp	193				Furnished

ONE SPEED - TWO GEAR - POWERSHIFT (AIR)

885XBAHX-*3 (3)	500 I	Opp	80				Furnished								
885XGAHX-*3 (9)	500 I	Opp	104				Furnished								
885XJAHX-*3 (5)	500 I	Opp	122				Furnished								
885XMAHX-*3 (6)	500 I	Opp	143				Furnished								

ONE SPEED - FORWARD & REVERSE

Continued on Next Page

† I = Intermittent Torque Only - De-rate Torque Rating 30% for Continuous Duty. C = Continuous or Intermittent Torque - No need to De-Rate Torque Rating.

IMPORTANT: Refer to the back of this transmission section and read all notes associated with this application page. Some notes may affect the proper PTO selection.

CAUTION: Do not use geared adapters with 442 A and C ratios.

- (3) Input Gear Part No. 5-P-1100
- (5) Input Gear Part No. 5-P-1102
- (6) Input Gear Part No. 5-P-1103
- (7) Input Gear Part No. 5-P-1104
- (8) Input Gear Part No. 5-P-1105
- (9) Input Gear Part No. 5-P-1135

- (21) Input Gear Part No. 5-P-1510-11X
- (22) Input Gear Part No. 5-P-1510-12X
- (23) Input Gear Part No. 5-P-1510-13X
- (24) Input Gear Part No. 5-P-1510-14X
- (25) Input Gear Part No. 5-P-1510-15X
- (26) Input Gear Part No. 5-P-1510-16X

- (27) Input Gear Part No. 5-P-1510-17X
- (28) Input Gear Part No. 5-P-1510-18X
- (29) Input Gear Part No. 5-P-1510-1X
- (30) Input Gear Part No. 5-P-1510-2X
- (31) Input Gear Part No. 5-P-1510-3X
- (32) Input Gear Part No. 5-P-1510-4X

- (33) Input Gear Part No. 5-P-1510-5X
- (34) Input Gear Part No. 5-P-1510-6X
- (35) Input Gear Part No. 5-P-1510-7X
- (36) Input Gear Part No. 5-P-1510-8X
- (37) Input Gear Part No. 5-P-1510-9X

RKW-2

MERITOR/ROCKWELL



MO-11F10A-S11	MO-12F9A-S12	MO-12G9A-S12
MO-11G10A-D11	MO-12G10A-D12	MO-13F10A-E13
MO-11G10A-E11	MO-12G10A-E12	MO-13F10A-S13
MO-11G10A-M11	MO-12G10A-M12	MO-13F9A-E13
MO-11G10A-S11	MO-12G10A-S12	MO-13F9A-S13
MO-12F10A-E12	MO-12G9A-D12	MO-13G10A-D13
MO-12F10A-S12	MO-12G9A-E12	MO-13G10A-E13
MO-12F9A-E12	MO-12G9A-M12	MO-13G10A-M13

BOTTOM SIDE ONLY	RIGHT SIDE ONLY
-------------------------	------------------------

<p>TRANSMISSION GEAR DATA: BOT 08-BOLT Opening Gear FORWARD of Centerline 45 Teeth - SPUR PITCH LINE TO APERTURE FACE: 0.8100" (20.5740MM)</p>	<p>TRANSMISSION GEAR DATA: R.S. 06-BOLT Opening Gear FORWARD of Centerline 45 Teeth - SPUR PITCH LINE TO APERTURE FACE: 1.0850" (27.5600MM)</p>
--	---

CAUTION: Application Approval Required for PTO Output Shaft Speeds Above 2500 RPM

PTO Model	Torq	Dir Rot	Engine %		Filler Block	Adapter Assy	Stud Kit	PTO Model	Torq	Dir Rot	Engine %		Filler Block	Adapter Assy	Stud Kit
	I / C †		Fwd	Rev					I / C †		Fwd	Rev			

ONE SPEED - FORWARD & REVERSE

348XFAHX-*5 (41)	200 I	Opp	103	108			Furnished	340XFAHX-*5 (41)	200 I	Opp	103	108	7-A-140(45)		Furnished
863XBAHX-*5	500 I	Opp	80	100			Furnished								

GEARED ADAPTERS

628XAHX-3AH	250 I	Eng					Furnished	626XAHX-3AH	250 I	Eng					Furnished
								630XAHX-3AH	250 I	Eng					Furnished
								645XAHX-3AH	250 I	Eng					Furnished

† I = Intermittent Torque Only - De-rate Torque Rating 30% for Continuous Duty.

C = Continuous or Intermittent Torque - No need to De-Rate Torque Rating.

IMPORTANT: Refer to the back of this transmission section and read all notes associated with this application page. Some notes may affect the proper PTO selection.

CAUTION: Do not use geared adapters with 442 A and C ratios.

(41) Input Gear Part No. 5-P-581
(45) Filler block furnished with PTO

MO-11F9B-E11	MO-12G9B-D12	MO-13G9B-M13
MO-11F9B-S11	MO-12G9B-E12	MO-13G9B-S13
MO-11G9B-D11	MO-12G9B-M12	MO-14F9B-E14
MO-11G9B-E11	MO-12G9B-S12	MO-14F9B-S14
MO-11G9B-M11	MO-13F9B-E13	MO-14G9B-D14
MO-11G9B-S11	MO-13F9B-S13	MO-14G9B-E14
MO-12F9B-E12	MO-13G9B-D13	MO-14G9B-M14
MO-12F9B-S12	MO-13G9B-E13	MO-14G9B-S14

BOTTOM SIDE ONLY	RIGHT SIDE ONLY
TRANSMISSION GEAR DATA: BOT 08-BOLT Opening Gear FORWARD of Centerline 45 Teeth - SPUR PITCH LINE TO APERTURE FACE: 0.8100" (20.5740MM)	TRANSMISSION GEAR DATA: R.S. 06-BOLT Opening Gear FORWARD of Centerline 45 Teeth - SPUR PITCH LINE TO APERTURE FACE: 1.0850" (27.5600MM)

CAUTION: Application Approval Required for PTO Output Shaft Speeds Above 2500 RPM

PTO Model	Torq I / C †	Dir Rot	Engine %		Filler Block	Adapter Assy	Stud Kit	PTO Model	Torq I / C †	Dir Rot	Engine %		Filler Block	Adapter Assy	Stud Kit
			Fwd	Rev							Fwd	Rev			

ONE SPEED - TWO GEAR - MECHANICAL SHIFT

489XAAHX-*5 (12)	250 I	Opp	64				Furnished	221XCAHX-*3	250 I	Eng	73	7-A-032(P)(46)	329138X	Furnished
489XCAHX-*5 (13)	250 I	Opp	82				Furnished	21XEAHX-*3	250 I	Eng	84		329138X	Furnished
489XFAHX-*5 (2)	250 I	Opp	101				Furnished	442XAAHX-*3 (12)	250 I	Opp	64			Furnished
489XHAHX-*5 (15)	250 I	Opp	117				Furnished	442XBAHX-*3 (18)	250 I	Eng	64		REQUIRED	Furnished
489XLAHX-*5 (1)	250 I	Opp	131				Furnished	442XCAHX-*3 (13)	250 I	Opp	82			Furnished
489XQAHX-*5 (1)	225 I	Opp	141				Furnished	442XFAHX-*3 (2)	250 I	Opp	101			Furnished
489XRAHX-*5 (1)	225 I	Opp	163				Furnished	442XHAHX-*3 (15)	250 I	Opp	117			Furnished
489XSAHX-*5 (1)	200 I	Opp	194				Furnished	442XLAHX-*3 (1)	250 I	Opp	131			Furnished
680XFAHX-*3 (10)	375 I	Opp	101				Furnished	442XQAHX-*3 (1)	225 I	Opp	141			Furnished
680XHAHX-*3 (20)	375 I	Opp	117				Furnished	442XRAHX-*3 (1)	225 I	Opp	163			Furnished
680XQAHX-*3 (11)	375 I	Opp	141				Furnished	442XSAHX-*3 (1)	200 I	Opp	194			Furnished
680XRAHX-*3 (19)	350 I	Opp	163				Furnished	660XFAHX-*3 (10)	375 I	Opp	101			Furnished
680XSAHX-*3 (14)	325 I	Opp	194				Furnished	660XHAHX-*3 (15)	375 I	Opp	117			Furnished
823XBAHX-*3 (40)	500 I	Opp	69				Furnished	660XQAHX-*3 (11)	375 I	Opp	141			Furnished
823XDAHX-*3 (44)	500 I	Opp	81				Furnished	660XRAHX-*3 (19)	350 I	Opp	163			Furnished
823XGAHX-*3 (45)	500 I	Opp	88				Furnished	660XSAHX-*3 (14)	325 I	Opp	194			Furnished
823XJAHX-*3 (41)	500 I	Opp	104				Furnished							
823XMAHX-*3 (39)	500 I	Opp	122				Furnished							
823XRAHX-*3 (43)	400 I	Opp	169				Furnished							
823XTKTX-*3 (17)	350 I	Opp	205	8-A-165(P)(46)			Furnished							
880XBAHX-*3 (3)	500 I	Opp	69				Furnished							
880XDAHX-*3 (4)	500 I	Opp	82				Furnished							
880XGAHX-*3 (9)	500 I	Opp	89				Furnished							
880XJAHX-*3 (5)	500 I	Opp	104				Furnished							
880XMAHX-*3 (6)	500 I	Opp	122				Furnished							
880XQAHX-*3 (16)	450 I	Opp	143				Furnished							
880XRAHX-*3 (7)	400 I	Opp	169				Furnished							
880XTAHX-*3 (8)	350 I	Opp	218				Furnished							

ONE SPEED - TWO GEAR POWERSHIFT (AIR OR HYDRAULIC)

272XAAJX-*3 (30)	250 C	Opp	56		328481X	Furnished	272XAAJX-*3 (30)	250 C	Opp	56				Furnished
282XBAJX-*3 (21)	250 C	Opp	69		8-A-032	Furnished	272XBAJX-*3 (31)	250 C	Opp	69				Furnished

Continued on Next Page

† I = Intermittent Torque Only - De-rate Torque Rating 30% for Continuous Duty.

C = Continuous or Intermittent Torque - No need to De-Rate Torque Rating.

IMPORTANT: Refer to the back of this transmission section and read all notes associated with this application page. Some notes may affect the proper PTO selection.

CAUTION: Do not use geared adapters with 442 A and C ratios.

- (1) Input Gear Part No. 5-P-1004
- (2) Input Gear Part No. 5-P-1077
- (3) Input Gear Part No. 5-P-1100
- (4) Input Gear Part No. 5-P-1101
- (5) Input Gear Part No. 5-P-1102
- (6) Input Gear Part No. 5-P-1103
- (7) Input Gear Part No. 5-P-1104

- (8) Input Gear Part No. 5-P-1105
- (9) Input Gear Part No. 5-P-1135
- (10) Input Gear Part No. 5-P-1242
- (11) Input Gear Part No. 5-P-1246
- (12) Input Gear Part No. 5-P-1280
- (13) Input Gear Part No. 5-P-1287
- (14) Input Gear Part No. 5-P-1322

- (15) Input Gear Part No. 5-P-1364
- (16) Input Gear Part No. 5-P-1385
- (17) Input Gear Part No. 5-P-1395
- (18) Input Gear Part No. 5-P-1418
- (19) Input Gear Part No. 5-P-1441
- (20) Input Gear Part No. 5-P-1494
- (21) Input Gear Part No. 5-P-1510-11X

- (30) Input Gear Part No. 5-P-1510-1X
- (31) Input Gear Part No. 5-P-1510-2X
- (39) Input Gear Part No. 5-P-283
- (40) Input Gear Part No. 5-P-285
- (41) Input Gear Part No. 5-P-325
- (43) Input Gear Part No. 5-P-721
- (44) Input Gear Part No. 5-P-971

- (45) Input Gear Part No. 5-P-980
- (46) Filler block furnished with PTO

RKW-3

MERITOR/ROCKWELL

CHELSEA®

MO-11F9B-E11
MO-11F9B-S11
MO-11G9B-D11
MO-11G9B-E11
MO-11G9B-M11
MO-11G9B-S11
MO-12F9B-E12
MO-12F9B-S12MO-12G9B-D12
MO-12G9B-E12
MO-12G9B-M12
MO-12G9B-S12
MO-13F9B-E13
MO-13F9B-S13
MO-13G9B-D13
MO-13G9B-E13MO-13G9B-M13
MO-13G9B-S13
MO-14F9B-E14
MO-14F9B-S14
MO-14G9B-D14
MO-14G9B-E14
MO-14G9B-M14
MO-14G9B-S14

BOTTOM SIDE ONLY

RIGHT SIDE ONLY

TRANSMISSION GEAR DATA:

BOT 08-BOLT Opening Gear FORWARD of Centerline
45 Teeth - SPUR

PITCH LINE TO APERTURE FACE:

0.8100" (20.5740MM)

TRANSMISSION GEAR DATA:

R.S. 06-BOLT Opening Gear FORWARD of Centerline
45 Teeth - SPUR

PITCH LINE TO APERTURE FACE:

1.0850" (27.5600MM)

CAUTION: Application Approval Required for PTO Output Shaft Speeds Above 2500 RPM

PTO Model	Torq I / C †	Dir Rot	Engine %		Filler Block	Adapter Assy	Stud Kit	PTO Model	Torq I / C †	Dir Rot	Engine %		Filler Block	Adapter Assy	Stud Kit
			Fwd	Rev							Fwd	Rev			

ONE SPEED - TWO GEAR POWERSHIFT (AIR OR HYDRAULIC)

282XCAJX-*3 (22)	250 C	Opp	83		8-A-032		Furnished	272XCAJX-*3 (32)	250 C	Opp	83				Furnished
282XDAJX-*3 (23)	250 C	Opp	100		8-A-032		Furnished	272XDAJX-*3 (33)	250 C	Opp	100				Furnished
282XGAJX-*3 (24)	250 C	Opp	118		8-A-032		Furnished	272XGAJX-*3 (34)	250 C	Opp	118				Furnished
282XKAJX-*3 (25)	250 C	Opp	132		8-A-032		Furnished	272XKAJX-*3 (35)	250 C	Opp	132				Furnished
282XMAJX-*3 (26)	250 C	Opp	148		8-A-032		Furnished	272XMAJX-*3 (36)	250 C	Opp	148				Furnished
282XPAJX-*3 (27)	250 C	Opp	165		8-A-032		Furnished	272XPAJX-*3 (37)	250 C	Opp	165				Furnished
282XSAJX-*3 (28)	225 C	Opp	185		8-A-032		Furnished	272XSAJX-*3 (38)	225 C	Opp	185				Furnished
282XTAJX-*3 (29)	225 C	Opp	207		8-A-032		Furnished								

ONE SPEED - POWERSHIFT LOW PROFILE (AIR OR HYDRAULIC)

272MAAJX-*3 (30)	250 C	Opp	56			328481X	Furnished	272MAAJX-*3 (30)	250 C	Opp	56				Furnished
								272MBAJX-*3 (31)	250 C	Opp	69				Furnished
								272MCAJX-*3 (32)	250 C	Opp	83				Furnished
								272MDAJX-*3 (33)	250 C	Opp	100				Furnished
								272MGAJX-*3 (34)	250 C	Opp	118				Furnished
								272MKAJX-*3 (35)	250 C	Opp	132				Furnished
								272MMAJX-*3 (36)	250 C	Opp	148				Furnished
								272MPAJX-*3 (37)	250 C	Opp	165				Furnished
								272MSAJX-*3 (38)	225 C	Opp	185				Furnished

ONE SPEED - TWO GEAR - POWERSHIFT (AIR)

885XBAHX-*3 (3)	500 I	Opp	69				Furnished								
85XGAHX-*3 (9)	500 I	Opp	89				Furnished								
885XJAHX-*3 (5)	500 I	Opp	104				Furnished								
885XMAHX-*3 (6)	500 I	Opp	122				Furnished								

ONE SPEED - FORWARD & REVERSE

348XFAHX-*5 (42)	200 I	Opp	88	93			Furnished	340XFAHX-*5 (42)	200 I	Opp	88	93	7-A-140(46)		Furnished
863XBAHX-*5	500 I	Opp	69	85			Furnished								

GEARED ADAPTERS

628XAHX-3AH	250 I	Eng					Furnished	626XAHX-3AH	250 I	Eng					Furnished
-------------	-------	-----	--	--	--	--	-----------	-------------	-------	-----	--	--	--	--	-----------

Continued on Next Page

† I = Intermittent Torque Only - De-rate Torque Rating 30% for Continuous Duty.

C = Continuous or Intermittent Torque - No need to De-Rate Torque Rating.

IMPORTANT: Refer to the back of this transmission section and read all notes associated with this application page. Some notes may affect the proper PTO selection.**CAUTION:** Do not use geared adapters with 442 A and C ratios.(3) Input Gear Part No. 5-P-1100
(5) Input Gear Part No. 5-P-1102
(6) Input Gear Part No. 5-P-1103
(9) Input Gear Part No. 5-P-1135
(22) Input Gear Part No. 5-P-1510-12X
(23) Input Gear Part No. 5-P-1510-13X(24) Input Gear Part No. 5-P-1510-14X
(25) Input Gear Part No. 5-P-1510-15X
(26) Input Gear Part No. 5-P-1510-16X
(27) Input Gear Part No. 5-P-1510-17X
(28) Input Gear Part No. 5-P-1510-18X
(29) Input Gear Part No. 5-P-1510-19X(30) Input Gear Part No. 5-P-1510-1X
(31) Input Gear Part No. 5-P-1510-2X
(32) Input Gear Part No. 5-P-1510-3X
(33) Input Gear Part No. 5-P-1510-4X
(34) Input Gear Part No. 5-P-1510-5X
(35) Input Gear Part No. 5-P-1510-6X(36) Input Gear Part No. 5-P-1510-7X
(37) Input Gear Part No. 5-P-1510-8X
(38) Input Gear Part No. 5-P-1510-9X
(42) Input Gear Part No. 5-P-581
(46) Filler block furnished with PTO

CHELSEA®

MERITOR/ROCKWELL

RKW-3

MO-11F9B-E11	MO-12G9B-D12	MO-13G9B-M13
MO-11F9B-S11	MO-12G9B-E12	MO-13G9B-S13
MO-11G9B-D11	MO-12G9B-M12	MO-14F9B-E14
MO-11G9B-E11	MO-12G9B-S12	MO-14F9B-S14
MO-11G9B-M11	MO-13F9B-E13	MO-14G9B-D14
MO-11G9B-S11	MO-13F9B-S13	MO-14G9B-E14
MO-12F9B-E12	MO-13G9B-D13	MO-14G9B-M14
MO-12F9B-S12	MO-13G9B-E13	MO-14G9B-S14

BOTTOM SIDE ONLY	RIGHT SIDE ONLY
TRANSMISSION GEAR DATA: BOT 08-BOLT Opening Gear FORWARD of Centerline 45 Teeth - SPUR PITCH LINE TO APERTURE FACE: 0.8100" (20.5740MM)	TRANSMISSION GEAR DATA: R.S. 06-BOLT Opening Gear FORWARD of Centerline 45 Teeth - SPUR PITCH LINE TO APERTURE FACE: 1.0850" (27.5600MM)

CAUTION: Application Approval Required for PTO Output Shaft Speeds Above 2500 RPM

PTO Model	Torq	Dir Rot	Engine %		Filler Block	Adapter Assy	Stud Kit	PTO Model	Torq	Dir Rot	Engine %		Filler Block	Adapter Assy	Stud Kit
	I / C †		Fwd	Rev					I / C †		Fwd	Rev			

GEARED ADAPTERS

630XAHX-3AH	250 I	Eng	Furnished
645XAHX-3AH	250 I	Eng	Furnished

† I = Intermittent Torque Only - De-rate Torque Rating 30% for Continuous Duty.

C = Continuous or Intermittent Torque - No need to De-Rate Torque Rating.

IMPORTANT: Refer to the back of this transmission section and read all notes associated with this application page. Some notes may affect the proper PTO selection.

CAUTION: Do not use geared adapters with 442 A and C ratios.

Meritor/Rockwell

RKW-4

MERITOR/ROCKWELL



MO-11F10C-E11	MO-12G10C-D12	MO-13G10C-M13
MO-11F10C-S11	MO-12G10C-E12	MO-13G10C-S13
MO-11G10C-D11	MO-12G10C-M12	MO-14F10C-E14
MO-11G10C-E11	MO-12G10C-S12	MO-14F10C-E16
MO-11G10C-M11	MO-13F10C-E13	MO-14F10C-M16
MO-11G10C-S11	MO-13F10C-S13	MO-14F10C-S14
MO-12F10C-E12	MO-13G10C-D13	MO-14F10C-S16
MO-12F10C-S12	MO-13G10C-E13	MO-14G10C-D14

BOTTOM SIDE ONLY	RIGHT SIDE ONLY
TRANSMISSION GEAR DATA: BOT 08-BOLT Opening Gear FORWARD of Centerline 45 Teeth - SPUR PITCH LINE TO APERTURE FACE: 0.8100" (20.5740MM)	TRANSMISSION GEAR DATA: R.S. 06-BOLT Opening Gear FORWARD of Centerline 45 Teeth - SPUR PITCH LINE TO APERTURE FACE: 1.0850" (27.5600MM)

CAUTION: Application Approval Required for PTO Output Shaft Speeds Above 2500 RPM

PTO Model	Torq I / C †	Dir Rot	Engine %		Filler Block	Adapter Assy	Stud Kit	PTO Model	Torq I / C †	Dir Rot	Engine %		Filler Block	Adapter Assy	Stud Kit
			Fwd	Rev							Fwd	Rev			

ONE SPEED - TWO GEAR - MECHANICAL SHIFT

221ZCAHX-*3	250 I	Opp	82		7-A-032(P)(39)	328564X	Furnished	221XCAHX-*3	250 I	Opp	82		7-A-032(P)(39)		Furnished
221ZEAHX-*3	250 I	Opp	95			328564X	Furnished	221XEAHX-*3	250 I	Opp	95				Furnished
489XAAHX-*5 (12)	250 I	Opp	72				Furnished	442XAAHX-*3 (12)	250 I	Opp	72				Furnished
489XCAHX-*5 (13)	250 I	Opp	92				Furnished	442XBAHX-*3 (18)	250 I	Eng	72			REQUIRED	Furnished
489XFAHX-*5 (2)	250 I	Opp	114				Furnished	442XCAHX-*3 (13)	250 I	Opp	92				Furnished
489XHAHX-*5 (15)	250 I	Opp	132				Furnished	442XFAHX-*3 (2)	250 I	Opp	114				Furnished
489XLAHX-*5 (1)	250 I	Opp	148				Furnished	442XHAHX-*3 (15)	250 I	Opp	132				Furnished
489XQAHX-*5 (1)	225 I	Opp	159				Furnished	442XLAHX-*3 (1)	250 I	Opp	148				Furnished
489XRAHX-*5 (1)	225 I	Opp	184				Furnished	442XQAHX-*3 (1)	225 I	Opp	159				Furnished
489XSAHX-*5 (1)	200 I	Opp	219				Furnished	442XRAHX-*3 (1)	225 I	Opp	184				Furnished
489XUAHX-*5 (1)	195 I	Opp	261				Furnished	442XSAHX-*3 (1)	200 I	Opp	219				Furnished
489XWAHX-*5 (1)	175 I	Opp	307				Furnished	442XUAHX-*3 (1)	195 I	Opp	261				Furnished
489XXAHX-*5 (1)	140 I	Opp	363				Furnished	442XWAHX-*3 (1)	175 I	Opp	307				Furnished
680XFAHX-*3 (10)	375 I	Opp	114				Furnished	442XXAHX-*3 (1)	140 I	Opp	363				Furnished
680XHAHX-*3 (20)	375 I	Opp	132				Furnished	660XFAHX-*3 (10)	375 I	Opp	114				Furnished
680XQAHX-*3 (11)	375 I	Opp	159				Furnished	660XHAHX-*3 (15)	375 I	Opp	132				Furnished
680XRAHX-*3 (19)	350 I	Opp	184				Furnished	660XQAHX-*3 (11)	375 I	Opp	159				Furnished
680XSAHX-*3 (14)	325 I	Opp	219				Furnished	660XRAHX-*3 (19)	350 I	Opp	184				Furnished
823XTKTX-*3 (17)	350 I	Opp	230		8-A-165(39)		Furnished	660XSAHX-*3 (14)	325 I	Opp	219				Furnished
880XBAHX-*3 (3)	500 I	Opp	78				Furnished								
880XDAHX-*3 (4)	500 I	Opp	92				Furnished								
880XGAHX-*3 (9)	500 I	Opp	100				Furnished								
880XJAHX-*3 (5)	500 I	Opp	118				Furnished								
880XMAHX-*3 (6)	500 I	Opp	138				Furnished								
880XQAHX-*3 (16)	450 I	Opp	162				Furnished								
880XRAHX-*3 (7)	400 I	Opp	191				Furnished								
880XTAHX-*3 (8)	350 I	Opp	245				Furnished								

ONE SPEED - TWO GEAR POWERSHIFT (AIR OR HYDRAULIC)

272XAAJX-*3 (29)	250 C	Opp	63			328481X	Furnished	272XAAJX-*3 (29)	250 C	Opp	63				Furnished
282XBAJX-*3 (21)	250 C	Opp	78		8-A-032		Furnished	272XBAJX-*3 (30)	250 C	Opp	78				Furnished
282XCAJX-*3 (22)	250 C	Opp	94		8-A-032		Furnished	272XCAJX-*3 (31)	250 C	Opp	94				Furnished

Continued on Next Page

† I = Intermittent Torque Only - De-rate Torque Rating 30% for Continuous Duty. C = Continuous or Intermittent Torque - No need to De-Rate Torque Rating.

IMPORTANT: Refer to the back of this transmission section and read all notes associated with this application page. Some notes may affect the proper PTO selection.

CAUTION: Do not use geared adapters with 442 A and C ratios.

- | | | | | |
|----------------------------------|-----------------------------------|-----------------------------------|---------------------------------------|--------------------------------------|
| (1) Input Gear Part No. 5-P-1004 | (7) Input Gear Part No. 5-P-1104 | (13) Input Gear Part No. 5-P-1287 | (19) Input Gear Part No. 5-P-1441 | (31) Input Gear Part No. 5-P-1510-3X |
| (2) Input Gear Part No. 5-P-1077 | (8) Input Gear Part No. 5-P-1105 | (14) Input Gear Part No. 5-P-1322 | (20) Input Gear Part No. 5-P-1494 | (39) Filler block furnished with PTO |
| (3) Input Gear Part No. 5-P-1100 | (9) Input Gear Part No. 5-P-1135 | (15) Input Gear Part No. 5-P-1364 | (21) Input Gear Part No. 5-P-1510-11X | |
| (4) Input Gear Part No. 5-P-1101 | (10) Input Gear Part No. 5-P-1242 | (16) Input Gear Part No. 5-P-1385 | (22) Input Gear Part No. 5-P-1510-12X | |
| (5) Input Gear Part No. 5-P-1102 | (11) Input Gear Part No. 5-P-1246 | (17) Input Gear Part No. 5-P-1395 | (29) Input Gear Part No. 5-P-1510-1X | |
| (6) Input Gear Part No. 5-P-1103 | (12) Input Gear Part No. 5-P-1280 | (18) Input Gear Part No. 5-P-1418 | (30) Input Gear Part No. 5-P-1510-2X | |



October 2022
5.12.20

Parker Hannifin Corporation
Chelsea Products Division
Olive Branch, MS 38654 USA

CHELSEA®

MERITOR/ROCKWELL

RKW-4

MO-11F10C-E11 MO-11F10C-S11 MO-11G10C-D11 MO-11G10C-E11 MO-11G10C-M11 MO-11G10C-S11 MO-12F10C-E12 MO-12F10C-S12	MO-12G10C-D12 MO-12G10C-E12 MO-12G10C-M12 MO-12G10C-S12 MO-13F10C-E13 MO-13F10C-S13 MO-13G10C-D13 MO-13G10C-E13	MO-13G10C-M13 MO-13G10C-S13 MO-14F10C-E14 MO-14F10C-E16 MO-14F10C-M16 MO-14F10C-S14 MO-14F10C-S16 MO-14G10C-D14
--	--	--

BOTTOM SIDE ONLY	RIGHT SIDE ONLY
-------------------------	------------------------

TRANSMISSION GEAR DATA: BOT 08-BOLT Opening Gear FORWARD of Centerline 45 Teeth - SPUR PITCH LINE TO APERTURE FACE: 0.8100" (20.5740MM)	TRANSMISSION GEAR DATA: R.S. 06-BOLT Opening Gear FORWARD of Centerline 45 Teeth - SPUR PITCH LINE TO APERTURE FACE: 1.0850" (27.5600MM)
---	--

CAUTION: Application Approval Required for PTO Output Shaft Speeds Above 2500 RPM

PTO Model	Torq I / C †	Dir Rot	Engine %		Filler Block	Adapter Assy	Stud Kit	PTO Model	Torq I / C †	Dir Rot	Engine %		Filler Block	Adapter Assy	Stud Kit
			Fwd	Rev							Fwd	Rev			

ONE SPEED - TWO GEAR POWERSHIFT (AIR OR HYDRAULIC)

282XDAJX-*3 (23)	250 C	Opp	112		8-A-032		Furnished	272XDAJX-*3 (32)	250 C	Opp	112				Furnished
282XGAJX-*3 (24)	250 C	Opp	134		8-A-032		Furnished	272XGAJX-*3 (33)	250 C	Opp	134				Furnished
282XKAJX-*3 (25)	250 C	Opp	149		8-A-032		Furnished	272XKAJX-*3 (34)	250 C	Opp	149				Furnished
282XMAJX-*3 (26)	250 C	Opp	167		8-A-032		Furnished	272XMAJX-*3 (35)	250 C	Opp	167				Furnished
282XPAJX-*3 (27)	250 C	Opp	187		8-A-032		Furnished	272XPAJX-*3 (36)	250 C	Opp	187				Furnished
282XSAJX-*3 (28)	225 C	Opp	209		8-A-032		Furnished	272XSAJX-*3 (37)	225 C	Opp	209				Furnished

ONE SPEED - POWERSHIFT LOW PROFILE (AIR OR HYDRAULIC)

272MAAJX-*3 (29)	250 C	Opp	63			328481X	Furnished	272MAAJX-*3 (29)	250 C	Opp	63				Furnished
								272MBAJX-*3 (30)	250 C	Opp	78				Furnished
								272MCAJX-*3 (31)	250 C	Opp	94				Furnished
								272MDAJX-*3 (32)	250 C	Opp	112				Furnished
								272MGAJX-*3 (33)	250 C	Opp	134				Furnished
								272MKAJX-*3 (34)	250 C	Opp	149				Furnished
								272MMAJX-*3 (35)	250 C	Opp	167				Furnished
								272MPAJX-*3 (36)	250 C	Opp	187				Furnished
								272MSAJX-*3 (37)	225 C	Opp	209				Furnished

ONE SPEED - TWO GEAR - POWERSHIFT (AIR)

885XBAHX-*3 (3)	500 I	Opp	78				Furnished								
885XGAHX-*3 (9)	500 I	Opp	100				Furnished								
885XJAHX-*3 (5)	500 I	Opp	118				Furnished								
885XMAHX-*3 (6)	500 I	Opp	138				Furnished								

ONE SPEED - FORWARD & REVERSE

348XFAHX-*5 (38)	200 I	Opp	100	105			Furnished	340XFAHX-*5 (38)	200 I	Opp	100	105	7-A-140(39)		Furnished
863XBAHX-*5	500 I	Opp	78	96			Furnished								

GEARED ADAPTERS

628XAHX-3AH	250 I	Eng					Furnished	626XAHX-3AH	250 I	Eng					Furnished
								630XAHX-3AH	250 I	Eng					Furnished
								645XAHX-3AH	250 I	Eng					Furnished

† I = Intermittent Torque Only - De-rate Torque Rating 30% for Continuous Duty. C = Continuous or Intermittent Torque - No need to De-Rate Torque Rating.

IMPORTANT: Refer to the back of this transmission section and read all notes associated with this application page. Some notes may affect the proper PTO selection.

CAUTION: Do not use geared adapters with 442 A and C ratios.

- | | | | |
|---------------------------------------|---------------------------------------|--------------------------------------|--------------------------------------|
| (3) Input Gear Part No. 5-P-1100 | (25) Input Gear Part No. 5-P-1510-15X | (31) Input Gear Part No. 5-P-1510-3X | (37) Input Gear Part No. 5-P-1510-9X |
| (5) Input Gear Part No. 5-P-1102 | (26) Input Gear Part No. 5-P-1510-16X | (32) Input Gear Part No. 5-P-1510-4X | (38) Input Gear Part No. 5-P-581 |
| (6) Input Gear Part No. 5-P-1103 | (27) Input Gear Part No. 5-P-1510-17X | (33) Input Gear Part No. 5-P-1510-5X | (39) Filler block furnished with PTO |
| (9) Input Gear Part No. 5-P-1135 | (28) Input Gear Part No. 5-P-1510-18X | (34) Input Gear Part No. 5-P-1510-6X | |
| (23) Input Gear Part No. 5-P-1510-13X | (29) Input Gear Part No. 5-P-1510-1X | (35) Input Gear Part No. 5-P-1510-7X | |
| (24) Input Gear Part No. 5-P-1510-14X | (30) Input Gear Part No. 5-P-1510-2X | (36) Input Gear Part No. 5-P-1510-8X | |

ZFM-5

MERITOR/ROCKWELL

CHELSEA®

M-13Z12A-A14 (Rear Mount PTO)
M-13Z12A-A13 (Rear Mount PTO)
M-14Z12A-A14 (Rear Mount PTO)

REAR SIDE ONLY

TRANSMISSION GEAR DATA:

REAR 04-BOLT Opening Gear NON-STANDARD of Centerline

PITCH LINE TO APERTURE FACE:

CAUTION: Application Approval Required for PTO Output Shaft Speeds Above 2500 RPM

PTO Model	Torq	Dir Rot	Engine %		Filler Block	Adapter Assy	Stud Kit	PTO Model	Torq	Dir Rot	Engine %		Filler Block	Adapter Assy	Stud Kit
	I / C †		Fwd	Rev					I / C †		Fwd	Rev			

REAR MOUNT - MECHANICAL SHIFT (12 SPEED TRANSMISSIONS)

524XMACX-F-*	300 C	Eng	84				Furnished
524XTACX-F-*	300 C	Eng	109				Furnished
524XVACX-F-*	258 C	Eng	148				Furnished

† I = Intermittent Torque Only - De-rate Torque Rating 30% for Continuous Duty.

C = Continuous or Intermittent Torque - No need to De-Rate Torque Rating.

IMPORTANT: Refer to the back of this transmission section and read all notes associated with this application page. Some notes may affect the proper PTO selection.

WARNING: Any attempt to bypass transmission control may result in damage to Freedomline Transmissions.

CAUTION: PTO installers must ensure that PTOs are integrated in a manner that permits proper transmission control of PTO engagement and disengagement.

CHELSEA®

MERITOR/ROCKWELL

ZFM-6

MO-14Z12A-A16 (Rear Mount PTO)
 MO-15Z12A-A16 (Rear Mount PTO)
 MO-14Z12A-A14 (Rear Mount PTO)
 MO-13Z12A-A13 (Rear Mount PTO)
 MO-15Z12A-A15 (Rear Mount PTO)
 MO-16Z12A-A16 (Rear Mount PTO)
 MO-13Z12A-A14 (Rear Mount PTO)

REAR SIDE ONLY**TRANSMISSION GEAR DATA:**

REAR 04-BOLT Opening Gear NON-STANDARD of Centerline

PITCH LINE TO APERTURE FACE:**CAUTION: Application Approval Required for PTO Output Shaft Speeds Above 2500 RPM**

PTO Model	Torq I / C †	Dir Rot	Engine %		Filler Block	Adapter Assy	Stud Kit	PTO Model	Torq I / C †	Dir Rot	Engine %		Filler Block	Adapter Assy	Stud Kit
			Fwd	Rev							Fwd	Rev			

REAR MOUNT - MECHANICAL SHIFT (12 SPEED TRANSMISSIONS)

524XMACX-F-*	300 C	Eng	139				Furnished
524XTACX-F-*	258 C	Eng	180				Furnished
524XVACX-F-*	258 C	Eng	243				Furnished

† I = Intermittent Torque Only - De-rate Torque Rating 30% for Continuous Duty.

C = Continuous or Intermittent Torque - No need to De-Rate Torque Rating.

IMPORTANT: Refer to the back of this transmission section and read all notes associated with this application page.
 Some notes may affect the proper PTO selection.

WARNING: Any attempt to bypass transmission control may result in damage to Freedomline Transmissions.

CAUTION: PTO installers must ensure that PTOs are integrated in a manner that permits proper transmission control of PTO engagement and disengagement.

Meritor/Rockwell

ZFM-7

MERITOR/ROCKWELL

CHELSEA®

MO-15Z16A-A15 (Rear Mount PTO)
MO-15Z16A-A16 (Rear Mount PTO)
MO-13Z16A-A13 (Rear Mount PTO)
MO-14Z16A-A14 (Rear Mount PTO)
MO-16Z16A-A16 (Rear Mount PTO)
MO-13Z16A-A14 (Rear Mount PTO)
MO-14Z16A-A16 (Rear Mount PTO)

REAR SIDE ONLY

TRANSMISSION GEAR DATA:

REAR 04-BOLT Opening Gear NON-STANDARD of Centerline

PITCH LINE TO APERTURE FACE:

CAUTION: Application Approval Required for PTO Output Shaft Speeds Above 2500 RPM

PTO Model	Torq	Dir Rot	Engine %		Filler Block	Adapter Assy	Stud Kit	PTO Model	Torq	Dir Rot	Engine %		Filler Block	Adapter Assy	Stud Kit
	I / C †		Fwd	Rev					I / C †		Fwd	Rev			

REAR MOUNT - MECHANICAL SHIFT (16 SPEED TRANSMISSIONS)

524XMACX-F-*	300 C	Eng	114				Furnished
524XTACX-F-*	300 C	Eng	148				Furnished
524XVACX-F-*	258 C	Eng	200				Furnished

† I = Intermittent Torque Only - De-rate Torque Rating 30% for Continuous Duty.

C = Continuous or Intermittent Torque - No need to De-Rate Torque Rating.

IMPORTANT: Refer to the back of this transmission section and read all notes associated with this application page. Some notes may affect the proper PTO selection.

WARNING: Any attempt to bypass transmission control may result in damage to Freedomline Transmissions.

CAUTION: PTO installers must ensure that PTOs are integrated in a manner that permits proper transmission control of PTO engagement and disengagement.

Meritor/Rockwell Notes

RKW-1

1. The AK & XK output flanges can not be used with the A & C ratios on the 489 Series PTOs due to mounting stud interference. Use a RA or RB rotatable flange for the XK and the RA for the AK flange.
 2. Two Gear PTOs with Direct Mount Pumps may Not Clear the Transmission Bulge on the Right Side. Check for Clearance Before Mounting the PTO and Pump.
 3. The 422XBAH MUST be used with one of the Geared Adapters Listed on the Application Page. Direction of rotation shown is the final output shaft rotation w/ Geared Adapter.
 4. 272/282 Series-Must be used as an AIR Shift PTO. Order Air Shift Options Only
-

RKW-2

1. The AK & XK output flanges can not be used with the A & C ratios on the 489 Series PTOs due to mounting stud interference. Use a RA or RB rotatable flange for the XK and the RA for the AK flange.
 2. Two Gear PTOs with Direct Mount Pumps may Not Clear the Transmission Bulge on the Right Side. Check for Clearance Before Mounting the PTO and Pump.
 3. The 422XBAH MUST be used with one of the Geared Adapters Listed on the Application Page. Direction of rotation shown is the final output shaft rotation w/ Geared Adapter.
 4. 272/282 Series-Must be used as an AIR Shift PTO. Order Air Shift Options Only
-

RKW-3

1. Use constant mesh PTOs only on this application.
 2. The AK & XK output flanges can not be used with the A & C ratios on the 489 Series PTOs due to mounting stud interference. Use a RA or RB rotatable flange for the XK and the RA for the AK flange.
 3. Two gear PTOs with direct mount pumps may not clear the transmission bulge on the right side. Check for clearance before mounting the PTO and pump.
 4. The 422XBAH MUST be used with one of the Geared Adapters Listed on the Application Page. Direction of rotation shown is the final output shaft rotation w/ Geared Adapter.
 5. 272/282 Series-Must be used as an AIR Shift PTO. Order Air Shift Options Only
-

RKW-4

1. The AK & XK output flanges can not be used with the A & C ratios on the 489 Series PTOs due to mounting stud interference. Use a RA or RB rotatable flange for the XK and the RA for the AK flange.
 2. The 422XBAH MUST be used with one of the Geared Adapters Listed on the Application Page. Direction of rotation shown is the final output shaft rotation w/ Geared Adapter.
 3. 272/282 Series-Must be used as an AIR Shift PTO. Order Air Shift Options Only
-

ZFM-5

1. Freedomline Transmissions must control PTO engagement. The F shift option provides a ZF Meritor approved 12V / Air Shift Kit and wiring harness to connect to the transmission (ZMTEC) controller.
 2. Use installation kit 328388-82X (12V / Air w/ wiring harness) to connect a 524 Series, or contact ZF Meritor (800-535-5560) for other wiring considerations or ZMTEC software questions.
 3. 524 Rear Mount - Adapter Assembly 329993X is furnished with the PTO and does not need to be ordered separately.
-

ZFM-6

1. Freedomline Transmissions must control PTO engagement. The F shift option provides a ZF Meritor approved 12V / Air Shift Kit and wiring harness to connect to the transmission (ZMTEC) controller.
2. Use installation kit 328388-82X (12V / Air w/ wiring harness) to connect a 524 Series, or contact ZF Meritor (800-535-5560) for other wiring considerations or ZMTEC software questions.
3. 524 Rear Mount - Adapter Assembly 329993X is furnished with the PTO and does not need to be ordered separately.

Meritor/Rockwell Notes

ZFM-7

1. Freedomline Transmissions must control PTO engagement. The F shift option provides a ZF Meritor approved 12V / Air Shift Kit and wiring harness to connect to the transmission (ZMTEC) controller.
2. Use installation kit 328388-82X (12V / Air w/ wiring harness) to connect a 524 Series, or contact ZF Meritor (800-535-5560) for other wiring considerations or ZMTEC software questions.
3. 524 Rear Mount - Adapter Assembly 329993X is furnished with the PTO and does not need to be ordered separately.

PACCGAR



Parker | Chelsea

ENGINEERING YOUR SUCCESS.

**WARNING — User Responsibility**

FAILURE OR IMPROPER SELECTION OR IMPROPER USE OF THE PRODUCTS DESCRIBED HEREIN OR RELATED ITEMS CAN CAUSE DEATH, PERSONAL INJURY AND PROPERTY DAMAGE.

This document and other information from Parker Hannifin Corporation, its subsidiaries and authorized distributors provide product or system options for further investigation by users having technical expertise.

The user, through its own analysis and testing, is solely responsible for making the final selection of the system and components and assuring that all performance, endurance, maintenance, safety and warning requirements of the application are met. The user must analyze all aspects of the application, follow applicable industry standards, and follow the information concerning the product in the current product catalog and in any other materials provided from Parker or its subsidiaries or authorized distributors.

To the extent that Parker or its subsidiaries or authorized distributors provide component or system options based upon data or specifications provided by the user, the user is responsible for determining that such data and specifications are suitable and sufficient for all applications and reasonably foreseeable uses of the components or systems.

Offer of Sale

The items described in this document are hereby offered for sale by Parker Hannifin Corporation, its subsidiaries or its authorized distributors. This offer and its acceptance are governed by the provisions stated in the "Offer of Sale".



WARNING: This product can expose you to chemicals including Lead and Lead Compounds, and Di(2-ethylhexyl)phthalate (DEHP) which are known to the State of California to cause cancer and birth defects or other reproductive harm. For more information go to www.P65Warnings.ca.gov

© Copyright 2022, Parker Hannifin Corporation, All Rights Reserved

Transmission Make and Model	PTO Appl. Number	Number Forward Speeds	Teeth in PTO Driver
TX-8 (Paccar)	PAC-2	8	L51-R51
TX-12 PO-14F112C (Eaton EEO-14F112C)	PAC-1	12	CS-B42
TX-12 PO-15F112C (Eaton EEO-15F112C)	PAC-1	12	CS-B42
TX-12 PO-16F112C (Eaton EEO-16F112C)	PAC-1	12	CS-B42
TX-12 PO-17F112C (Eaton EEO-17F112C)	PAC-1	12	CS-B42
TX-12 PO-18F112C (Eaton EEO-18F112C)	PAC-1	12	CS-B42
TX-18 PXD-16F118D	PAC-3	18	CS-B46
TX-18 PXD-18F118D	PAC-3	18	CS-B46
TX-18 PRO PXDP-16F118D	PAC-3	18	CS-B46
TX-18 PRO PXDP-18F118D	PAC-3	18	CS-B46



IMPORTANT: See Safety Information in Section 1 of the Chelsea Applications catalog HY25-3000/US

Transmission PTO Driver & Apertures (Viewed from Rear of Transmission)
L-Left Side R-Right Side B-Bottom Side T-Top Side CS-Countershaft
For transmissions not listed, contact your authorized Chelsea Distributor.

PAC-1

PACCAR

CHELSEA®

TX-12 PO-14F112C (Eaton EEO-14F112C)
TX-12 PO-15F112C (Eaton EEO-15F112C)
TX-12 PO-16F112C (Eaton EEO-16F112C)
TX-12 PO-17F112C (Eaton EEO-17F112C)
TX-12 PO-18F112C (Eaton EEO-18F112C)

BOTTOM SIDE ONLY

REAR SIDE ONLY

TRANSMISSION GEAR DATA:

BOT 08-BOLT Opening Gear FORWARD of Centerline
46 Teeth - SPUR HELIX

PITCH LINE TO APERTURE FACE:

0.820" (20.8204MM)

TRANSMISSION GEAR DATA:

REAR 04-BOLT Opening Gear NON-STANDARD of Centerline
Teeth - SPUR

PITCH LINE TO APERTURE FACE:

0" (0MM)

CAUTION: Application Approval Required for PTO Output Shaft Speeds Above 2500 RPM

PTO Model	Torq	Dir Rot	Engine %		Filler Block	Adapter Assy	Stud Kit	PTO Model	Torq	Dir Rot	Engine %		Filler Block	Adapter Assy	Stud Kit
	I / C †		Fwd	Rev					I / C †		Fwd	Rev			

ONE SPEED - TWO GEAR - MECHANICAL SHIFT

489QCLZX-*3 (5)	200 I	Opp	94				Furnished
489QFLZX-*3 (6)	250 I	Opp	116				Furnished
489QHLZX-*3 (7)	250 I	Opp	135				Furnished
489QLLZX-*3 (1)	225 I	Opp	151				Furnished
489QQLZX-*3 (1)	225 I	Opp	162				Furnished
489QRLZX-*3 (1)	225 I	Opp	188				Furnished
680QFLZX-*3 (8)	375 I	Opp	116				Furnished
680QHLZX-*3 (9)	375 I	Opp	135				Furnished
680QRLZX-*3 (10)	350 I	Opp	188				Furnished
880QGLZX-*3 (2)	500 I	Opp	107				Furnished
880QJLZX-*3 (3)	500 I	Opp	125				Furnished
880QQLZX-*3 (4)	450 I	Opp	173				Furnished

REAR MOUNT - MECHANICAL SHIFT

511XRLZW-**	500 C	Opp	137				Furnished
524XMLZX-**	300 C	Eng	142				Furnished

† I = Intermittent Torque Only - De-rate Torque Rating 30% for Continuous Duty.

C = Continuous or Intermittent Torque - No need to De-Rate Torque Rating.

IMPORTANT: Refer to the back of this transmission section and read all notes associated with this application page. Some notes may affect the proper PTO selection.

WARNING: SHIFT OPTIONS - Only one shift option is available for this transmission, D 12V Elec/Air. PTO is required to interface with the TCM to signal operation. The necessary 12VDC wiring harness is provided with PTO.

CAUTION: The Transmission Control Module (TCM) must be configured for PTO operation using chassis software. The default setting for this feature is 'Disabled'. Failure to configure the TCM for PTO operation may result in transmission, PTO, or driven equipment damage. See PACCAR for additional information regarding this and dual (bottom + rear mount) PTO configuration.

- | | |
|----------------------------------|-----------------------------------|
| (1) Input Gear Part No. 5-P-1571 | (6) Input Gear Part No. 5-P-1588 |
| (2) Input Gear Part No. 5-P-1574 | (7) Input Gear Part No. 5-P-1589 |
| (3) Input Gear Part No. 5-P-1575 | (8) Input Gear Part No. 5-P-1590 |
| (4) Input Gear Part No. 5-P-1577 | (9) Input Gear Part No. 5-P-1591 |
| (5) Input Gear Part No. 5-P-1587 | (10) Input Gear Part No. 5-P-1593 |

CHELSEA®

PACCAR

PAC-2

TX-8 (Paccar)

LEFT SIDE ONLY**TRANSMISSION GEAR DATA:**L.S. 08-BOLT Opening Gear FORWARD of Centerline
51 Teeth - L.H. Helix**PITCH LINE TO APERTURE FACE:**

3.9777" (101.0336MM)

CAUTION: Application Approval Required for PTO Output Shaft Speeds Above 2500 RPM

PTO Model	Torq	Dir Rot	Engine %		Filler Block	Adapter Assy	Stud Kit	PTO Model	Torq	Dir Rot	Engine %		Filler Block	Adapter Assy	Stud Kit
	I / C †		Fwd	Rev					I / C †		Fwd	Rev			

ONE SPEED - TWO GEAR - MECHANICAL SHIFT

272UCMGP-*3 (1)	258 C	Opp	73				Furnished
272UDMGP-*3 (2)	258 C	Opp	88				Furnished
272UGMGP-*3 (3)	258 C	Opp	104				Furnished
272UKMGP-*3 (4)	258 C	Opp	117				Furnished
272UMMGP-*3 (5)	258 C	Opp	130				Furnished
272UPMGP-*3 (6)	253 C	Opp	146				Furnished

† I = Intermittent Torque Only - De-rate Torque Rating 30% for Continuous Duty.

C = Continuous or Intermittent Torque - No need to De-Rate Torque Rating.

IMPORTANT: Refer to the back of this transmission section and read all notes associated with this application page. Some notes may affect the proper PTO selection.

WARNING: SHIFT OPTIONS - Only one shift option is available for this transmission, D 12V Elec/Air. PTO is required to interface with the TCM to signal operation. The necessary 12VDC wiring harness is provided with PTO.

CAUTION: The Transmission Control Module (TCM) must be configured for PTO operation using chassis software. The default setting for this feature is 'Disabled'. Failure to configure the TCM for PTO operation may result in transmission, PTO, or driven equipment damage. See PACCAR for additional information regarding this and dual (bottom + rear mount) PTO configuration.

(1) Input Gear Part No. 5-P-1495
(2) Input Gear Part No. 5-P-1479
(3) Input Gear Part No. 5-P-1480
(4) Input Gear Part No. 5-P-1481
(5) Input Gear Part No. 5-P-1482

(6) Input Gear Part No. 5-P-1571

PAC-3

PACCAR

CHELSEA®

TX-18 PXD-16F118D
TX-18 PXD-16F118D
TX-18 PRO PXDP-16F118D
TX-18 PRO PXDP-16F118D

BOTTOM SIDE ONLY

REAR SIDE ONLY

TRANSMISSION GEAR DATA:

BOT 08-BOLT Opening Gear REAR of Centerline
46 Teeth - Spur

PITCH LINE TO APERTURE FACE:

.8197" (20.8204MM)

TRANSMISSION GEAR DATA:

Rear 4-Bolt Opening Gear NON STANDARD of Centerline
35 Teeth - Spur

PITCH LINE TO APERTURE FACE:

0" (0MM)

CAUTION: Application Approval Required for PTO Output Shaft Speeds Above 2500 RPM

PTO Model	Torq	Dir Rot	Engine %		Filler Block	Adapter Assy	Stud Kit	PTO Model	Torq	Dir Rot	Engine %		Filler Block	Adapter Assy	Stud Kit
	I / C †		Fwd	Rev					I / C †		Fwd	Rev			

ONE SPEED - TWO GEAR - MECHANICAL SHIFT

489QAMEX-*6(5)	225I	Opp	70		380711X		Furnished
489QFMEX-*6(1)	225I	Opp	111		380711X		Furnished
489QLMEX-*6(6)	225I	Opp	144		380711X		Furnished
489QQMEX-*6(6)	225I	Opp	155		380711X		Furnished
489QRMEX-*6(6)	225I	Opp	180		380711X		Furnished
680QFMEX-*6(7)	375I	Opp	111		380711X		Furnished
680QHME X-*6(8)	375I	Opp	129		380711X		Furnished
680QQMEX-*6(9)	375I	Opp	155		380711X		Furnished
880QGMEX-*4(2)	500I	Opp	112				Furnished
880QMMEX-*4(3)	395I	Opp	155				Furnished
880QQMEX-*4(4)	336I	Opp	181				Furnished

REAR MOUNT - MECHANICAL SHIFT

524XMMEX-**	300C	Eng	111				Furnished
524XTMEX-**	300C	Eng	150				Furnished
524XVMEX-**	258C	Eng	200				Furnished

† I = Intermittent Torque Only - De-rate Torque Rating 30% for Continuous Duty.

C = Continuous or Intermittent Torque - No need to De-Rate Torque Rating.

IMPORTANT: Refer to the back of this transmission section and read all notes associated with this application page. Some notes may affect the proper PTO selection.

CAUTION: For the 489 and 680 Series, the only shift options available are the 5 and 6 shift options. For the 880 Series, the only shift options available are the D and V shift options. All shift options are the 12V Elec/Air type. This shift type is required to interface with the transmission TCM. The necessary 12V wiring harness is provided with the 6 and D shift options.

CAUTION: The Endurant Transmission Control Module (TCM) must be configured for PTO operation using ServiceRanger software. The default setting for this feature is 'Disabled'. Failure to configure the TCM for PTO operation may result in transmission, PTO, or driven equipment damage. See Eaton PTO Information Guide TRIG2600 EN-US for additional information regarding this and dual (bottom + rear mount) PTO configuration.

CAUTION: 489 and 680 Series PTO's require the use of 380711X spacer plate for mounting to the transmission. The spacer plate is assembled between the PTO and transmission. See SK-672 for details. The spacer plate is included with the PTO. It does not need to be ordered separately.

CAUTION: Eaton Transmission Division has established a maximum torque limit for the transmission driver gear. For all Endurant XD transmissions the torque limit is as follows: 8-Bolt Bottom Mount - 555 lb-ft [745 Nm] continuous, Rear Mount - 555 lb-ft [745 Nm] continuous, Combined - 555 lb-ft [745 Nm] continuous.

CAUTION: 524 Series - External lubrication is required for this application. Lubrication kit 330085X is furnished with the PTO. Failure to install the lubrication kit prior to PTO start up may cause damage to the PTO and/or transmission. See SK-677 for details

(1) Input Gear Part No. 5-P-1688	(6) Input Gear Part No. 5-P-1703
(2) Input Gear Part No. 5-P-1670	(7) Input Gear Part No. 5-P-1705
(3) Input Gear Part No. 5-P-1671	(8) Input Gear Part No. 5-P-1706
(4) Input Gear Part No. 5-P-1672	(9) Input Gear Part No. 5-P-1707
(5) Input Gear Part No. 5-P-1702	

Paccar Notes

PAC-1

1. Gaskets are replaced by a custom molded o-ring. No backlash setting required. Special piloting studs are included in lieu of dowel pins.

PAC-2

1. Gaskets are replaced by a custom molded o-ring. No backlash setting required. Special piloting studs are included in lieu of dowel pins.

PAC-3

1. Gaskets are replaced by a custom molded o-ring. No backlash setting required. Special piloting studs are included in lieu of dowel pins.
2. The D or 6 shift option must be used for new installations. A 4-way valve will be provided with these shift options that supplies air to both sides of the shifter. The factory air valve cannot be used because it is only a 3-way valve. The V or 5 shift option can be used for replacement PTO's.
3. The AK & XK output flanges can not be used with the A & C ratios on the 489 Series PTOs due to mounting stud interference. Use the RK rotatable flange for the A & C ratios.
4. 524 Series - The Input Adapter 330086X is furnished with the PTO
5. The Endurant transmission is equipped with threaded support bosses on the back of the transmission for pump support brackets. See Eaton PTO Information Guide TRIG2600 EN-US for additional information and support locations.



TREMEC/TTC/SPICER

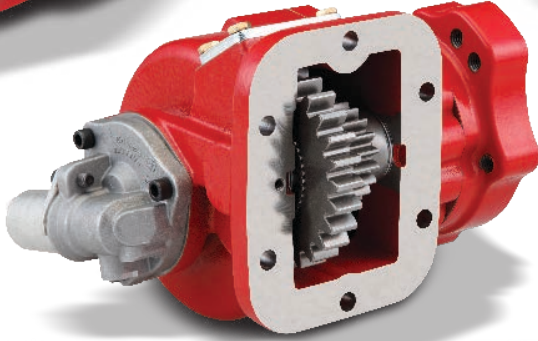
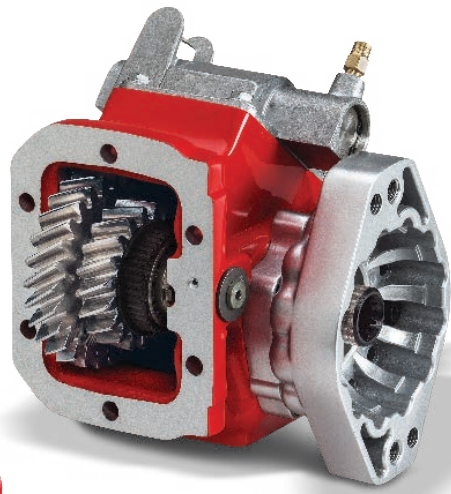

Parker | Chelsea

ENGINEERING YOUR SUCCESS.



WARNING — User Responsibility

FAILURE OR IMPROPER SELECTION OR IMPROPER USE OF THE PRODUCTS DESCRIBED HEREIN OR RELATED ITEMS CAN CAUSE DEATH, PERSONAL INJURY AND PROPERTY DAMAGE.

This document and other information from Parker Hannifin Corporation, its subsidiaries and authorized distributors provide product or system options for further investigation by users having technical expertise.

The user, through its own analysis and testing, is solely responsible for making the final selection of the system and components and assuring that all performance, endurance, maintenance, safety and warning requirements of the application are met. The user must analyze all aspects of the application, follow applicable industry standards, and follow the information concerning the product in the current product catalog and in any other materials provided from Parker or its subsidiaries or authorized distributors.

To the extent that Parker or its subsidiaries or authorized distributors provide component or system options based upon data or specifications provided by the user, the user is responsible for determining that such data and specifications are suitable and sufficient for all applications and reasonably foreseeable uses of the components or systems.

Offer of Sale

The items described in this document are hereby offered for sale by Parker Hannifin Corporation, its subsidiaries or its authorized distributors. This offer and its acceptance are governed by the provisions stated in the "Offer of Sale".



WARNING: This product can expose you to chemicals including Lead and Lead Compounds, and Di(2-ethylhexyl)phthalate (DEHP) which are known to the State of California to cause cancer and birth defects or other reproductive harm. For more information go to www.P65Warnings.ca.gov

© Copyright 2022, Parker Hannifin Corporation, All Rights Reserved

TREMEC/TTC/SPICER TRANSMISSION INDEX

Transmission Make and Model	PTO Appl. Number	Number Forward Speeds	Teeth in PTO Driver
1010-3B (BM#301115 and Later)	SPR-105	10	R48-B48
1020-3A (BM#301125 and Later)	SPR-105	20	R48-B48
1020-5A (BM#301126 and Later)	SPR-105	20	R48-B48
1214-3A (BM#301212 & 301130 and Later)	SPR-104	14	R54-B54
1214-5A (BM#301213 & 301131 and Later)	SPR-104	14	R54-B54
1410-3B (BM#301165)	SPR-105	10	R48-B48
ASO100-10S	SPR-140	10	L45-R45
ASO10-ESP	SPR-140	10	L45-R45
ASO10-VP10	SPR-140	10	L45-R45
ASO125-10S (BM#301579)	SPR-140	10	L45-R45
ASO140-10S (BM#301580)	SPR-140	10	L45-R45
ASO150-10S (BM#301578)	SPR-140	10	L45-R45
ASO160-10S	SPR-140	10	L45-R45
ASO165-10S (BM#301581)	SPR-140	10	L45-R45
LASO125-10S (BM#301620)	SPR-140	10	L45-R45
LASO140-10S (BM#301621)	SPR-140	10	L45-R45
LASO150-10S (BM#301622)	SPR-140	10	L45-R45
LLASO125-10S	SPR-140	10	L45-R45
LLASO140-10S	SPR-140	10	L45-R45
LLASO150-10S	SPR-140	10	L45-R45
LLPSO100-10S	SPR-140	10	L45-R45
LLPSO10-VPD	SPR-140	10	L45-R45
LLPSO125-10S	SPR-140	10	L45-R45
LLPSO140-10S	SPR-140	10	L45-R45
LLPSO150-10S	SPR-140	10	L45-R45
LLPSO165-10S	SPR-140	10	L45-R45
LPSO100-10S	SPR-140	10	L45-R45
LPSO125-10S (BM#301572)	SPR-140	10	L45-R45
LPSO140-10S (BM#301573)	SPR-140	10	L45-R45
LPSO150-10S (BM#301574)	SPR-140	10	L45-R45
LPSO165-10S	SPR-140	10	L45-R45
PS86-10V (BM#301587)	SPR-144	10	L45-R45
PSDO165-18A (Released for Mexico Market)	TTC-151	18	R52-B52
PSDO185-18A (Released for Mexico Market)	TTC-151	18	R52-B52
PSDO205-18A (Released for Mexico Market)	TTC-151	18	R52-B52
PSO100-10S (BM#301560)	SPR-140	10	L45-R45



IMPORTANT: See Safety Information in Section 1 of the Chelsea Applications catalog HY25-3000/US

Transmission PTO Driver & Apertures (Viewed from Rear of Transmission)
L-Left Side R-Right Side B-Bottom Side T-Top Side CS-Countershaft
For transmissions not listed, contact your authorized Chelsea Distributor.

TREMEC/TTC/SPICER TRANSMISSION INDEX

Transmission Make and Model	PTO Appl. Number	Number Forward Speeds	Teeth in PTO Driver
PSO10-ESP	SPR-140	10	L45-R45
PSO10-VPD	SPR-140	10	L45-R45
PSO115-10V (BM#301588)	SPR-140	10	L45-R45
PSO125-10S (BM#301561)	SPR-140	10	L45-R45
PSO125-10V (BM#301589)	SPR-140	10	L45-R45
PSO140-10S (BM#301562)	SPR-140	10	L45-R45
PSO145-10V (BM#301582)	SPR-140	10	L45-R45
PSO145-9R (BM#301625)	SPR-140	9	L45-R45
PSO150-10S (BM#301563)	SPR-140	10	L45-R45
PSO160-10S	SPR-140	10	L45-R45
PSO165-10S (BM#301564)	SPR-140	10	L45-R45
PSX150-9S (BM#301521)	SPR-140	9	L45-R45
TDET0880 (Same as TR-4050, Dodge Mexico)	TTC-150	5	R32
TDET1015 (Same as TR-4050 w/ special ratio-Ford Mexico)	TTC-150	5	R32
TDET1361 (Same as TR-4050, Chev/GMC)	TTC-150	5	R32
TDET1664 (Same as TR-4050, Ford Mexico)	TTC-150	5	R32
TR-4050 (Transmission made in Mexico)	TTC-150	5	R32



IMPORTANT: See Safety Information
in Section 1 of the Chelsea Applications
catalog HY25-3000/US

Transmission PTO Driver & Apertures (Viewed from Rear of Transmission)
L-Left Side R-Right Side B-Bottom Side T-Top Side CS-Countershaft
For transmissions not listed, contact your authorized Chelsea Distributor.

1214-3A (BM#301212 & 301130 and Later)
1214-5A (BM#301213 & 301131 and Later)

BOTTOM SIDE ONLY

RIGHT SIDE ONLY

TRANSMISSION GEAR DATA:

BOT 08-BOLT Opening Gear FORWARD of Centerline
54 Teeth - SPUR

PITCH LINE TO APERTURE FACE:

0.5660" (14.3700MM)

TRANSMISSION GEAR DATA:

R.S. 06-BOLT Opening Gear FORWARD of Centerline
54 Teeth - SPUR

PITCH LINE TO APERTURE FACE:

0.7210" (18.3100MM)

CAUTION: Application Approval Required for PTO Output Shaft Speeds Above 2500 RPM

PTO Model	Torq I / C †	Dir Rot	Engine %		Filler Block	Adapter Assy	Stud Kit	PTO Model	Torq I / C †	Dir Rot	Engine %		Filler Block	Adapter Assy	Stud Kit
			Fwd	Rev							Fwd	Rev			

ONE SPEED - TWO GEAR - MECHANICAL SHIFT

221XCAHX-*3	250 I	Opp	57		7-A-032(45)	328564X	Furnished	221XCAHX-*3	250 I	Opp	57		7-A-350 7-A-032(45)		328170-35X
221XEAHX-*3	250 I	Opp	66		7-A-062(P)	310778X	Furnished	221XEAHX-*3	250 I	Opp	66		7-A-300		328170-35X
489XAAHX-*5 (12)	250 I	Opp	50		8-A-062 8-A-093		328170-8X	442KAAHX-*3 (12)	250 I	Opp	50		7-A-300		7170-5X
489XCAHX-*5 (13)	250 I	Opp	64		8-A-062 8-A-093		328170-8X	442KCAHX-*3 (13)	250 I	Opp	64		7-A-300		7170-5X
489XFAHX-*5 (2)	250 I	Opp	80		8-A-062 8-A-093		328170-8X	442KFAHX-*3 (2)	250 I	Opp	80		7-A-300		7170-5X
489XHAHX-*5 (15)	250 I	Opp	93		8-A-062 8-A-093		328170-8X	442KHAHX-*3 (15)	250 I	Opp	93		7-A-300		7170-5X
489XLAHX-*5 (1)	250 I	Opp	103		8-A-062 8-A-093		328170-8X	442KLAHX-*3 (1)	250 I	Opp	103		7-A-300		7170-5X
489XQAHX-*5 (1)	225 I	Opp	111		8-A-062 8-A-093		328170-8X	442KQAHX-*3 (1)	225 I	Opp	111		7-A-300		7170-5X
489XRAHX-*5 (1)	225 I	Opp	128		8-A-062 8-A-093		328170-8X	442KRAHX-*3 (1)	225 I	Opp	128		7-A-300		7170-5X
489XSAHX-*5 (1)	200 I	Opp	153		8-A-062 8-A-093		328170-8X	442KSAHX-*3 (1)	200 I	Opp	153		7-A-300		7170-5X
489XUAHX-*5 (1)	195 I	Opp	182		8-A-062 8-A-093		328170-8X	442KUWAHX-*3 (1)	175 I	Opp	214		7-A-300		7170-5X
489XWAHX-*5 (1)	175 I	Opp	214		8-A-062 8-A-093		328170-8X	442KXAHX-*3 (1)	140 I	Opp	254		7-A-300		7170-5X
489XXAHX-*5 (1)	140 I	Opp	254		8-A-062 8-A-093		328170-8X	660KFAHX-*3 (10)	375 I	Opp	80		7-A-300		7170-5X
680XFAHX-*3 (10)	375 I	Opp	80		8-A-062 8-A-093		328170-8X	660KHAHX-*3 (15)	375 I	Opp	93		7-A-300		7170-5X
680XHAHX-*3 (18)	375 I	Opp	93		8-A-062 8-A-093		328170-8X	660KQAHX-*3 (11)	375 I	Opp	111		7-A-300		7170-5X
680XQAHX-*3 (11)	375 I	Opp	111		8-A-062 8-A-093		328170-8X	660KRAHX-*3 (17)	350 I	Opp	128		7-A-300		7170-5X

Continued on Next Page

† I = Intermittent Torque Only - De-rate Torque Rating 30% for Continuous Duty.

C = Continuous or Intermittent Torque - No need to De-Rate Torque Rating.

IMPORTANT: Refer to the back of this transmission section and read all notes associated with this application page. Some notes may affect the proper PTO selection.

CAUTION: Do not use geared adapters with 442 A and C ratios.

- (1) Input Gear Part No. 5-P-1004
- (2) Input Gear Part No. 5-P-1077
- (10) Input Gear Part No. 5-P-1242
- (11) Input Gear Part No. 5-P-1246
- (12) Input Gear Part No. 5-P-1280

- (13) Input Gear Part No. 5-P-1287
- (15) Input Gear Part No. 5-P-1364
- (17) Input Gear Part No. 5-P-1441
- (18) Input Gear Part No. 5-P-1494
- (45) Furnished, but not required

SPR-104

TREMEC/TTC/SPICER

CHELSEA®

1214-3A (BM#301212 & 301130 and Later)
1214-5A (BM#301213 & 301131 and Later)

BOTTOM SIDE ONLY

RIGHT SIDE ONLY

TRANSMISSION GEAR DATA:

BOT 08-BOLT Opening Gear FORWARD of Centerline
54 Teeth - SPUR

PITCH LINE TO APERTURE FACE:

0.5660" (14.3700MM)

TRANSMISSION GEAR DATA:

R.S. 06-BOLT Opening Gear FORWARD of Centerline
54 Teeth - SPUR

PITCH LINE TO APERTURE FACE:

0.7210" (18.3100MM)

CAUTION: Application Approval Required for PTO Output Shaft Speeds Above 2500 RPM

PTO Model	Torq l / C †	Dir Rot	Engine %		Filler Block	Adapter Assy	Stud Kit	PTO Model	Torq l / C †	Dir Rot	Engine %		Filler Block	Adapter Assy	Stud Kit
			Fwd	Rev							Fwd	Rev			

ONE SPEED - TWO GEAR - MECHANICAL SHIFT

680XRAHX-*3 (17)	350 l	Opp	128		8-A-062 8-A-093		328170-8X	660KSAHX-*3 (14)	325 l	Opp	153		7-A-300		7170-5X
680XSAHX-*3 (14)	325 l	Opp	153		8-A-062 8-A-093		328170-8X								
823XBAHX-*3 (38)	500 l	Opp	54		8-A-165		328170-14X								
823XDAHX-*3 (42)	500 l	Opp	64		8-A-165		328170-14X								
823XGAHX-*3 (43)	500 l	Opp	70		8-A-165		328170-14X								
823XJAHX-*3 (39)	500 l	Opp	82		8-A-165		328170-14X								
823XMAHX-*3 (37)	500 l	Opp	96		8-A-165		328170-14X								
823XRAHX-*3 (41)	400 l	Opp	133		8-A-165		328170-14X								
880XBAHX-*3 (3)	500 l	Opp	54		8-A-165		328170-14X								
880XDAHX-*3 (4)	500 l	Opp	64		8-A-165		328170-14X								
880XGAHX-*3 (9)	500 l	Opp	70		8-A-165		328170-14X								
880XJAHX-*3 (5)	500 l	Opp	82		8-A-165		328170-14X								
880XMAHX-*3 (6)	500 l	Opp	96		8-A-165		328170-14X								
880XQAHX-*3 (16)	450 l	Opp	113		8-A-165		328170-14X								
880XRAHX-*3 (7)	400 l	Opp	133		8-A-165		328170-14X								
880XTAHX-*3 (8)	350 l	Opp	171		8-A-165		328170-14X								

ONE SPEED - TWO GEAR POWERSHIFT (AIR OR HYDRAULIC)

282XBAJX-*3 (19)	300 C	Opp	54		8-A-248 8-A-032		328170-8X	272XAAJX-*3 (28)	300 C	Opp	44		7-A-300		328170-172X
282XCAJX-*3 (20)	300 C	Opp	66		8-A-248 8-A-032		328170-8X	272XBAJX-*3 (29)	300 C	Opp	54		7-A-300		328170-172X
282XDAJX-*3 (21)	300 C	Opp	78		8-A-248 8-A-032		328170-8X	272XCAJX-*3 (30)	300 C	Opp	66		7-A-300		328170-172X
282XGAJX-*3 (22)	300 C	Opp	93		8-A-248 8-A-032		328170-8X	272XDAJX-*3 (31)	300 C	Opp	78		7-A-300		328170-172X
282XKAJX-*3 (23)	274 C	Opp	104		8-A-248 8-A-032		328170-8X	272XGAJX-*3 (32)	300 C	Opp	93		7-A-300		328170-172X
282XMAJX-*3 (24)	245 C	Opp	117		8-A-248 8-A-032		328170-8X	272XKAJX-*3 (33)	300 C	Opp	104		7-A-300		328170-172X

Continued on Next Page

† l = Intermittent Torque Only - De-rate Torque Rating 30% for Continuous Duty.

C = Continuous or Intermittent Torque - No need to De-Rate Torque Rating.

IMPORTANT: Refer to the back of this transmission section and read all notes associated with this application page.
Some notes may affect the proper PTO selection.**CAUTION:** Do not use geared adapters with 442 A and C ratios.(3) Input Gear Part No. 5-P-1100
(4) Input Gear Part No. 5-P-1101
(5) Input Gear Part No. 5-P-1102
(6) Input Gear Part No. 5-P-1103
(7) Input Gear Part No. 5-P-1104
(8) Input Gear Part No. 5-P-1105(9) Input Gear Part No. 5-P-1135
(14) Input Gear Part No. 5-P-1322
(16) Input Gear Part No. 5-P-1385
(17) Input Gear Part No. 5-P-1441
(19) Input Gear Part No. 5-P-1510-11X
(20) Input Gear Part No. 5-P-1510-12X(21) Input Gear Part No. 5-P-1510-13X
(22) Input Gear Part No. 5-P-1510-14X
(23) Input Gear Part No. 5-P-1510-15X
(24) Input Gear Part No. 5-P-1510-16X
(28) Input Gear Part No. 5-P-1510-1X
(29) Input Gear Part No. 5-P-1510-2X(30) Input Gear Part No. 5-P-1510-3X
(31) Input Gear Part No. 5-P-1510-4X
(32) Input Gear Part No. 5-P-1510-5X
(33) Input Gear Part No. 5-P-1510-6X
(37) Input Gear Part No. 5-P-283
(38) Input Gear Part No. 5-P-285(39) Input Gear Part No. 5-P-325
(41) Input Gear Part No. 5-P-721
(42) Input Gear Part No. 5-P-971
(43) Input Gear Part No. 5-P-980

CHELSEA®

TREMEC/TTC/SPICER

SPR-104

1214-3A (BM#301212 & 301130 and Later)
1214-5A (BM#301213 & 301131 and Later)

BOTTOM SIDE ONLY

RIGHT SIDE ONLY

TRANSMISSION GEAR DATA:

BOT 08-BOLT Opening Gear FORWARD of Centerline
54 Teeth - SPUR

PITCH LINE TO APERTURE FACE:

0.5660" (14.3700MM)

TRANSMISSION GEAR DATA:

R.S. 06-BOLT Opening Gear FORWARD of Centerline
54 Teeth - SPUR

PITCH LINE TO APERTURE FACE:

0.7210" (18.3100MM)

CAUTION: Application Approval Required for PTO Output Shaft Speeds Above 2500 RPM

PTO Model	Torq I / C †	Dir Rot	Engine %		Filler Block	Adapter Assy	Stud Kit	PTO Model	Torq I / C †	Dir Rot	Engine %		Filler Block	Adapter Assy	Stud Kit
			Fwd	Rev							Fwd	Rev			
ONE SPEED - TWO GEAR POWERSHIFT (AIR OR HYDRAULIC)															
282XPAJX-*3 (25)	219 C	Opp	130		8-A-248 8-A-032		328170-8X	272XMAJX-*3 (34)	300 C	Opp	117		7-A-300		328170-172X
282XSAJX-*3 (26)	196 C	Opp	146		8-A-248 8-A-032		328170-8X	272XPAJX-*3 (35)	300 C	Opp	130		7-A-300		328170-172X
282XTAJX-*3 (27)	175 C	Opp	163		8-A-248 8-A-032		328170-8X	272XSAJX-*3 (36)	300 C	Opp	146		7-A-300		328170-172X
ONE SPEED - POWERSHIFT LOW PROFILE (AIR OR HYDRAULIC)															
								272MAAJX-*3 (28)	300 C	Opp	44		7-A-300		328170-172X
								272MBAJX-*3 (29)	300 C	Opp	54		7-A-300		328170-172X
								272MCAJX-*3 (30)	300 C	Opp	66		7-A-300		328170-172X
								272MDAJX-*3 (31)	300 C	Opp	78		7-A-300		328170-172X
								272MGAJX-*3 (32)	300 C	Opp	93		7-A-300		328170-172X
								272MKAJX-*3 (33)	300 C	Opp	104		7-A-300		328170-172X
								272MMAJX-*3 (34)	300 C	Opp	117		7-A-300		328170-172X
								272MPAJX-*3 (35)	300 C	Opp	130		7-A-300		328170-172X
								272MSAJX-*3 (36)	300 C	Opp	146		7-A-300		328170-172X
ONE SPEED - TWO GEAR - POWERSHIFT (AIR)															
885XBAHX-*3 (3)	500 I	Opp	54		8-A-165		328170-14X								
885XGAHX-*3 (9)	500 I	Opp	70		8-A-165		328170-14X								
885XJAHX-*3 (5)	500 I	Opp	82		8-A-165		328170-14X								
885XMAHX-*3 (6)	500 I	Opp	96		8-A-165		328170-14X								
ONE SPEED - FORWARD & REVERSE															
348KFAHX-*5 (40)	200 I	Opp	70	73	8-A-190		328170-8X	340XFAHX-*5 (40)	200 I	Opp	70	73	7-A-140(44) 7-A-270		7170-5X
863XBAHX-*5	500 I	Opp	54	67	8-A-165		328170-14X								
GEARED ADAPTERS															
628XAHX-3AH	250 I	Eng			8-A-190		328170-8X	626KAHX-4AH	250 I	Eng			7-A-300		7170-5X

Continued on Next Page

† I = Intermittent Torque Only - De-rate Torque Rating 30% for Continuous Duty.

C = Continuous or Intermittent Torque - No need to De-Rate Torque Rating.

IMPORTANT: Refer to the back of this transmission section and read all notes associated with this application page.
Some notes may affect the proper PTO selection.

CAUTION: Do not use geared adapters with 442 A and C ratios.

(3) Input Gear Part No. 5-P-1100
(5) Input Gear Part No. 5-P-1102
(6) Input Gear Part No. 5-P-1103
(9) Input Gear Part No. 5-P-1135
(25) Input Gear Part No. 5-P-1510-17X

(26) Input Gear Part No. 5-P-1510-18X
(27) Input Gear Part No. 5-P-1510-19X
(28) Input Gear Part No. 5-P-1510-1X
(29) Input Gear Part No. 5-P-1510-2X
(30) Input Gear Part No. 5-P-1510-3X

(31) Input Gear Part No. 5-P-1510-4X
(32) Input Gear Part No. 5-P-1510-5X
(33) Input Gear Part No. 5-P-1510-6X
(34) Input Gear Part No. 5-P-1510-7X
(35) Input Gear Part No. 5-P-1510-8X

(36) Input Gear Part No. 5-P-1510-9X
(40) Input Gear Part No. 5-P-581
(44) Filler block furnished with PTO

SPR-104

TREMEC/TTC/SPICER

CHELSEA®

1214-3A (BM#301212 & 301130 and Later)
1214-5A (BM#301213 & 301131 and Later)

BOTTOM SIDE ONLY

RIGHT SIDE ONLY

TRANSMISSION GEAR DATA:

BOT 08-BOLT Opening Gear FORWARD of Centerline
54 Teeth - SPUR

PITCH LINE TO APERTURE FACE:

0.5660" (14.3700MM)

TRANSMISSION GEAR DATA:

R.S. 06-BOLT Opening Gear FORWARD of Centerline
54 Teeth - SPUR

PITCH LINE TO APERTURE FACE:

0.7210" (18.3100MM)

CAUTION: Application Approval Required for PTO Output Shaft Speeds Above 2500 RPM

PTO Model	Torq	Dir Rot	Engine %		Filler Block	Adapter Assy	Stud Kit	PTO Model	Torq	Dir Rot	Engine %		Filler Block	Adapter Assy	Stud Kit
	I / C †		Fwd	Rev					I / C †		Fwd	Rev			

GEARED ADAPTERS

630KAHX-3AH	250 I	Eng	7-A-300	7170-5X
645KAHX-3AH	250 I	Eng	7-A-300	7170-5X

† I = Intermittent Torque Only - De-rate Torque Rating 30% for Continuous Duty.

C = Continuous or Intermittent Torque - No need to De-Rate Torque Rating.

IMPORTANT: Refer to the back of this transmission section and read all notes associated with this application page. Some notes may affect the proper PTO selection.

CAUTION: Do not use geared adapters with 442 A and C ratios.

Tremec/TTC/Spicer

CHELSEA®

TREMEC/TTC/SPICER

SPR-105

1010-3B (BM#301115 and Later)
1020-3A (BM#301125 and Later)
1020-5A (BM#301126 and Later)
1410-3B (BM#301165)

BOTTOM SIDE ONLY

RIGHT SIDE ONLY

TRANSMISSION GEAR DATA:

BOT 08-BOLT Opening Gear FORWARD of Centerline
48 Teeth - SPUR

PITCH LINE TO APERTURE FACE:

1.0660" (27.0800MM)

TRANSMISSION GEAR DATA:

R.S. 06-BOLT Opening Gear FORWARD of Centerline
48 Teeth - SPUR

PITCH LINE TO APERTURE FACE:

1.2210" (31.0100MM)

CAUTION: Application Approval Required for PTO Output Shaft Speeds Above 2500 RPM

PTO Model	Torq I / C †	Dir Rot	Engine %		Filler Block	Adapter Assy	Stud Kit	PTO Model	Torq I / C †	Dir Rot	Engine %		Filler Block	Adapter Assy	Stud Kit
			Fwd	Rev							Fwd	Rev			
ONE SPEED - TWO GEAR - MECHANICAL SHIFT															
221ZCAHX-*3	250 I	Opp	56		7-A-062(P) 7-A-032(42)	328481X	Furnished	221ZCAHX-*3	250 I	Opp	56		7-A-165 7-A-032(42)		328170-1X
221ZEAHX-*3	250 I	Opp	64		7-A-032(P)	328481X	Furnished	221ZEAHX-*3	250 I	Opp	64		7-A-140		328170-1X
823ZBAHX-*3 (36)	500 I	Opp	53		8-A-700		328170-133X	442LAAHX-*3 (11)	250 I	Opp	49		7-A-140		328170-76X
823ZDAHX-*3 (40)	500 I	Opp	62		8-A-700		328170-133X	442LCAHX-*3 (12)	250 I	Opp	63		7-A-140		328170-76X
823ZGAHX-*3 (41)	500 I	Opp	68		8-A-700		328170-133X	442LFAHX-*3 (2)	250 I	Opp	77		7-A-140		328170-76X
823ZJAHX-*3 (37)	500 I	Opp	80		8-A-700		328170-133X	442LHAHX-*3 (14)	250 I	Opp	89		7-A-140		328170-76X
823ZMAHX-*3 (35)	500 I	Opp	94		8-A-700		328170-133X	442LLAHX-*3 (1)	250 I	Opp	100		7-A-140		328170-76X
823ZRAHX-*3 (39)	400 I	Opp	129		8-A-700		328170-133X	442LQAHX-*3 (1)	225 I	Opp	108		7-A-140		328170-76X
880ZBAHX-*3 (3)	500 I	Opp	53		8-A-700		328170-133X	442LRAHX-*3 (1)	225 I	Opp	125		7-A-140		328170-76X
880ZDAHX-*3 (4)	500 I	Opp	62		8-A-700		328170-133X	442LSAHX-*3 (1)	200 I	Opp	149		7-A-140		328170-76X
880ZGAHX-*3 (8)	500 I	Opp	68		8-A-700		328170-133X	442LUAHX-*3 (1)	195 I	Opp	177		7-A-140		328170-76X
880ZJAHX-*3 (5)	500 I	Opp	80		8-A-700		328170-133X	442LWAHX-*3 (1)	175 I	Opp	209		7-A-140		328170-76X
880ZMAHX-*3 (6)	500 I	Opp	94		8-A-700		328170-133X	442LXAHX-*3 (1)	140 I	Opp	247		7-A-140		328170-76X
880ZQAHX-*3 (15)	450 I	Opp	109		8-A-700		328170-133X	660LFAHX-*3 (9)	375 I	Opp	77		7-A-140		328170-76X
880ZRAHX-*3 (7)	400 I	Opp	129		8-A-700		328170-133X	660LHAHX-*3 (14)	375 I	Opp	89		7-A-140		328170-76X
								660LQAHX-*3 (10)	375 I	Opp	108		7-A-140		328170-76X
								660LRAHX-*3 (16)	350 I	Opp	125		7-A-140		328170-76X
								660LSAHX-*3 (13)	325 I	Opp	149		7-A-140		328170-76X

ONE SPEED - TWO GEAR POWERSHIFT (AIR OR HYDRAULIC)

282XBAJX-*3 (17)	300 C	Opp	53		8-A-032		Furnished	272XAAJX-*3 (26)	300 C	Opp	43				Furnished
282XCAJX-*3 (18)	300 C	Opp	64		8-A-032		Furnished	272XBAJX-*3 (27)	300 C	Opp	53				Furnished
282XD AJX-*3 (19)	300 C	Opp	76		8-A-032		Furnished	272XCAJX-*3 (28)	300 C	Opp	64				Furnished
282XGAJX-*3 (20)	300 C	Opp	91		8-A-032		Furnished	272XD AJX-*3 (29)	300 C	Opp	76				Furnished
282XKAJX-*3 (21)	300 C	Opp	102		8-A-032		Furnished	272XGAJX-*3 (30)	300 C	Opp	91				Furnished
282XMAJX-*3 (22)	275 C	Opp	114		8-A-032		Furnished	272XKAJX-*3 (31)	300 C	Opp	102				Furnished
282XPAJX-*3 (23)	246 C	Opp	246		8-A-032		Furnished	272XMAJX-*3 (32)	300 C	Opp	114				Furnished
282XSAJX-*3 (24)	220 C	Opp	142		8-A-032		Furnished	272XPAJX-*3 (33)	300 C	Opp	246				Furnished
282XTAJX-*3 (25)	197 C	Opp	159		8-A-032		Furnished	272XSAJX-*3 (34)	300 C	Opp	142				Furnished

Continued on Next Page

† I = Intermittent Torque Only - De-rate Torque Rating 30% for Continuous Duty.

C = Continuous or Intermittent Torque - No need to De-Rate Torque Rating.

IMPORTANT: Refer to the back of this transmission section and read all notes associated with this application page.
Some notes may affect the proper PTO selection.**CAUTION:** Do not use geared adapters with 442 A and C ratios.

- (1) Input Gear Part No. 5-P-1004
- (2) Input Gear Part No. 5-P-1077
- (3) Input Gear Part No. 5-P-1100
- (4) Input Gear Part No. 5-P-1101
- (5) Input Gear Part No. 5-P-1102
- (6) Input Gear Part No. 5-P-1103
- (7) Input Gear Part No. 5-P-1104
- (8) Input Gear Part No. 5-P-1135

- (9) Input Gear Part No. 5-P-1242
- (10) Input Gear Part No. 5-P-1246
- (11) Input Gear Part No. 5-P-1280
- (12) Input Gear Part No. 5-P-1287
- (13) Input Gear Part No. 5-P-1322
- (14) Input Gear Part No. 5-P-1364
- (15) Input Gear Part No. 5-P-1385
- (16) Input Gear Part No. 5-P-1441

- (17) Input Gear Part No. 5-P-1510-11X
- (18) Input Gear Part No. 5-P-1510-12X
- (19) Input Gear Part No. 5-P-1510-13X
- (20) Input Gear Part No. 5-P-1510-14X
- (21) Input Gear Part No. 5-P-1510-15X
- (22) Input Gear Part No. 5-P-1510-16X
- (23) Input Gear Part No. 5-P-1510-17X
- (24) Input Gear Part No. 5-P-1510-18X

- (25) Input Gear Part No. 5-P-1510-19X
- (26) Input Gear Part No. 5-P-1510-1X
- (27) Input Gear Part No. 5-P-1510-2X
- (28) Input Gear Part No. 5-P-1510-3X
- (29) Input Gear Part No. 5-P-1510-4X
- (30) Input Gear Part No. 5-P-1510-5X
- (31) Input Gear Part No. 5-P-1510-6X
- (32) Input Gear Part No. 5-P-1510-7X

- (33) Input Gear Part No. 5-P-1510-8X
- (34) Input Gear Part No. 5-P-1510-9X
- (35) Input Gear Part No. 5-P-283
- (36) Input Gear Part No. 5-P-285
- (37) Input Gear Part No. 5-P-325
- (38) Input Gear Part No. 5-P-721
- (39) Input Gear Part No. 5-P-971
- (40) Input Gear Part No. 5-P-971
- (41) Input Gear Part No. 5-P-980

SPR-105

TREMEC/TTC/SPICER

CHELSEA®

1010-3B (BM#301115 and Later)
1020-3A (BM#301125 and Later)
1020-5A (BM#301126 and Later)
1410-3B (BM#301165)

BOTTOM SIDE ONLY

RIGHT SIDE ONLY

TRANSMISSION GEAR DATA:

BOT 08-BOLT Opening Gear FORWARD of Centerline
48 Teeth - SPUR

PITCH LINE TO APERTURE FACE:

1.0660" (27.0800MM)

TRANSMISSION GEAR DATA:

R.S. 06-BOLT Opening Gear FORWARD of Centerline
48 Teeth - SPUR

PITCH LINE TO APERTURE FACE:

1.2210" (31.0100MM)

CAUTION: Application Approval Required for PTO Output Shaft Speeds Above 2500 RPM

PTO Model	Torq I / C †	Dir Rot	Engine %		Filler Block	Adapter Assy	Stud Kit	PTO Model	Torq I / C †	Dir Rot	Engine %		Filler Block	Adapter Assy	Stud Kit
			Fwd	Rev							Fwd	Rev			

ONE SPEED - POWERSHIFT LOW PROFILE (AIR OR HYDRAULIC)

272MAAJX-*3 (26)	300 C	Opp	43												Furnished
272MBAJX-*3 (27)	300 C	Opp	53												Furnished
272MCAJX-*3 (28)	300 C	Opp	64												Furnished
272MDAJX-*3 (29)	300 C	Opp	76												Furnished
272MGAJX-*3 (30)	300 C	Opp	91												Furnished
272MKAJX-*3 (31)	300 C	Opp	102												Furnished
272MMAJX-*3 (32)	300 C	Opp	114												Furnished
272MPAJX-*3 (33)	300 C	Opp	246												Furnished
272MSAJX-*3 (34)	300 C	Opp	142												Furnished

ONE SPEED - TWO GEAR - POWERSHIFT (AIR)

885ZBAHX-*3 (3)	500 I	Opp	53	8-A-700	328170-133X
885ZGAHX-*3 (8)	500 I	Opp	68	8-A-700	328170-133X
885ZJAHX-*3 (5)	500 I	Opp	80	8-A-700	328170-133X
885ZMAHX-*3 (6)	500 I	Opp	94	8-A-700	328170-133X

ONE SPEED - FORWARD & REVERSE

340SFAHX-*5 (38)	200 I	Opp	68	71	7-A-062	328170-94X
------------------	-------	-----	----	----	---------	------------

† I = Intermittent Torque Only - De-rate Torque Rating 30% for Continuous Duty.

C = Continuous or Intermittent Torque - No need to De-Rate Torque Rating.

IMPORTANT: Refer to the back of this transmission section and read all notes associated with this application page. Some notes may affect the proper PTO selection.

CAUTION: Do not use geared adapters with 442 A and C ratios.

- | | | |
|--------------------------------------|--------------------------------------|--------------------------------------|
| (3) Input Gear Part No. 5-P-1100 | (27) Input Gear Part No. 5-P-1510-2X | (32) Input Gear Part No. 5-P-1510-7X |
| (5) Input Gear Part No. 5-P-1102 | (28) Input Gear Part No. 5-P-1510-3X | (33) Input Gear Part No. 5-P-1510-8X |
| (6) Input Gear Part No. 5-P-1103 | (29) Input Gear Part No. 5-P-1510-4X | (34) Input Gear Part No. 5-P-1510-9X |
| (8) Input Gear Part No. 5-P-1135 | (30) Input Gear Part No. 5-P-1510-5X | (38) Input Gear Part No. 5-P-581 |
| (26) Input Gear Part No. 5-P-1510-1X | (31) Input Gear Part No. 5-P-1510-6X | |

ASO10-ESP ASO10-VP10 ASO100-10S ASO125-10S (BM#301579) ASO140-10S (BM#301580) ASO150-10S (BM#301578) ASO160-10S ASO165-10S (BM#301581)	LASO125-10S (BM#301620) LASO140-10S (BM#301621) LASO150-10S (BM#301622) LLASO125-10S LLASO140-10S LLASO150-10S LLASO10-VPD LLPSO100-10S	LLPSO125-10S LLPSO140-10S LLPSO150-10S LLPSO165-10S LPSO100-10S LPSO125-10S (BM#301572) LPSO140-10S (BM#301573) LPSO150-10S (BM#301574)
---	--	--

LEFT SIDE ONLY	RIGHT SIDE ONLY
TRANSMISSION GEAR DATA: L.S. 08-BOLT Opening Gear FORWARD of Centerline 45 Teeth - SPUR PITCH LINE TO APERTURE FACE: 0.7300" (18.5420MM)	TRANSMISSION GEAR DATA: R.S. 06-BOLT Opening Gear REAR of Centerline 45 Teeth - SPUR PITCH LINE TO APERTURE FACE: 1.0750" (27.3050MM)

CAUTION: Application Approval Required for PTO Output Shaft Speeds Above 2500 RPM

PTO Model	Torq I / C †	Dir Rot	Engine %		Filler Block	Adapter Assy	Stud Kit	PTO Model	Torq I / C †	Dir Rot	Engine %		Filler Block	Adapter Assy	Stud Kit
			Fwd	Rev							Fwd	Rev			

ONE SPEED - TWO GEAR - MECHANICAL SHIFT

221XCAHX-*5	250 I	Opp	71		7-A-062 7-A-032(37)	328481X	Furnished	221XCAHX-*4	250 I	Opp	71		7-A-062 7-A-032(37)		Furnished
221XEAHX-*5	250 I	Opp	82			328481X	Furnished	221XEAHX-*4	250 I	Opp	82				Furnished
489XAAHX-*5 (12)	250 I	Opp	62				Furnished	442XFAHX-*4 (2)	250 I	Opp	98				Furnished
489XCAHX-*5 (13)	250 I	Opp	80				Furnished	442XHAHX-*4 (15)	250 I	Opp	114				Furnished
489XFAHX-*5 (2)	250 I	Opp	98				Furnished	442XLAHX-*4 (1)	250 I	Opp	127				Furnished
489XHAHX-*5 (15)	250 I	Opp	114				Furnished	442XQAHX-*4 (1)	225 I	Opp	137				Furnished
489XLAHX-*5 (1)	250 I	Opp	127				Furnished	442XRAHX-*4 (1)	225 I	Opp	159				Furnished
489XQAHX-*5 (1)	225 I	Opp	137				Furnished	442XSAHX-*4 (1)	200 I	Opp	189				Furnished
489XRAHX-*5 (1)	225 I	Opp	159				Furnished	442XUAHX-*4 (1)	195 I	Opp	225				Furnished
489XSAHX-*5 (1)	200 I	Opp	189				Furnished	442XWAHX-*4 (1)	175 I	Opp	265				Furnished
489XUAHX-*5 (1)	195 I	Opp	225				Furnished	442XXAHX-*4 (1)	140 I	Opp	313				Furnished
489XWAHX-*5 (1)	175 I	Opp	265				Furnished	660XFAHX-*4 (10)	375 I	Opp	98				Furnished
489XXAHX-*5 (1)	140 I	Opp	313				Furnished	660XHAHX-*4 (15)	375 I	Opp	114				Furnished
680XFAHX-*5 (10)	375 I	Opp	98				Furnished	660XQAHX-*4 (11)	375 I	Opp	137				Furnished
680XHAHX-*5 (19)	375 I	Opp	114				Furnished	660XRAHX-*4 (18)	350 I	Opp	159				Furnished
680XQAHX-*5 (11)	375 I	Opp	137				Furnished	660XSAHX-*4 (14)	325 I	Opp	189				Furnished
680XRAHX-*5 (18)	350 I	Opp	159				Furnished								
680XSAHX-*5 (14)	325 I	Opp	189				Furnished								
823XBAHX-*5 (30)	500 I	Opp	67				Furnished								
823XDAHX-*5 (34)	500 I	Opp	79				Furnished								
823XGAHX-*5 (35)	500 I	Opp	86				Furnished								
823XJAHX-*5 (31)	500 I	Opp	101				Furnished								
823XMAHX-*5 (29)	500 I	Opp	119				Furnished								
823XRAHX-*5 (33)	400 I	Opp	164				Furnished								
823XTKTX-*5 (17)	350 I	Opp	199		8-A-165(36)		Furnished								
880XBAHX-*5 (3)	500 I	Opp	67				Furnished								
880XDAHX-*5 (4)	500 I	Opp	79				Furnished								
880XGAHX-*5 (9)	500 I	Opp	86				Furnished								
880XJAHX-*5 (5)	500 I	Opp	101				Furnished								
880XMAHX-*5 (6)	500 I	Opp	119				Furnished								
880XQAHX-*5 (16)	450 I	Opp	139				Furnished								

Continued on Next Page

† I = Intermittent Torque Only - De-rate Torque Rating 30% for Continuous Duty.

C = Continuous or Intermittent Torque - No need to De-Rate Torque Rating.

IMPORTANT: Refer to the back of this transmission section and read all notes associated with this application page. Some notes may affect the proper PTO selection.

CAUTION: Do not use geared adapters with 442 A and C ratios.

- | | | | | |
|----------------------------------|-----------------------------------|-----------------------------------|-----------------------------------|--------------------------------------|
| (1) Input Gear Part No. 5-P-1004 | (6) Input Gear Part No. 5-P-1103 | (13) Input Gear Part No. 5-P-1287 | (18) Input Gear Part No. 5-P-1441 | (33) Input Gear Part No. 5-P-921 |
| (2) Input Gear Part No. 5-P-1077 | (9) Input Gear Part No. 5-P-1135 | (14) Input Gear Part No. 5-P-1322 | (19) Input Gear Part No. 5-P-1494 | (34) Input Gear Part No. 5-P-971 |
| (3) Input Gear Part No. 5-P-1100 | (10) Input Gear Part No. 5-P-1242 | (15) Input Gear Part No. 5-P-1364 | (29) Input Gear Part No. 5-P-283 | (35) Input Gear Part No. 5-P-980 |
| (4) Input Gear Part No. 5-P-1101 | (11) Input Gear Part No. 5-P-1246 | (16) Input Gear Part No. 5-P-1385 | (30) Input Gear Part No. 5-P-285 | (36) Filler block furnished with PTO |
| (5) Input Gear Part No. 5-P-1102 | (12) Input Gear Part No. 5-P-1280 | (17) Input Gear Part No. 5-P-1395 | (31) Input Gear Part No. 5-P-325 | (37) Furnished, but not required |

SPR-140

TREMEC/TTC/SPICER



ASO10-ESP	LASO125-10S (BM#301620)	LLPSO125-10S
ASO10-VP10	LASO140-10S (BM#301621)	LLPSO140-10S
ASO100-10S	LASO150-10S (BM#301622)	LLPSO150-10S
ASO125-10S (BM#301579)	LLASO125-10S	LLPSO165-10S
ASO140-10S (BM#301580)	LLASO140-10S	LPSO100-10S
ASO150-10S (BM#301578)	LLASO150-10S	LPSO125-10S (BM#301572)
ASO160-10S	LLPSO10-VPD	LPSO140-10S (BM#301573)
ASO165-10S (BM#301581)	LLPSO100-10S	LPSO150-10S (BM#301574)

LEFT SIDE ONLY	RIGHT SIDE ONLY
-----------------------	------------------------

<p>TRANSMISSION GEAR DATA: L.S. 08-BOLT Opening Gear FORWARD of Centerline 45 Teeth - SPUR PITCH LINE TO APERTURE FACE: 0.7300" (18.5420MM)</p>	<p>TRANSMISSION GEAR DATA: R.S. 06-BOLT Opening Gear REAR of Centerline 45 Teeth - SPUR PITCH LINE TO APERTURE FACE: 1.0750" (27.3050MM)</p>
---	--

CAUTION: Application Approval Required for PTO Output Shaft Speeds Above 2500 RPM

PTO Model	Torq I / C †	Dir Rot	Engine %		Filler Block	Adapter Assy	Stud Kit	PTO Model	Torq I / C †	Dir Rot	Engine %		Filler Block	Adapter Assy	Stud Kit
			Fwd	Rev							Fwd	Rev			

ONE SPEED - TWO GEAR - MECHANICAL SHIFT

880XRAHX-*5 (7)	400 I	Opp	164				Furnished								
880XTAHX-*5 (8)	350 I	Opp	212				Furnished								

ONE SPEED - TWO GEAR POWERSHIFT (AIR OR HYDRAULIC)

282XBAJX-*5 (20)	300 C	Opp	67		8-A-093		Furnished								
					8-A-032										
282XCAJX-*5 (21)	300 C	Opp	81		8-A-093		Furnished								
					8-A-032										
282XDAJX-*5 (22)	300 C	Opp	97		8-A-093		Furnished								
					8-A-032										
282XGAJX-*5 (23)	300 C	Opp	115		8-A-093		Furnished								
					8-A-032										
282XKAJX-*5 (24)	300 C	Opp	129		8-A-093		Furnished								
					8-A-032										
282XMAJX-*5 (25)	300 C	Opp	144		8-A-093		Furnished								
					8-A-032										
282XPAJX-*5 (26)	300 C	Opp	161		8-A-093		Furnished								
					8-A-032										
282XSAJX-*5 (27)	278 C	Opp	180		8-A-093		Furnished								
					8-A-032										
282XTAJX-*5 (28)	248 C	Opp	202		8-A-093		Furnished								
					8-A-032										

ONE SPEED - TWO GEAR - POWERSHIFT (AIR)

885XBAHX-*5 (3)	500 I	Opp	67				Furnished								
885XGAHX-*5 (9)	500 I	Opp	86				Furnished								
885XJAHX-*5 (5)	500 I	Opp	101				Furnished								
885XMAHX-*5 (6)	500 I	Opp	119				Furnished								

ONE SPEED - FORWARD & REVERSE

348XFAHX-*5 (32)	200 I	Opp	86	90			Furnished	340XFAHX-*4 (32)	200 I	Opp	86	90	7-A-140(36)		Furnished
------------------	-------	-----	----	----	--	--	-----------	------------------	-------	-----	----	----	-------------	--	-----------

Continued on Next Page

† I = Intermittent Torque Only - De-rate Torque Rating 30% for Continuous Duty. C = Continuous or Intermittent Torque - No need to De-Rate Torque Rating.

IMPORTANT: Refer to the back of this transmission section and read all notes associated with this application page. Some notes may affect the proper PTO selection.

CAUTION: Do not use geared adapters with 442 A and C ratios.

- | | | | |
|----------------------------------|---------------------------------------|---------------------------------------|--------------------------------------|
| (3) Input Gear Part No. 5-P-1100 | (9) Input Gear Part No. 5-P-1135 | (24) Input Gear Part No. 5-P-1510-15X | (32) Input Gear Part No. 5-P-581 |
| (5) Input Gear Part No. 5-P-1102 | (20) Input Gear Part No. 5-P-1510-11X | (25) Input Gear Part No. 5-P-1510-16X | (36) Filler block furnished with PTO |
| (6) Input Gear Part No. 5-P-1103 | (21) Input Gear Part No. 5-P-1510-12X | (26) Input Gear Part No. 5-P-1510-17X | |
| (7) Input Gear Part No. 5-P-1104 | (22) Input Gear Part No. 5-P-1510-13X | (27) Input Gear Part No. 5-P-1510-18X | |
| (8) Input Gear Part No. 5-P-1105 | (23) Input Gear Part No. 5-P-1510-14X | (28) Input Gear Part No. 5-P-1510-19X | |

Tremec/TTC/Spicer



October 2022
5.14.10

Parker Hannifin Corporation
Chelsea Products Division
Olive Branch, MS 38654 USA

CHELSEA®

TREMEC/TTC/SPICER

SPR-140

ASO10-ESP	LASO125-10S (BM#301620)	LLPSO125-10S
ASO10-VP10	LASO140-10S (BM#301621)	LLPSO140-10S
ASO100-10S	LASO150-10S (BM#301622)	LLPSO150-10S
ASO125-10S (BM#301579)	LLASO125-10S	LLPSO165-10S
ASO140-10S (BM#301580)	LLASO140-10S	LPSO100-10S
ASO150-10S (BM#301578)	LLASO150-10S	LPSO125-10S (BM#301572)
ASO160-10S	LLPSO10-VPD	LPSO140-10S (BM#301573)
ASO165-10S (BM#301581)	LLPSO100-10S	LPSO150-10S (BM#301574)

LEFT SIDE ONLY	RIGHT SIDE ONLY
TRANSMISSION GEAR DATA: L.S. 08-BOLT Opening Gear FORWARD of Centerline 45 Teeth - SPUR PITCH LINE TO APERTURE FACE: 0.7300" (18.5420MM)	TRANSMISSION GEAR DATA: R.S. 06-BOLT Opening Gear REAR of Centerline 45 Teeth - SPUR PITCH LINE TO APERTURE FACE: 1.0750" (27.3050MM)

CAUTION: Application Approval Required for PTO Output Shaft Speeds Above 2500 RPM

PTO Model	Torq	Dir Rot	Engine %		Filler Block	Adapter Assy	Stud Kit	PTO Model	Torq	Dir Rot	Engine %		Filler Block	Adapter Assy	Stud Kit
	I / C †		Fwd	Rev					I / C †		Fwd	Rev			

ONE SPEED - FORWARD & REVERSE

348ZFAHX-*5 (32)	200 I	Opp	86	90	8-A-093(T) 8-A-032(P)		Furnished								
863XBAHX-*5	500 I	Opp	67	83			Furnished								

GEARED ADAPTERS

628XAHX-4AH	250 I	Eng			8-A-032		Furnished	626XAHX-4AH	250 I	Eng					Furnished
								630XAHX-4AH	250 I	Eng					Furnished
								645XAHX-4AH	250 I	Eng					Furnished

† I = Intermittent Torque Only - De-rate Torque Rating 30% for Continuous Duty.

C = Continuous or Intermittent Torque - No need to De-Rate Torque Rating.

IMPORTANT: Refer to the back of this transmission section and read all notes associated with this application page. Some notes may affect the proper PTO selection.

CAUTION: Do not use geared adapters with 442 A and C ratios.

(32) Input Gear Part No. 5-P-581

SPR-144

TREMEC/TTC/SPICER

CHELSEA®

PS86-10V (BM#301587)

LEFT SIDE ONLY

RIGHT SIDE ONLY

TRANSMISSION GEAR DATA:

L.S. 08-BOLT Opening Gear FORWARD of Centerline
45 Teeth - SPUR

PITCH LINE TO APERTURE FACE:

0.7300" (17.8550MM)

TRANSMISSION GEAR DATA:

R.S. 06-BOLT Opening Gear REAR of Centerline
45 Teeth - SPUR

PITCH LINE TO APERTURE FACE:

1.0750" (27.3050MM)

CAUTION: Application Approval Required for PTO Output Shaft Speeds Above 2500 RPM

PTO Model	Torq l / C †	Dir Rot	Engine %		Filler Block	Adapter Assy	Stud Kit	PTO Model	Torq l / C †	Dir Rot	Engine %		Filler Block	Adapter Assy	Stud Kit
			Fwd	Rev							Fwd	Rev			

ONE SPEED - TWO GEAR - MECHANICAL SHIFT

221XEAHX-*5	250 l	Opp	58			328481X	Furnished	221XCAHX-*4	250 l	Opp	51		7-A-062 7-A-032(31)	Furnished
489XAAHX-*5 (12)	250 l	Opp	44				Furnished	221XEAHX-*4	250 l	Opp	58			Furnished
489XCAHX-*5 (13)	250 l	Opp	57				Furnished	442XFAHX-*4 (2)	250 l	Opp	70			Furnished
489XFAHX-*5 (2)	250 l	Opp	70				Furnished	442XHAHX-*4 (15)	250 l	Opp	81			Furnished
489XHAHX-*5 (15)	250 l	Opp	81				Furnished	442XLAHX-*4 (1)	250 l	Opp	91			Furnished
489XLAHX-*5 (1)	250 l	Opp	91				Furnished	442XQAHX-*4 (1)	225 l	Opp	98			Furnished
489XQAHX-*5 (1)	225 l	Opp	98				Furnished	442XRAHX-*4 (1)	225 l	Opp	113			Furnished
489XRAHX-*5 (1)	225 l	Opp	113				Furnished	442XSAHX-*4 (1)	200 l	Opp	135			Furnished
489XSAHX-*5 (1)	200 l	Opp	135				Furnished	442XUAHX-*4 (1)	195 l	Opp	161			Furnished
489XUAHX-*5 (1)	195 l	Opp	161				Furnished	442XWAHX-*4 (1)	175 l	Opp	189			Furnished
489XWAHX-*5 (1)	175 l	Opp	189				Furnished	442XXAHX-*4 (1)	140 l	Opp	224			Furnished
489XXAHX-*5 (1)	140 l	Opp	224				Furnished	660XFAHX-*4 (10)	375 l	Opp	70			Furnished
680XFAHX-*5 (10)	375 l	Opp	70				Furnished	660XHAHX-*4 (15)	375 l	Opp	81			Furnished
680XHAHX-*5 (19)	375 l	Opp	81				Furnished	660XQAHX-*4 (11)	375 l	Opp	98			Furnished
680XQAHX-*5 (11)	375 l	Opp	98				Furnished	660XRAHX-*4 (18)	350 l	Opp	113			Furnished
680XRAHX-*5 (18)	350 l	Opp	113				Furnished	660XSAHX-*4 (14)	325 l	Opp	135			Furnished
680XSAHX-*5 (14)	325 l	Opp	135				Furnished							
823XTKTX-*3 (17)	350 l	Opp	142		8-A-165(30)		Furnished							
880XBAHX-*3 (3)	500 l	Opp	48				Furnished							
880XDAHX-*3 (4)	500 l	Opp	57				Furnished							
880XGAHX-*3 (9)	500 l	Opp	62				Furnished							
880XJAHX-*3 (5)	500 l	Opp	72				Furnished							
880XMAHX-*3 (6)	500 l	Opp	85				Furnished							
880XQAHX-*3 (16)	450 l	Opp	99				Furnished							
880XRAHX-*3 (7)	400 l	Opp	117				Furnished							
880XTAHX-*3 (8)	350 l	Opp	151				Furnished							

ONE SPEED - TWO GEAR POWERSHIFT (AIR OR HYDRAULIC)

282XBAJX-*5 (20)	300 C	Opp	48		8-A-032		Furnished							
282XCAJX-*5 (21)	300 C	Opp	58		8-A-032		Furnished							
282XDAJX-*5 (22)	300 C	Opp	69		8-A-032		Furnished							

Continued on Next Page

† I = Intermittent Torque Only - De-rate Torque Rating 30% for Continuous Duty.

C = Continuous or Intermittent Torque - No need to De-Rate Torque Rating.

IMPORTANT: Refer to the back of this transmission section and read all notes associated with this application page. Some notes may affect the proper PTO selection.

- | | | | | |
|----------------------------------|-----------------------------------|-----------------------------------|---------------------------------------|---------------------------------------|
| (1) Input Gear Part No. 5-P-1004 | (6) Input Gear Part No. 5-P-1103 | (11) Input Gear Part No. 5-P-1246 | (16) Input Gear Part No. 5-P-1385 | (21) Input Gear Part No. 5-P-1510-12X |
| (2) Input Gear Part No. 5-P-1077 | (7) Input Gear Part No. 5-P-1104 | (12) Input Gear Part No. 5-P-1280 | (17) Input Gear Part No. 5-P-1395 | (22) Input Gear Part No. 5-P-1510-13X |
| (3) Input Gear Part No. 5-P-1100 | (8) Input Gear Part No. 5-P-1105 | (13) Input Gear Part No. 5-P-1287 | (18) Input Gear Part No. 5-P-1441 | (30) Filler block furnished with PTO |
| (4) Input Gear Part No. 5-P-1101 | (9) Input Gear Part No. 5-P-1135 | (14) Input Gear Part No. 5-P-1322 | (19) Input Gear Part No. 5-P-1494 | (31) Furnished, but not required |
| (5) Input Gear Part No. 5-P-1102 | (10) Input Gear Part No. 5-P-1242 | (15) Input Gear Part No. 5-P-1364 | (20) Input Gear Part No. 5-P-1510-11X | |

Tremec/TTC/Spicer

CHELSEA®

TREMEC/TTC/SPICER

SPR-144

PS86-10V (BM#301587)

LEFT SIDE ONLY

RIGHT SIDE ONLY

TRANSMISSION GEAR DATA:

L.S. 08-BOLT Opening Gear FORWARD of Centerline
45 Teeth - SPUR

PITCH LINE TO APERTURE FACE:

0.7300" (17.8550MM)

TRANSMISSION GEAR DATA:

R.S. 06-BOLT Opening Gear REAR of Centerline
45 Teeth - SPUR

PITCH LINE TO APERTURE FACE:

1.0750" (27.3050MM)

CAUTION: Application Approval Required for PTO Output Shaft Speeds Above 2500 RPM

PTO Model	Torq I / C †	Dir Rot	Engine %		Filler Block	Adapter Assy	Stud Kit	PTO Model	Torq I / C †	Dir Rot	Engine %		Filler Block	Adapter Assy	Stud Kit
			Fwd	Rev							Fwd	Rev			
ONE SPEED - TWO GEAR POWERSHIFT (AIR OR HYDRAULIC)															
282XGAJX-*5 (23)	300 C	Opp	82		8-A-032		Furnished								
282XKAJX-*5 (24)	300 C	Opp	92		8-A-032		Furnished								
282XMAJX-*5 (25)	300 C	Opp	103		8-A-032		Furnished								
282XPAJX-*5 (26)	300 C	Opp	115		8-A-032		Furnished								
282XSAJX-*5 (27)	300 C	Opp	129		8-A-032		Furnished								
282XTAJX-*5 (28)	300 C	Opp	144		8-A-032		Furnished								
ONE SPEED - TWO GEAR - POWERSHIFT (AIR)															
885XBAHX-*3 (3)	500 I	Opp	48				Furnished								
885XGAHX-*3 (9)	500 I	Opp	62				Furnished								
885XJAHX-*3 (5)	500 I	Opp	72				Furnished								
885XMAHX-*3 (6)	500 I	Opp	85				Furnished								
ONE SPEED - FORWARD & REVERSE															
348XFAHX-*4 (29)	200 I	Opp	61	64			Furnished	340XFAHX-*4 (29)	200 I	Opp	61	64	7-A-140(31)		Furnished
863XBAHX-*5	500 I	Opp	48	59			Furnished								

† I = Intermittent Torque Only - De-rate Torque Rating 30% for Continuous Duty.

C = Continuous or Intermittent Torque - No need to De-Rate Torque Rating.

IMPORTANT: Refer to the back of this transmission section and read all notes associated with this application page. Some notes may affect the proper PTO selection.

(3) Input Gear Part No. 5-P-1100 (24) Input Gear Part No. 5-P-1510-15X (29) Input Gear Part No. 5-P-581
 (5) Input Gear Part No. 5-P-1102 (25) Input Gear Part No. 5-P-1510-16X (31) Furnished, but not required
 (6) Input Gear Part No. 5-P-1103 (26) Input Gear Part No. 5-P-1510-17X
 (9) Input Gear Part No. 5-P-1135 (27) Input Gear Part No. 5-P-1510-18X
 (23) Input Gear Part No. 5-P-1510-14X (28) Input Gear Part No. 5-P-1510-19X

TTC-150

TREMEC/TTC/SPICER



TDET0880 (Same as TR-4050, Dodge Mexico)
TDET1015 (Same as TR-4050 w/ special ratio-Ford Mexico)
TDET1361 (Same as TR-4050, Chev/GMC)
TDET1664 (Same as TR-4050, Ford Mexico)
TR-4050 (Transmission made in Mexico)

RIGHT SIDE ONLY

TRANSMISSION GEAR DATA:
L.S. 06-BOLT Opening Gear FORWARD of Centerline
32 Teeth - R.H. - HELIX
PITCH LINE TO APERTURE FACE:
1.1400" (28.9342MM)

CAUTION: Application Approval Required for PTO Output Shaft Speeds Above 2500 RPM

PTO Model	Torq	Dir Rot	Engine %		Filler Block	Adapter Assy	Stud Kit	PTO Model	Torq	Dir Rot	Engine %		Filler Block	Adapter Assy	Stud Kit
	I / C †		Fwd	Rev					I / C †		Fwd	Rev			

ONE SPEED - TWO GEAR - MECHANICAL SHIFT

442XLKNX-*3 (1)	250 I	Opp	49												Furnished
442XQKNX-*3 (1)	225 I	Opp	53												Furnished
442XRKNX-*3 (1)	225 I	Opp	61												Furnished
442XSKNX-*3 (1)	200 I	Opp	73												Furnished
442XUKNX-*3 (1)	195 I	Opp	87												Furnished
442XWKNX-*3 (1)	175 I	Opp	102												Furnished
442XXKNX-*3 (1)	140 I	Opp	121												Furnished

ONE SPEED - TWO GEAR POWERSHIFT (AIR OR HYDRAULIC)

272ZAKNX-*3 (2)	300 C	Opp	24												Furnished
272ZBKNX-*3 (3)	300 C	Opp	29												Furnished
272ZCKNX-*3 (4)	300 C	Opp	35												Furnished
272ZDKNX-*3 (5)	300 C	Opp	42												Furnished
272ZGKNX-*3 (6)	279 C	Opp	50												Furnished
272ZKKNX-*3 (7)	249 C	Opp	56												Furnished
272ZMKNX-*3 (8)	223 C	Opp	63												Furnished
272ZPKNX-*3 (9)	200 C	Opp	71												Furnished
272ZSKNX-*3 (10)	178 C	Opp	79												Furnished

GEARED ADAPTERS

626XKNX-3KP	250 I	Eng													7170-4X
630XKNX-3KP	250 I	Eng													7170-4X
645XKNX-3KP	250 I	Eng													7170-4X

† I = Intermittent Torque Only - De-rate Torque Rating 30% for Continuous Duty.

C = Continuous or Intermittent Torque - No need to De-Rate Torque Rating.

IMPORTANT: Refer to the back of this transmission section and read all notes associated with this application page. Some notes may affect the proper PTO selection.

- (1) Input Gear Part No. 5-P-1383
- (2) Input Gear Part No. 5-P-1556-1X
- (3) Input Gear Part No. 5-P-1556-2X
- (4) Input Gear Part No. 5-P-1556-3X
- (5) Input Gear Part No. 5-P-1556-4X
- (6) Input Gear Part No. 5-P-1556-5X
- (7) Input Gear Part No. 5-P-1556-6X
- (8) Input Gear Part No. 5-P-1556-7X
- (9) Input Gear Part No. 5-P-1556-8X
- (10) Input Gear Part No. 5-P-1556-9X

Tremec/TTC/Spicer



October 2022
5.14.14

Parker Hannifin Corporation
Chelsea Products Division
Olive Branch, MS 38654 USA

PSDO165-18A (Released for Mexico Market)
PSDO185-18A (Released for Mexico Market)
PSDO205-18A (Released for Mexico Market)

BOTTOM SIDE ONLY

RIGHT SIDE ONLY

TRANSMISSION GEAR DATA:

BOT 08-BOLT Opening Gear FORWARD of Centerline
52 Teeth - SPUR

PITCH LINE TO APERTURE FACE:

0.9280" (23.5700MM)

TRANSMISSION GEAR DATA:

R.S. 06-BOLT Opening Gear REAR of Centerline
52 Teeth - SPUR

PITCH LINE TO APERTURE FACE:

1.2280" (31.1900MM)

CAUTION: Application Approval Required for PTO Output Shaft Speeds Above 2500 RPM

PTO Model	Torq I / C †	Dir Rot	Engine %		Filler Block	Adapter Assy	Stud Kit	PTO Model	Torq I / C †	Dir Rot	Engine %		Filler Block	Adapter Assy	Stud Kit
			Fwd	Rev							Fwd	Rev			

ONE SPEED - TWO GEAR - MECHANICAL SHIFT

221ZCAHX-*3 (28)	250 I	Opp	68		8-A-032(T)	310778X	Furnished	221ZCAHX-*4 (28)	250 I	Opp	68		7-A-093(T)		328170-96X
221ZEAHX-*3 (27)	250 I	Opp	75			310778X	Furnished	221ZEAHX-*4 (27)	250 I	Opp	75		7-A-062(T)		328170-96X
489ZAAHX-*5 (12)	250 I	Opp	59		8-A-032(P)		Furnished	442LAAHX-*4 (12)	250 I	Opp	59		7-A-062(P)		328170-94X
489ZCAHX-*5 (13)	250 I	Opp	76		8-A-032(P)		Furnished	442LCAHX-*4 (13)	250 I	Opp	76		7-A-062(P)		328170-94X
489ZFAHX-*5 (2)	250 I	Opp	94		8-A-032(P)		Furnished	442LFAHX-*4 (2)	250 I	Opp	94		7-A-062(P)		328170-94X
489ZHAHX-*5 (15)	250 I	Opp	108		8-A-032(P)		Furnished	442LHAHX-*4 (15)	250 I	Opp	108		7-A-062(P)		328170-94X
489ZLAHX-*5 (1)	250 I	Opp	122		8-A-032(P)		Furnished	442LLAHX-*4 (1)	250 I	Opp	121		7-A-062(P)		328170-94X
489ZQAHX-*5 (1)	225 I	Opp	131		8-A-032(P)		Furnished	442LQAHX-*4 (1)	225 I	Opp	131		7-A-062(P)		328170-94X
489ZRAHX-*5 (1)	225 I	Opp	152		8-A-032(P)		Furnished	442LRAHX-*4 (1)	225 I	Opp	152		7-A-062(P)		328170-94X
489ZSAHX-*5 (1)	200 I	Opp	181		8-A-032(P)		Furnished	442LSAHX-*4 (1)	200 I	Opp	181		7-A-062(P)		328170-94X
489ZUAHX-*5 (1)	195 I	Opp	215		8-A-032(P)		Furnished	442LUAHX-*4 (1)	195 I	Opp	216		7-A-062(P)		328170-94X
489ZWAHX-*5 (1)	175 I	Opp	254		8-A-032(P)		Furnished	442LWAHX-*4 (1)	175 I	Opp	254		7-A-062(P)		328170-94X
489ZAXHX-*5 (1)	140 I	Opp	300		8-A-032(P)		Furnished	442LAXHX-*4 (1)	140 I	Opp	301		7-A-062(P)		328170-94X
880ZBAHX-*3 (3)	500 I	Opp	64		8-A-248(P)		328170-179X	660LFAHX-*4 (10)	375 I	Opp	94		7-A-062(P)		328170-94X
					8-A-500										
880ZDAHX-*3 (4)	500 I	Opp	76		8-A-245(P)		328170-179X	660LHAHX-*4 (15)	375 I	Opp	108		7-A-062(P)		328170-94X
					8-A-500										
880ZGAHX-*3 (9)	500 I	Opp	85		8-A-248(P)		328170-179X	660LQAHX-*4 (11)	375 I	Opp	131		7-A-062(P)		328170-94X
					8-A-500										
880ZJAHX-*3 (5)	500 I	Opp	97		8-A-248(P)		328170-179X	660LRAHX-*4 (17)	350 I	Opp	152		7-A-062(P)		328170-94X
					8-A-500										
880ZMAHX-*3 (6)	500 I	Opp	113		8-A-248(P)		328170-179X	660LSAHX-*4 (14)	325 I	Opp	181		7-A-062(P)		328170-94X
					8-A-500										
880ZQAHX-*3 (16)	450 I	Opp	134		8-A-248(P)		328170-179X								
					8-A-500										
880ZRAHX-*3 (7)	400 I	Opp	158		8-A-248(P)		328170-179X								
					8-A-500										
880ZTAHX-*3 (8)	350 I	Opp	203		8-A-248(P)		328170-179X								
					8-A-500										

ONE SPEED - TWO GEAR POWERSHIFT (AIR OR HYDRAULIC)

Continued on Next Page

† I = Intermittent Torque Only - De-rate Torque Rating 30% for Continuous Duty.

C = Continuous or Intermittent Torque - No need to De-Rate Torque Rating.

IMPORTANT: Refer to the back of this transmission section and read all notes associated with this application page. Some notes may affect the proper PTO selection.

- (1) Input Gear Part No. 5-P-1004
- (2) Input Gear Part No. 5-P-1077
- (3) Input Gear Part No. 5-P-1100
- (4) Input Gear Part No. 5-P-1101
- (5) Input Gear Part No. 5-P-1102

- (6) Input Gear Part No. 5-P-1103
- (7) Input Gear Part No. 5-P-1104
- (8) Input Gear Part No. 5-P-1105
- (9) Input Gear Part No. 5-P-1135
- (10) Input Gear Part No. 5-P-1242

- (11) Input Gear Part No. 5-P-1246
- (12) Input Gear Part No. 5-P-1280
- (13) Input Gear Part No. 5-P-1287
- (14) Input Gear Part No. 5-P-1322
- (15) Input Gear Part No. 5-P-1364

- (16) Input Gear Part No. 5-P-1385
- (17) Input Gear Part No. 5-P-1441
- (27) Input Gear Part No. 5-P-202
- (28) Input Gear Part No. 5-P-319

TTC-151

TREMEC/TTC/SPICER

CHELSEA®

PSDO165-18A (Released for Mexico Market)
PSDO185-18A (Released for Mexico Market)
PSDO205-18A (Released for Mexico Market)

BOTTOM SIDE ONLY

RIGHT SIDE ONLY

TRANSMISSION GEAR DATA:

BOT 08-BOLT Opening Gear FORWARD of Centerline
52 Teeth - SPUR

PITCH LINE TO APERTURE FACE:

0.9280" (23.5700MM)

TRANSMISSION GEAR DATA:

R.S. 06-BOLT Opening Gear REAR of Centerline
52 Teeth - SPUR

PITCH LINE TO APERTURE FACE:

1.2280" (31.1900MM)

CAUTION: Application Approval Required for PTO Output Shaft Speeds Above 2500 RPM

PTO Model	Torq I / C †	Dir Rot	Engine %		Filler Block	Adapter Assy	Stud Kit	PTO Model	Torq I / C †	Dir Rot	Engine %		Filler Block	Adapter Assy	Stud Kit
			Fwd	Rev							Fwd	Rev			

ONE SPEED - TWO GEAR POWERSHIFT (AIR OR HYDRAULIC)

282XBAJX-*5 (18)	300 C	Opp	64		8-A-032		Furnished								
282XCAJX-*5 (19)	300 C	Opp	78		8-A-032		Furnished								
282XDAJX-*5 (20)	300 C	Opp	93		8-A-032		Furnished								
282XGAJX-*5 (21)	300 C	Opp	111		8-A-032		Furnished								
282XKAJX-*5 (22)	300 C	Opp	124		8-A-032		Furnished								
282XMAJX-*5 (23)	300 C	Opp	139		8-A-032		Furnished								
282XPAJX-*5 (24)	300 C	Opp	155		8-A-032		Furnished								
282XSAJX-*5 (25)	289 C	Opp	173		8-A-032		Furnished								
282XTAJX-*5 (26)	258 C	Opp	194		8-A-032		Furnished								

ONE SPEED - FORWARD & REVERSE

348ZFAHX-*5 (29)	200 I	Opp	82	86	8-A-032		Furnished	340ZFAHX-*4 (29)	200 I	Opp	82	86	7-A-062(P)		Furnished
------------------	-------	-----	----	----	---------	--	-----------	------------------	-------	-----	----	----	------------	--	-----------

GEARED ADAPTERS

628ZAHX-3XX (1)	250 I	Eng			8-A-032(T)		Furnished	626KAHX-4XX (1)	250 I	Eng			7-A-062(T)		328170-94X
								630KAHX-4XX (1)	250 I	Eng			7-A-062(T)		328170-94X
								645KAHX-4XX (1)	250 I	Eng			7-A-062(T)		328170-94X

† I = Intermittent Torque Only - De-rate Torque Rating 30% for Continuous Duty.

C = Continuous or Intermittent Torque - No need to De-Rate Torque Rating.

IMPORTANT: Refer to the back of this transmission section and read all notes associated with this application page. Some notes may affect the proper PTO selection.

(1) Input Gear Part No. 5-P-1004 (22) Input Gear Part No. 5-P-1510-15X (29) Input Gear Part No. 5-P-581
 (18) Input Gear Part No. 5-P-1510-11X (23) Input Gear Part No. 5-P-1510-16X
 (19) Input Gear Part No. 5-P-1510-12X (24) Input Gear Part No. 5-P-1510-17X
 (20) Input Gear Part No. 5-P-1510-13X (25) Input Gear Part No. 5-P-1510-18X
 (21) Input Gear Part No. 5-P-1510-14X (26) Input Gear Part No. 5-P-1510-19X

Tremec/TTC/Spicer Notes

SPR-104

1. Speeds shown are with transmission in high range. For speeds in low range, multiply speed shown by .84.
 2. The AK & XK output flanges can not be used with the A & C ratios on the 489 Series PTOs due to mounting stud interference. Use a RA or RB rotatable flange for the XK and the RA for the AK flange.
 3. 272/282 Series - Must be used as an AIR Shift PTO. Order Air Shift Options Only
-

SPR-105

1. PTO speeds shown are with transmission in low range - for speeds in high range multiply speeds shown by 1.28.
 2. 272/282 Series - Must be used as an AIR Shift PTO. Order Air Shift Options Only
-

SPR-140

1. The AK & XK output flanges can not be used with the A & C ratios on the 489 Series PTOs due to mounting stud interference. Use a RA or RB rotatable flange for the XK and the RA for the AK flange.
 2. 272/282 Series - Must be used as an AIR Shift PTO. Order Air Shift Options Only
-

SPR-144

1. The AK & XK output flanges can not be used with the A & C ratios on the 489 Series PTOs due to mounting stud interference. Use a RA or RB rotatable flange for the XK and the RA for the AK flange.
 2. 272/282 Series - Must be used as an AIR Shift PTO. Order Air Shift Options Only
-

TTC-150

1. 272/282 Series - Must be used as an AIR Shift PTO. Order Air Shift Options Only
-

TTC-151

1. The PTO output speeds shown are with the transmission in High Range, for PTO output speeds with the transmission in low range, multiply speeds shown by .82
2. 272/282 Series - Must be used as an AIR Shift PTO. Order Air Shift Options Only



VOLVO

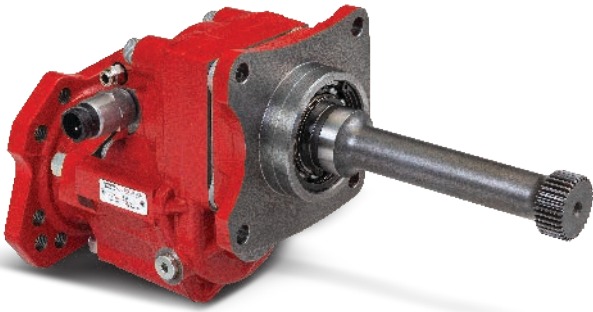

Parker | Chelsea

ENGINEERING YOUR SUCCESS.

**WARNING — User Responsibility**

FAILURE OR IMPROPER SELECTION OR IMPROPER USE OF THE PRODUCTS DESCRIBED HEREIN OR RELATED ITEMS CAN CAUSE DEATH, PERSONAL INJURY AND PROPERTY DAMAGE.

This document and other information from Parker Hannifin Corporation, its subsidiaries and authorized distributors provide product or system options for further investigation by users having technical expertise.

The user, through its own analysis and testing, is solely responsible for making the final selection of the system and components and assuring that all performance, endurance, maintenance, safety and warning requirements of the application are met. The user must analyze all aspects of the application, follow applicable industry standards, and follow the information concerning the product in the current product catalog and in any other materials provided from Parker or its subsidiaries or authorized distributors.

To the extent that Parker or its subsidiaries or authorized distributors provide component or system options based upon data or specifications provided by the user, the user is responsible for determining that such data and specifications are suitable and sufficient for all applications and reasonably foreseeable uses of the components or systems.

Offer of Sale

The items described in this document are hereby offered for sale by Parker Hannifin Corporation, its subsidiaries or its authorized distributors. This offer and its acceptance are governed by the provisions stated in the "Offer of Sale".



WARNING: This product can expose you to chemicals including Lead and Lead Compounds, and Di(2-ethylhexyl)phthalate (DEHP) which are known to the State of California to cause cancer and birth defects or other reproductive harm. For more information go to www.P65Warnings.ca.gov

© Copyright 2022, Parker Hannifin Corporation, All Rights Reserved

Transmission Make and Model	PTO	Number	Teeth in
	Appl.	Forward	PTO
	Number	Speeds	Driver
AT2412 (I-Shift) High Split Ratio	VLV-10H	12	CS
AT2412 (I-Shift) Low Ratio	VLV-10	12	CS
AT2512 (I-Shift) High Split Ratio	VLV-10H	12	CS
AT2512 (I-Shift) Low Ratio	VLV-10	12	CS
AT2512C (I-Shift) High Split Ratio	VLV-10H	12	CS
AT2512C (I-Shift) Low Ratio	VLV-10	12	CS
AT2612 (I-Shift) High Split Ratio	VLV-10H	12	CS
AT2612 (I-Shift) Low Ratio	VLV-10	12	CS
AT2612D (I-Shift) High Split Ratio	VLV-10H	12	CS
AT2612D (I-Shift) Low Ratio	VLV-10	12	CS
AT2812 (I-Shift) High Split Ratio	VLV-10H	12	CS
AT2812 (I-Shift) Low Ratio	VLV-10	12	CS
AT2812C (I-Shift) High Split Ratio	VLV-10H	12	CS
AT2812C (I-Shift) Low Ratio	VLV-10	12	CS
ATO2512 (I-Shift) High Split Range	VLV-13H	12	CS
ATO2512 (I-Shift) Low Ratio	VLV-13	12	CS
ATO2512C (I-Shift) High Split Range	VLV-13H	12	CS
ATO2512C (I-Shift) Low Ratio	VLV-13	12	CS
ATO2612 (I-Shift) High Split Range	VLV-13H	12	CS
ATO2612 (I-Shift) Low Ratio	VLV-13	12	CS
ATO2612C (I-Shift) High Split Range	VLV-13H	12	CS
ATO2612C (I-Shift) Low Ratio	VLV-13	12	CS
ATO2612D (I-Shift) High Split Range	VLV-13H	12	CS
ATO2612D (I-Shift) Low Ratio	VLV-13	12	CS
ATO2613F (I-Shift) High Split Range	VLV-13H	12	CS
ATO2613F (I-Shift) Low Ratio	VLV-13	12	CS
ATO3112 (I-Shift) High Split Range	VLV-13H	12	CS
ATO3112 (I-Shift) Low Ratio	VLV-13	12	CS
ATO3112C (I-Shift) High Split Range	VLV-13H	12	CS
ATO3112C (I-Shift) Low Ratio	VLV-13	12	CS
ATO3112D (I-Shift) High Split Range	VLV-13H	12	CS
ATO3112D (I-Shift) Low Ratio	VLV-13	12	CS
V2412AT (I-Shift) High Split Ratio	VLV-10H	12	CS
V2412AT (I-Shift) Low Ratio	VLV-10	12	CS
V2512AT (I-Shift) High Split Ratio	VLV-10H	12	CS



IMPORTANT: See Safety Information
in Section 1 of the Chelsea Applications
catalog HY25-3000/US

Transmission PTO Driver & Apertures (Viewed from Rear of Transmission)
L-Left Side R-Right Side B-Bottom Side T-Top Side CS-Countershaft
For transmissions not listed, contact your authorized Chelsea Distributor.

VOLVO TRANSMISSION INDEX

Transmission Make and Model	PTO Appl. Number	Number Forward Speeds	Teeth in PTO Driver
V2512AT (I-Shift) Low Ratio	VLV-10	12	CS
V2812AT (I-Shift) High Split Ratio	VLV-10H	12	CS
V2812AT (I-Shift) Low Ratio	VLV-10	12	CS
VO2512AT (I-Shift) High Split Range	VLV-13H	12	CS
VO2512AT (I-Shift) Low Ratio	VLV-13	12	CS
VO3112AT (I-Shift) High Split Range	VLV-13H	12	CS
VO3112AT (I-Shift) Low Ratio	VLV-13	12	CS

Volvo



IMPORTANT: See Safety Information
in Section 1 of the Chelsea Applications
catalog HY25-3000/US

Transmission PTO Driver & Apertures (Viewed from Rear of Transmission)
L-Left Side R-Right Side B-Bottom Side T-Top Side CS-Countershaft
For transmissions not listed, contact your authorized Chelsea Distributor.

CHELSEA®

VOLVO

VLV-10

AT2412 (I-Shift) Low Ratio	V2512AT (I-Shift) Low Ratio
AT2512 (I-Shift) Low Ratio	V2812AT (I-Shift) Low Ratio
AT2512C (I-Shift) Low Ratio	
AT2612 (I-Shift) Low Ratio	
AT2612D (I-Shift) Low Ratio	
AT2812 (I-Shift) Low Ratio	
AT2812C (I-Shift) Low Ratio	
V2412AT (I-Shift) Low Ratio	

REAR SIDE ONLY

TRANSMISSION GEAR DATA:

REAR 04-BOLT Opening NON-STANDARD of Centerline
0 Teeth

PITCH LINE TO APERTURE FACE:

0.0000" (0.0000MM)

CAUTION: Application Approval Required for PTO Output Shaft Speeds Above 2500 RPM

PTO Model	Torq	Dir Rot	Engine %		Filler Block	Adapter Assy	Stud Kit	PTO Model	Torq	Dir Rot	Engine %		Filler Block	Adapter Assy	Stud Kit
	I / C †		Fwd	Rev					I / C †		Fwd	Rev			

REAR MOUNT - MECHANICAL SHIFT (12 SPEED TRANSMISSIONS)

512XRASW-V-XY	258 C	Opp	70				Furnished
512XRASX-V-XK	258 C	Opp	70				Furnished
512XRASX-V-XV	258 C	Opp	70				Furnished
524XTASX-V-*	300 C	Eng	93				Furnished
524XVASX-V-*	258 C	Eng	126				Furnished

† I = Intermittent Torque Only - De-rate Torque Rating 30% for Continuous Duty.

C = Continuous or Intermittent Torque - No need to De-Rate Torque Rating.

IMPORTANT: Refer to the back of this transmission section and read all notes associated with this application page. Some notes may affect the proper PTO selection.

Volvo

VLV-10H

VOLVO

CHELSEA®

AT2412 (I-Shift) High Split Ratio	V2512AT (I-Shift) High Split Ratio
AT2512 (I-Shift) High Split Ratio	V2612AT (I-Shift) High Split Ratio
AT2512C (I-Shift) High Split Ratio	
AT2612 (I-Shift) High Split Ratio	
AT2612D (I-Shift) High Split Ratio	
AT2812 (I-Shift) High Split Ratio	
AT2812C (I-Shift) High Split Ratio	
V2412AT (I-Shift) High Split Ratio	

REAR SIDE ONLY

TRANSMISSION GEAR DATA:
 REAR 04-BOLT Opening NON-STANDARD of Centerline
 0 Teeth
PITCH LINE TO APERTURE FACE:
 0.0000" (0.0000MM)

CAUTION: Application Approval Required for PTO Output Shaft Speeds Above 2500 RPM

PTO Model	Torq	Dir Rot	Engine %		Filler Block	Adapter Assy	Stud Kit	PTO Model	Torq	Dir Rot	Engine %		Filler Block	Adapter Assy	Stud Kit
	I / C †		Fwd	Rev					I / C †		Fwd	Rev			

REAR MOUNT - MECHANICAL SHIFT (12 SPEED TRANSMISSIONS)

512XRASW-V-XY	258 C	Opp	90				Furnished
512XRASX-V-XK	258 C	Opp	90				Furnished
512XRASX-V-XV	258 C	Opp	90				Furnished
524XTASX-V-*	300 C	Eng	119				Furnished
524XVASX-V-*	258 C	Eng	161				Furnished

† I = Intermittent Torque Only - De-rate Torque Rating 30% for Continuous Duty.

C = Continuous or Intermittent Torque - No need to De-Rate Torque Rating.

IMPORTANT: Refer to the back of this transmission section and read all notes associated with this application page. Some notes may affect the proper PTO selection.

Volvo

ATO2512 (I-Shift) Low Ratio ATO2512C (I-Shift) Low Ratio ATO2612 (I-Shift) Low Ratio ATO2612C (I-Shift) Low Ratio ATO2612D (I-Shift) Low Ratio ATO2613F (I-Shift) Low Ratio ATO3112 (I-Shift) Low Ratio ATO3112C (I-Shift) Low Ratio	ATO3112D (I-Shift) Low Ratio VO2512AT (I-Shift) Low Ratio VO3112AT (I-Shift) Low Ratio
---	--

REAR SIDE ONLY

TRANSMISSION GEAR DATA:

REAR 04-BOLT Opening NON-STANDARD of Centerline
0 Teeth

PITCH LINE TO APERTURE FACE:

0.0000" (0.0000MM)

CAUTION: Application Approval Required for PTO Output Shaft Speeds Above 2500 RPM

PTO Model	Torq	Dir Rot	Engine %		Filler Block	Adapter Assy	Stud Kit	PTO Model	Torq	Dir Rot	Engine %		Filler Block	Adapter Assy	Stud Kit
	I / C †		Fwd	Rev					I / C †		Fwd	Rev			

REAR MOUNT - MECHANICAL SHIFT (12 SPEED TRANSMISSIONS)

512XRASW-V-XY	258 C	Opp	90				Furnished
512XRASX-V-XK	258 C	Opp	90				Furnished
512XRASX-V-XV	258 C	Opp	90				Furnished
511XRASW-V-*	590 C	Opp	90				Furnished
524XTASX-V-*	300 C	Eng	120				Furnished
524XVASX-V-*	258 C	Eng	162				Furnished

† I = Intermittent Torque Only - De-rate Torque Rating 30% for Continuous Duty.

C = Continuous or Intermittent Torque - No need to De-Rate Torque Rating.

IMPORTANT: Refer to the back of this transmission section and read all notes associated with this application page. Some notes may affect the proper PTO selection.

VLV-13H

VOLVO

CHELSEA®

ATO2512 (I-Shift) High Split Range	ATO3112D (I-Shift) High Split Range
ATO2512C (I-Shift) High Split Range	VO2512AT (I-Shift) High Split Range
ATO2612 (I-Shift) High Split Range	VO3112AT (I-Shift) High Split Range
ATO2612C (I-Shift) High Split Range	
ATO2612D (I-Shift) High Split Range	
ATO2613F (I-Shift) High Split Range	
ATO3112 (I-Shift) High Split Range	
ATO3112C (I-Shift) High Split Range	

REAR SIDE ONLY

TRANSMISSION GEAR DATA:
 REAR 04-BOLT Opening NON-STANDARD of Centerline
 0 Teeth
PITCH LINE TO APERTURE FACE:
 0.0000" (0.0000MM)

CAUTION: Application Approval Required for PTO Output Shaft Speeds Above 2500 RPM

PTO Model	Torq	Dir Rot	Engine %		Filler Block	Adapter Assy	Stud Kit	PTO Model	Torq	Dir Rot	Engine %		Filler Block	Adapter Assy	Stud Kit
	I / C †		Fwd	Rev					I / C †		Fwd	Rev			

REAR MOUNT - MECHANICAL SHIFT (12 SPEED TRANSMISSIONS)

512XRASW-V-XY	258 C	Opp	115				Furnished
512XRASX-V-XK	258 C	Opp	115				Furnished
512XRASX-V-XV	258 C	Opp	115				Furnished
524XTASX-V-*	300 C	Eng	154				Furnished
524XVASX-V-*	258 C	Eng	207				Furnished

† I = Intermittent Torque Only - De-rate Torque Rating 30% for Continuous Duty.

C = Continuous or Intermittent Torque - No need to De-Rate Torque Rating.

IMPORTANT: Refer to the back of this transmission section and read all notes associated with this application page. Some notes may affect the proper PTO selection.

Volvo

Volvo Notes

VLV-10

1. Connection to Volvo system required for Volvo I-Shift or Mack M-Drive, the vehicle needs to be ordered with PTO prep package. Vehicle ECU must be programmed by dealer for PTO operation.
 2. PTO must be ordered with the V shift option and use the OE factory supplied in dash PTO switch.
 3. 511/523 Rear Mounts - The adapter 329735X is furnished with the PTO
 4. 524 Rear Mount - The adapter 329980X is furnished with the PTO
-

VLV-10H

1. Connection to Volvo system required for Volvo I-Shift or Mack M-Drive, the vehicle needs to be ordered with PTO prep package. Vehicle ECU must be programmed by dealer for PTO operation.
 2. PTO must be ordered with the V shift option and use the OE factory supplied in dash PTO switch.
 3. 511/523 Rear Mounts - The adapter 329735X is furnished with the PTO
 4. 524 Rear Mount - The adapter 329980X is furnished with the PTO
-

VLV-13

1. Connection to Volvo system required for Volvo I-Shift or Mack M-Drive, the vehicle needs to be ordered with PTO prep package. Vehicle ECU must be programmed by dealer for PTO operation.
 2. PTO must be ordered with the V shift option and use the OE factory supplied in dash PTO switch.
 3. 511/523 Rear Mounts - The adapter 329735X is furnished with the PTO
 4. 524 Rear Mount - The adapter 329980X is furnished with the PTO
-

VLV-13H

1. Connection to Volvo system required for Volvo I-Shift or Mack M-Drive, the vehicle needs to be ordered with PTO prep package. Vehicle ECU must be programmed by dealer for PTO operation.
 2. PTO must be ordered with the V shift option and use the OE factory supplied in dash PTO switch.
 3. 511/523 Rear Mounts - The adapter 329735X is furnished with the PTO
 4. 524 Rear Mount - The adapter 329980X is furnished with the PTO
-



ZF

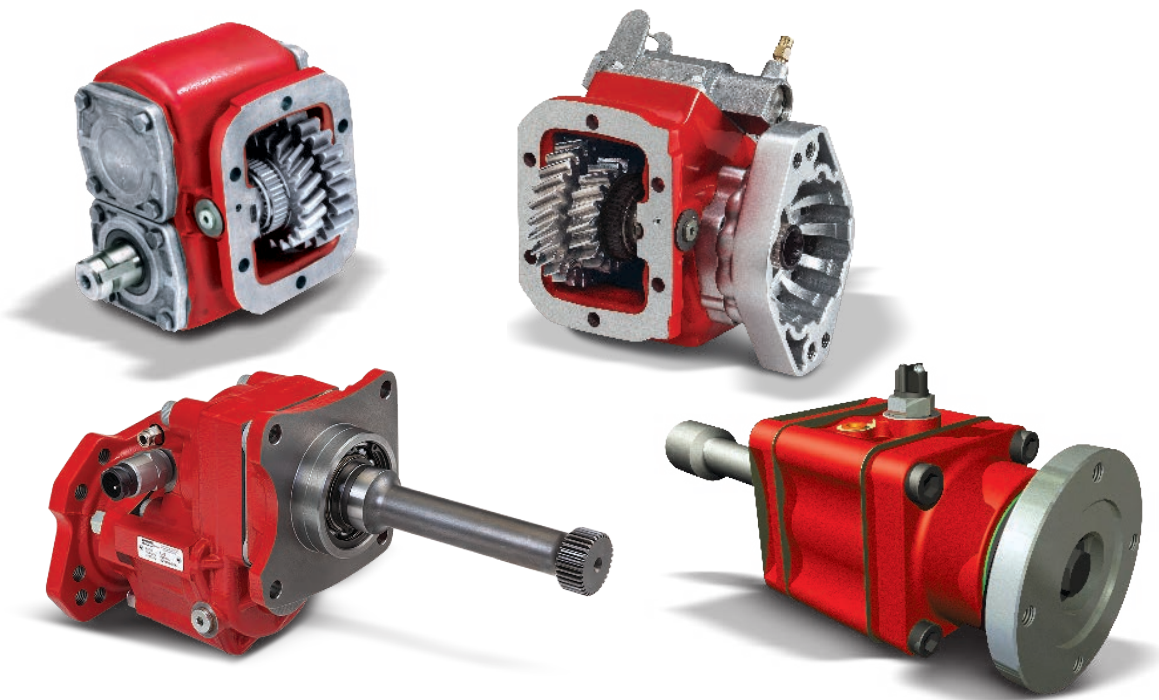

Parker | Chelsea

ENGINEERING YOUR SUCCESS.



WARNING — User Responsibility

FAILURE OR IMPROPER SELECTION OR IMPROPER USE OF THE PRODUCTS DESCRIBED HEREIN OR RELATED ITEMS CAN CAUSE DEATH, PERSONAL INJURY AND PROPERTY DAMAGE.

This document and other information from Parker Hannifin Corporation, its subsidiaries and authorized distributors provide product or system options for further investigation by users having technical expertise.

The user, through its own analysis and testing, is solely responsible for making the final selection of the system and components and assuring that all performance, endurance, maintenance, safety and warning requirements of the application are met. The user must analyze all aspects of the application, follow applicable industry standards, and follow the information concerning the product in the current product catalog and in any other materials provided from Parker or its subsidiaries or authorized distributors.

To the extent that Parker or its subsidiaries or authorized distributors provide component or system options based upon data or specifications provided by the user, the user is responsible for determining that such data and specifications are suitable and sufficient for all applications and reasonably foreseeable uses of the components or systems.

Offer of Sale

The items described in this document are hereby offered for sale by Parker Hannifin Corporation, its subsidiaries or its authorized distributors. This offer and its acceptance are governed by the provisions stated in the "Offer of Sale".



WARNING: This product can expose you to chemicals including Lead and Lead Compounds, and Di(2-ethylhexyl)phthalate (DEHP) which are known to the State of California to cause cancer and birth defects or other reproductive harm. For more information go to www.P65Warnings.ca.gov

© Copyright 2022, Parker Hannifin Corporation, All Rights Reserved

Transmission Make and Model	PTO Appl. Number	Number Forward Speeds	Teeth in PTO Driver
12AS-1630TD (AS-Tronic)	ZF-66	12	CS
12AS-1930TD (AS-Tronic)	ZF-66	12	CS
12AS-1930TO (AS-Tronic)	ZF-64	12	CS
12AS-2130TD (AS-Tronic)	ZF-66	12	CS
12AS-2130TO (AS-Tronic)	ZF-64	12	CS
12AS-2140TD (AS-Tronic)	ZF-66	12	CS
12AS-2301 (AS-Tronic - 12.33/0.78 Ratio)	ZF-64	12	CS
12AS-2301 (AS-Tronic - 15.86/1.0 Ratio)	ZF-66	12	CS
12AS-2330TD (AS-Tronic)	ZF-66	12	CS
12AS-2330TO (AS-Tronic)	ZF-64	12	CS
12AS-2340TD (AS-Tronic)	ZF-66	12	CS
12AS-2530TD (AS-Tronic)	ZF-66	12	CS
12AS-2530TD (AS-Tronic)	ZF-64	12	CS
12AS-2540TD (AS-Tronic)	ZF-66	12	CS
12AS-2540TO (AS-Tronic)	ZF-64	12	CS
12AS-2740TO (AS-Tronic)	ZF-64	12	CS
12AS-2940TO (AS-Tronic)	ZF-64	12	CS
16AS-2601 (AS-Tronic 14.12/0.83 Ratio)	ZF-65	16	CS
16AS-2601 (AS-Tronic - 17.03/1.0 Ratio)	ZF-67	16	CS
16AS-2630TO (AS-Tronic)	ZF-65	16	CS
6A-S800TO	ZF-22	6	CS
6S-800TO (6.58/0.78 Ratio)	ZF-22	6	CS
6AS-1000TO (6.75/0.78 Ratio)	ZF-24	6	CS
6S-750 (Ford Only Prior to January 2007)	ZF-45	6	L39
6S-800TO (6.58/0.78 Ratio)	ZF-22	6	CS
6S-850	ZF-23	6	CS
6S-850	ZF-46	6	CS
6S-1000TO (6.75/0.78 Ratio)	ZF-24	6	CS
6S-1200TD (7.72/1.0 Ratio)	ZF-25	6	CS
9S-1110 TD (12.72/1.00 Ratio)	ZF-47	9	CS
9S-1110 TO (9.48/0.75 Ratio)	ZF-47	9	CS
9S-1310 TD (12.72/1.00 Ratio)	ZF-7	9	CS
9S-1310 TO (9.48/0.75 Ratio)	ZF-7	9	CS
9S-1510 TO (9.48/0.75 Ratio)	ZF-7	9	CS
9S-910 TD (12.73/1.00 Ratio)	ZF-7	9	CS
S5-42 (7.5 Gas Wide Ratio)	ZF-4	5	L45-R45
S5-47 (Gas Wide Ratio 5.72/0.76)	ZF-4	5	L45-R45
S6-36 (6.93/0.80 Ratio)	ZF-2	6	CS



IMPORTANT: See Safety Information in Section 1 of the Chelsea Applications catalog HY25-3000/US

Transmission PTO Driver & Apertures (Viewed from Rear of Transmission)
L-Left Side R-Right Side B-Bottom Side T-Top Side CS-Countershaft
For transmissions not listed, contact your authorized Chelsea Distributor.

ZF TRANSMISSION INDEX

Transmission Make and Model	PTO Appl. Number	Number Forward Speeds	Teeth in PTO Driver
S6-36 (7.43/1.00 Ratio)	ZF-35	6	CS
S6-36 (8.97/0.83 Ratio w/ GV36 Splitter)	ZF-33	6	CS
S6-65/AK6-65 (6.70/0.82 Ratio)	ZF-26	6	CS
S6-65/AK6-65 (9.00/1.00 Ratio)	ZF-27	6	CS
S6-66 (7.36/1.00 Ratio)	ZF-52	6	CS
S6-66 (9.06/1.0 Ratio) (Countershaft)	ZF-53	6	CS
S6-70 (6.8/1.0 Ratio)	ZF-54	6	CS
S6-70 (7.36/1.00 Ratio)	ZF-55	6	CS
S6-70 (7.92/1.00 Ratio)	ZF-56	6	CS
S6-70 (9.03/1.00 Ratio)	ZF-57	6	CS
S6-75 (7.52/1.00 Ratio)	ZF-58	6	CS
S6-75 (7.52/1.00 Ratio)	ZF-59	6	CS
S6-80/AK6-80 (6.70/0.73 Ratio) (Countershaft)	ZF-26	6	CS
S6-80/AK6-80 (9.10/1.00 Ratio)	ZF-28	6	CS
S6-90/AK6-90 (6.37/1.00)	ZF-29	6	CS
S6-90/AK6-90 (7.03/0.81 Ratio)	ZF-30	6	CS
S6-90/AK6-90 (9.01/1.00 Ratio) (Countershaft)	ZF-31	6	CS
S6-650 (Ford Truck Models Prior to January 2007)	ZF-45	6	L39
S6-650 (GM 3600 Cab/Chassis - Order Code ML6)	ZF-47	6	L39-R39
SAS-800TO (6.58/0.78 Ratio)	ZF-22	6	CS

ZF



IMPORTANT: See Safety Information
in Section 1 of the Chelsea Applications
catalog HY25-3000/US

Transmission PTO Driver & Apertures (Viewed from Rear of Transmission)
L-Left Side R-Right Side B-Bottom Side T-Top Side CS-Countershaft
For transmissions not listed, contact your authorized Chelsea Distributor.

CHELSEA®

ZF

ZF-2

S6-36 (6.93/0.80 Ratio)

REAR SIDE ONLY

TRANSMISSION GEAR DATA:
REAR 04-BOLT Opening
PITCH LINE TO APERTURE FACE:

CAUTION: Application Approval Required for PTO Output Shaft Speeds Above 2500 RPM

PTO Model	Torq	Dir Rot	Engine %		Filler Block	Adapter Assy	Stud Kit	PTO Model	Torq	Dir Rot	Engine %		Filler Block	Adapter Assy	Stud Kit
	I / C †		Fwd	Rev					I / C †		Fwd	Rev			

REAR MOUNT & THRUSHAFT

524XTAAX-*.*	258 C	Eng	68				Furnished								
524XVAAX-*.*	258 C	Eng	92				Furnished								

† I = Intermittent Torque Only - De-rate Torque Rating 30% for Continuous Duty.

C = Continuous or Intermittent Torque - No need to De-Rate Torque Rating.

IMPORTANT: Refer to the back of this transmission section and read all notes associated with this application page. Some notes may affect the proper PTO selection.

ZF

ZF-4

ZF

CHELSEA®

S5-42 (7.5 Gas Wide Ratio)
S5-47 (Gas Wide Ratio 5.72/0.76)

LEFT SIDE ONLY

RIGHT SIDE ONLY

TRANSMISSION GEAR DATA:

L.S. 06-BOLT Opening Gear FORWARD of Centerline
45 Teeth - R.H. HELIX

PITCH LINE TO APERTURE FACE:
1.1953" (30.3606MM)

TRANSMISSION GEAR DATA:

R.S. 06-BOLT Opening Gear FORWARD of Centerline
45 Teeth - R.H. HELIX

PITCH LINE TO APERTURE FACE:
1.1953" (30.3606MM)

CAUTION: Application Approval Required for PTO Output Shaft Speeds Above 2500 RPM

PTO Model	Torq I / C †	Dir Rot	Engine %		Filler Block	Adapter Assy	Stud Kit	PTO Model	Torq I / C †	Dir Rot	Engine %		Filler Block	Adapter Assy	Stud Kit
			Fwd	Rev							Fwd	Rev			
ONE SPEED - TWO GEAR - MECHANICAL SHIFT															
442XFGSX-*5 (1)	250 I	Opp	53				Furnished	442XFGSX-*3 (1)	250 I	Opp	53				Furnished
442XLGSX-*5 (2)	250 I	Opp	68				Furnished	442XLGSX-*3 (2)	250 I	Opp	68				Furnished
442XQGSX-*5 (2)	225 I	Opp	74				Furnished	442XQGSX-*3 (2)	225 I	Opp	74				Furnished
442XRG SX-*5 (2)	225 I	Opp	85				Furnished	442XRG SX-*3 (2)	225 I	Opp	85				Furnished
442XSGSX-*5 (2)	200 I	Opp	102				Furnished	442XSGSX-*3 (2)	200 I	Opp	102				Furnished
442XUGSX-*5 (2)	195 I	Opp	121				Furnished	442XUGSX-*3 (2)	195 I	Opp	121				Furnished
442XWGSX-*5 (2)	175 I	Opp	142				Furnished	442XWGSX-*3 (2)	175 I	Opp	142				Furnished
442XXGSX-*5 (2)	140 I	Opp	168				Furnished	442XXGSX-*3 (2)	140 I	Opp	168				Furnished

ONE SPEED - FORWARD & REVERSE

340XFEDX-*5 (3)	200 I	Opp	41	43	7-A-140 7-A-270		7170-4X	340XFEDX-*5 (3)	200 I	Opp	41	43	7-A-140 7-A-270		7170-4X
-----------------	-------	-----	----	----	--------------------	--	---------	-----------------	-------	-----	----	----	--------------------	--	---------

† I = Intermittent Torque Only - De-rate Torque Rating 30% for Continuous Duty.

C = Continuous or Intermittent Torque - No need to De-Rate Torque Rating.

IMPORTANT: Refer to the back of this transmission section and read all notes associated with this application page. Some notes may affect the proper PTO selection.

(1) Input Gear Part No. 5-P-1151
(2) Input Gear Part No. 5-P-1152
(3) Input Gear Part No. 5-P-897

ZF

CHELSEA®

ZF

ZF-7

9S-1110 TD (12.72/1.00 Ratio)
9S-1110 TO (9.48/0.75 Ratio)
9S-1310 TD (12.72/1.00 Ratio)
9S-1310 TO (9.48/0.75 Ratio)
9S-1510 TO (9.48/0.75 Ratio)
9S-910 TD (12.73/1.00 Ratio)

REAR SIDE ONLY

TRANSMISSION GEAR DATA:

REAR 04-BOLT Opening

PITCH LINE TO APERTURE FACE:

CAUTION: Application Approval Required for PTO Output Shaft Speeds Above 2500 RPM

PTO Model	Torq	Dir Rot	Engine %		Filler Block	Adapter Assy	Stud Kit	PTO Model	Torq	Dir Rot	Engine %		Filler Block	Adapter Assy	Stud Kit
	I / C †		Fwd	Rev					I / C †		Fwd	Rev			

REAR MOUNT & THRUSHAFT

512XRAQW-V-XY	258 C	Opp	97				Furnished
512XRAQX-V-XK	258 C	Opp	97				Furnished
512XRAQX-V-XV	258 C	Opp	97				Furnished
524XMAQX-*-*	300 C	Opp	100				Furnished
524XTAQX-*-*	300 C	Opp	129				Furnished
524XVAQX-*-*	258 C	Opp	175				Furnished

† I = Intermittent Torque Only - De-rate Torque Rating 30% for Continuous Duty.

C = Continuous or Intermittent Torque - No need to De-Rate Torque Rating.

IMPORTANT: Refer to the back of this transmission section and read all notes associated with this application page. Some notes may affect the proper PTO selection.

ZF

ZF-10

ZF

CHELSEA®

9S-1310 TD (12.72/1.00 Ratio)

LEFT SIDE ONLY

TRANSMISSION GEAR DATA:

REAR 00-BOLT Opening

PITCH LINE TO APERTURE FACE:

CAUTION: Application Approval Required for PTO Output Shaft Speeds Above 2500 RPM

PTO Model	Torq	Dir Rot	Engine %		Filler Block	Adapter Assy	Stud Kit	PTO Model	Torq	Dir Rot	Engine %		Filler Block	Adapter Assy	Stud Kit
	I / C †		Fwd	Rev					I / C †		Fwd	Rev			

REAR MOUNT & THRUSHAFT

512XRAQW-V-XY	258 C	Opp	72				Furnished
512XRAQX-V-XK	258 C	Opp	72				Furnished
512XRAQX-V-XV	258 C	Opp	72				Furnished
524XMAQX-*	300 C	Opp	74				Furnished
524XTAQX-*	300 C	Opp	96				Furnished
524XVAQX-*	258 C	Opp	130				Furnished

† I = Intermittent Torque Only - De-rate Torque Rating 30% for Continuous Duty.

C = Continuous or Intermittent Torque - No need to De-Rate Torque Rating.

IMPORTANT: Refer to the back of this transmission section and read all notes associated with this application page. Some notes may affect the proper PTO selection.

ZF

CHELSEA®

ZF

ZF-22

6S-S800TO
6AS-800TO (6.58/0.78 Ratio)

REAR SIDE ONLY

TRANSMISSION GEAR DATA:

REAR 04-BOLT Opening Gear NON-STANDARD of Centerline
0 Teeth

PITCH LINE TO APERTURE FACE:

0.0000" (0.0000MM)

CAUTION: Application Approval Required for PTO Output Shaft Speeds Above 2500 RPM

PTO Model	Torq	Dir Rot	Engine %		Filler Block	Adapter Assy	Stud Kit	PTO Model	Torq	Dir Rot	Engine %		Filler Block	Adapter Assy	Stud Kit
	I / C †		Fwd	Rev					I / C †		Fwd	Rev			

ONE SPEED - TWO GEAR - MECHANICAL SHIFT

512XRAHW-*XY	258 C	Opp	53				Furnished
512XRAHX-*XK	258 C	Opp	53				Furnished
512XRAHX-*XV	258 C	Opp	53				Furnished
524XTAH-**	258 C	Eng	70				Furnished
524XUAHX-*+	258 C	Eng	81				Furnished
524XVAHX-**	258 C	Eng	95				Furnished

† I = Intermittent Torque Only - De-rate Torque Rating 30% for Continuous Duty.

C = Continuous or Intermittent Torque - No need to De-Rate Torque Rating.

IMPORTANT: Refer to the back of this transmission section and read all notes associated with this application page. Some notes may affect the proper PTO selection.

ZF

ZF-23

ZF

CHELSEA®

6S-850

REAR SIDE ONLY

TRANSMISSION GEAR DATA:

REAR 04-BOLT Opening Gear NON-STANDARD of Centerline
0 Teeth

PITCH LINE TO APERTURE FACE:

0.0000" (0.0000MM)

CAUTION: Application Approval Required for PTO Output Shaft Speeds Above 2500 RPM

PTO Model	Torq	Dir Rot	Engine %		Filler Block	Adapter Assy	Stud Kit	PTO Model	Torq	Dir Rot	Engine %		Filler Block	Adapter Assy	Stud Kit
	I / C †		Fwd	Rev					I / C †		Fwd	Rev			

ONE SPEED - TWO GEAR - MECHANICAL SHIFT

524XTAAX-**-*	258	C	Eng	56											Furnished
524XVAAX-**-*	258	C	Eng	76											Furnished

† I = Intermittent Torque Only - De-rate Torque Rating 30% for Continuous Duty.

C = Continuous or Intermittent Torque - No need to De-Rate Torque Rating.

IMPORTANT: Refer to the back of this transmission section and read all notes associated with this application page. Some notes may affect the proper PTO selection.

ZF

CHELSEA®

ZF

ZF-24

6S-1000TO (6.75/0.78 Ratio)
6AS-1000TO (6.75/0.78 Ratio)

REAR SIDE ONLY

TRANSMISSION GEAR DATA:

REAR 04-BOLT Opening Gear NON-STANDARD of Centerline
0 Teeth

PITCH LINE TO APERTURE FACE:

0.0000" (0.0000MM)

CAUTION: Application Approval Required for PTO Output Shaft Speeds Above 2500 RPM

PTO Model	Torq	Dir Rot	Engine %		Filler Block	Adapter Assy	Stud Kit	PTO Model	Torq	Dir Rot	Engine %		Filler Block	Adapter Assy	Stud Kit
	I / C †		Fwd	Rev					I / C †		Fwd	Rev			

ONE SPEED - TWO GEAR - MECHANICAL SHIFT

512XRAHW-*-XY	258 C	Opp	53				Furnished
512XRAHX-*-XK	258 C	Opp	53				Furnished
512XRAHX-*-XV	258 C	Opp	53				Furnished
524XTAH-*-*	258 C	Eng	70				Furnished
524XUAHX-*-*	258 C	Eng	81				Furnished
524XVAHX-*-*	258 C	Eng	95				Furnished

† I = Intermittent Torque Only - De-rate Torque Rating 30% for Continuous Duty.

C = Continuous or Intermittent Torque - No need to De-Rate Torque Rating.

IMPORTANT: Refer to the back of this transmission section and read all notes associated with this application page. Some notes may affect the proper PTO selection.

ZF

ZF-25

ZF

CHELSEA®

6S-1200TD (7.72/1.0 Ratio)

REAR SIDE ONLY

TRANSMISSION GEAR DATA:

REAR 04-BOLT Opening Gear NON-STANDARD of Centerline
0 Teeth

PITCH LINE TO APERTURE FACE:

0.0000" (0.0000MM)

CAUTION: Application Approval Required for PTO Output Shaft Speeds Above 2500 RPM

PTO Model	Torq	Dir Rot	Engine %		Filler Block	Adapter Assy	Stud Kit	PTO Model	Torq	Dir Rot	Engine %		Filler Block	Adapter Assy	Stud Kit
	I / C †		Fwd	Rev					I / C †		Fwd	Rev			

ONE SPEED - TWO GEAR - MECHANICAL SHIFT

512XRAHW-*XY	258 C	Opp	53				Furnished
512XRAHX-*XK	258 C	Opp	53				Furnished
512XRAHX-*XV	258 C	Opp	53				Furnished
524XTAH-**	258 C	Eng	72				Furnished
524XUAHX-**	258 C	Eng	83				Furnished
524XVAHX-**	258 C	Eng	97				Furnished

† I = Intermittent Torque Only - De-rate Torque Rating 30% for Continuous Duty.

C = Continuous or Intermittent Torque - No need to De-Rate Torque Rating.

IMPORTANT: Refer to the back of this transmission section and read all notes associated with this application page. Some notes may affect the proper PTO selection.

ZF

CHELSEA®

ZF

ZF-26

S6-65/AK6-65 (6.70/0.82 Ratio)
S6-80/AK6-80 (6.70/0.73 Ratio) (Countershaft)

REAR SIDE ONLY

TRANSMISSION GEAR DATA:

REAR 04-BOLT Opening Gear NON-STANDARD of Centerline
0 Teeth

PITCH LINE TO APERTURE FACE:

0.0000" (0.0000MM)

CAUTION: Application Approval Required for PTO Output Shaft Speeds Above 2500 RPM

PTO Model	Torq	Dir Rot	Engine %		Filler Block	Adapter Assy	Stud Kit	PTO Model	Torq	Dir Rot	Engine %		Filler Block	Adapter Assy	Stud Kit
	I / C †		Fwd	Rev					I / C †		Fwd	Rev			

ONE SPEED - TWO GEAR - MECHANICAL SHIFT

512XRAHW-*-XY	258 C	Opp	62				Furnished
512XRAHX-*-XK	258 C	Opp	62				Furnished
512XRAHX-*-XV	258 C	Opp	62				Furnished
524XTAH-*-*	258 C	Eng	83				Furnished
524XUAHX-*-*	258 C	Eng	95				Furnished
524XVAHX-*-*	258 C	Eng	112				Furnished

† I = Intermittent Torque Only - De-rate Torque Rating 30% for Continuous Duty.

C = Continuous or Intermittent Torque - No need to De-Rate Torque Rating.

IMPORTANT: Refer to the back of this transmission section and read all notes associated with this application page. Some notes may affect the proper PTO selection.

ZF

ZF-27

ZF

CHELSEA®

S6-65/AK6-65 (9.00/1.00 Ratio)

REAR SIDE ONLY

TRANSMISSION GEAR DATA:

REAR 04-BOLT Opening Gear NON-STANDARD of Centerline
0 Teeth

PITCH LINE TO APERTURE FACE:

0.0000" (0.0000MM)

CAUTION: Application Approval Required for PTO Output Shaft Speeds Above 2500 RPM

PTO Model	Torq	Dir Rot	Engine %		Filler Block	Adapter Assy	Stud Kit	PTO Model	Torq	Dir Rot	Engine %		Filler Block	Adapter Assy	Stud Kit
	I / C †		Fwd	Rev					I / C †		Fwd	Rev			

ONE SPEED - TWO GEAR - MECHANICAL SHIFT

512XRAHW-*XY	258 C	Opp	46				Furnished
512XRAHX-*XK	258 C	Opp	46				Furnished
512XRAHX-*XV	258 C	Opp	46				Furnished
524XTAH-**	258 C	Eng	61				Furnished
524XUAHX-**	258 C	Eng	71				Furnished
524XVAHX-**	258 C	Eng	83				Furnished

† I = Intermittent Torque Only - De-rate Torque Rating 30% for Continuous Duty.

C = Continuous or Intermittent Torque - No need to De-Rate Torque Rating.

IMPORTANT: Refer to the back of this transmission section and read all notes associated with this application page. Some notes may affect the proper PTO selection.

ZF

CHELSEA®

ZF

ZF-28

S6-80/AK6-80 (9.10/1.00 Ratio)

LEFT SIDE ONLY

TRANSMISSION GEAR DATA:

REAR 04-BOLT Opening Gear NON-STANDARD of Centerline
0 Teeth

PITCH LINE TO APERTURE FACE:

0.0000" (0.0000MM)

CAUTION: Application Approval Required for PTO Output Shaft Speeds Above 2500 RPM

PTO Model	Torq	Dir Rot	Engine %		Filler Block	Adapter Assy	Stud Kit	PTO Model	Torq	Dir Rot	Engine %		Filler Block	Adapter Assy	Stud Kit
	I / C †		Fwd	Rev					I / C †		Fwd	Rev			

ONE SPEED - TWO GEAR - MECHANICAL SHIFT

512XRAHW-*XY	258 C	Opp	46				Furnished
512XRAHX-*XK	258 C	Opp	46				Furnished
512XRAHX-*XV	258 C	Opp	46				Furnished
524XTAH-**	258 C	Eng	61				Furnished
524XUAHX-**	258 C	Eng	71				Furnished
524XVAHX-**	258 C	Eng	83				Furnished

† I = Intermittent Torque Only - De-rate Torque Rating 30% for Continuous Duty.

C = Continuous or Intermittent Torque - No need to De-Rate Torque Rating.

IMPORTANT: Refer to the back of this transmission section and read all notes associated with this application page. Some notes may affect the proper PTO selection.

ZF

ZF-29

ZF

CHELSEA®

S6-90/AK6-90 (6.37-1.00)

REAR SIDE ONLY

TRANSMISSION GEAR DATA:

REAR 04-BOLT Opening Gear NON-STANDARD of Centerline
0 Teeth

PITCH LINE TO APERTURE FACE:

0.0000" (0.0000MM)

CAUTION: Application Approval Required for PTO Output Shaft Speeds Above 2500 RPM

PTO Model	Torq	Dir Rot	Engine %		Filler Block	Adapter Assy	Stud Kit	PTO Model	Torq	Dir Rot	Engine %		Filler Block	Adapter Assy	Stud Kit
	I / C †		Fwd	Rev					I / C †		Fwd	Rev			

ONE SPEED - TWO GEAR - MECHANICAL SHIFT

512XRAHW-*XY	258 C	Opp	66				Furnished
512XRAHX-*XK	258 C	Opp	66				Furnished
512XRAHX-*XV	258 C	Opp	66				Furnished
524XTAH-**	258 C	Eng	88				Furnished
524XUAHX-**	258 C	Eng	101				Furnished
524XVAHX-**	258 C	Eng	119				Furnished

† I = Intermittent Torque Only - De-rate Torque Rating 30% for Continuous Duty.

C = Continuous or Intermittent Torque - No need to De-Rate Torque Rating.

IMPORTANT: Refer to the back of this transmission section and read all notes associated with this application page. Some notes may affect the proper PTO selection.

ZF

CHELSEA®

ZF

ZF-30

S6-90/AK6-90 (7.03/0.81 Ratio)

REAR SIDE ONLY

TRANSMISSION GEAR DATA:

REAR 04-BOLT Opening Gear NON-STANDARD of Centerline
0 Teeth

PITCH LINE TO APERTURE FACE:

0.0000" (0.0000MM)

CAUTION: Application Approval Required for PTO Output Shaft Speeds Above 2500 RPM

PTO Model	Torq	Dir Rot	Engine %		Filler Block	Adapter Assy	Stud Kit	PTO Model	Torq	Dir Rot	Engine %		Filler Block	Adapter Assy	Stud Kit
	I / C †		Fwd	Rev					I / C †		Fwd	Rev			

ONE SPEED - TWO GEAR - MECHANICAL SHIFT

512XRAHW-*XY	258 C	Opp	60				Furnished
512XRAHX-*XK	258 C	Opp	60				Furnished
512XRAHX-*XV	258 C	Opp	60				Furnished
524XTAH-**	258 C	Eng	80				Furnished
524XUAHX-**	258 C	Eng	92				Furnished
524XVAHX-**	258 C	Eng	108				Furnished

† I = Intermittent Torque Only - De-rate Torque Rating 30% for Continuous Duty.

C = Continuous or Intermittent Torque - No need to De-Rate Torque Rating.

IMPORTANT: Refer to the back of this transmission section and read all notes associated with this application page. Some notes may affect the proper PTO selection.

ZF

ZF-31

ZF

CHELSEA®

S6-90/AK6-90 (9.01/1.00 Ratio) (Countershaft)

REAR SIDE ONLY

TRANSMISSION GEAR DATA:

REAR 04-BOLT Opening Gear NON-STANDARD of Centerline
0 Teeth

PITCH LINE TO APERTURE FACE:

0.0000" (0.0000MM)

CAUTION: Application Approval Required for PTO Output Shaft Speeds Above 2500 RPM

PTO Model	Torq	Dir Rot	Engine %		Filler Block	Adapter Assy	Stud Kit	PTO Model	Torq	Dir Rot	Engine %		Filler Block	Adapter Assy	Stud Kit
	I / C †		Fwd	Rev					I / C †		Fwd	Rev			

ONE SPEED - TWO GEAR - MECHANICAL SHIFT

512XRAHW-*XY	258 C	Opp	47				Furnished
512XRAHX-*XK	258 C	Opp	47				Furnished
512XRAHX-*XV	258 C	Opp	47				Furnished
524XTAH-**	258 C	Eng	62				Furnished
524XUAHX-**	258 C	Eng	72				Furnished
524XVAHX-**	258 C	Eng	84				Furnished

† I = Intermittent Torque Only - De-rate Torque Rating 30% for Continuous Duty.

C = Continuous or Intermittent Torque - No need to De-Rate Torque Rating.

IMPORTANT: Refer to the back of this transmission section and read all notes associated with this application page. Some notes may affect the proper PTO selection.

ZF

CHELSEA®

ZF

ZF-33

S6-36 (8.97/0.83 Ratio w/ GV36 Splitter)

REAR SIDE ONLY

TRANSMISSION GEAR DATA:

REAR 04-BOLT Opening Gear NON-STANDARD of Centerline
0 Teeth

PITCH LINE TO APERTURE FACE:

0.0000" (0.0000MM)

CAUTION: Application Approval Required for PTO Output Shaft Speeds Above 2500 RPM

PTO Model	Torq	Dir Rot	Engine %		Filler Block	Adapter Assy	Stud Kit	PTO Model	Torq	Dir Rot	Engine %		Filler Block	Adapter Assy	Stud Kit
	I / C †		Fwd	Rev					I / C †		Fwd	Rev			

ONE SPEED - TWO GEAR - MECHANICAL SHIFT

524XTAAX-*.*	258 C	Eng	53				Furnished								
524XVAAX-*.*	258 C	Eng	72				Furnished								

† I = Intermittent Torque Only - De-rate Torque Rating 30% for Continuous Duty.

C = Continuous or Intermittent Torque - No need to De-Rate Torque Rating.

IMPORTANT: Refer to the back of this transmission section and read all notes associated with this application page. Some notes may affect the proper PTO selection.

ZF

ZF-34

ZF

CHELSEA®

S6-36 (7.43/0.85 Ratio)

REAR SIDE ONLY

TRANSMISSION GEAR DATA:

REAR 04-BOLT Opening Gear NON-STANDARD of Centerline
0 Teeth

PITCH LINE TO APERTURE FACE:

0.0000" (0.0000MM)

CAUTION: Application Approval Required for PTO Output Shaft Speeds Above 2500 RPM

PTO Model	Torq	Dir Rot	Engine %		Filler Block	Adapter Assy	Stud Kit	PTO Model	Torq	Dir Rot	Engine %		Filler Block	Adapter Assy	Stud Kit
	I / C †		Fwd	Rev					I / C †		Fwd	Rev			

ONE SPEED - TWO GEAR - MECHANICAL SHIFT

524XTAAX-*-*	258 C	Eng	64				Furnished
524XVAAX-*-*	258 C	Eng	86				Furnished

† I = Intermittent Torque Only - De-rate Torque Rating 30% for Continuous Duty.

C = Continuous or Intermittent Torque - No need to De-Rate Torque Rating.

IMPORTANT: Refer to the back of this transmission section and read all notes associated with this application page. Some notes may affect the proper PTO selection.

- (1) Input Gear Part No. 5-P-1515-1X
- (2) Input Gear Part No. 5-P-1515-2X
- (3) Input Gear Part No. 5-P-1515-3X
- (4) Input Gear Part No. 5-P-1515-4X

CHELSEA®

ZF

ZF-35

S6-36 (7.43/1.00 Ratio)

REAR SIDE ONLY

TRANSMISSION GEAR DATA:

REAR 04-BOLT Opening Gear NON-STANDARD of Centerline
0 Teeth

PITCH LINE TO APERTURE FACE:

0.0000" (0.0000MM)

CAUTION: Application Approval Required for PTO Output Shaft Speeds Above 2500 RPM

PTO Model	Torq	Dir Rot	Engine %		Filler Block	Adapter Assy	Stud Kit	PTO Model	Torq	Dir Rot	Engine %		Filler Block	Adapter Assy	Stud Kit
	I / C †		Fwd	Rev					I / C †		Fwd	Rev			

ONE SPEED - TWO GEAR - MECHANICAL SHIFT

524XTAAX-*.*	258 C	Eng	63				Furnished								
524XVAAX-*.*	258 C	Eng	86				Furnished								

† I = Intermittent Torque Only - De-rate Torque Rating 30% for Continuous Duty.

C = Continuous or Intermittent Torque - No need to De-Rate Torque Rating.

IMPORTANT: Refer to the back of this transmission section and read all notes associated with this application page. Some notes may affect the proper PTO selection.

- (1) Input Gear Part No. 5-P-1515-1X
- (2) Input Gear Part No. 5-P-1515-2X
- (3) Input Gear Part No. 5-P-1515-3X
- (4) Input Gear Part No. 5-P-1515-4X

ZF-45

ZF

CHELSEA®

6S-650 (Ford Only Prior to January 2007)
6S-750 (Ford Only Prior to January 2007)

LEFT SIDE ONLY

TRANSMISSION GEAR DATA:

L.S. 06-BOLT Opening Gear FORWARD of Centerline
39 Teeth - R.H. HELIX

PITCH LINE TO APERTURE FACE:
0.9330" (23.6982MM)

CAUTION: Application Approval Required for PTO Output Shaft Speeds Above 2500 RPM

PTO Model	Torq	Dir Rot	Engine %		Filler Block	Adapter Assy	Stud Kit	PTO Model	Torq	Dir Rot	Engine %		Filler Block	Adapter Assy	Stud Kit
	I / C †		Fwd	Rev					I / C †		Fwd	Rev			

ONE SPEED - TWO GEAR - MECHANICAL SHIFT

442XLHYX-*5 (1)	250 I	Opp	65				Furnished
442XQHYX-*5 (1)	225 I	Opp	70				Furnished
442XRHYX-*5 (1)	225 I	Opp	81				Furnished
442XSHYX-*5 (1)	200 I	Opp	96				Furnished
442XUHYX-*5 (1)	195 I	Opp	115				Furnished
442XWHYX-*5 (1)	175 I	Opp	135				Furnished
442XXHYX-*5 (1)	140 I	Opp	160				Furnished

† I = Intermittent Torque Only - De-rate Torque Rating 30% for Continuous Duty.

C = Continuous or Intermittent Torque - No need to De-Rate Torque Rating.

IMPORTANT: Refer to the back of this transmission section and read all notes associated with this application page. Some notes may affect the proper PTO selection.

(1) Input Gear Part No. 5-P-1237
(2) Input Gear Part No. 5-P-1245

CHELSEA®

ZF

ZF-46

6S-850

REAR SIDE ONLY

TRANSMISSION GEAR DATA:

REAR 04-BOLT Opening

PITCH LINE TO APERTURE FACE:

CAUTION: Application Approval Required for PTO Output Shaft Speeds Above 2500 RPM

PTO Model	Torq	Dir Rot	Engine %		Filler Block	Adapter Assy	Stud Kit	PTO Model	Torq	Dir Rot	Engine %		Filler Block	Adapter Assy	Stud Kit
	I / C †		Fwd	Rev					I / C †		Fwd	Rev			

REAR MOUNT - MECHANICAL SHIFT (6 SPEED TRANSMISSIONS)

524XTAAX-*.*	258 C	Eng	70				Furnished
524XVAAX-*.*	258 C	Eng	95				Furnished

† I = Intermittent Torque Only - De-rate Torque Rating 30% for Continuous Duty.

C = Continuous or Intermittent Torque - No need to De-Rate Torque Rating.

IMPORTANT: Refer to the back of this transmission section and read all notes associated with this application page. Some notes may affect the proper PTO selection.

- (1) Input Gear Part No. 5-P-1515-1X
- (2) Input Gear Part No. 5-P-1515-2X
- (3) Input Gear Part No. 5-P-1515-3X
- (4) Input Gear Part No. 5-P-1515-4X

ZF-47

ZF

CHELSEA®

S6-650 (GM 3600 Cab/Chassis - Order Code ML6)

LEFT SIDE ONLY

RIGHT SIDE ONLY

TRANSMISSION GEAR DATA:

L.S. 06-BOLT Opening Gear FORWARD of Centerline
39 Teeth - R.H. HELIX

PITCH LINE TO APERTURE FACE:
0.9330" (23.6982MM)

TRANSMISSION GEAR DATA:

R.S. 06-BOLT Opening Gear FORWARD of Centerline
39 Teeth - R.H. HELIX

PITCH LINE TO APERTURE FACE:
0.9330" (23.6982MM)

CAUTION: Application Approval Required for PTO Output Shaft Speeds Above 2500 RPM

PTO Model	Torq	Dir Rot	Engine %		Filler Block	Adapter Assy	Stud Kit	PTO Model	Torq	Dir Rot	Engine %		Filler Block	Adapter Assy	Stud Kit
	I / C †		Fwd	Rev					I / C †		Fwd	Rev			

ONE SPEED - TWO GEAR - MECHANICAL SHIFT

442XLHYX-*5 (1)	250 I	Opp	65				Furnished	442XLHYX-*5 (1)	250 I	Opp	65				Furnished
442XQHYX-*5 (1)	225 I	Opp	70				Furnished	442XQHYX-*5 (1)	225 I	Opp	70				Furnished
442XRHYX-*5 (1)	225 I	Opp	81				Furnished	442XRHYX-*5 (1)	225 I	Opp	81				Furnished
442XSHYX-*5 (1)	200 I	Opp	96				Furnished	442XSHYX-*5 (1)	200 I	Opp	96				Furnished
442XUHYX-*5 (1)	195 I	Opp	115				Furnished	442XUHYX-*5 (1)	195 I	Opp	115				Furnished
442XWHYX-*5 (1)	175 I	Opp	135				Furnished	442XWHYX-*5 (1)	175 I	Opp	135				Furnished
442XXHYX-*5 (1)	140 I	Opp	160				Furnished	442XXHYX-*5 (1)	140 I	Opp	160				Furnished

ONE SPEED - FORWARD & REVERSE

340XFHYX-*5 (2)	200 I	Opp	46	48			Furnished								
-----------------	-------	-----	----	----	--	--	-----------	--	--	--	--	--	--	--	--

GEARED ADAPTERS

626XHYX-4JB (1)	250 I	Eng					Furnished								
630XHYX-4JB (1)	250 I	Eng					Furnished								
645XHYX-4JB (1)	250 I	Eng					Furnished								

† I = Intermittent Torque Only - De-rate Torque Rating 30% for Continuous Duty.

C = Continuous or Intermittent Torque - No need to De-Rate Torque Rating.

IMPORTANT: Refer to the back of this transmission section and read all notes associated with this application page. Some notes may affect the proper PTO selection.

CAUTION: It is required by GM Truck that the 442 Series when mounted on the right side of the transmission must have the direct mount pump, with hard tubing coming out of the rear of the pump, up and over the transmission output shaft, and a heat shield must be installed to cover the PTO and the pump. Order Kit number 329333X for complete pump and heat shield installation parts.

(1) Input Gear Part No. 5-P-1237
(2) Input Gear Part No. 5-P-1245

ZF

CHELSEA®

ZF

ZF-52

S6-66 (7.36/1.00 Ratio)

REAR SIDE ONLY

TRANSMISSION GEAR DATA:

REAR 04-BOLT Opening Gear NON-STANDARD of Centerline
0 Teeth

PITCH LINE TO APERTURE FACE:

0.0000" (0.0000MM)

CAUTION: Application Approval Required for PTO Output Shaft Speeds Above 2500 RPM

PTO Model	Torq	Dir Rot	Engine %		Filler Block	Adapter Assy	Stud Kit	PTO Model	Torq	Dir Rot	Engine %		Filler Block	Adapter Assy	Stud Kit
	I / C †		Fwd	Rev					I / C †		Fwd	Rev			

ONE SPEED - TWO GEAR - MECHANICAL SHIFT

512XRAHW-*-XY	258 C	Opp	52				Furnished
512XRAHX-*-XK	258 C	Opp	52				Furnished
512XRAHX-*-XV	258 C	Opp	52				Furnished
524XTAH-*-*	258 C	Eng	69				Furnished
524XUAHX-*-*	258 C	Eng	80				Furnished
524XVAHX-*-*	258 C	Eng	94				Furnished

† I = Intermittent Torque Only - De-rate Torque Rating 30% for Continuous Duty.

C = Continuous or Intermittent Torque - No need to De-Rate Torque Rating.

IMPORTANT: Refer to the back of this transmission section and read all notes associated with this application page. Some notes may affect the proper PTO selection.

ZF

ZF-53

ZF

CHELSEA®

S6-66 (9.06-1.0 Ratio) (Countershaft)

REAR SIDE ONLY

TRANSMISSION GEAR DATA:

REAR 04-BOLT Opening Gear NON-STANDARD of Centerline
0 Teeth

PITCH LINE TO APERTURE FACE:

0.0000" (0.0000MM)

CAUTION: Application Approval Required for PTO Output Shaft Speeds Above 2500 RPM

PTO Model	Torq	Dir Rot	Engine %		Filler Block	Adapter Assy	Stud Kit	PTO Model	Torq	Dir Rot	Engine %		Filler Block	Adapter Assy	Stud Kit
	I / C †		Fwd	Rev					I / C †		Fwd	Rev			

ONE SPEED - TWO GEAR - MECHANICAL SHIFT

512XRAHW-*XY	258 C	Opp	42				Furnished
512XRAHX-*XK	258 C	Opp	42				Furnished
512XRAHX-*XV	258 C	Opp	42				Furnished
524XTAH-**	258 C	Eng	55				Furnished
524XUAHX-**	258 C	Eng	64				Furnished
524XVAHX-**	258 C	Eng	75				Furnished

† I = Intermittent Torque Only - De-rate Torque Rating 30% for Continuous Duty.

C = Continuous or Intermittent Torque - No need to De-Rate Torque Rating.

IMPORTANT: Refer to the back of this transmission section and read all notes associated with this application page. Some notes may affect the proper PTO selection.

ZF

CHELSEA®

ZF

ZF-54

S6-70 (6.8/1.0 Ratio)

REAR SIDE ONLY

TRANSMISSION GEAR DATA:

REAR 04-BOLT Opening Gear NON-STANDARD of Centerline
0 Teeth

PITCH LINE TO APERTURE FACE:

0.0000" (0.0000MM)

CAUTION: Application Approval Required for PTO Output Shaft Speeds Above 2500 RPM

PTO Model	Torq	Dir Rot	Engine %		Filler Block	Adapter Assy	Stud Kit	PTO Model	Torq	Dir Rot	Engine %		Filler Block	Adapter Assy	Stud Kit
	I / C †		Fwd	Rev					I / C †		Fwd	Rev			

ONE SPEED - TWO GEAR - MECHANICAL SHIFT

512XRAHW-*-XY	258 C	Opp	51				Furnished
512XRAHX-*-XK	258 C	Opp	51				Furnished
512XRAHX-*-XV	258 C	Opp	51				Furnished
524XTAH-*-*	258 C	Eng	68				Furnished
524XUAHX-*-*	258 C	Eng	79				Furnished
524XVAHX-*-*	258 C	Eng	93				Furnished

† I = Intermittent Torque Only - De-rate Torque Rating 30% for Continuous Duty.

C = Continuous or Intermittent Torque - No need to De-Rate Torque Rating.

IMPORTANT: Refer to the back of this transmission section and read all notes associated with this application page. Some notes may affect the proper PTO selection.

ZF

ZF-55

ZF

CHELSEA®

S6-70 (7.36/1.00 Ratio)

REAR SIDE ONLY

TRANSMISSION GEAR DATA:

REAR 04-BOLT Opening Gear NON-STANDARD of Centerline
0 Teeth

PITCH LINE TO APERTURE FACE:

0.0000" (0.0000MM)

CAUTION: Application Approval Required for PTO Output Shaft Speeds Above 2500 RPM

PTO Model	Torq	Dir Rot	Engine %		Filler Block	Adapter Assy	Stud Kit	PTO Model	Torq	Dir Rot	Engine %		Filler Block	Adapter Assy	Stud Kit
	I / C †		Fwd	Rev					I / C †		Fwd	Rev			

ONE SPEED - TWO GEAR - MECHANICAL SHIFT

512XRAHW-*XY	258 C	Opp	48				Furnished
512XRAHX-*XK	258 C	Opp	48				Furnished
512XRAHX-*XV	258 C	Opp	48				Furnished
524XTAH-**	258 C	Eng	64				Furnished
524XUAHX-**	258 C	Eng	73				Furnished
524XVAHX-**	258 C	Eng	86				Furnished

† I = Intermittent Torque Only - De-rate Torque Rating 30% for Continuous Duty.

C = Continuous or Intermittent Torque - No need to De-Rate Torque Rating.

IMPORTANT: Refer to the back of this transmission section and read all notes associated with this application page. Some notes may affect the proper PTO selection.

ZF

CHELSEA®

ZF

ZF-56

S6-70 (7.92/1.00 Ratio)

REAR SIDE ONLY

TRANSMISSION GEAR DATA:

REAR 04-BOLT Opening Gear NON-STANDARD of Centerline
0 Teeth

PITCH LINE TO APERTURE FACE:

0.0000" (0.0000MM)

CAUTION: Application Approval Required for PTO Output Shaft Speeds Above 2500 RPM

PTO Model	Torq	Dir Rot	Engine %		Filler Block	Adapter Assy	Stud Kit	PTO Model	Torq	Dir Rot	Engine %		Filler Block	Adapter Assy	Stud Kit
	I / C †		Fwd	Rev					I / C †		Fwd	Rev			

ONE SPEED - TWO GEAR - MECHANICAL SHIFT

512XRAHW-*-XY	258 C	Opp	44				Furnished
512XRAHX-*-XK	258 C	Opp	44				Furnished
512XRAHX-*-XV	258 C	Opp	44				Furnished
524XTAH-*-*	258 C	Eng	59				Furnished
524XUAHX-*-*	258 C	Eng	67				Furnished
524XVAHX-*-*	258 C	Eng	79				Furnished

† I = Intermittent Torque Only - De-rate Torque Rating 30% for Continuous Duty.

C = Continuous or Intermittent Torque - No need to De-Rate Torque Rating.

IMPORTANT: Refer to the back of this transmission section and read all notes associated with this application page. Some notes may affect the proper PTO selection.

ZF

ZF-57

ZF

CHELSEA®

S6-70 (9.03/1.00 Ratio)

REAR SIDE ONLY

TRANSMISSION GEAR DATA:

REAR 04-BOLT Opening Gear NON-STANDARD of Centerline
0 Teeth

PITCH LINE TO APERTURE FACE:

0.0000" (0.0000MM)

CAUTION: Application Approval Required for PTO Output Shaft Speeds Above 2500 RPM

PTO Model	Torq	Dir Rot	Engine %		Filler Block	Adapter Assy	Stud Kit	PTO Model	Torq	Dir Rot	Engine %		Filler Block	Adapter Assy	Stud Kit
	I / C †		Fwd	Rev					I / C †		Fwd	Rev			

ONE SPEED - TWO GEAR - MECHANICAL SHIFT

512XRAHW-*XY	258 C	Opp	39				Furnished
512XRAHX-*XK	258 C	Opp	39				Furnished
512XRAHX-*XV	258 C	Opp	39				Furnished
524XTAH-**	258 C	Eng	51				Furnished
524XUAHX-**	258 C	Eng	59				Furnished
524XVAHX-**	258 C	Eng	70				Furnished

† I = Intermittent Torque Only - De-rate Torque Rating 30% for Continuous Duty.

C = Continuous or Intermittent Torque - No need to De-Rate Torque Rating.

IMPORTANT: Refer to the back of this transmission section and read all notes associated with this application page. Some notes may affect the proper PTO selection.

ZF

CHELSEA®

ZF

ZF-58

S6-75 (7.52/1.00 Ratio)

REAR SIDE ONLY

TRANSMISSION GEAR DATA:

REAR 04-BOLT Opening Gear NON-STANDARD of Centerline
0 Teeth

PITCH LINE TO APERTURE FACE:

0.0000" (0.0000MM)

CAUTION: Application Approval Required for PTO Output Shaft Speeds Above 2500 RPM

PTO Model	Torq	Dir Rot	Engine %		Filler Block	Adapter Assy	Stud Kit	PTO Model	Torq	Dir Rot	Engine %		Filler Block	Adapter Assy	Stud Kit
	I / C †		Fwd	Rev					I / C †		Fwd	Rev			

ONE SPEED - TWO GEAR - MECHANICAL SHIFT

512XRAHW-*XY	258 C	Opp	37				Furnished
512XRAHX-*XK	258 C	Opp	37				Furnished
512XRAHX-*XV	258 C	Opp	37				Furnished
524XTAH-**	258 C	Eng	49				Furnished
524XUAHX-*+	258 C	Eng	56				Furnished
524XVAHX-**	258 C	Eng	66				Furnished

† I = Intermittent Torque Only - De-rate Torque Rating 30% for Continuous Duty.

C = Continuous or Intermittent Torque - No need to De-Rate Torque Rating.

IMPORTANT: Refer to the back of this transmission section and read all notes associated with this application page. Some notes may affect the proper PTO selection.

ZF

ZF-59

ZF

CHELSEA®

S6-75 (7.52/1.00 Ratio)

REAR SIDE ONLY

TRANSMISSION GEAR DATA:

REAR 04-BOLT Opening Gear NON-STANDARD of Centerline
0 Teeth

PITCH LINE TO APERTURE FACE:

0.0000" (0.0000MM)

CAUTION: Application Approval Required for PTO Output Shaft Speeds Above 2500 RPM

PTO Model	Torq	Dir Rot	Engine %		Filler Block	Adapter Assy	Stud Kit	PTO Model	Torq	Dir Rot	Engine %		Filler Block	Adapter Assy	Stud Kit
	I / C †		Fwd	Rev					I / C †		Fwd	Rev			

ONE SPEED - TWO GEAR - MECHANICAL SHIFT

512XRAHW-*XY	258 C	Opp	55				Furnished
512XRAHX-*XK	258 C	Opp	55				Furnished
512XRAHX-*XV	258 C	Opp	55				Furnished
524XTAH-**	258 C	Eng	74				Furnished
524XUAHX-**	258 C	Eng	85				Furnished
524XVAHX-**	258 C	Eng	100				Furnished

† I = Intermittent Torque Only - De-rate Torque Rating 30% for Continuous Duty.

C = Continuous or Intermittent Torque - No need to De-Rate Torque Rating.

IMPORTANT: Refer to the back of this transmission section and read all notes associated with this application page. Some notes may affect the proper PTO selection.

ZF

CHELSEA®

ZF

ZF-64

12AS-1930TO (AS-Tronic)
12AS-2130TO (AS-Tronic)
12AS-2301 (AS-Tronic - 12.33/0.78 Ratio)
12AS-2330TO (AS-Tronic)
12AS-2530TO (AS-Tronic)
12AS-2540TO (AS-Tronic)
12AS-2740TO (AS-Tronic)
12AS-2940TO (AS-Tronic)

REAR SIDE ONLY

TRANSMISSION GEAR DATA:

REAR 00-BOLT Opening

PITCH LINE TO APERTURE FACE:

CAUTION: Application Approval Required for PTO Output Shaft Speeds Above 2500 RPM

PTO Model	Torq	Dir Rot	Engine %		Filler Block	Adapter Assy	Stud Kit	PTO Model	Torq	Dir Rot	Engine %		Filler Block	Adapter Assy	Stud Kit
	I / C †		Fwd	Rev					I / C †		Fwd	Rev			

REAR MOUNT - MECHANICAL SHIFT (12 SPEED TRANSMISSIONS)

524XMACX-F-*	300 C	Eng	139				Furnished
524XTACX-F-*	300 C	Eng	180				Furnished
524XVACX-F-*	258 C	Eng	243				Furnished

† I = Intermittent Torque Only - De-rate Torque Rating 30% for Continuous Duty.

C = Continuous or Intermittent Torque - No need to De-Rate Torque Rating.

IMPORTANT: Refer to the back of this transmission section and read all notes associated with this application page. Some notes may affect the proper PTO selection.

ZF

ZF-65

ZF

CHELSEA®

16AS-2601 (AS-Tronic - 14.12/0.83 Ratio)
16AS-2630TO (AS-Tronic)

REAR SIDE ONLY

TRANSMISSION GEAR DATA:

REAR 00-BOLT Opening

PITCH LINE TO APERTURE FACE:

CAUTION: Application Approval Required for PTO Output Shaft Speeds Above 2500 RPM

PTO Model	Torq	Dir Rot	Engine %		Filler Block	Adapter Assy	Stud Kit	PTO Model	Torq	Dir Rot	Engine %		Filler Block	Adapter Assy	Stud Kit
	I / C †		Fwd	Rev					I / C †		Fwd	Rev			

REAR MOUNT - MECHANICAL SHIFT (16 SPEED TRANSMISSIONS)

524XMACX-F-*	300 C	Eng	114				Furnished
524XTACX-F-*	300 C	Eng	148				Furnished
524XVACX-F-*	258 C	Eng	200				Furnished

† I = Intermittent Torque Only - De-rate Torque Rating 30% for Continuous Duty.

C = Continuous or Intermittent Torque - No need to De-Rate Torque Rating.

IMPORTANT: Refer to the back of this transmission section and read all notes associated with this application page. Some notes may affect the proper PTO selection.

ZF

CHELSEA®

ZF

ZF-66

12AS-1630TD (AS-Tronic)
12AS-1930TD (AS-Tronic)
12AS-2130TD (AS-Tronic)
12AS-2140TD (AS-Tronic)
12AS-2301 (AS-Tronic - 15.86/1.0 Ratio)
12AS-2330TD (AS-Tronic)
12AS-2340TD (AS-Tronic)
12AS-2530TD (AS-Tronic)

12AS-2540TD (AS-Tronic)

REAR SIDE ONLY

TRANSMISSION GEAR DATA:

REAR 00-BOLT Opening

PITCH LINE TO APERTURE FACE:

CAUTION: Application Approval Required for PTO Output Shaft Speeds Above 2500 RPM

PTO Model	Torq	Dir Rot	Engine %		Filler Block	Adapter Assy	Stud Kit	PTO Model	Torq	Dir Rot	Engine %		Filler Block	Adapter Assy	Stud Kit
	I / C †		Fwd	Rev					I / C †		Fwd	Rev			

REAR MOUNT - MECHANICAL SHIFT (12 SPEED TRANSMISSIONS)

524XMACX-F-*	300 C	Eng	84				Furnished
524XTACX-F-*	300 C	Eng	109				Furnished
524XVACX-F-*	258 C	Eng	148				Furnished

† I = Intermittent Torque Only - De-rate Torque Rating 30% for Continuous Duty.

C = Continuous or Intermittent Torque - No need to De-Rate Torque Rating.

IMPORTANT: Refer to the back of this transmission section and read all notes associated with this application page. Some notes may affect the proper PTO selection.

ZF

ZF-67

ZF

CHELSEA®

16AS-2601 (AS-Tronic - 17.03/1.0 Ratio)

REAR SIDE ONLY

TRANSMISSION GEAR DATA:

REAR 00-BOLT Opening Gear NON-STANDARD of Centerline
0 Teeth

PITCH LINE TO APERTURE FACE:

0.0000" (0.0000MM)

CAUTION: Application Approval Required for PTO Output Shaft Speeds Above 2500 RPM

PTO Model	Torq	Dir Rot	Engine %		Filler Block	Adapter Assy	Stud Kit	PTO Model	Torq	Dir Rot	Engine %		Filler Block	Adapter Assy	Stud Kit
	I / C †		Fwd	Rev					I / C †		Fwd	Rev			

ONE SPEED - TWO GEAR - MECHANICAL SHIFT

524XMACX-F-*	300 C	Eng	78				Furnished
524XTACX-F-*	300 C	Eng	101				Furnished
524XVACX-F-*	300 C	Eng	137				Furnished

† I = Intermittent Torque Only - De-rate Torque Rating 30% for Continuous Duty.

C = Continuous or Intermittent Torque - No need to De-Rate Torque Rating.

IMPORTANT: Refer to the back of this transmission section and read all notes associated with this application page. Some notes may affect the proper PTO selection.

ZF

ZF Notes

ZF-4

1. No adapters available for this application.
2. The 100 Series will not mount on the left side due to interference with the reverse idler bulge.
3. Gas tank may prohibit the remote mounting of a hydraulic pump on the Left Hand side.
4. If there is interference with the exhaust system at the right hand aperture, use assembly arrangement 5.
5. Chelsea pump model P16-45 thru-85 can be direct mounted to PTOs. Larger pumps can not be direct mounted due to interference with the transmission.

ZF-7

1. 512/524 Rear Mounts - The adapter 329997X is furnished with the PTO

ZF-10

1. 512/524 Rear Mounts - The adapter 329997X is furnished with the PTO

ZF-33

1. For Rear Mounts - Speeds are shown in LOW split, multiply speed shown by 1.2 for speeds in HIGH split.

ZF-34

1. For Rear Mounts - Speeds are shown in LOW split, multiply speed shown by 1.16 for speeds in HIGH split.

ZF-35

1. For Rear Mounts - Speeds are shown in LOW split, multiply speed shown by 1.18 for speeds in HIGH split.

ZF-45

1. A 5 assembly is shown here, but other assembly arrangements may work better depending on the chassis setup, whether or not a direct mount pump is to be used, and whether or not a geared adapter is to be used. Chelsea P16-45 and -65 pumps can be direct mounted rearward if the PTO is a 3 assembly (bulge up), uses the XK pump flange, and is the L, R, S or U ratio. All other combinations will have interference problems. Chelsea P16-45 and -65 pumps can be direct mounted forward if a 4 assembly is used (bulge down), an XK pump flange is used, and is the L, R, S, or U ratio. All other combinations will have interference problems. Other ratios, assemblies, pump flanges and pumps may work if a geared adapter is used, but the PTO may be the lowest component on the truck. It would be vulnerable to damage.
2. The 236 series cannot be used on this transmission unless the truck is equipped with an auxiliary air supply.
3. If a 626, 630 or 645 series geared adapter is used, the PTO input gear is the 5-P-1244 JB gear, and the HY gear is used in the adapter. If a 626XHY, 630XHY or 645XHY Series geared adapter is going to be used, the PTO must be a deep mount (ex: 442Z*JB). Use a 7-A-125 filler block, gaskets to establish .006"-.012" backlash, and a 328170-76X stud kit to mount the PTO to the adapter. Be aware that using a geared adapter will change the direction of PTO rotation, but will not affect the speeds shown above.
4. Refer to Ford Body Builders Book (Power Take-Off Applications SEIC/PTO) for information on removal of a tab on the M60D transmission case. This will help in direct mount pump installations.
5. Ford Super Duty MY 2005 applications with the 6.8L gas engine may have PTO to engine exhaust pipe interference problems. It is recommended that you use an assembly arrangement 3. This still leaves the PTO close to the engine exhaust pipe. Route cable and wiring away from the exhaust pipe. Heat may be an issue for PTO operation due to the proximity of the engine exhaust pipe.

ZF Notes

ZF-47

1. Only 442 Series with the CABLE SHIFT option W and a SAE A 2 bolt output flange RC must be used on right side applications. The 442 Series must be "Shaft High" 5 assembly arrangement due to exhaust pipe interference. RC field conversion kit number 328591-112X ("XD" to RC)
2. There is a left and right PTO opening for GM/ ZF S6-650, the LEFT side aperture can be used in 4 x 2 vehicles. There is a interference on the 4 x 4 vehicles due to the front wheel driveshaft on the LEFT side.
3. The 626 and 645 Series adapters will mount to this transmission (LEFT Side Only) with the 5-P-1237 gear in the adapter and the 5-P-1244 gear in the 442 Series. The 442 Series must use a deep mount housing, stud kit 328170-76X and 7-A-125 spacer to mount to the adapter.
4. Parker P16-45/65 pumps can be mounted rearward and direct to the 442 series on the LEFT side if the PTO is a 3 assembly, (bulge up), has the XK or RC flange, and is the F, L, R, S, or U ratio.
5. Wiring harness assembly number 329333-4X can be used on all applications to control engine speed. See owner's manual HY25-1135-M1/US for complete instructions.

ZF-58

1. For Rear Mounts - Speeds are shown in LOW split, multiply speed shown by 1.12 for speeds in HIGH split

ZF-59

1. For Rear Mounts - Speeds are shown in LOW split, multiply speed shown by 1.12 for speeds in HIGH split

ZF-64

1. 524 Rear Mount - The adapter 329993X is furnished with the PTO

ZF-65

1. 524 Rear Mount - The adapter 329993X is furnished with the PTO

ZF-66

1. 524 Rear Mount - The adapter 329993X is furnished with the PTO

ZF-67

1. 524 Rear Mount - The adapter 329993X is furnished with the PTO

Offer of Sale

- 1. Definitions.** As used herein, the following terms have the meanings indicated.
- Buyer:** means any customer receiving a Quote for Products.
- Buyer's Property:** means any tools, patterns, plans, drawings, designs, specifications materials, equipment, or information furnished by Buyer, or which are or become Buyer's property.
- Confidential Information:** means any technical, commercial, or other proprietary information of Seller, including, without limitation, pricing, technical drawings or prints and/or part lists, which has been or will be disclosed, delivered, or made available, whether directly or indirectly, to Buyer.
- Goods:** means any tangible part, system or component to be supplied by Seller.
- Intellectual Property Rights:** means any patents, trademarks, copyrights, trade dress, trade secrets or similar rights.
- Products:** means the Goods, Services and/or Software as described in a Quote.
- Quote:** means the offer or proposal made by Seller to Buyer for the supply of Products.
- Seller:** means Parker-Hannifin Corporation, all divisions, subsidiaries and businesses selling products under these terms.
- Seller's IP:** means patents, trademarks, copyrights, or other intellectual property rights relating to the Products, including without limitation, names, designs, images, drawings, models, software, templates, information, any improvements or creations or other intellectual property developed prior to or during the relationship contemplated herein.
- Services:** means any services to be provided by Seller.
- Software:** means any software related to the Goods, whether embedded or separately downloaded.
- Special Tooling:** means equipment acquired by Seller or otherwise owned by Seller necessary to manufacture Goods, including but not limited to tools, jigs, and fixtures.
- Terms:** means the terms and conditions of this Offer of Sale.
- 2. Terms.** All sales of Products by Seller will be governed by, and are expressly conditioned upon Buyer's assent to, these Terms. These Terms are incorporated into any Quote provided by Seller to Buyer. Buyer's order for any Products whether communicated to Seller verbally, in writing, by electronic data interface or other electronic commerce, shall constitute acceptance of these Terms. Seller objects to any contrary or additional terms or conditions of Buyer. Reference in Seller's order acknowledgement to Buyer's purchase order or purchase order number shall in no way constitute an acceptance of any of Buyer's terms or conditions of purchase. Any Quote made by Seller to Buyer shall be considered a firm and definite offer and shall not be deemed to be otherwise despite any language on the face of the Quote. Seller reserves all rights to accept or reject any purported acceptance by Buyer to Seller's Quote if such purported acceptance attempts to vary the terms of the Quote. If Seller ships Products after Buyer issues an acceptance to the Quote, any additional or different terms proposed by Buyer will not become part of the parties' business relationship unless agreed to in a writing that is signed by an authorized representative of Seller, excluding email correspondence. If the

transaction proceeds without such agreement on the part of Seller, the business relationship will be governed solely by these Terms and the specific terms in Seller's Quote.

3. Price; Payment. The Products set forth in the Quote are offered for sale at the prices indicated in the Quote. Unless otherwise specifically stated in the Quote, prices are valid for thirty (30) days and do not include any sales, use, or other taxes or duties. Seller reserves the right to modify prices for any reason and at any time by giving ten (10) days prior written notice. Unless otherwise specified by Seller, all prices are F.C.A. Seller's facility (INCOTERMS 2020). All sales are contingent upon credit approval and full payment for all purchases is due thirty (30) days from the date of invoice (or such date as may be specified in the Quote). Under any circumstances, Buyer may not withhold or suspend payment of any amounts due and payable as a deduction, set-off or recoupment of any amount, claim or dispute with Seller. Unpaid invoices beyond the specified payment date incur interest at the rate of 1.5% per month or the maximum allowable rate under applicable law. Seller reserves the right to require advance payment or provision of securities for first and subsequent deliveries if there is any doubt, in Seller's sole determination, regarding the Buyer's creditworthiness or for other business reasons. If the requested advance payment or securities are not provided to Seller's satisfaction, Seller reserves the right to suspend performance or reject the purchase order, in whole or in part, without prejudice to Seller's other rights or remedies, including the right to full compensation. Seller may revoke or shorten any payment periods previously granted in Seller's sole determination. The rights and remedies herein reserved to Seller are cumulative and in addition to any other or further rights and remedies available at law or in equity. No waiver by Seller of any breach by Buyer of any provision of these terms will constitute a waiver by Seller of any other breach of such provision.

4. Shipment; Delivery; Title and Risk of Loss. All delivery dates are approximate, and Seller is not responsible for damages or additional costs resulting from any delay. All deliveries are subject to our ability to procure materials from our suppliers. Regardless of the manner of shipment, delivery occurs and title and risk of loss or damage pass to Buyer, upon placement of the Products with the carrier at Seller's facility. Unless otherwise agreed prior to shipment and for domestic delivery locations only, Seller will select and arrange, at Buyer's sole expense, the carrier and means of delivery. When Seller selects and arranges the carrier and means of delivery, freight and insurance costs for shipment to the designated delivery location will be prepaid by Seller and added as a separate line item to the invoice. Buyer shall be responsible for any additional shipping charges incurred by Seller due to Buyer's acts or omissions. Buyer shall not return or repackage any Products without the prior written authorization from Seller, and any return shall be at the sole cost and expense of Buyer.

5. Warranty. The warranty for the Products is as follows: (i) Seller warrants that all products sold conform to the applicable Parker Chelsea standard specification for the lesser period of 2 years (24 Months) from date of service or 2-1/2 years (30 Months) from date of build (as marked on the product name plate); (ii) Services shall be performed in accordance with generally accepted practices and using the degree of care and skill that is ordinarily exercised and customary in the field to which the Services pertain and are warranted for a period of six (6) months from the date of completion of the Services; and (iii) Software is only warranted to perform in accordance with applicable specifications provided by Seller to Buyer for ninety (90) days from the date of delivery or, when downloaded by a Buyer or end-user, from the date of the initial download. All prices are based upon the exclusive limited warranty stated above, and upon the following disclaimer: **EXEMPTION CLAUSE; DISCLAIMER OF WARRANTY, CONDITIONS,**

Continued on Next Page

Offer of Sale Continued

WARNING: This product can expose you to chemicals including Lead and Lead Compounds, and Di(2-ethylhexyl)phthalate (DEHP) which are known to the State of California to cause cancer and birth defects or other reproductive harm. For more information go to www.P65Warnings.ca.gov

REPRESENTATIONS: THIS WARRANTY IS THE SOLE AND ENTIRE WARRANTY, CONDITION, AND REPRESENTATION, PERTAINING TO PRODUCTS. SELLER DISCLAIMS ALL OTHER WARRANTIES, CONDITIONS, AND REPRESENTATIONS, WHETHER STATUTORY, EXPRESS OR IMPLIED, INCLUDING BUT NOT LIMITED TO THOSE RELATING TO DESIGN, NONINFRINGEMENT, MERCHANTABILITY, AND FITNESS FOR A PARTICULAR PURPOSE. SELLER DOES NOT WARRANT THAT THE SOFTWARE IS ERROR-FREE OR FAULT-TOLERANT, OR THAT BUYER'S USE THEREOF WILL BE SECURE OR UNINTERRUPTED, UNLESS OTHERWISE AUTHORIZED IN WRITING BY SELLER. THE SOFTWARE SHALL NOT BE USED IN CONNECTION WITH HAZARDOUS OR HIGH-RISK ACTIVITIES OR ENVIRONMENTS. EXCEPT AS EXPRESSLY STATED HEREIN, ALL PRODUCTS ARE PROVIDED "AS IS".

6. Claims; Commencement of Actions. Buyer shall promptly inspect all Products upon receipt. No claims for shortages will be allowed unless reported to Seller within ten (10) days of delivery. Buyer shall notify Seller of any alleged breach of warranty within thirty (30) days after the date the non-conformance is or should have been discovered by Buyer. Any claim or action against Seller based upon breach of contract or any other theory, including tort, negligence, or otherwise must be commenced within twelve (12) months from the date of the alleged breach or other alleged event, without regard to the date of discovery.

7. LIMITATION OF LIABILITY, IN THE EVENT OF A BREACH OF WARRANTY, SELLER WILL, AT ITS OPTION, REPAIR OR REPLACE THE NON-CONFORMING PRODUCTS, REPERFORM THE SERVICES, OR REFUND THE PURCHASE PRICE PAID WITHIN A REASONABLE PERIOD OF TIME. IN NO EVENT IS SELLER LIABLE FOR ANY SPECIAL, INDIRECT, INCIDENTAL OR CONSEQUENTIAL DAMAGES INCLUDING ANY LOSS OF REVENUE OR PROFITS, WHETHER BASED IN CONTRACT, TORT OR OTHER LEGAL THEORY. IN NO EVENT SHALL SELLER'S LIABILITY UNDER ANY CLAIM MADE BY BUYER EXCEED THE PURCHASE PRICE PAID FOR THE PRODUCTS.

8. Confidential Information. Buyer acknowledges and agrees that Confidential Information has been and will be received in confidence and will remain the property of Seller. Buyer further agrees that it will not use Seller's Confidential Information for any purpose other than for the benefit of Seller and shall return all such Confidential Information to Seller within thirty (30) days upon request.

9. Loss to Buyer's Property. Buyer's Property will be considered obsolete and may be destroyed by Seller after two (2) consecutive years have elapsed without Buyer ordering the Products manufactured using Buyer's Property. Also, Seller shall not be responsible for any loss or damage to Buyer's Property while it is in Seller's possession or control.

10. Special Tooling. Seller may impose a tooling charge for any Special Tooling. Special Tooling shall be and remain Seller's property. In no event will Buyer acquire any interest in the Special Tooling, even if such Special Tooling has been specially converted or adapted for manufacture of Goods for Buyer and notwithstanding any charges paid by Buyer. Unless otherwise agreed, Seller has the right to alter, discard or otherwise dispose of any Special Tooling or other property owned by Seller in its sole determination at any time.

11. Security Interest. To secure payment of all sums due from Buyer, Seller retains a security interest in all Products delivered to Buyer and, Buyer's acceptance of these Terms is deemed to be a Security Agreement under the Uniform Commercial Code. Buyer authorizes Seller as its attorney to execute and file on Buyer's behalf all documents Seller deems necessary to perfect Seller's security interest.

12. User Responsibility. Buyer, through its own analysis and testing, is solely responsible for making the final selection of the Products and assuring that all performance, endurance, maintenance, safety and warning requirements of the application

of the Products are met. Buyer must analyze all aspects of the application and follow applicable industry standards, specifications, and any technical information provided with the Quote or the Products, such as Seller's instructions, guides and specifications. If Seller provides options of or for Products based upon data or specifications provided by Buyer, Buyer is responsible for determining that such data and specifications are suitable and sufficient for all applications and reasonably foreseeable uses of the Products. In the event Buyer is not the end-user of the Products, Buyer will ensure such end-user complies with this paragraph.

13. Use of Products, Indemnity by Buyer. Buyer shall comply with all instructions, guides and specifications provided by Seller with the Quote or the Products. If Buyer uses or resells the Products in any way prohibited by Seller's instructions, guides or specifications, or Buyer otherwise fails to comply with Seller's instructions, guides and specifications, Buyer acknowledges that any such use, resale, or non-compliance is at Buyer's sole risk. Further, Buyer shall indemnify, defend, and hold Seller harmless from any losses, claims, liabilities, damages, lawsuits, judgments and costs (including attorney fees and defense costs), whether for personal injury, property damage, intellectual property infringement or any other claim, arising out of or in connection with: (a) improper selection, design, specification, application, or any misuse of Products; (b) any act or omission, negligent or otherwise, of Buyer; (c) Seller's use of Buyer's Property; (d) damage to the Products from an external cause, repair or attempted repair by anyone other than Seller, failure to follow instructions, guides and specifications provided by Seller, use with goods not provided by Seller, or opening, modifying, deconstructing, tampering with or repackaging the Products; or (e) Buyer's failure to comply with these Terms, including any legal or administrative proceedings, collection efforts, or other actions arising from or relating to such failure to comply. Seller shall not indemnify Buyer under any circumstance except as otherwise provided in these Terms.

14. Cancellations and Changes. Buyer may not cancel or modify, including but not limited to movement of delivery dates for the Products, any order for any reason except with Seller's written consent and upon terms that will indemnify, defend and hold Seller harmless against all direct, incidental and consequential loss or damage and any additional expense. Seller, at any time, may change features, specifications, designs and availability of Products.

15. Assignment. Buyer may not assign its rights or obligations without the prior written consent of Seller.

16. Force Majeure. Seller is not liable for delay or failure to perform any of its obligations by reason of any events or circumstances beyond its reasonable control. Such circumstances include without limitation: accidents, labor disputes or stoppages, government acts or orders, acts of nature, pandemics, epidemics, other widespread illness, or public health emergency, cyber related disruptions, cyber-attacks, ransomware sabotage, delays or failures in delivery from carriers or suppliers, shortages of materials, sudden increases in the price of raw material or components, shutdowns or slowdowns affecting the supply of raw materials or components, or the transportation thereof, oil shortages or oil price increases, energy crisis, energy or fuel interruption, war (whether declared or not) or the serious threat of same, riots, rebellions, acts of terrorism, embargoes, fire or any reason whether similar to the foregoing or otherwise. Seller will resume performance as soon as practicable after the event of force majeure has been removed. All delivery dates affected by an event of force majeure shall be tolled for the duration of such event of force majeure and rescheduled for mutually agreed dates as soon as practicable after the event of force majeure ceases to exist. The right to allocate capacity is in the Seller's sole discretion. An event of force majeure shall not include financial distress, insolvency, bankruptcy, or other

Continued on Next Page

Offer of Sale Continued



WARNING: This product can expose you to chemicals including Lead and Lead Compounds, and Di(2-ethylhexyl)phthalate (DEHP) which are known to the State of California to cause cancer and birth defects or other reproductive harm. For more information go to www.P65Warnings.ca.gov

similar conditions affecting one of the parties, affiliates and/or subcontractors. An event of force majeure in the meaning of these Terms means any circumstances beyond Seller's control that permanently or temporarily hinders performance, even where that circumstance was already foreseen. Buyer shall not be entitled to cancel any orders following its claim of an event of force majeure.

17. Waiver and Severability. Failure to enforce any provision of these Terms will not invalidate that provision; nor will any such failure prejudice either party's right to enforce that provision in the future. Invalidation of any provision of these Terms shall not invalidate any other provision herein and, the remaining provisions will remain in full force and effect.

18. Duration. Unless otherwise stated in the Quote, any agreement governed by or arising from these Terms shall: (a) be for an initial duration of one (1) year; and (b) shall automatically renew for successive one-year terms unless terminated by Buyer with at least 180-days written notice to Seller or if Seller terminates the agreement pursuant to Section 19 of these Terms

19. Termination. Seller may, without liability to Buyer, terminate any agreement governed by or arising from these Terms for any reason and at any time by giving Buyer thirty (30) days prior written notice. Seller may immediately terminate, in writing, if Buyer: (a) breaches any provision of these Terms, (b) becomes or is deemed insolvent, (c) appoints or has appointed a trustee, receiver or custodian for all or any part of Buyer's property, (d) files a petition for relief in bankruptcy on its own behalf, or one is filed against Buyer by a third party, (e) makes an assignment for the benefit of creditors; or (f) dissolves its business or liquidates all or a majority of its assets

20. Ownership of Rights. Buyer agrees that (a) Seller (and/or its affiliates) owns or is the valid licensee of Seller's IP and (b) the furnishing of information, related documents or other materials by Seller to Buyer does not grant or transfer any ownership interest or license in or to Seller's IP to Buyer, unless expressly agreed in writing. Without limiting the foregoing, Seller retains ownership of all Software supplied to Buyer. In no event shall Buyer obtain any greater right in and to the Software than a right in a license limited to the use thereof and subject to compliance with any other terms provided with the Software. Buyer further agrees that it will not, directly or through intermediaries, reverse engineer, decompile, or disassemble any Software (including firmware) comprising or contained within a Product, except and only to the extent that such activity may be expressly permitted, either by applicable law or, in the case of open source software, the applicable open source license.

21. Indemnity for Infringement of Intellectual Property Rights. Seller is not liable for infringement of any Intellectual Property Rights except as provided in this Section. Seller will defend at its expense and will pay the cost of any settlement or damages awarded in an action brought against Buyer based on a third-party claim that one or more of the Products infringes the Intellectual Property Rights of a third party in the country of delivery of the Products by Seller to Buyer. Seller's obligation to defend and indemnify Buyer is contingent on Buyer notifying Seller within ten (10) days after Buyer becomes aware of any such claim, and Seller having sole control over the defense of the claim including all negotiations for settlement or compromise. If one or more Products is subject to such a claim, Seller may, at its sole expense and option, procure for Buyer the right to continue using the Products, replace or modify the Products to render them non-infringing, or offer to accept return of the Products and refund the purchase price less a reasonable allowance for depreciation. Seller has no obligation or liability for any claim of infringement: (i) arising from information provided by Buyer (including Seller's use of Buyer's Property); or (ii) directed to any Products for which the designs are specified in whole or part by Buyer; or (iii) resulting from the modification, combination or use in a system of any Products. The foregoing provisions of this Section constitute Seller's sole and exclusive liability and Buyer's sole and exclusive remedy for claims of infringement of Intellectual Property Rights.

22. Governing Law. These Terms, the terms of any Quote, and the sale and delivery of all Products are deemed to have taken place in, and shall be governed and construed in accordance with, the laws of the State of Ohio, as applicable to contracts executed and wholly performed therein and without regard to conflicts of laws principles. Buyer irrevocably agrees and consents to the exclusive jurisdiction and venue of the courts of Cuyahoga County, Ohio with respect to any dispute, controversy or claim arising out of or relating to the sale and delivery of the Products.

23. Entire Agreement. These Terms, along with the terms set forth in the Quote, forms the entire agreement between the Buyer and Seller and constitutes the final, complete and exclusive expression of the terms of sale and purchase. In the event of a conflict between any term set forth in the Quote and these Terms, the terms set forth in the Quote shall prevail. All prior or contemporaneous written or oral agreements or negotiations with respect to the subject matter shall have no effect. No modification to these Terms will be binding on Seller unless agreed to in a writing that is signed by an authorized representative of Seller, excluding email correspondence, 'clickwrap' or other purported electronic assent to different or additional terms. Sections 2-25 of these Terms shall survive termination or cancellation of any agreement governed by or arising from these Terms.

24. No 'Wrap' Agreements/No Authority to Bind. Seller's clicking any buttons or any similar action, such as clicking "I Agree" or "Confirm," to utilize Buyer's software or webpage for the placement of orders, is NOT an agreement to Buyer's Terms and Conditions. **NO EMPLOYEE, AGENT OR REPRESENTATIVE OF SELLER HAS THE AUTHORITY TO BIND SELLER BY THE ACT OF CLICKING ANY BUTTON OR SIMILAR ACTION ON BUYER'S WEBSITE OR PORTAL.**

25. Compliance with Laws. Buyer agrees to comply with all applicable laws, regulations, and industry and professional standards, including those of the United States of America, and the country or countries in which Buyer may operate, including without limitation the U.S. Foreign Corrupt Practices Act ("FCPA"), the U.S. Anti-Kickback Act ("Anti-Kickback Act"), U.S. and E.U. export control and sanctions laws ("Export Laws"), the U.S. Food Drug and Cosmetic Act ("FDCA"), and the rules and regulations promulgated by the U.S. Food and Drug Administration ("FDA"), each as currently amended. Buyer agrees to indemnify, defend, and hold harmless Seller from the consequences of any violation of such laws, regulations and standards by Buyer, its employees or agents. Buyer represents that it is familiar with all applicable provisions of the FCPA, the Anti-Kickback Act, Export Laws, the FDCA and the FDA and certifies that Buyer will adhere to the requirements thereof and not take any action that would make Seller violate such requirements. Buyer represents and agrees that Buyer will not make any payment or give anything of value, directly or indirectly, to any governmental official, foreign political party or official thereof, candidate for foreign political office, or commercial entity or person, for any improper purpose, including the purpose of influencing such person to purchase Products or otherwise benefit the business of Seller. Buyer further represents and agrees that it will not receive, use, service, transfer or ship any Products from Seller in a manner or for a purpose that violates Export Laws or would cause Seller to be in violation of Export Laws. Buyer agrees to promptly and reliably provide Seller all requested information or documents, including end-user statements and other written assurances, concerning Buyer's ongoing compliance with Export Law.

09/22

Offer of Sale



Offer of Sale

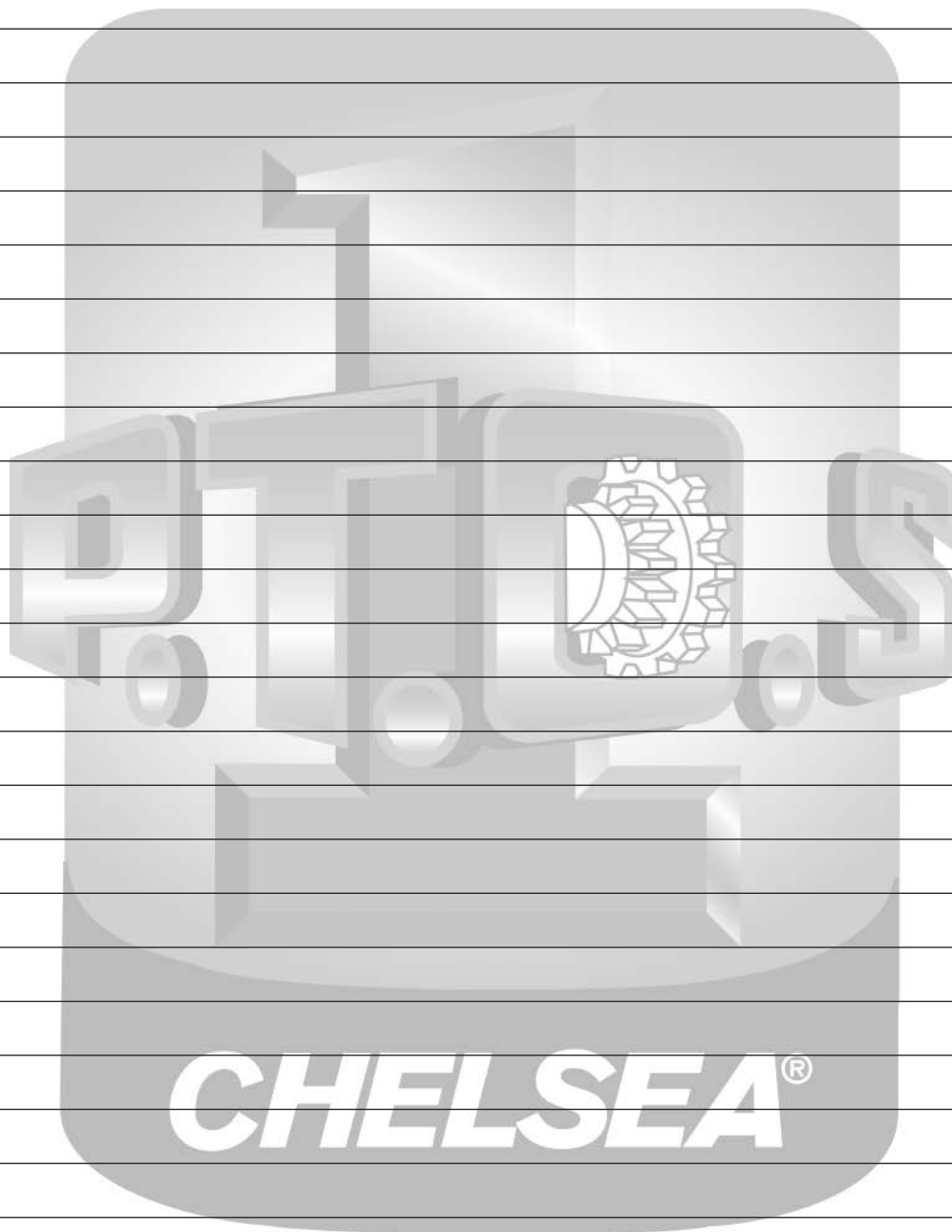

Offer of Sale



Offer of Sale

Chelsea Products

Mechanical Shift 6/8-Bolt

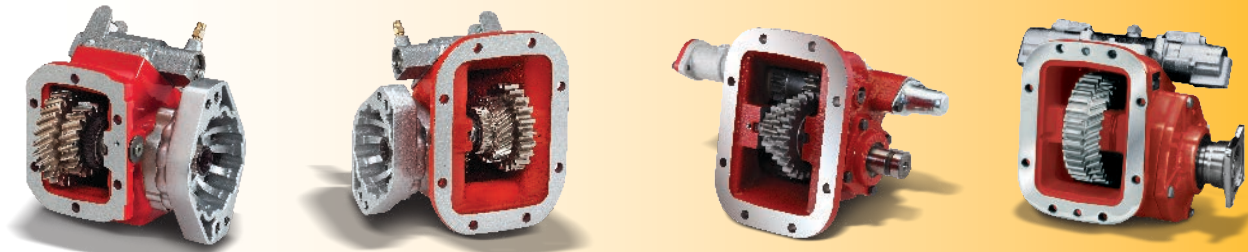

PowerShift 6/8-Bolt

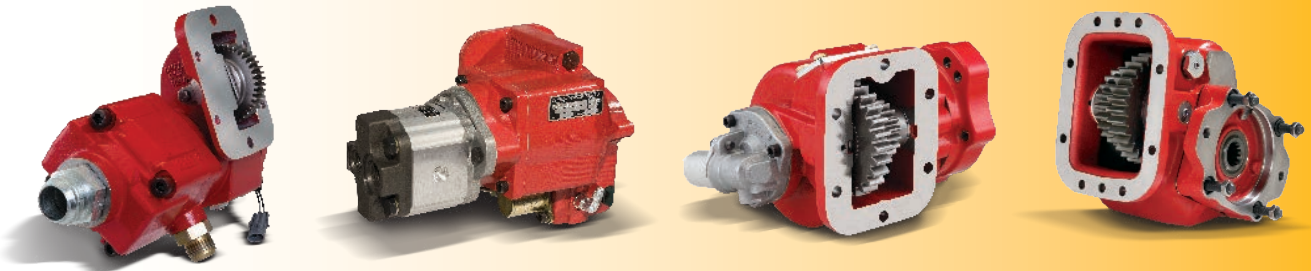

PowerShift 10-Bolt

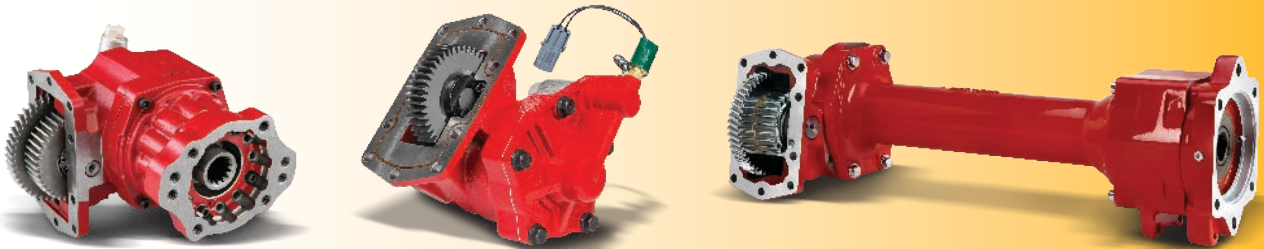

Rear Mount

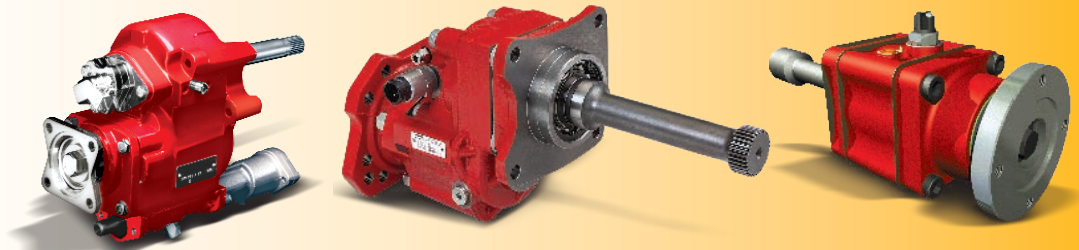

Split Shaft Gear Boxes

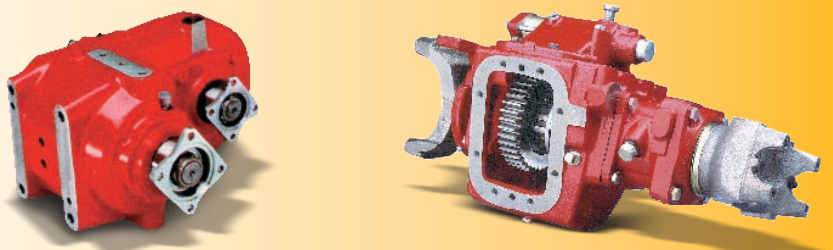

Sales Offices Worldwide

North America

Canada

Parker Hannifin Canada

160 Chisholm Drive
Milton, Ontario L9T 3G9
Tel: (905) 693-3000
Fax: (905) 876-1958

Mexico

Parker Hannifin de México

S.A. de C.V.

Motion and Control Division

Av. Eje Uno Norte 100
Parque Industrial Toluca 2000
Toluca
Edo Mex
Mexico
50233
Tel: 722 275 42 00
contacto@parker.com

Latin America

Pan American Div

7400 N W 19th St Suite A
Miami, FL 33126
UNITED STATES
Tel: (305) 470-8800
Fax: (305) 470-8809

South America

Brazil

Parker Hannifin Industria e

Comercio Ltda.

Hydraulics Division
Av Frederico Ritter 1100
District Industrial
94930-000 Cachoeirinha
RS, Brazil
Tel: 55 51 3470 9144
Fax: 55 51 3470 9281

Europe

Parker Chelsea Products Europe

Parker Hannifin Manufacturing

Germany GmbH & Co. KG

Neefestrasse 96
09116 Chemnitz
GERMANY
Tel: + 49 371 39370
Fax: + 49 371 3937-143

South Asia

Chelsea Products

Parker Hannifin India Pvt. Ltd.

TTC Industrial Area, Mahape
Navi Mumbai - 400 709, India
Tel: +91 22 4124 2500
Fax: +91 22 2768 6841

South Africa

Parker Hannifin Pty Ltd

Sales Company South Africa

10 Berne Avenue
Airport
Kempton Park
SOUTH AFRICA
1620
Tel: +0119610700
Fax: +011392213

Asia Pacific

Australia

Parker Hannifin (Australia)

Pty. Ltd.

9 Carrington Road
Castle Hill
New South Wales, 2154
Tel: 61 2 9842-5150
Fax: 61 2 9842-5111

Parker Hannifin Singapore Pte

No 11 Fourth Chin Bee Rd

Jurong Town

SINGAPORE

619702
Tel: +6568876300

Parker Hannifin Hong Kong Ltd

RM 2001-04 20/F & 2011-12 20/F

THE GATEWAY

HARBOUR CITY TWR 2

TSIM SHA TSUI

KOWLOON

HONG KONG

Tel: +024288008

Fax: +024804256

Parker Hannifin Motion & Control (Shanghai) Co., Ltd.

280 Yunqiao Road, Jinqiao Export

Processing Zone

Shanghai 201206, P. R. China

Tel: +02128995000

Fax: +02158348975

Parker Hannifin Beijing

Suite B9-B11

21/F Hanwei Plaza

No. 7 Guanghua Road

Chaoyang District

Beijing 100004, China

Tel: (+86) 10 6561 0520 - 5

Fax: (+86) 10 6561 0526 - 7

